



UFI FILTERS

Filtri Oleodinamici

Filtri Aria



 HYDRAULIC
COMPONENTS
& FLUID CONTAMINATION
CONTROL



CBA
AIR FILTERS



DESCRIPTION

Air breather, hand mounting

MATERIALS

Housing, flange and basket: Zinc plated steel
Cap: Chrome plated

Filter element (not replaceable, filtration degree in air):
Impregnated cellulose 3µm
Polyurethane foam 10µm

FLOW RATE

Qmax 750 l/min

COMPATIBLY

Full with fluids HH-HL-HM-HV-HTG (according to ISO 6743/4).
For fluids different than the above mentioned, please contact
our Customer Service.

WORKING TEMPERATURE:

From -25°C to 110°C



HYDRAULIC DIAGRAM

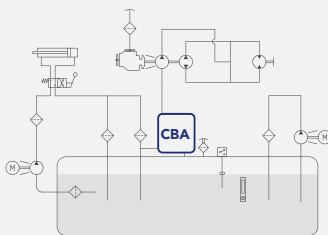

Is this datasheet the latest release? Please check on our website

ORDERING AND OPTION CHART

C	B	A	COMPLETE FILTER FAMILY	
			SIZE & LENGHT	
			11	21
			PORT TYPE	
			B = BSP thread	B B
			PORT SIZE	
			02 = 1/4"	02 -
			06 = 3/4"	- 06
			FILTER MEDIA	
			CC = impregnated cellulose 3 µm	CC CC
			PE = polyurethane foam 10 µm	PE PE

INSTALLATION DRAWING

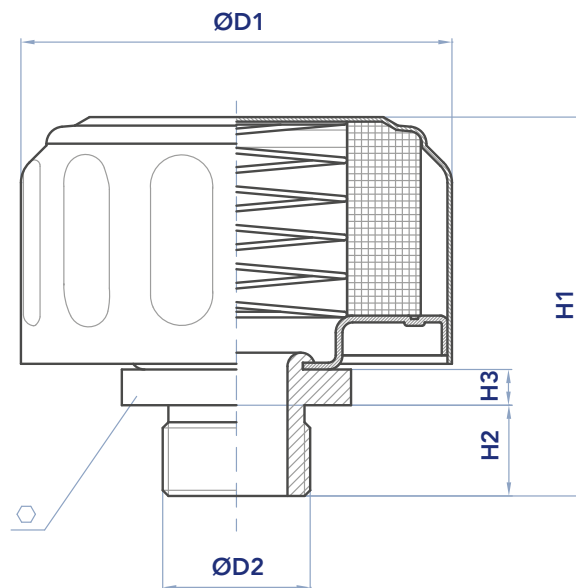

DIMENSIONS

	filtr. µm (in air)	flow rate (l/min)	D1	D2	H1	H2	H3	
CBA11B02CC	3	150	47	1/4" BSP	19	45	12	7
CBA11B02PE	10	250	47	1/4" BSP	19	45	12	7
CBA21B06CC	3	450	76	3/4" BSP	35	66	16	7
CBA21B06PE	10	750	76	3/4" BSP	35	66	16	7



CBB

AIR FILTERS



DESCRIPTION

Air breather with threaded connection

MATERIALS

Housing and threaded connection: Zinc plated steel
Spare filter element: Impregnated cellulose 10 μm
(filtration degree in air)

FLOW RATE

Qmax 500 l/min

COMPATIBLY

Full with fluids HH-HL-HM-HV-HTG (according to ISO 6743/4).
For fluids different than the above mentioned, please contact
our Customer Service.

WORKING TEMPERATURE

From -25°C to 110°C



HYDRAULIC DIAGRAM

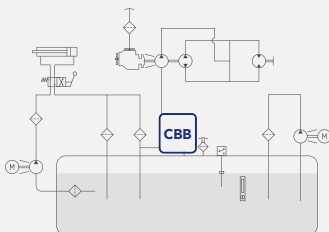

Is this datasheet the latest release? Please check on our website

ORDERING AND OPTION CHART

C	B	B	COMPLETE FILTER FAMILY				FILTER ELEMENT FAMILY	E	B	B
			SIZE & LENGHT	11	21	31	SIZE & LENGTH			
			PORT TYPE							
			B = BSP thread	B	B	B				
			M = metric thread	M	M	M				
			PORT SIZE							
			02 = 1/4"	02	-	-				
			03 = 3/8"	03	-	-				
			04 = 1/2"	-	04	-				
			06 = 3/4"	-	06	-				
			08 = 1"	-	-	08				
			12 = M 12x1,5 (metric only)	12	-	-				
			16 = M 16x1,5 (metric only)	-	16	-				
			FILTER MEDIA				FILTER MEDIA			
			CD = impregnated cellulose 10µm	CD	CD	CD				

INSTALLATION DRAWING

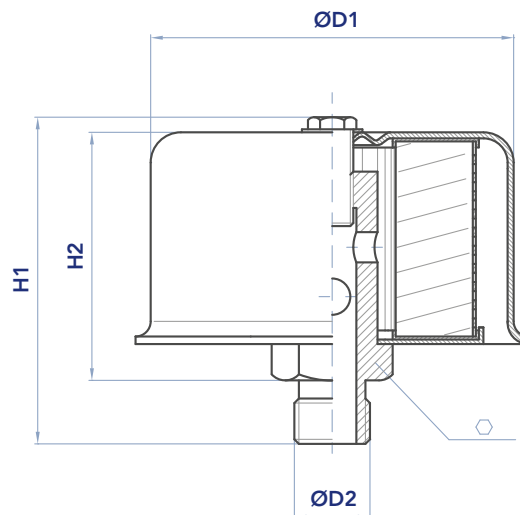

DIMENSIONS

	filtr. µm	flow rate (l/min)	D1	D2	⬡	H1	H2	KG
CBB11B02CD	10	200	60	1/4" BSP	22	56	43	0,16
CBB11B03CD	10	200	60	3/8" BSP	22	56	43	0,16
CBB11M12CD	10	200	60	M12 X 1,5	17	56	43	0,16
CBB21B04CD	10	500	82	1/2" BSP	24	71	53	0,30
CBB21B06CD	10	500	82	3/4" BSP	32	71	53	0,30
CBB21M16CD	10	500	82	M16 X 1,5	22	71	53	0,30
CBB31B08CD	10	850	115	1" BSP	40	100	76	0,50



CBC AIR FILTERS

DESCRIPTION

Air breather filter, extension tube available on request

MATERIALS

Housing: Plastic
Basket: Plastic
Seal: NBR Nitrile
Spare filter element: Impregnated Cellulose 3µm
(Filtration degree in air)

FLOW RATE

Qmax 1800 l/min

COMPATIBLY

Full with fluids HH-HL-HM-HV-HTG (according to ISO 6743/4).
For fluids different than the above mentioned, please contact
our Customer Service.

WORKING TEMPERATURE

From -25°C to 110°C



HYDRAULIC DIAGRAM

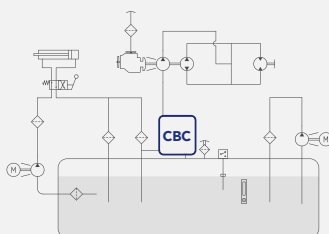

Is this datasheet the latest release? Please check on our website

ORDERING AND OPTION CHART

C	B	C	COMPLETE FILTER FAMILY		FILTER ELEMENT FAMILY	E	B	C
2	1		SIZE & LENGHT	21	SIZE & LENGTH	2	1	
			CONNECTION TYPE					
			S = flange	S				
			PORT SIZE					
			00 = DIN 24557/2	00				
W			PRESSURIZATION VALVE					
			W = without	W				
N			SEALS		SEALS		N	
			N = NBR Nitrile	N				
C	C		FILTER MEDIA		FILTER MEDIA	C	C	
			CC = impregnated cellulose 3 µm	CC				
W			ACCESSORIES					
			W = without	W				

INSTALLATION DRAWING

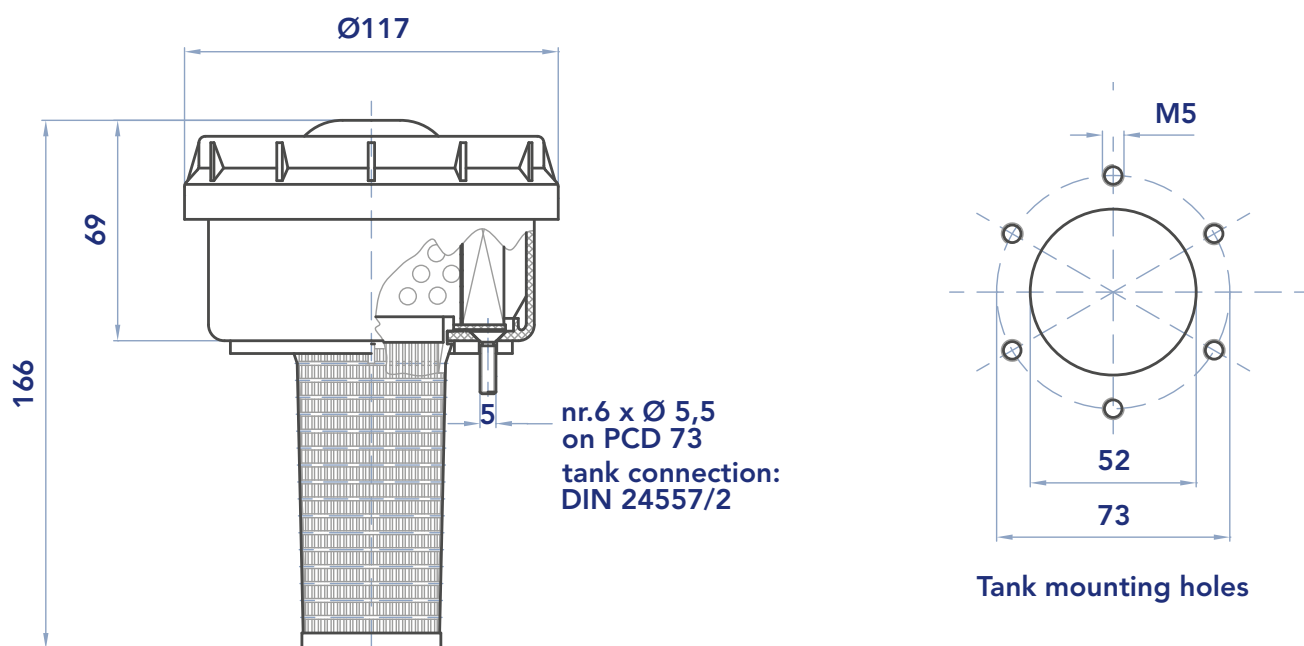



CBD

AIR FILTERS



DESCRIPTION

Air breather, thread mounted

MATERIALS

Housing: Black painted steel

Spare filter element: Filtration degree in air

VD - Velvet mesh 10 μm

FD - Fibreglass 2,5 μm (on request only)

CD - Impregnated cellulose 10 μm (on request only)

FLOW RATE

Qmax 1500 l/min

COMPATIBLY

Full with fluids HH-HL-HM-HV-HTG (according to ISO 6743/4).

For fluids different than the above mentioned, please contact our Customer Service.

WORKING TEMPERATURE

From -25°C to 110°C



HYDRAULIC DIAGRAM

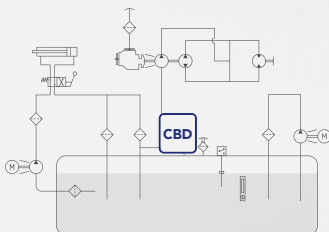

Is this datasheet the latest release? Please check on our website

ORDERING AND OPTION CHART

C	B	D	COMPLETE FILTER FAMILY				FILTER ELEMENT FAMILY	E	B	D
			SIZE & LENGHT	11	12	13	SIZE & LENGTH			
	B		PORT TYPE							
			B = BSP thread	B	B	B				
1	6		PORT SIZE							
			16 = 2"	16	16	16				
			FILTER MEDIA				FILTER MEDIA			
			VD = velvet mesh 10 µm	VD	VD	VD				
			FD* = fibreglass 2,5 µm	FD	FD	FD				
			CD* = impregnated cellulose 10 µm	CD	CD	CD				

* on request only

INSTALLATION DRAWING

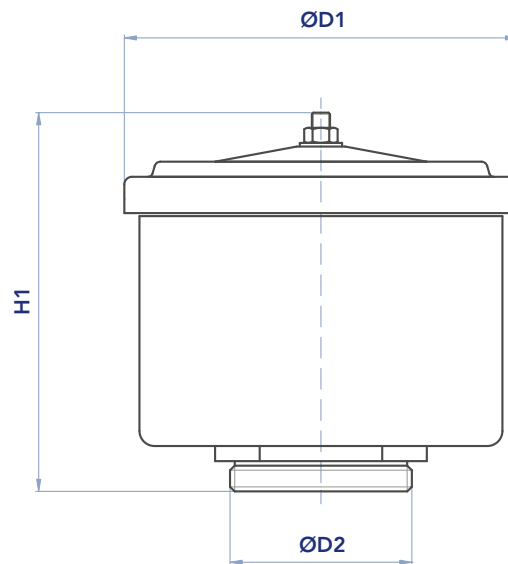

DIMENSIONS

	flow rate (l/min)	D1	D2	H1	KG
CBD11B16VD	500	130	2" BSP	100	0,50
CBD12B16VD	1.000	130	2" BSP	130	0,60
CBD13B16VD	1.500	130	2" BSP	175	0,80



CBE

AIR FILTERS



DESCRIPTION

Air breather, flange mounting

MATERIALS

Housing: Black painted steel

Spare filter element: Filtration degree in air

VD - Velvet mesh 10 μm

FD - Fibreglass 2,5 μm (on request only)

CD - Impregnated cellulose 10 μm (on request only)

FLOW RATE

Qmax 20000 l/min

COMPATIBLY

Full with fluids HH-HL-HM-HV-HTG (according to ISO 6743/4).

For fluids different than the above mentioned, please contact our Customer Service.

WORKING TEMPERATURE

From -25°C to 110°C

HYDRAULIC DIAGRAM

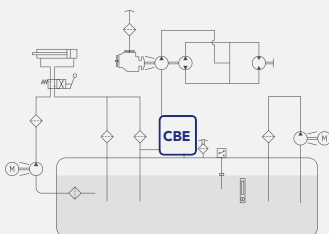

Is this datasheet the latest release? Please check on our website

ORDERING AND OPTION CHART

C	B	E	COMPLETE FILTER FAMILY						FILTER ELEMENT FAMILY	E	B	E
			SIZE & LENGHT	11	12	21	22	23	SIZE & LENGTH			
		F	PORT TYPE									
			F = round flange	F	F	F	F	F				
			PORT SIZE									
			10 = hole ø 100 mm	10	-	-	-	-				
			12 = hole ø 125 mm	-	12	-	-	-				
			14 = hole ø 145 mm	-	-	14	-	-				
			16 = hole ø 165 mm	-	-	-	16	16				
			FILTER MEDIA						FILTER MEDIA			
			VD = velvet mesh 10 µm	VD	VD	VD	VD	VD				
			FD* = fibreglass 2,5 µm	FD	FD	FD	FD	FD				
			CD* = impregnated cellulose 10 µm	CD	CD	CD	CD	CD				

* on request only

INSTALLATION DRAWING

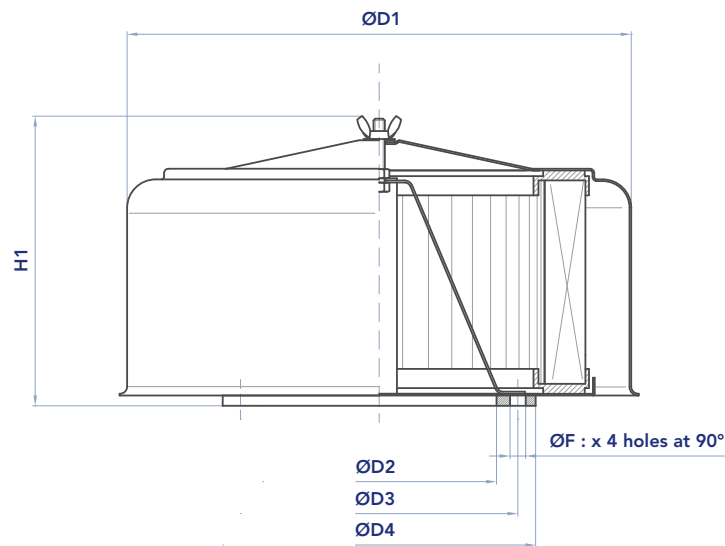

DIMENSIONS

	flow rate (l/min)	D1	D2	D3	D4	F	H1	Kg
CBE11F10VD	6.000	292	100	130	160	8,5	120	2,50
CBE12F12VD	9.000	292	125	155,5	180	11	145	2,80
CBE21F14VD	12.000	354	145	175	200	11	160	2,50
CBE22F16VD	15.000	354	165	195	220	11	190	3,00
CBE23F16VD	20.000	354	165	195	220	11	240	3,50



CBF

AIR FILTERS



DESCRIPTION

Air breather, clamp mounting

MATERIALS

Housing: Black painted steel

Clamp: Stainless steel

Spare filter element: Filtration degree in air

VD - Velvet mesh 10 μm

FD - Fibreglass 2,5 μm (on request only)

CD - Impregnated cellulose 10 μm (on request only)

FLOW RATE

Qmax 4000 l/min

COMPATIBLY

Full with fluids HH-HL-HM-HV-HTG (according to ISO 6743/4).

For fluids different than the above mentioned, please contact our Customer Service.

WORKING TEMPERATURE

From -25°C to 110°C



HYDRAULIC DIAGRAM

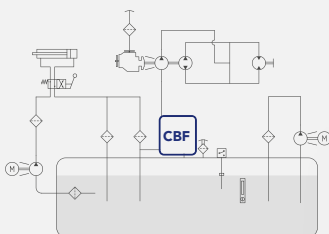

Is this datasheet the latest release? Please check on our website



ORDERING AND OPTION CHART

C	B	F	COMPLETE FILTER FAMILY			FILTER ELEMENT FAMILY	E	B	F
			SIZE & LENGHT	11	21	SIZE & LENGTH			
		C	PORT TYPE						
			C = clamp	C	C				
			PORT SIZE						
			40 = hole ø 40 mm	40	-				
			52 = hole ø 52 mm	52	-				
			70 = hole ø 70 mm	-	70				
			76 = hole ø 76 mm	-	76				
			FILTER MEDIA			FILTER MEDIA			
			VD = velvet mesh 10 µm	VD	VD				
			FD* = fibreglass 2,5 µm	FD	FD				
			CD* = impregnated cellulose 10 µm	CD	CD				

* on request only

INSTALLATION DRAWING

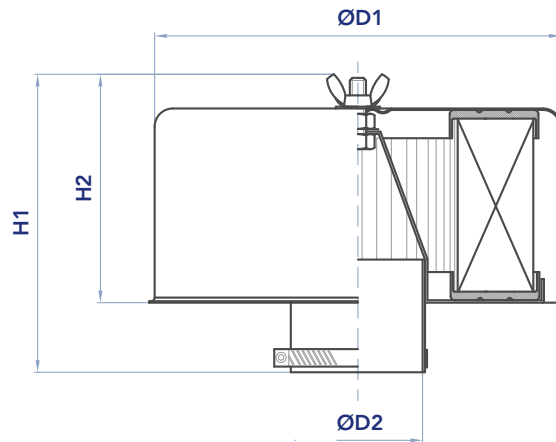

DIMENSIONS

	flow rate (l/min)	D1	D2	H1	H2	Kg
CBF11C40VD	1.000	122	40	120	92	0,60
CBF11C52VD	1.500	122	52	120	92	0,60
CBF21C70VD	3.000	220	70	145	125	1,60
CBF21C76VD	4.000	220	76	145	125	1,60



CBS AIR FILTERS

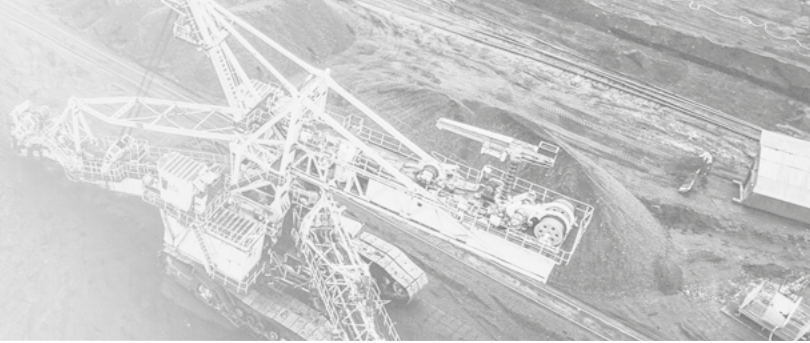

DESCRIPTION

Air breather with spin-on element

MATERIALS

Connector: Steel (zinc plated for the flanged version)

Spin-on can: Steel

Spare filter element:

CC = Impregnated Cellulose

FD = Fibreglass

Filtration degree in air 3 μm

FLOW RATE

Qmax 2800 l/min

COMPATIBILITY

Full with fluids HH - HL - HM - HR - HV - HG (according to ISO 6743/4). For fluids different than the above mentioned, please contact our Customer Service.

WORKING TEMPERATURE

From -25°C to 110°C



HYDRAULIC DIAGRAM

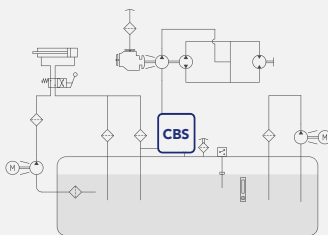

Is this datasheet the latest release? Please check on our website

ORDERING AND OPTION CHART

C	B	S	COMPLETE FILTER FAMILY					FILTER ELEMENT FAMILY	A	S	E
			SIZE & LENGHT	11	12	21	22	SIZE & LENGTH			
			CONNECTION TYPE								
			S = standard flange	S	S	S	S				
			W = welding connector	W	W	W	W				
		W	PRESSURIZATION VALVE								
			W = without	W	W	W	W				
			SEALS					SEALS	X		
			X = no seals (welding type)	X	X	X	X				
			C = sugheroil (flange type)	C	C	C	C				
			FILTER MEDIA					FILTER MEDIA			
			FD = fibreglass	FD	FD	FD	FD				
			CC = impregnated cellulose	CC	CC	CC	CC				

INSTALLATION DRAWING

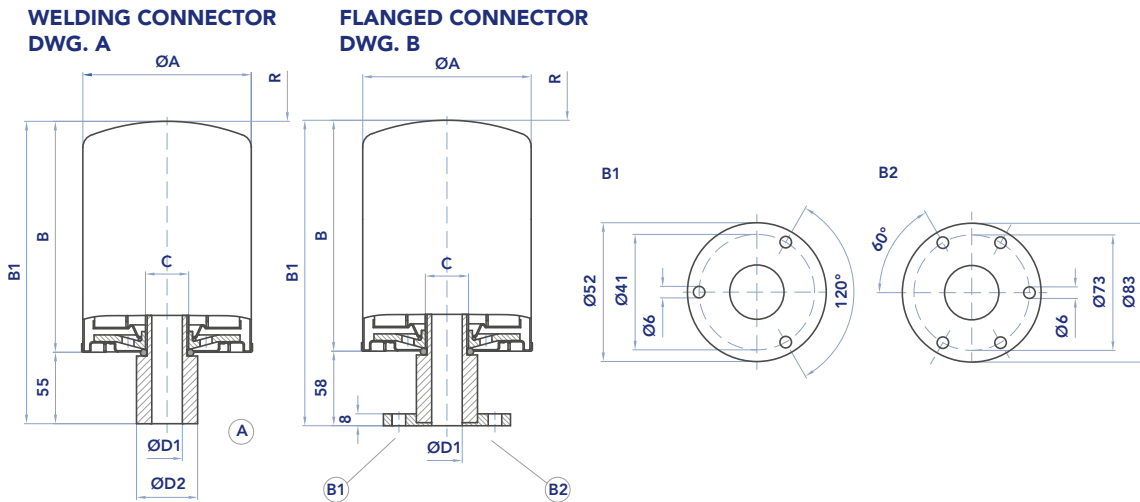

DIMENSIONS

	Dwg	flow rate (l/min)	A	B	B1	C	D1	D2	R
CBS11WWX	A	1.800	96	146	201	3/4" BSP	18	32	40
CBS12WWX	A	1.800	96	191	246	3/4" BSP	18	32	40
CBS21WWX	A	2.800	129	181	236	1 1/4" BSP	32	48	40
CBS22WWX	A	2.800	129	226	281	1 1/4" BSP	32	48	40
CBS11SWC	B1	1.800	96	146	204	3/4" BSP	18	-	40
CBS12SWC	B1	1.800	96	191	249	3/4" BSP	18	-	40
CBS21SWC	B2	2.800	129	181	239	1 1/4" BSP	32	-	40
CBS22SWC	B2	2.800	129	226	284	1 1/4" BSP	32	-	40



CSE AIR FILTERS



DESCRIPTION

Air breather with spin-on element

MATERIALS

Connector: Zinc plated steel
Basket: Zinc plated steel
Spin-on can: Steel
Spare filter element:
CC = Impregnated Cellulose
FD = Fibreglass
Filtration degree in air 3 µm

FLOW RATE

Qmax 2800 l/min

COMPATIBLY

Full with fluids HH - HL - HM - HR - HV - HG (according to ISO 6743/4). For fluids different than the above mentioned, please contact our Customer Service.

WORKING TEMPERATURE

From -25°C to 110°C



HYDRAULIC DIAGRAM

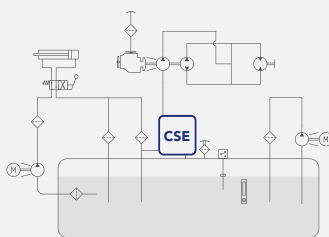

Is this datasheet the latest release? Please check on our website.

ORDERING AND OPTION CHART

C	S	E	COMPLETE FILTER FAMILY					FILTER ELEMENT FAMILY	A	S	E
			SIZE & LENGHT	11	12	21	22	SIZE & LENGTH			
			CONNECTION TYPE								
			S = standard flange	S	S	S	S				
			W PRESSURIZATION VALVE								
			W = without	W	W	W	W				
			SEALS					SEALS		X	
			C = sugheroil (flange type)	C	C	C	C				
			FILTER MEDIA					FILTER MEDIA			
			FD = fibreglass	FD	FD	FD	FD				
			CC = impregnated cellulose	CC	CC	CC	CC				

INSTALLATION DRAWING

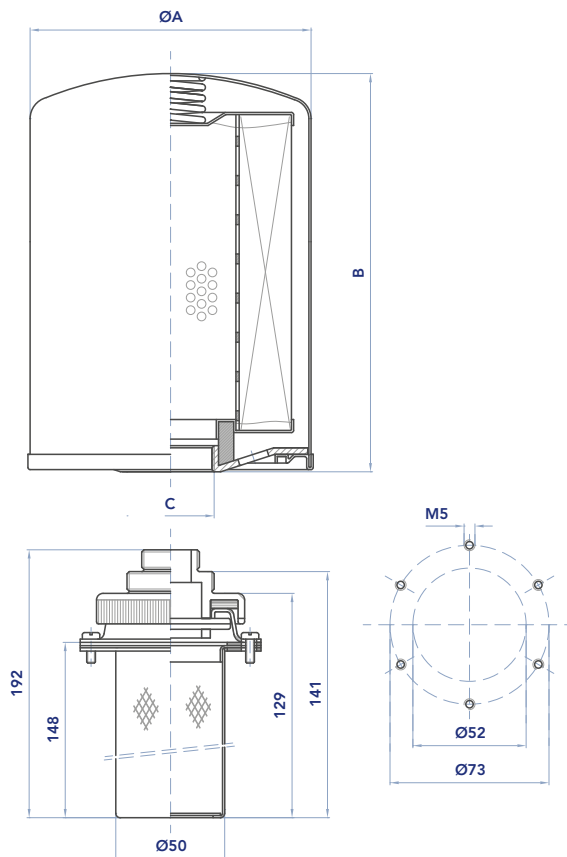

DIMENSIONS

	flow rate (l/min)	A	B	C
CSE11SWC	1.800	96	146	3/4" BSP
CSE12SWC	1.800	96	191	3/4" BSP
CSE21SWC	2.800	129	181	1 1/4" BSP
CSE22SWC	2.800	129	226	1 1/4" BSP



AIR SENTRY

AIR FILTERS

DESCRIPTION

Air dryer filter breather

MATERIALS

D-10+ are manufactured from rugged ABS plastic and impact-modified Plexiglas.

R-10+ have a rugged steel reinforced base for heavy duty applications.

TECHNICAL DATA

Nominal air flow rate: 1.000 l/min

Solid contaminant filtration: 2 μ m

Silica gel adsorption: up to 40% of its weight in water

WORKING TEMPERATURE

From -30°C to 100°C

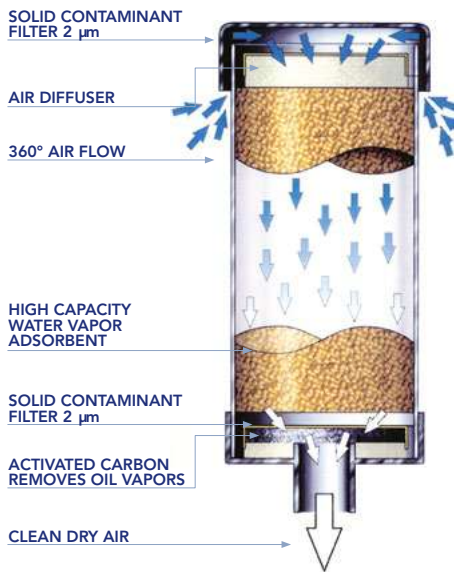

HYDRAULIC DIAGRAM

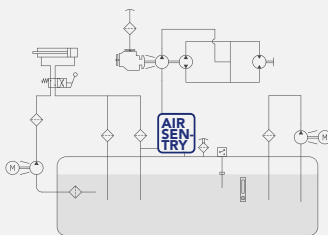

Is this datasheet the latest release? Please check on our website.



AIR SENTRY

AIR FILTERS



CONNECTION TO THE RESERVOIR

The breathers D10+ can be attached to the reservoir by using an adapter:

- mod. A-102 for mounting in a threaded hole 1"
- mod. A-104 for bayonet mounting on a standard flange pattern (6 holes on 73 mm PCD)

The breathers R10+ are attached to the reservoir by 1" NPT male pipe thread.

Adapter A-102
threaded 1" NPT

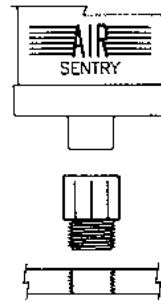

Adapter A-104
bayonet for
standard flange

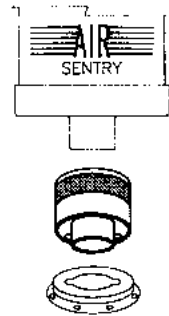

INSTALLATION DRAWING

Air Sentry Breathers use a three-stage filtration design to ensure optimum protection by removing water vapor and solid contaminants before they enter the fluid system.

First, air passes through a fine, 2 µm solid particle filter. The air then passes through a diffuser to ensure maximum effectiveness within the silica gel chamber.

Next, water vapor is removed as the air travels through a bed of silica gel, the highest capacity adsorbent available. After being dried, the air passes through a second 2 µm solid particle filter and enter the reservoir, clean and dry.

Air entering is cleaned and dried. Expelled air partially regenerates the silica gel and backflushes the particulate filter to prolong the life of the breather.

Silica gel is chemically inert, non-toxic, non-deliquescent and non-corrosive. The internal structure is composed of interconnected microscopic pores that adsorb up to 40% of its weight.

When maximum adsorption is reached, the silica gel turns from yellow to blue to indicate that replacement of the breather is required.

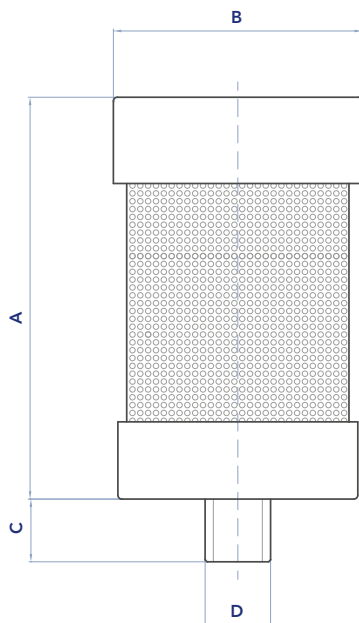

DIMENSIONS

	A	B	C	D	Kg	Max H ₂ O (l)
D-101	127	127	32	to fit an adaptor A-10+	1,0	0,2
D-102	205	127	32	to fit an adaptor A-10+	1,7	0,5
R-101	140	132	25	1"NPT	1,5	0,2
R-102	216	132	25	1"NPT	2,1	0,5

LubeTeam Hydraulic S.r.l.

Administration and Headquarter:

Via Tufara Scautieri, 6

83018 - San Martino Valle Caudina (AV)

Office and Warehouse:

S.S. 7 Appia, Km. 237,00

82011 - Airola BN

ITALY

Tel. +39 0823 950 994

Fax +39 0823 412 546

www.lubeteam.it info@lubeteam.it

Italian VAT / C.F. e P.IVA: 01251720627

Follow us



This document is the property of LubeTeam Hydraulic S.r.l. All data reported here are for the exclusive use of the Receiver. Reproduction is not authorized without writing permission, in all or in part of the content of this document, in accordance to Law 633 art. 171, dated April 22, 1941.

Il presente documento è di proprietà della LubeTeam Hydraulic S.r.l. I dati riportati sono per esclusivo del destinatario. La riproduzione, di tutto o in parte, non è autorizzata senza permesso scritto secondo l'art. 171 della L. 633 del 22 Aprile 1941.