

Speed Reducers
Riduttori di Velocità



 HYDRAULIC
COMPONENTS
& FLUID CONTAMINATION
CONTROL



All trademarks belong to their respective owners; third party trademarks, product names, trade names, corporate names and company names mentioned may be trademarks of their respective owners or registered trademarks of other companies and are used for instructional purposes and for the benefit of the owner, without any end of Copyright infringement in force.

Tutti i marchi riportati appartengono ai legittimi proprietari; marchi di terzi, nomi di prodotti, nomi commerciali, nomi corporativi e società citati possono essere di proprietà dei rispettivi titolari o registrati da altre società e sono stati utilizzati a puro scopo esplicativo e a beneficio del possessore, senza alcun fine di violazione dei diritti di Copyright vigenti.



I riduttori vengono impiegati per il collegamento di motori idraulici su macchine agricole semoventi, macchine movimento terra e settore marino. Il regime d'uscita dei riduttori è di 200 g/1' per cui il regime d'esercizio dei motori idraulici viene rapportato adeguatamente, sempre che il regime d'entrata non superi i 3000 g/1'.

SCATOLE: in alluminio e in ghisa ad alta resistenza meccanica.

INGRANAGGI: gli ingranaggi sono stati calcolati in conformità alle norme ISO/DIN 3990-80 e costruiti in acciaio UNI 18N. CrMoS. La dentatura è corretta e sbarbata.

ALBERI: gli alberi sono costruiti in acciaio 16 Cr.Ni4, accoppiati con gli ingranaggi mediante chiavetta.

COPIE: le coppie espresse nelle tabelle tecniche dei singoli riduttori sono quelle per l'esercizio di lavoro continuo. Le coppie che si verificano in condizioni di lavoro intermittente possono essere superate del 20%.

LUBRIFICAZIONE: Un corretto uso di olio SAE90, permette un buon funzionamento e durata del gruppo. Il livello dell'olio deve essere controllato a vista mediante l'apporto spia ogni 2000 ore. La sostituzione del primo cambio d'olio deve essere fatta dopo 100 ÷ 150 ore di funzionamento.

TEMPERATURA D'ESERCIZIO: La temperatura d'esercizio continua non deve superare i 120°C.

MONTAGGIO MOTORE IDRAULICO: Il montaggio dei motori idraulici ai riduttori è specifico perchè l'utilizzatore può acquistare motori con l'albero cilindrico per cui necessita chiavetta oppure scanalato secondo norme DIN o norme SAE e il collegamento è diretto.

L'applicazione di organi speciali sui ns. riduttori e che richiedono caratteristiche di funzionamento diverse da quanto espresso nel presente catalogo, chiedere informazioni al ns. ufficio tecnico.

Les réducteurs sont employés pour l'accouplement de moteurs hydrauliques sur des machines agricoles automotrices, sur des machines de terrassement et dans le secteur marin. Le régime de sortie des réducteurs est de 200 trs/mn; par conséquent, le régime d'exercice des moteurs hydrauliques doit avoir un rapport adéquat, à condition que le régime d'entrée ne dépasse pas 3000 trs/mn.

BOÏTIERS: en aluminium et en fonte à très grande résistance mécanique.

ENGRENAGES: Les engrenages ont été calculés en conformité avec les normes ISO/DIN 3990-80 et ils ont été fabriqués en acier UNI 18NiCrMo5. La denture est correcte et ébarbée.

ARBRES: Les arbres sont fabriqués en acier 16CrNi4, accouplés avec les engrenages au moyen de clavettes.

COUPLES: Les couples indiqués dans les tableaux techniques de chaque réducteur sont les couples d'exercice de travail continu. Les couples qui se produisent en conditions de travail intermittent peuvent les dépasser de 20%.

LUBRIFICATION: Un emploi correct d'huile SAE 90 permet un bon fonctionnement et une longue durée du groupe. Le niveau de l'huile doit être contrôlé à l'oeil nu par le témoin spécial toutes les 2000 heures. La première vidange doit être faite après 100-150 heures de fonctionnement.

TEMPÉRATURE D'EXERCICE: La température d'exercice continu ne doit pas dépasser 120°C.

ACCOUPEMENT AUX MOTEURS HYDRAULIQUES: L'assemblage des moteurs hydrauliques aux réducteurs est spécifique parce que l'utilisateur peut acheter des moteurs avec un arbre cylindrique qui nécessite une clavette ou bien avec arbre cannelé aux normes DIN ou aux normes SAE qui est directement accouplé.

L'application d'organes spéciaux sur nos réducteurs nécessite des caractéristiques de fonctionnement différentes de celles qui sont indiquées dans ce catalogue; vous adresser à notre bureau technique pour des informations supplémentaires.

They are used for installing hydraulic motors on to self-propelled farm machinery, earth moving machines and marine machines. Reducer output speed is 200 R.P.M. therefore the working speed of hydraulic motors is to be adjusted accordingly, provided that input speed is not higher than 3000 R.P.M.

GEARBOX: made in aluminium and in iron with high mechanical resistance.

GEARS: in compliance with ISO/DIN 3990-80 standards. Made in steel UNI.... with properly shaved teeth. .

SHAFTS: made in steel... and key-coupled with gears.

TORQUES: Torques mentioned in technical charts of reducers refer to continuous duty. Torques under intermittent duty may be higher by 20%.

LUBRICATION: Oil SAE 90 ensure proper running and long life of the unit. Check oil level via the special oil window every 50 hours.

Change oil first after 100-150 working hours. Working temperature: should not exceed 120°C under continuous duty.

HYDRAULIC MOTOR INSTALLATION: The installation of hydraulic motors on to reducers is a particular operation because the user may purchase motors with cylindrical shaft (thus requiring key) or spline shaft in compliance with DIN or SAE standards (in this case coupling is made directly).

Please contact our technical department if you fit on to our reducers special component parts with working characteristics different from those mentioned in this catalogue.

Die Untersetzungsgetriebe werden für die Kupplung von Hydraulikmotoren auf landwirtschaftlichen Maschinen mit Eigenantrieb, Erdbewegungsmaschinen und im Schiffsbau verwendet. Die Abtriebsdrehzahl der Untersetzungsgetriebe ist 200/min-1 wodurch die Betriebsdrehzahl der Hydraulikmotoren entsprechend ausgelegt werden kann. Einzige Einschränkung ist, daß die Antriebsdrehzahl nicht über 3000/min-1 sein darf.

GEHÄUSE: Aus Alu-Kokillenguß mit Teilen aus Eisen mit hohen Festigkeitswerten. .

ZAHNRÄDER: Die Zahnräder sind nach ISO/DIN 3990-80 Norm berechnet; der Werkstoff ist Stahl UNI 18NiCrMo5; die Verzahnung ist entgratet.

WELLEN: Die Wellen bestehen aus Stahl 16CrNi4, die Kupplung erfolgt mit Keilen.

DREHMOMENTE: Die in den Tabellen für die einzelnen Untersetzungsgetriebe angegebenen Drehmomente verstehen sich für Dauerbetrieb. Bei intermittierendem Betrieb können die genannten Werte um 20% überschritten werden.

SCHMIERUNG: Ein korrekter Einsatz von SAE 90 Öl gewährleistet einen einwandfreien Betrieb und eine lange Lebensdauer des Getriebes. Der Ölstand ist durch das Schauglas in Intervallen von 2000 Betriebsstunden zu kontrollieren. Der erste Ölwechsel am neuen Getriebe muß nach ca. 100-150 Betriebsstunden durchgeführt werden.

BETRIEBSTEMPERATUR: Bei Dauerbetrieb darf die max. Betriebstemperatur 120°C nicht übersteigen.

KUPPLUNG AN HYDRAULIKMOTOREN: Die Kupplung an Hydraulikmotoren bedarf größter Sorgfalt, da der Verwend er Motoren mit geradem Wellenende einsetzen kann, wodurch eine Keilverbinding notwendig wird oder aber Motoren mit Keilwellen nach DIN- oder SAE- Normen einsetzt, was direkte Kupplungen voraussetzt.

Bei Verwendung von Sonderbauteilen in Verbindung mit unseren Untersetzungsgetrieben, die andere als die in diesem Katalog aufgeführten Betriebseigenschaften voraussetzen, ist eine Rücksprache mit unserem Konstruktionsbüro von Vorteil.



SERIE 95000

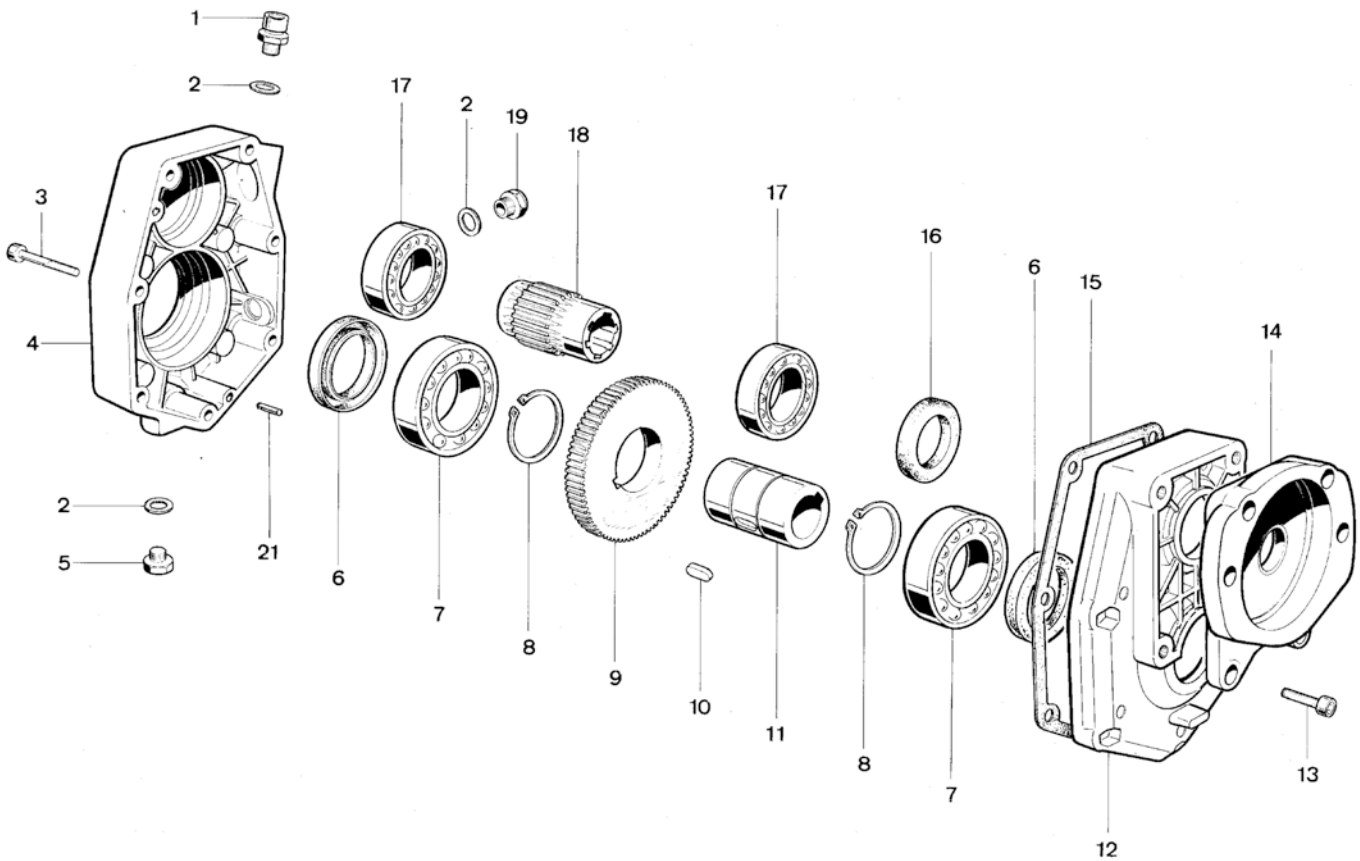

POS.	DENOMINAZIONE	DENOMINATION	DESCRIPTION	BEZEICHNUNG	Q.TÀ
1	Tappo sfiato olio 3/8"	Bouchon reniflard huile 3/8"	Oil breather plug 3/8"	Entlüftungsschraube 3/8"	1
2	Guarnizione	Joint	Gasket	Dichtung	3
3	Vite T.C.E.I. M6x50	Vis T.C.H.C. M6x50	Socket cap screw M6x50	Zylinderkopfschraube mit Innensechskant M6x50	8
4	Scatola	Carcasse	Housing	Gehäuse	1
5	Tappo scarico olio 3/8"	Bouchon vidange huile 3/8"	Oil drain plug 3/8"	Ölablaßschraube 3/8"	1
6	Anello tenuta \varnothing 50x65x8	Bague d'étanchéité D. 50x65x8	Sealing ring 50x65x8	Dichtring, Durchm. 50x65x8	2
7	Cuscinetto tipo 6010	Palier 6010	Bearing type 6010	Kugellager, Typ 6010	2
8	Anello seeger \varnothing 50	Circlip D. 50	Snap ring \varnothing 50	Seegerring, Durchm. 50	2
9	Corona	Couronne	Ring gear	Zahnkranz	1
10	Chiavetta 12x20	Clavette 12x20	Key 12x20	Keil 12x20	1
11	Albero cavo \varnothing 35	Arbre creux D. 35	Hollow shaft \varnothing 35	Hohlwelle, Durchm. 35	1
12	Coperchio	Couvercle	Cover	Deckel	1
13	Vite M8x20	Vis M8x20	Screw M8x20	Schraube M8x20	4
14	Flangia SAE A	Bride SAE A	Flange SAE A	Flansch, SAE A	1
15	Guarnizione	Joint	Gasket	Dichtung	1
16	Anello di tenuta \varnothing 35x52x7	Bague d'étanchéité 35x52x7	Sealing ring 35x52x7	Dichtring, Durchm. 35x52x7	1
17	Cuscinetto tipo 6007	Palier 6007	Bearing 6007	Kugellager, Type 6007	2
18	Pignone	Pignon	Pinion gear	Ritzel	1
19	Tappo livello olio 3/8"	Bouchon niveau huile 3/8"	Oil level plug 3/8"	Ölstandschraube 3/8"	1
20	Dado M6	Ecrou M6	Nut M6	Mutter, M6	8
21	Spina 5x16	Goupille 5x16	Peg 5x16	Stift 5x16	2



SERIE 95000

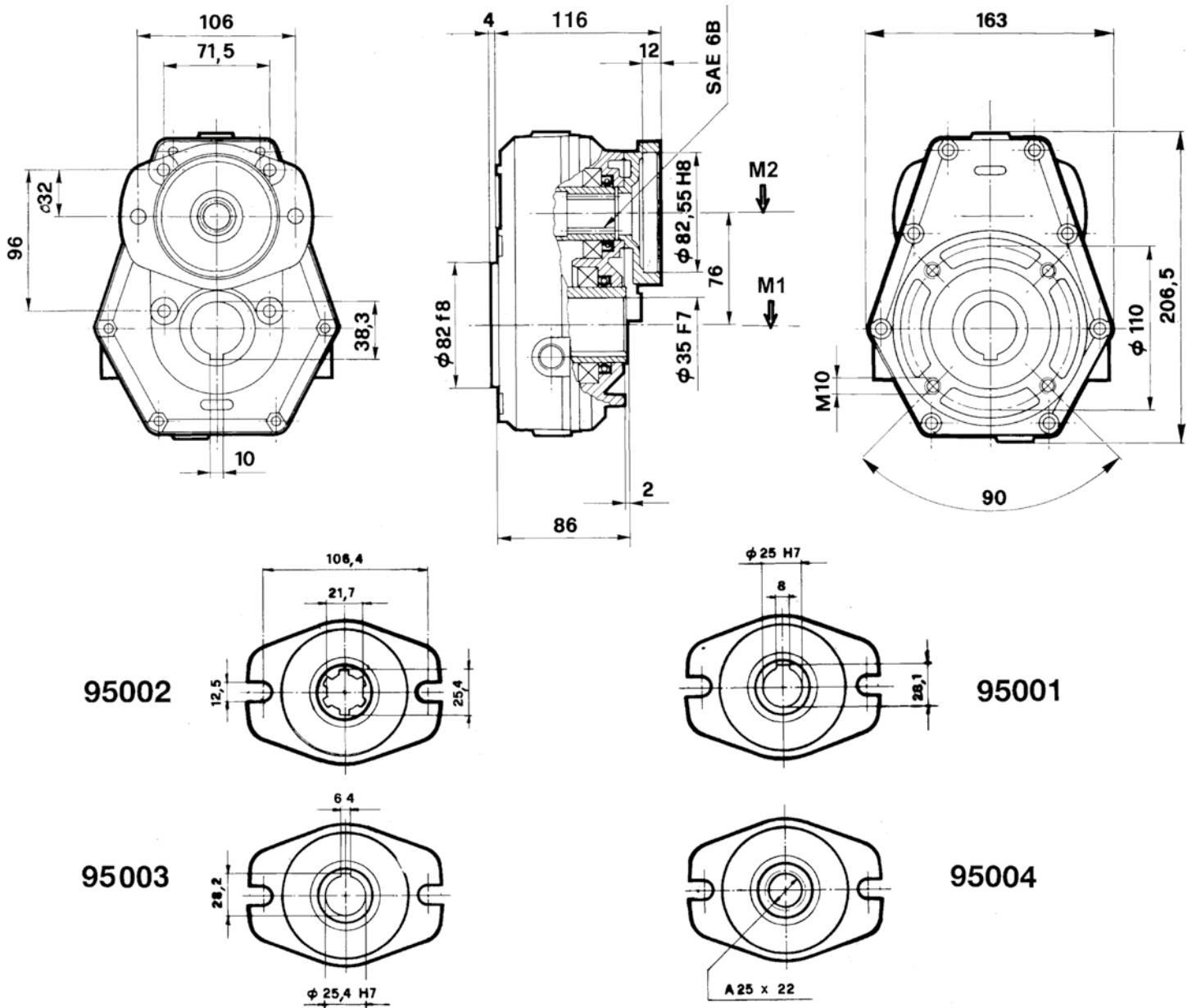

Livello max olio: it 0,220

M1 da Nm	M2 da Nm	N. 1 giri/1' tours/1' R.P.M U/min	N. 2 giri/1' tours/1' R.P.M U/min	I N.1/N.2	POTENZA Kw	P Kg
19,6	13,1	200	300	1,5	10	5
17,6	8,8	200	400	2	10	5
19,2	7,7	200	500	2,5	10	5
20,1	6,7	200	600	3	10	5
21,4	6,3	200	700	3,5	10	5
18,6	4,9	200	760	3,8	10	5



SERIE 96000

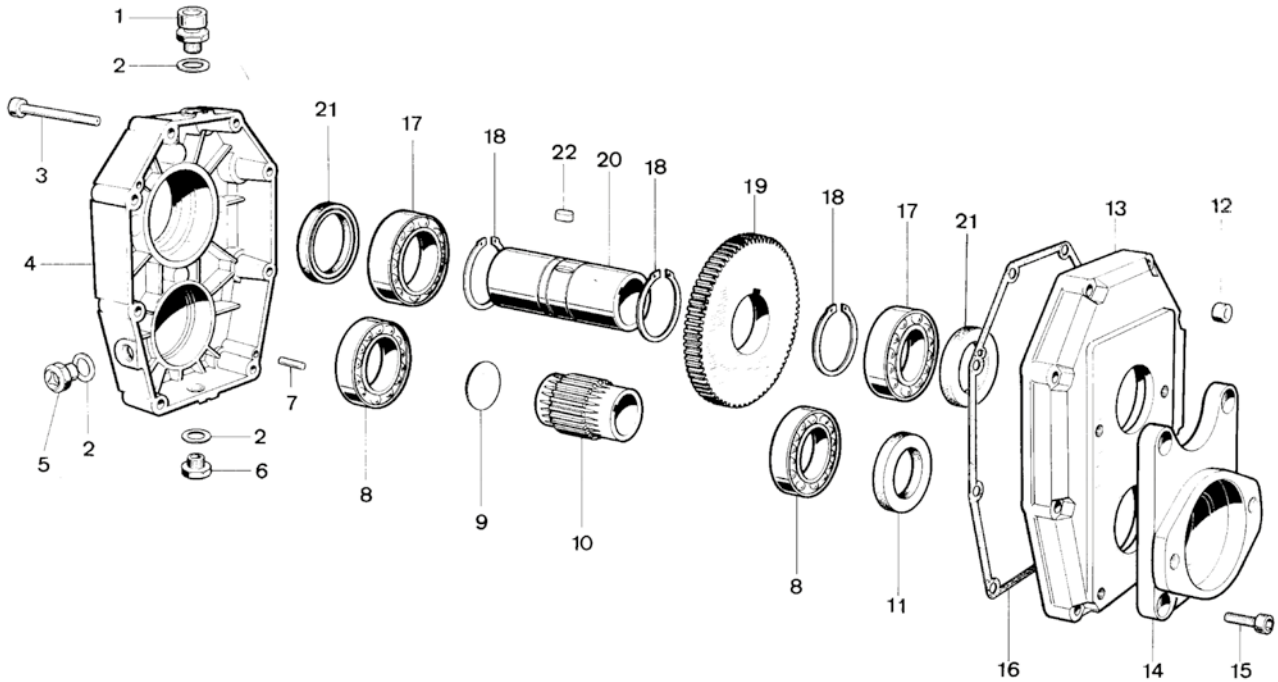

POS.	DENOMINAZIONE	DENOMINATION	DESCRIPTION	BEZEICHNUNG	Q.TÀ
1	Tappo sfiato olio 3/8"	Bouchon reniflard huile 3/8"	Oil breather plug 3/8"	Entlüftungsschraube 3/8"	1
2	Guarnizione	Joint	Gasket	Dichtung	3
3	Vite M8x70	Vis M8x70	Socket capscrew M8x70	Schraube M8x70	8
4	Scatola	Carcasse	Housing	Gehäuse	1
5	Tappo livello olio 3/8"	Bouchon niveau huile 3/8"	Oil level plug 3/8"	Ölstandsschraube 3/8"	1
6	Tappo scarico olio 3/8"	Bouchon vidange huile 3/8"	Oil drain plug 3/8"	Ölablaßschraube 3/8"	1
7	Spina 5x16	Goupille 5x16	Peg 5x16	Stift 5x16	2
8	Cuscinetto tipo 6009	Palier 6009	Bearing type 6009	Kugellager, Type 6009	2
9	Coperchietto D.37 DIN 470	Petit couvercle D.37 DIN 470	Cap D.37 DIN 470	Deckel D.37 DIN 470	1
9	Corona	Couronne	Ring gear	Zahnkranz	1
10	Pignone	Pignon	Pinion gear	Ritzel	1
11	Anello di tenuta \varnothing 45x65x8	Bague d'étanchéité 45x65x8	Sealing ring 45x65x8	Dichtring, Durchm. 45x65x8	1
12	Dado M8	Ecrou M8	Nut M8	Mutter M8	8
13	Coperchio	Couvercle	Cover	Deckel	1
14	Flangia SAE A	Bride SAE A	Flange SAE A	Flansch, SAE A	1
15	Vite M10x20	Vis M10x20	Screw M10x20	Schraube M10x20	4
16	Guarnizione	Joint	Gasket	Dichtung	1
17	Cuscinetto tipo 6010	Palier 6010	Bearing type 6010	Kugellager, Typ 6010	2
18	Seeger \varnothing 50	Circlip D. 50	Snap ring \varnothing 50	Seegerring, Durchm. 50	2
19	Corona	Couronne	Ring gear	Zahnkranz	1
20	Albero cavo \varnothing 35	Arbre creux \varnothing 35	Hollow shaft \varnothing 35	Hohlwelle, Durchm. \varnothing 35	1
21	Anello di tenuta \varnothing 50x65x8	Bague d'étanchéité 50x65x8	Sealing ring \varnothing 50x65x8	Dichtring, Durchm. 50x65x8	2
22	Chiavetta 12x25	Clavette 12x25	Key 12x25	Keil 12x25	1



SERIE 96000

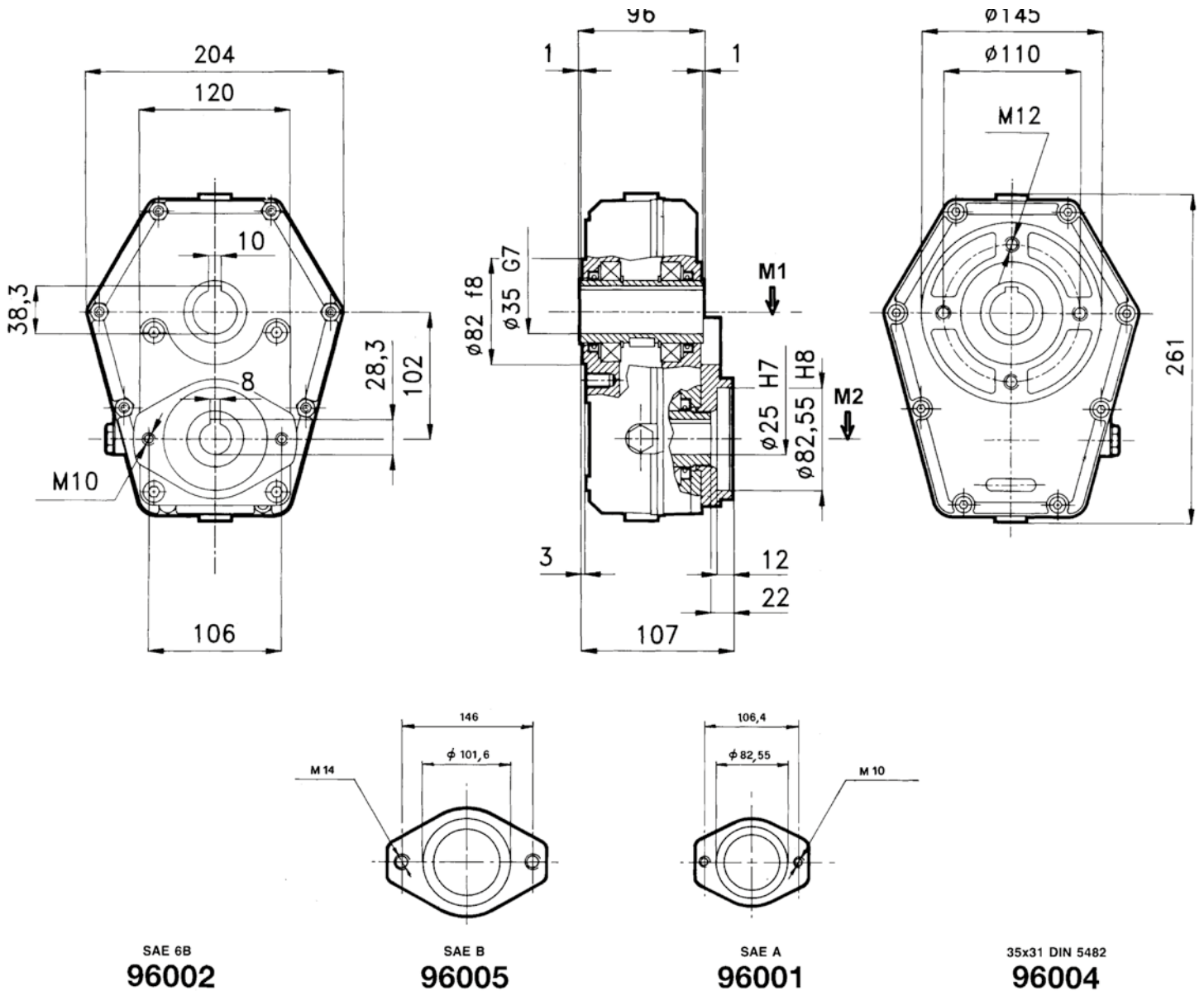

SAE 6B
96002

SAE B
96005

SAE A
96001

35x31 DIN 5482
96004

Livello max olio: it 0,350

M1 da Nm	M2 da Nm	N. 1 giri/1' tours/1' R.P.M U/min	N. 2 giri/1' tours/1' R.P.M U/min	I N.1/N.2	POTENZA Kw	P Kg
48	32	200	300	1,5	20	8,5
48,5	24,2	200	400	2	20	8,5
52	20,8	200	500	2,5	20	8,5
57	19	200	600	3	20	8,5
53	15,1	200	680	3,5	20	8,5
52,5	13,8	200	760	3,8	20	8,5



- TAVOLA RICAMBI RIDUTTORE IN GHISA Gr. 2 SAE A
- TABLEAU DES PIÈCES DÉTACHÉES DU REDUCTEUR EN FONTE Gr. 2 SAE A
- REDUCTION GEAR SPARE PARTS TABLE GROUP 2 SAE A CAST IRON
- ERSATZLISTE HUNTERSETZUNGSGETRIEBE Gr. 2 SAE A GUBEISEN

SERIE 97500

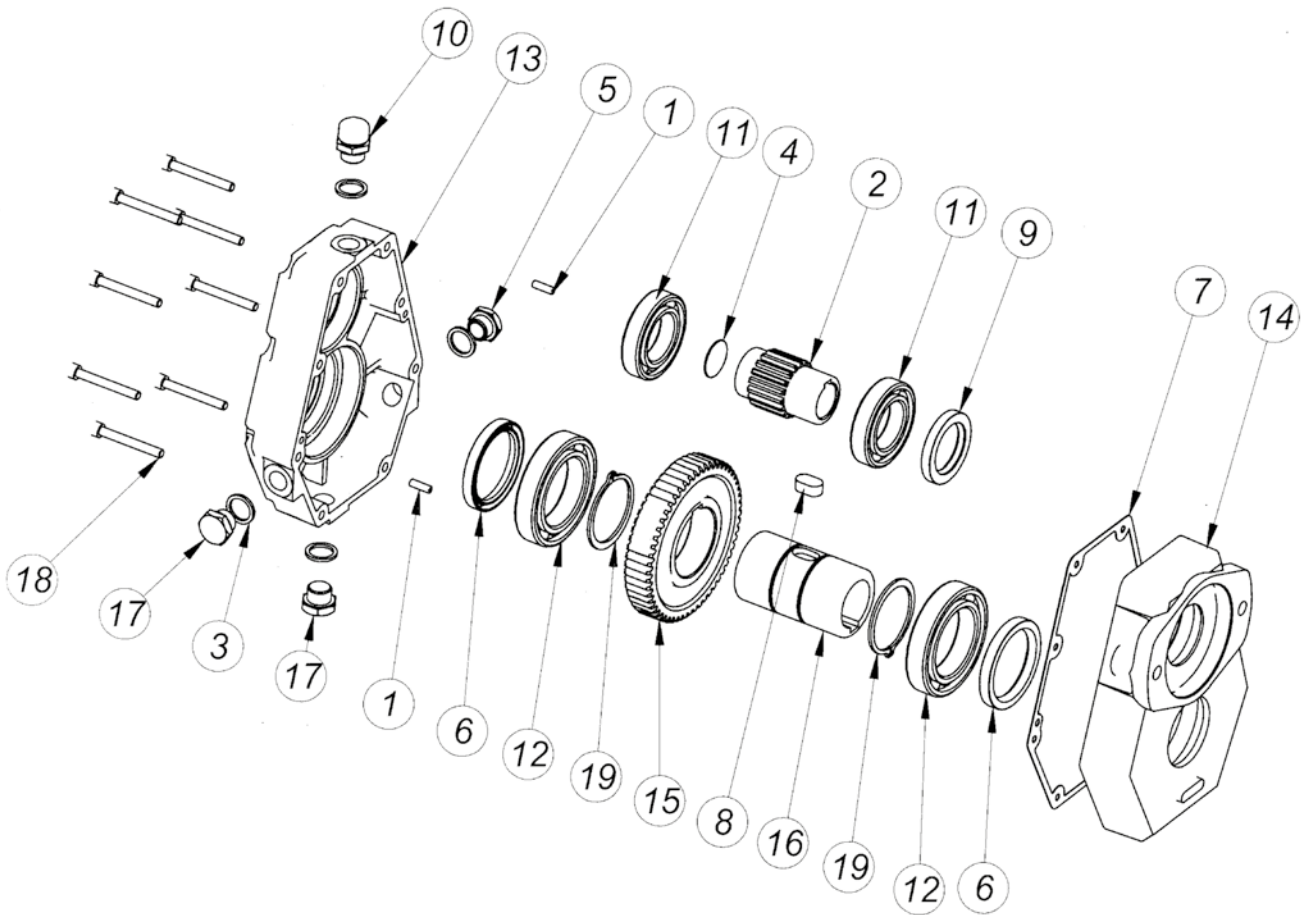

Pos.	DENOMINAZIONE	DENOMINATION	DESCRIPTION	BEZEICHNUNG	Q.TA'
1	Spina 5x16	Goupille 5x16	Peg 5x16	Stift durchm 5x16	2
2	Pignone	Pignon	Pinion gear	Ritzel	1
3	Guarnizione	Joint	Gasket	Dichtung	4
4	Coperchietto D.27 DIN 470	Petit couvercle D.27 DIN 470	Cap D.27 DIN 470	Deckel D.27 DIN 470	1
5	Tappo livello olio 3/8"	Bouchon niveau huile 3/8"	Oil drain plug 3/8"	Olstandschraube 3/8"	1
6	Anello di tenuta 50x65x8	Bague d'étanchéité 50x65x8	Sealing ring 50x65x8	Dichtring, Durchm. 50x65x8	2
7	Guarnizione	Joint	Gasket	Dichtung	1
8	Chiavetta 12x20	Clavette 12x20	Key 12x20	Keil 12x20	1
9	Anello di tenuta 35x52x7	Bague d'étanchéité 35x52x7	Sealing ring 35x52x7	Dichtring 35x52x7	1
10	Tappo sfiato olio 3/8"	Bouchon reniflard huile 3/8"	Oil breather plug 3/8"	Olablabschraube	1
11	Cuscinetto 6007	Palier 6007	Bearing 6007	Kugellager 6007	2
12	Cuscinetto tipo 6010	Palier 6010	Bearing 6010	Kugellager Type 6010	2
13	Scatola	Carcasse	Housing	Gehäuse	1
14	Coperchio	Couvercle	Cover	Deckel	1
15	Corona	Couronne	Ring gear	Zahnkranz	1
16	Albero cavo d. 35	Arbre creux d.35	Hollow shaft d.35	Hohlwelle Durchm. d.35	1
17	Tappo scarico olio	Bouchon vindage huile	Oil drain plug	Olablabschraube	2
18	Vite UNI 5931 M6x45	Vis UNI 5931 M6x45	Socket UNI 5931 M6x45	Zylinderkopfschraube mit Innensechskant M6x45	8
19	Anello seeger d.50	Circlip d.50	Snap ring d.50	Seegerring, Durchm. 50	2



- RIDUTTORE IN GHISA Gr. 2 SAE A
- REDUCTEUR EN FONTE Gr. 2 SAE A
- REDUCTION GEAR CAST IRON GROUP 2 SAE A
- HUNTERSETZUNGSGETRIEBE GUBEISEN Gr. 2 SAE A

SERIE 97500

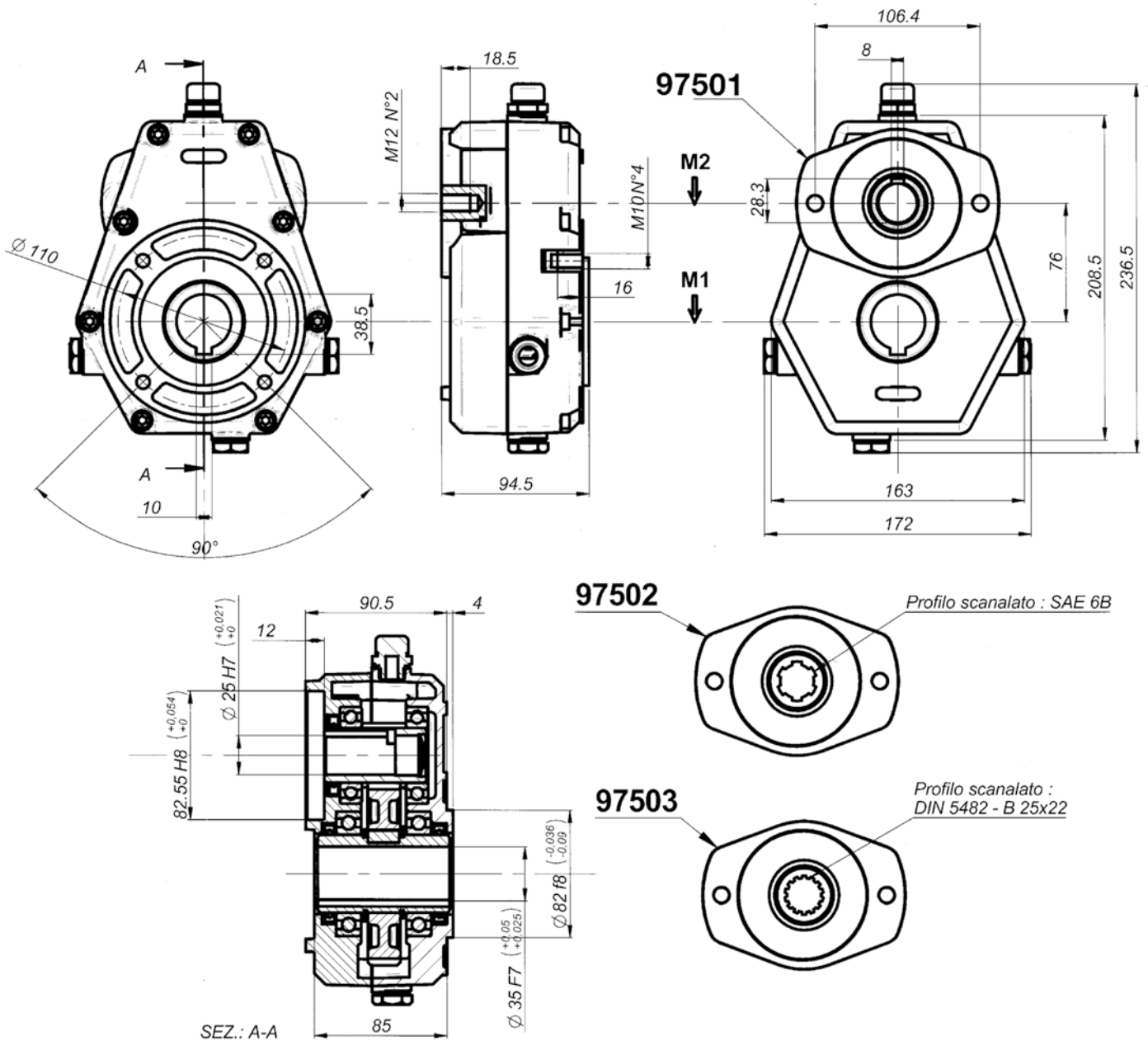

Livello max olio: it 0,220

M1 da Nm	M2 da Nm	N. 1 giri/1' tours/1' R.P.M U/min	N. 2 giri/1' tours/1' R.P.M U/min	I N.1/N.2	POTENZA Kw	G Kg
24,7	16,5	200	300	1,5	18	10
32,4	16,2	200	400	2	18	10
38,7	15,5	200	500	2,5	18	10
24	8,0	200	600	3	18	10
25,5	7,5	200	680	3,5	18	10
26,6	7,0	200	760	3,8	18	10



- TAVOLA RICAMBI RIDUTTORE Gr. 3 IN GHISA
- TABLEAU DES PIÈCES DÉTACHÉES DU REDUCTEUR Gr. 3 EN FONTE
- REDUCTION GEAR SPARE PARTS TABLE Gr. 3 CAST IRON
- ERSATZLISTE HUNTERSETZUNGSGETRIEBE Gr. 3 GUBEISEN

SERIE 97003

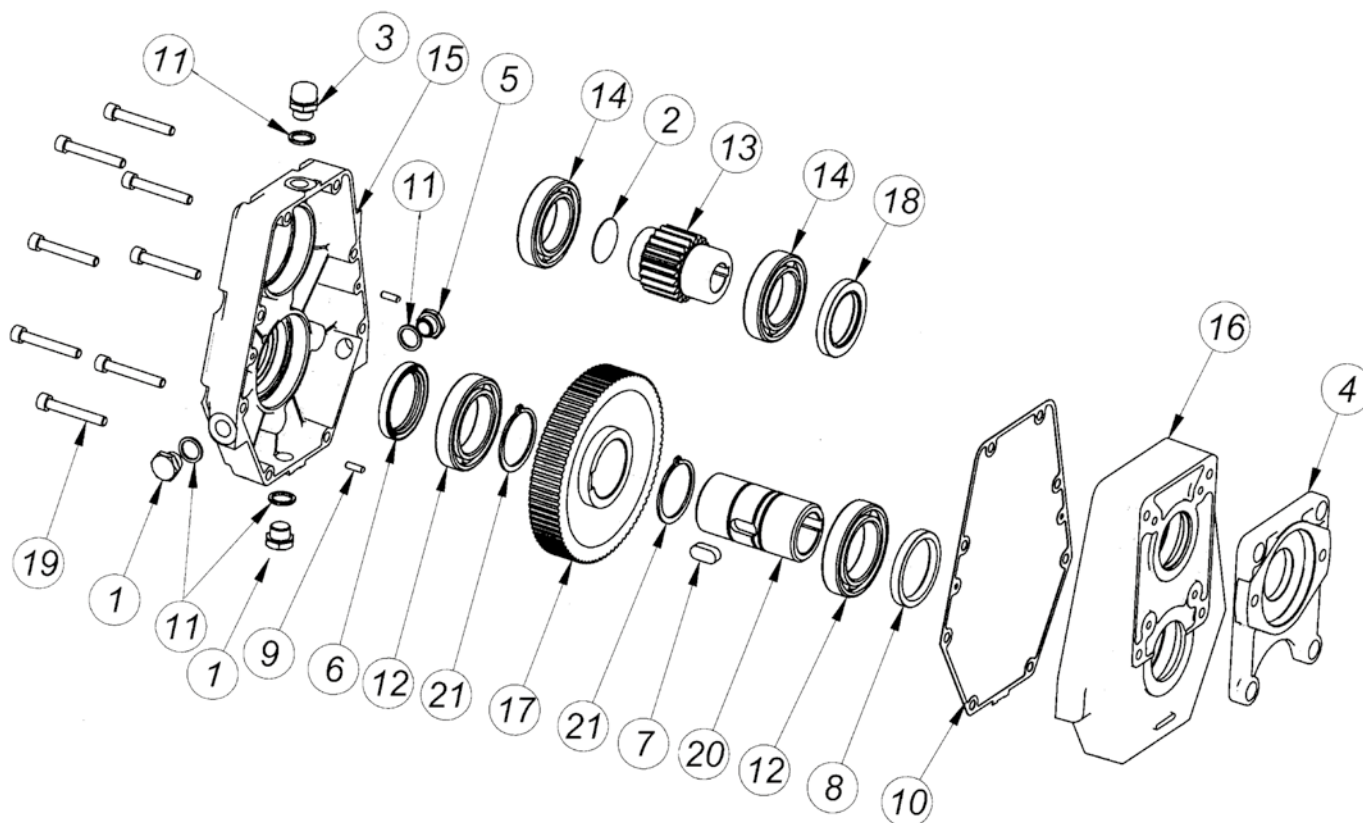

Pos.	DENOMINAZIONE	DENOMINATION	DESCRIPTION	BEZEICHNUNG	Q.TA'
1	Tappo scarico olio	Bouchon vindage huile	Oil drain plug	Olablabschraube	2
2	Coperchietto D.37 DIN 470	Petit couvercle D.37 DIN 470	Cap D.37 DIN 470	Deckel D.37 DIN 470	1
3	Tappo sfiato olio 3/8"	Bouchon reniflard huile 3/8"	Oil breather plug 3/8"	Olablabschraube	1
4	Flangia SAE A in Alluminio	Bride SAE A , Al	Flange SAE A , Al	Flansch SAE A , Al	1
5	Tappo livello olio 3/8"	Bouchon niveau huile 3/8"	Oil drain plug 3/8"	Olstandschrabe 3/8"	1
6	Anello di tenuta 50x65x8	Bague d'étanchéité 50x65x8	Sealing ring 50x65x8	Dichtring, Durchm. 50x65x8	1
7	Chiavetta 12x25	Clavette 12x25	Key 12x25	Keil 12x25	1
8	Anello di tenuta 50x65x8	Bague d'étanchéité 50x65x8	Sealing ring 50x65x8	Dichtring, Durchm. 50x65x8	1
9	Spina 5X20	Goupille 5X20	Peg 5X20	Stift 5X20	2
10	Guarnizione	Joint	Gasket	Dichtung	1
11	Guarnizione	Joint	Gasket	Dichtung	4
12	Cuscinetto tipo 6010	Palier 6010	Bearing 6010	Kugellager Type 6010	2
13	Pignone	Pignon	Pinion gear	Ritzel	1
14	Cuscinetto 6009	Palier 6009	Bearing 6009	Kugellager Type 6009	2
15	Scatola in ghisa	Carcasse en fonte	Housing cast iron	Gehäuse gubeisen	1
16	Coperchio in ghisa	Couvercle en fonte	Cover cast iron	Deckel gubeisen	1
17	Corona	Couronne	Ring gear	Zahnkranz	1
18	Anello di tenuta 45x65x8	Bague d'étancheité 45x65c8	Sealing ring 45x65x8	Dichtring, Durchm. 45x65x8	1
19	Vite T.C.E.I. M8x55	Vis T.C.H.C M8x55	Socket capscrew M8x55	Zylinderkopfschraube mit Innensechskant M8x55	8
20	Albero cavo ø 35	Arbre creux ø 35	Hollow shaft ø 35	Hohlwelle, durchm ø 35	1
21	Anello seeger d.50	Circlip d.50	Snap ring d.50	Seegerring, Durchm. 50	2



SERIE 97003

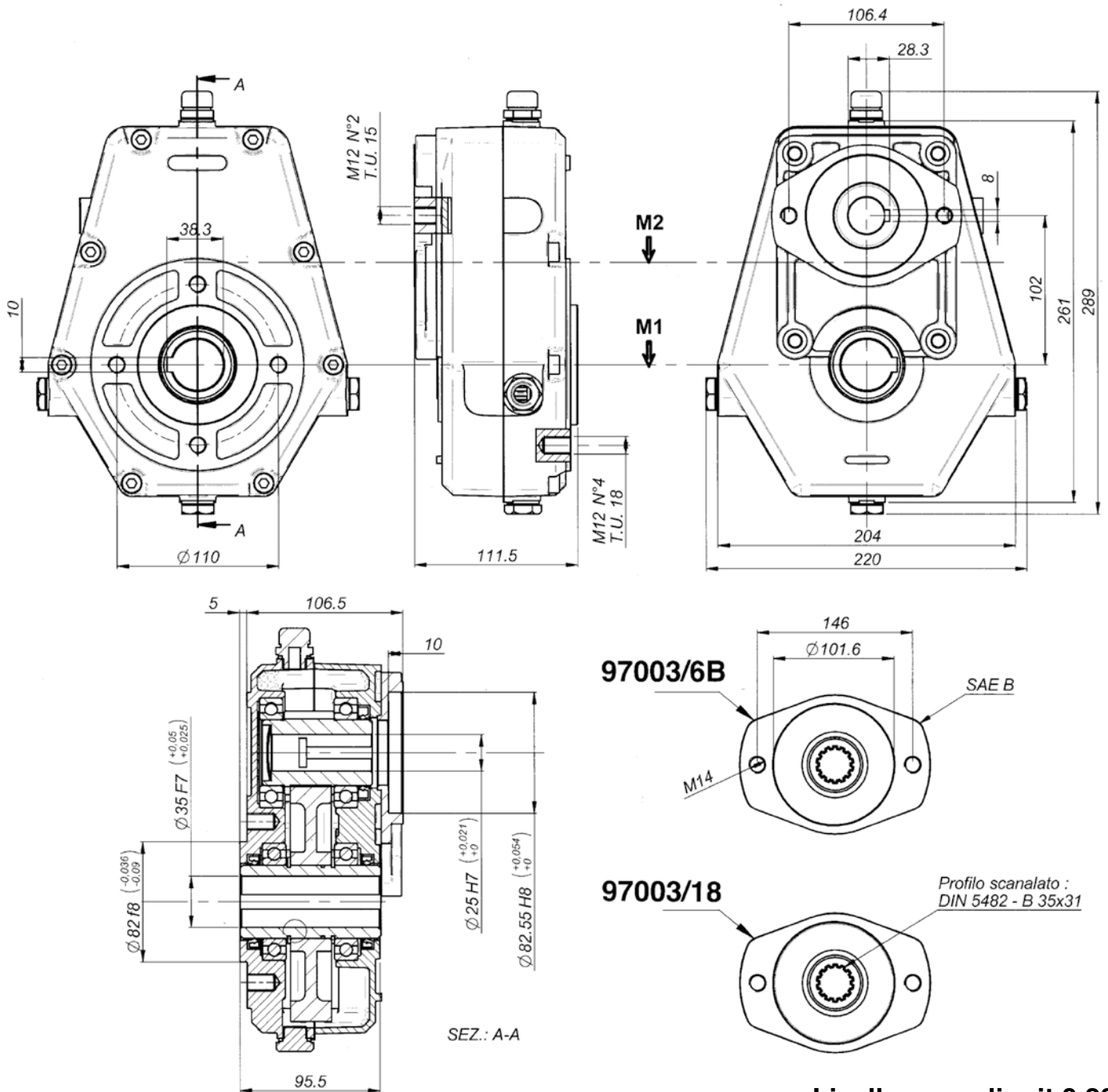

Livello max olio: it 0,220

M1 da Nm	M2 da Nm	N. 1 giri/1' tours/1' R.P.M U/min	N. 2 giri/1' tours/1' R.P.M U/min	I N.1/N.2	POTENZA Kw	G Kg
66	44	200	300	1,5	37	14,5
66	33	200	400	2	37	14,5
66	26,4	200	500	2,5	37	14,5
66	22	200	600	3	37	14,5
66	18	200	680	3,5	35	14,5
66	16,6	200	760	3,8	35	14,5



- TAVOLA RICAMBI RIDUTTORE IN GHISA Gr. 3 SAE A
- TABLEAU DES PIÈCES DÉTACHÉES DU REDUCTEUR EN FONTE Gr. 3 SAE A
- REDUCTION GEAR SPARE PARTS TABLE Gr. 3 SAE A CAST IRON
- ERSATZLISTE HUNTERSETZUNGSGETRIEBE Gr. 3 SAE A GUBEISEN

SERIE 97001

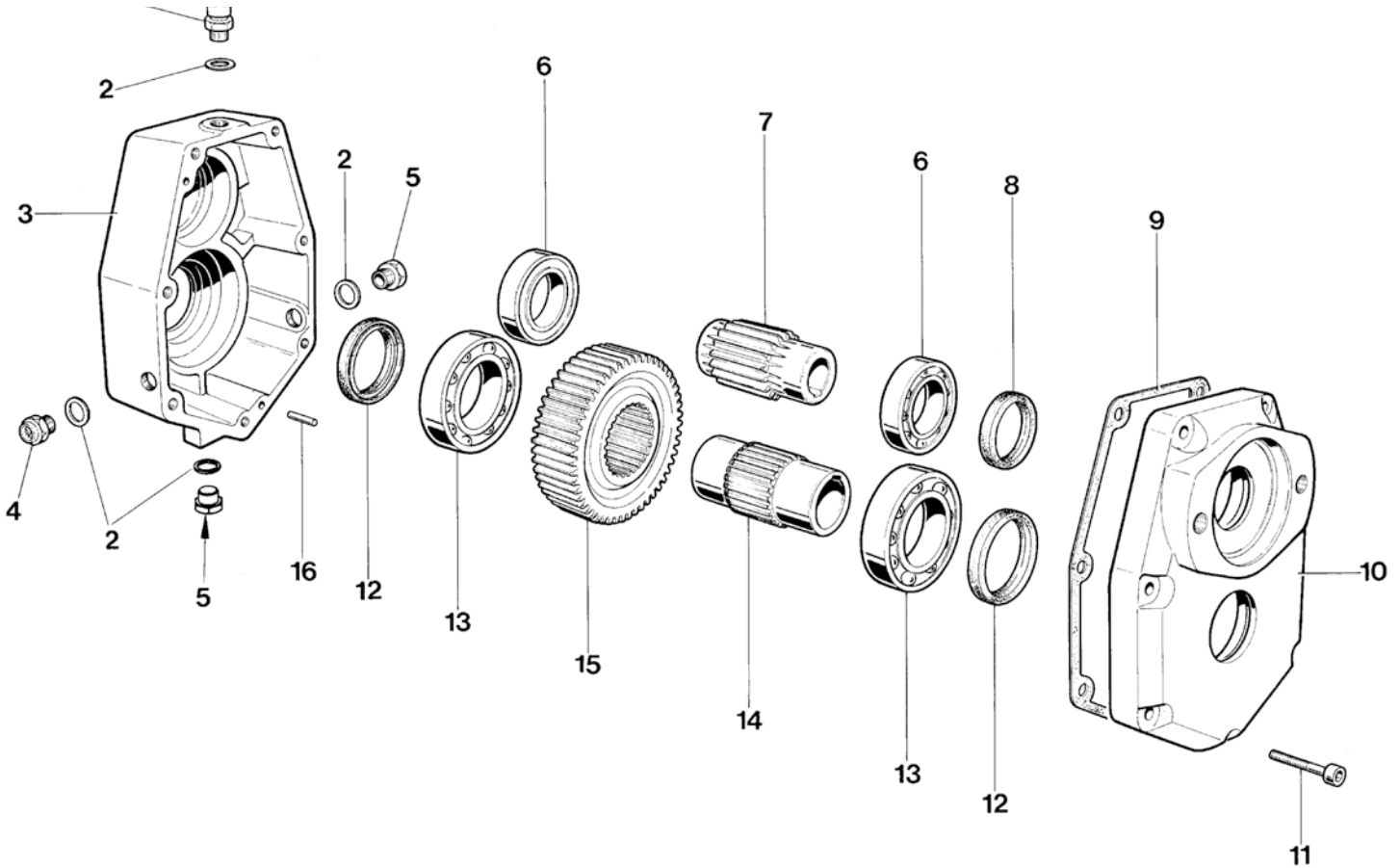

Pos.	DENOMINAZIONE	DENOMINATION	DESCRIPTION	BEZEICHNUNG	Q.TA'
1	Tappo sfiato olio 3/8"	Bouchon reniflard huile 3/8"	Oil breather plug 3/8"	Olablabschraube	1
2	Guarnizione	Joint	Gasket	Dichtung	4
3	Scatola	Carcasse	Housing	Gehäuse	1
4	Tappo livello olio 3/8"	Bouchon niveau huile 3/8"	Oil drain plug 3/8"	Olstandschrabe 3/8"	1
5	Tappo scarico olio	Bouchon vindage huile	Oil drain plug	Olablabschraube	2
6	Cuscinetto 6008	Palier 6008	Bearing 6008	Kugellager 6008	2
7	Pignone	Pignon	Pinion gear	Ritzel	1
8	Anello di tenuta 40x52x7	Bague d'étanchéité 40x52x7	Sealing ring 40x52x7	Dichtring 40x52x7	1
9	Guarnizione	Joint	Gasket	Dichtung	1
10	Coperchio SAE A	Couvercle SAE A	Cover SAE A	Deckel SAE A	1
11	Vite V.T.C.E.I M8x50	Vis V.T.C.E.I M8x50	Socket capscrew M8x50	Zylinderkopfschraube mit Innensechskant M8x50	7
12	Anello di tenuta 50x65x8	Bague d'étanchéité 50x65x8	Sealing ring 50x65x8	Dichtring, Durchm. 50x65x8	2
13	Cuscinetto 6210	Pallier 6210	Bearing 6210	Kugellager 6210	2
14	Albero cavo d. 35	Arbre creux d.35	Hollow shaft d.35	Hohlwelle Durchm. d.35	1
15	Corona	Couronne	Ring gear	Zahnkranz	1
16	Spina 5X16	Goupille 5X16	Peg 5X16	Stift 5X16	2



- RIDUTTORE IN GHISA Gr. 3 SAE A
- REDUCTEUR EN FONTE Gr. 3 SAE A
- REDUCTION GEAR CAST IRON GROUP 3 SAE A
- HUNTERSETZUNGSGETRIEBE GUBEISEN Gr. 3 SAE A

SERIE 97001

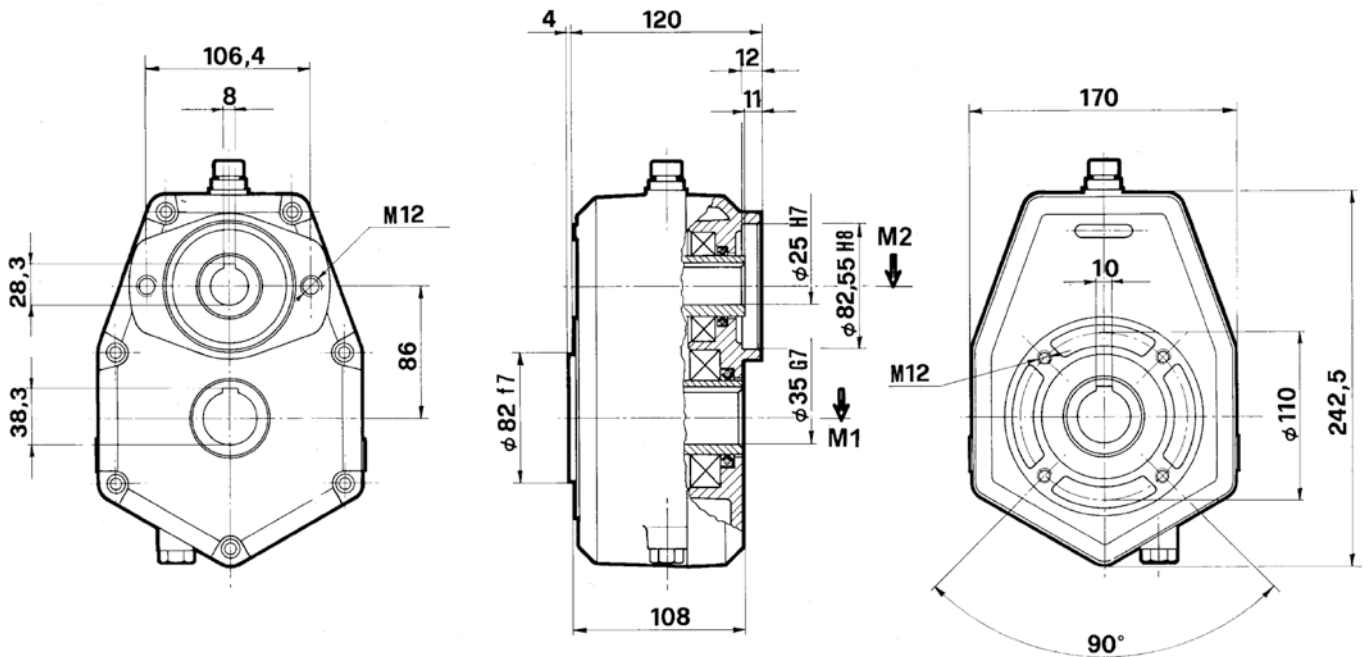

Livello max olio: it 0,300

M1 da Nm	M2 da Nm	N. 1 giri/1' tours/1' R.P.M U/min	N. 2 giri/1' tours/1' R.P.M U/min	I N.1/N.2	POTENZA Kw	G Kg
98	49	200	400	2	68	16
112,5	45	200	500	2,5	68	16
132	44	200	600	3	68	16



- TAVOLA RICAMBI RIDUTTORE IN GHISA Gr. 3 SAE B
- TABLEAU DES PIECES DETACHEES DU REDUCTEUR EN FONTE Gr. 3 SAE B
- REDUCTION GEAR SPARE PARTS TABLE Gr. 3 SAE B CAST IRON
- ERSATZTEILLISTE HUNTERSETZUNGSGETRIEBE Gr. 3 SAE B GUBEISEN

SERIE 97000

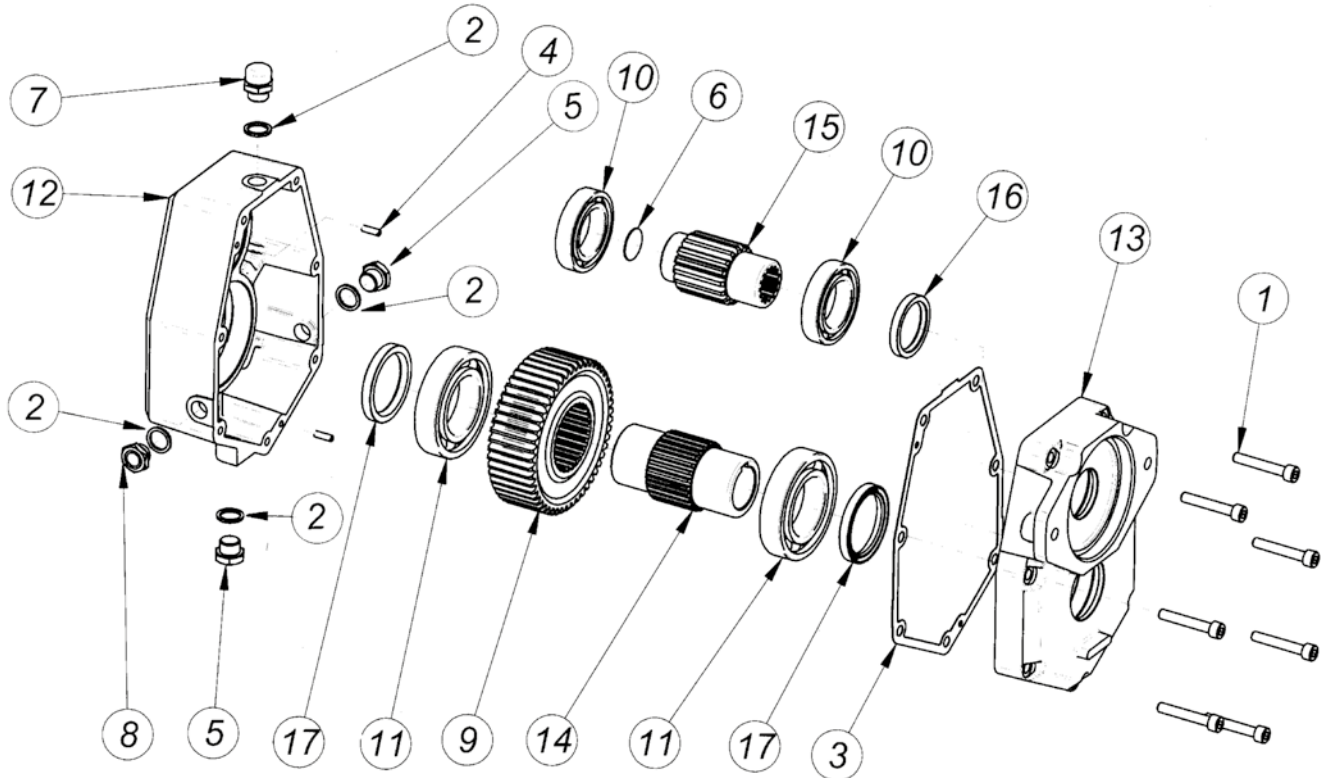

Pos.	DENOMINAZIONE	DENOMINATION	DESCRIPTION	BEZEICHNUNG	Q.TA'
1	Vite V.T.C.E.I M8x50	Vis V.T.C.E.I M8x50	Socket capscrew M8x50	Zylinderkopfschraube mit Innensechskant M8x50	7
2	Guarnizione	Joint	Gasket	Dichtung	4
3	Guarnizione	Joint	Gasket	Dichtung	1
4	Spina 5X16	Goupille 5X16	Peg 5X16	Stift 5X16	2
5	Tappo scarico olio	Bouchon vindage huile	Oil drain plug	Olablabschraube	2
6	Coperchietto D.27 DIN 470	Petit couvercle D.27 DIN 470	Cap D.27 DIN 470	Deckel D.27 DIN 470	1
7	Tappo sfiato olio 3/8"	Bouchon reniflard huile 3/8"	Oil breather plug 3/8"	Olablabschraube	1
8	Tappo livello olio 3/8"	Bouchon niveau huile 3/8"	Oil drain plug 3/8"	Olstandschrabe 3/8"	1
9	Corona	Couronne	Ring gear	Zahnkranz	1
10	Cuscinetto 6008	Palier 6008	Bearing 6008	Kugellager 6008	2
11	Cuscinetto 6210	Pallier 6210	Bearing 6210	Kugellager 6210	2
12	Scatola	Carcasse	Housing	Gehäuse	1
13	Coperchio SAE B	Couvercle SAE B	Cover SAE B	Deckel SAE B	1
14	Albero cavo d. 35	Arbre creux d.35	Hollow shaft d.35	Hohlwelle Durchm. d.35	1
15	Pignone	Pignon	Pinion gear	Ritzel	1
16	Anello di tenuta 40x52x7	Bague d'étanchéité 40x52x7	Sealing ring 40x52x7	Dichtring 40x52x7	1
17	Anello di tenuta 50x65x8	Bague d'étanchéité 50x65x8	Sealing ring 50x65x8	Dichtring, Durchm. 50x65x8	2



- RIDUTTORE IN GHISA Gr. 3 SAE B
- REDUCTEUR EN FONTE Gr. 3 SAE B
- REDUCTION GEAR CAST IRON GROUP 3 SAE B
- HUNTERSETZUNGSGETRIEBE GUBEISEN Gr. 3 SAE B

SERIE 97001/13 - 97001/15

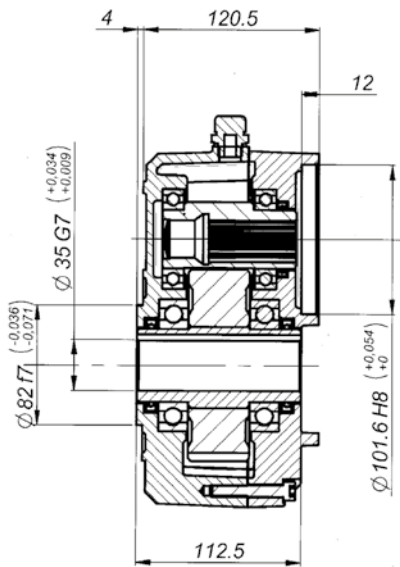
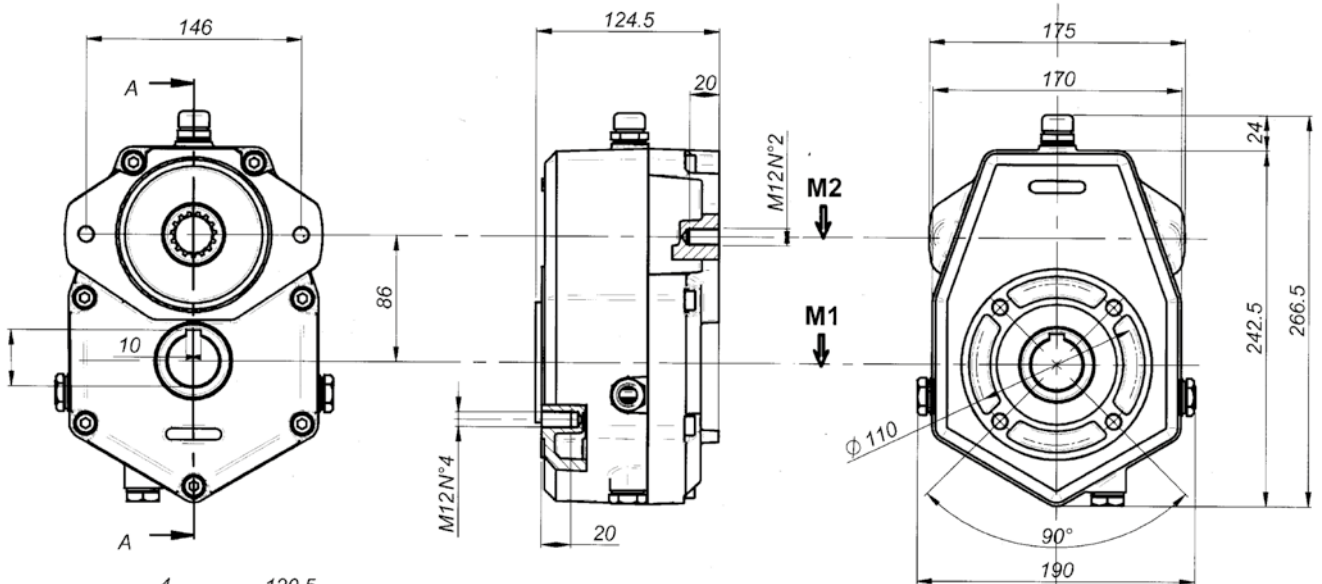

SEZ.: A-A

97001/13
Profilo : Z 13 SAE 16/32"

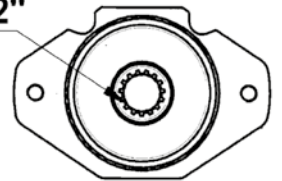

97001/15
Profilo : Z 15 SAE 16/32"

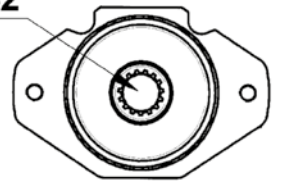

Livello max olio: it 0,300

M1 da Nm	M2 da Nm	N. 1 giri/1' tours/1' R.P.M U/min	N. 2 giri/1' tours/1' R.P.M U/min	I N.1/N.2	POTENZA Kw	G Kg
98	49	200	400	2	68	16
112,5	45	200	500	2,5	68	16
132	44	200	600	3	68	16

LubeTeam Hydraulic S.r.l.

Administration and Headquarter:

Via Tufara Scautieri, 6

83018 - San Martino Valle Caudina (AV)

Office and Warehouse:

S.S. 7 Appia, Km. 237,00

82011 - Airola BN

ITALY

Tel. +39 0823 950 994

Fax +39 0823 412 546

www.lubeteam.it info@lubeteam.it

Italian VAT / C.F. e P.IVA: 01251720627

Follow us



This document is the property of LubeTeam Hydraulic S.r.l. All data reported here are for the exclusive use of the Receiver. Reproduction is not authorized without writing permission, in all or in part of the content of this document, in accordance to Law 633 art. 171, dated April 22, 1941.

Il presente documento è di proprietà della LubeTeam Hydraulic S.r.l. I dati riportati sono per esclusivo del destinatario. La riproduzione, di tutto o in parte, non è autorizzata senza permesso scritto secondo l'art. 171 della L. 633 del 22 Aprile 1941.