



**BORELLI**  
Organi di trasmissione  
Supporti



 HYDRAULIC  
COMPONENTS  
& FLUID CONTAMINATION  
CONTROL



All trademarks belong to their respective owners; third party trademarks, product names, trade names, corporate names and company names mentioned may be trademarks of their respective owners or registered trademarks of other companies and are used for instructional purposes and for the benefit of the owner, without any end of Copyright infringement in force.

Tutti i marchi riportati appartengono ai legittimi proprietari; marchi di terzi, nomi di prodotti, nomi commerciali, nomi corporativi e società citati possono essere di proprietà dei rispettivi titolari o registrati da altre società e sono stati utilizzati a puro scopo esplicativo e a beneficio del possessore, senza alcun fine di violazione dei diritti di Copyright vigenti.



OLEODINAMICA **BORELLI**  
HYDRAULIC COMPONENTS

# catalogo SUPPORTI

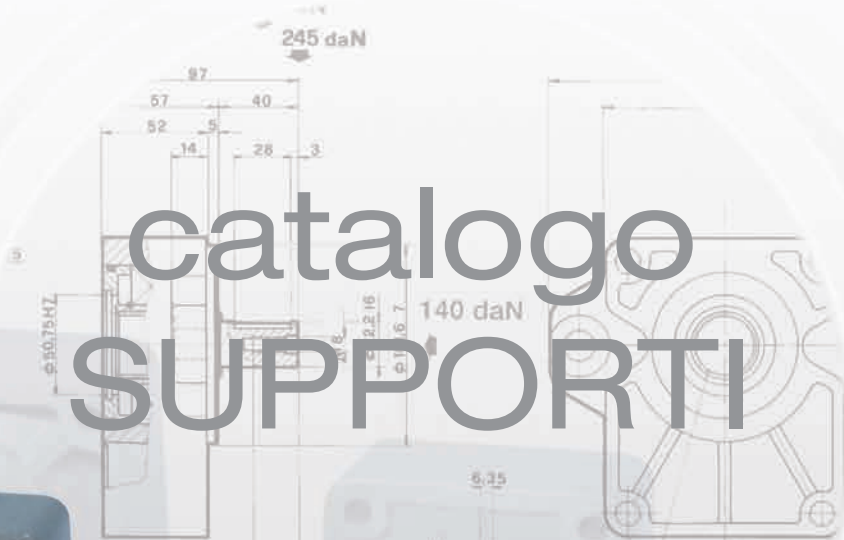



- SUPPORTI
- CONTRE-PALIERIS
- SUPPORTS
- HALTERUNGEN

I supporti tiro-cinghia vengono utilizzati per trasmissioni indipendenti di pompe oleodinamiche tramite cinghie o catene in cui sono presenti forti carichi radiali. Essi vengono flangiati direttamente alla pompa, e, l'accoppiamento viene fatto mediante semigiunto scanalato.

La durata dei supporti è di 3500 ore a 1500 g/1'.

**Lubrificazione:**

Grasso secondo norme DIN 51502 - MPF - 1K - 20.

---

*Les contre-paliers tire-courroie sont employés pour les transmissions indépendantes de pompes hydrauliques par courroie ou par chaînes où sont présentes des grandes charges radiales. Ils sont directement bridés à la pompe et l'accouplement se fait par un demiaccouplement cannelé.*

*La durée des contre-paliers est de 3500 heures à 1500 trs/mn.*

**Lubrification:**

Graisse aux normes DIN 51502 = MPF-1K-20.

---

*Designed for independent drives of hydraulic pumps via chain belts with high radial loads. They are directly flanged on to the pump via splined half-coupling. Their life is 3500 hours at 1500 R.P.M.*

**Lubrication:**

Grease according to DIN 51502 standards = MPF 1K-20.

---

*Die Riemenantriebhalterungen werden für unabhängige Riemen oder Kettenantriebe von Hydraulikpumpen verwendet, bei denen starke Radiallasten auftreten. Die Halterungen werden direkt an die Pumpe geflanscht und die Kupplung erfolgt mit genuteten Halbkupplungen. Die Lebensdauer der Halterungen ist 3500 Betriebsstunden bei 1500/min-1.*

**Schmierung:**

Fett nach DIN 51502: MPF - 1K - 20.



SERIE: 25401/25601

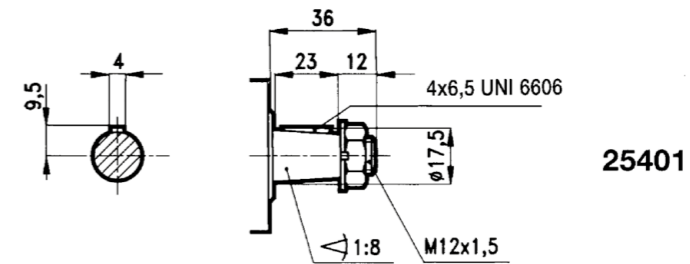
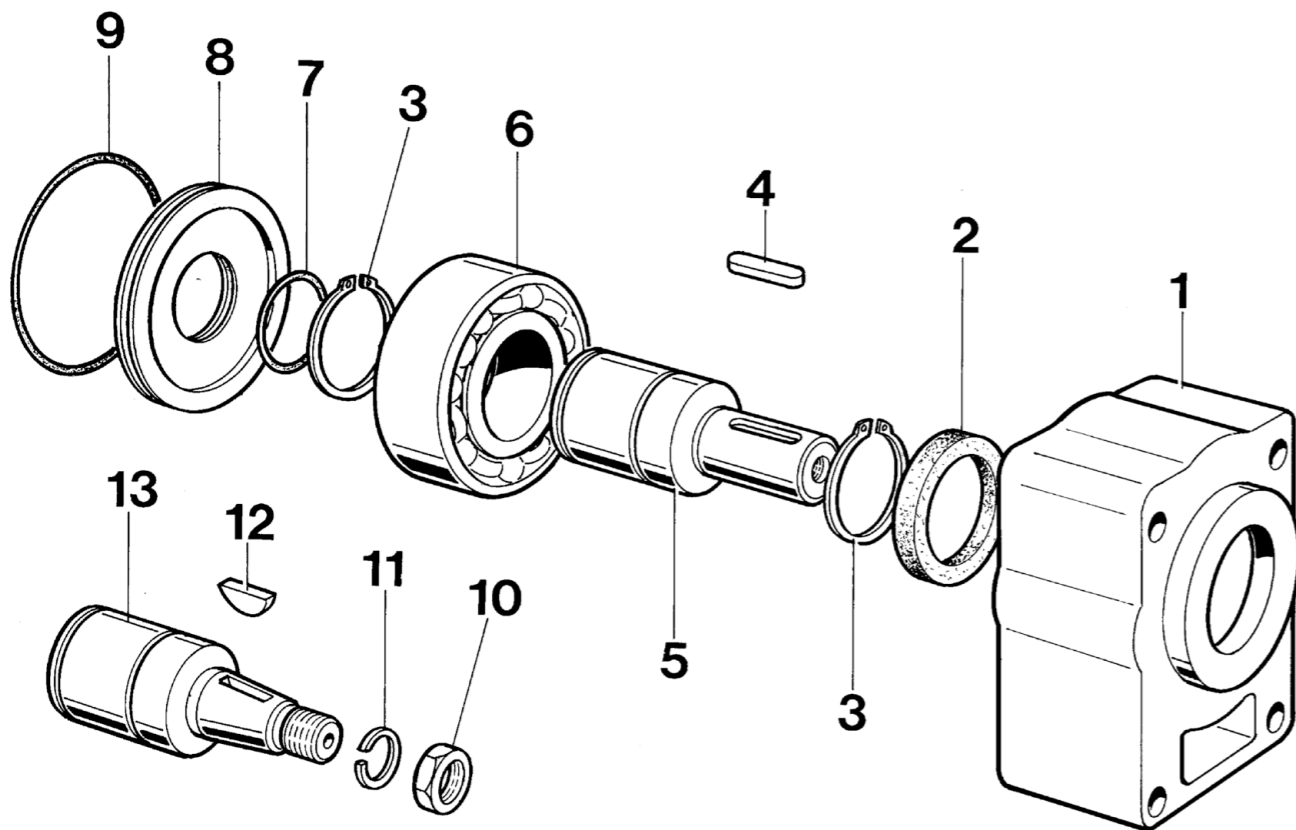

25401

100 daN.  
75 daN.

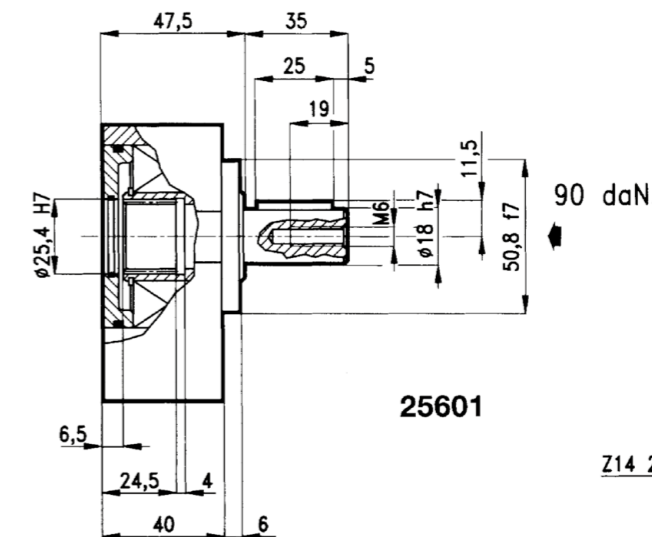
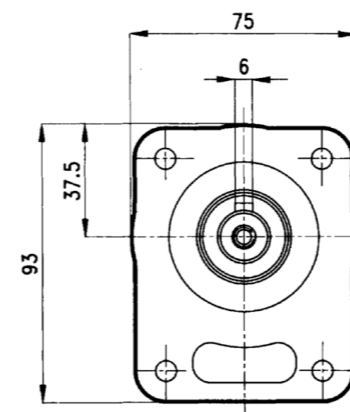

25601

Z14 25x22 DIN5482

Ø7

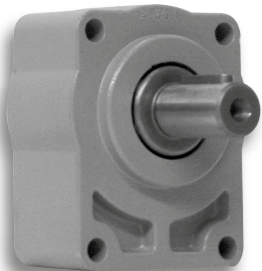

Pos.	CODICE	DENOMINAZIONE	DENOMINATION	DESCRIPTION	BEZEICHNUNG	Q.TA'
1	25001.1	Scatola	Carcasse	Housing	Gehäuse	1
2	303040	Anello di tenuta 30x40x7	Bague d'étanchéité 30x40x7	Sealing Ring 30x40x7	Dichtring 30x40x7	1
3	903000	Anello seeger UNI 7435 - 30	Circlip UNI 7435 - 30	Snap ring UNI 7435 - 30	Seegerring UNI 7435 - 30	2
4	426625	Chiavetta 6x6x25 UNI 6604	Clavette 6x6x25 UNI 6604	Key 6x6x25 UNI 6604	Keil 6x6x25 UNI 6604	1
5	AC18.1	Albero D=18	Arbre d=18	Female d=18	Antriebsw d=18	1
6	503206	Cuscinetto 3206A	Palier 3206A	Bearing 3206A	Kugellager 3206A	1
7	402100	Anello OR 2100	Bague torique 2100	O-Ring 2100	O-Ring 2100	1
8	COP062	Anello d=62	Bague d=62	Ring d=62	Ring d=62	1
9	403225	Anello OR 3225	Bague torique OR3225	O-Ring 3225	O-Ring 3225	1
10	601215	Dado UNI 28675 M12X1.5	Ecrous UNI 28675 M12x1.5	Nut UNI 28675 M12x1.5	Mutter UNI 28675 M12x1.5	1
11	801200	Rondella Grower d.12	Rondelle Grower d.12	Wascher Grower d.12	Rosette Grower d.12	1
12	700465	Chiavetta 4x6.5 UNI 6606	Clavette 4x6.5 UNI 6606	Key 4x6.5 UNI 6606	Keil 4x6.5 UNI 6606	1
13	ACO1	Albero conico	Arbre	Female	Antriebsw	1

SERIE: 25402/25602

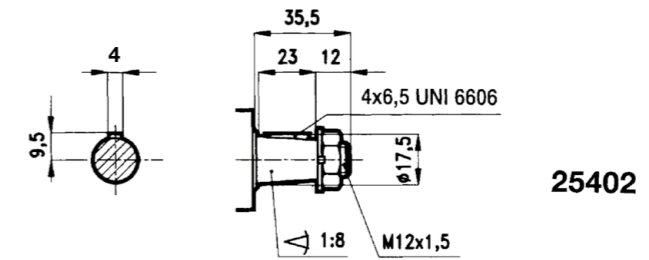
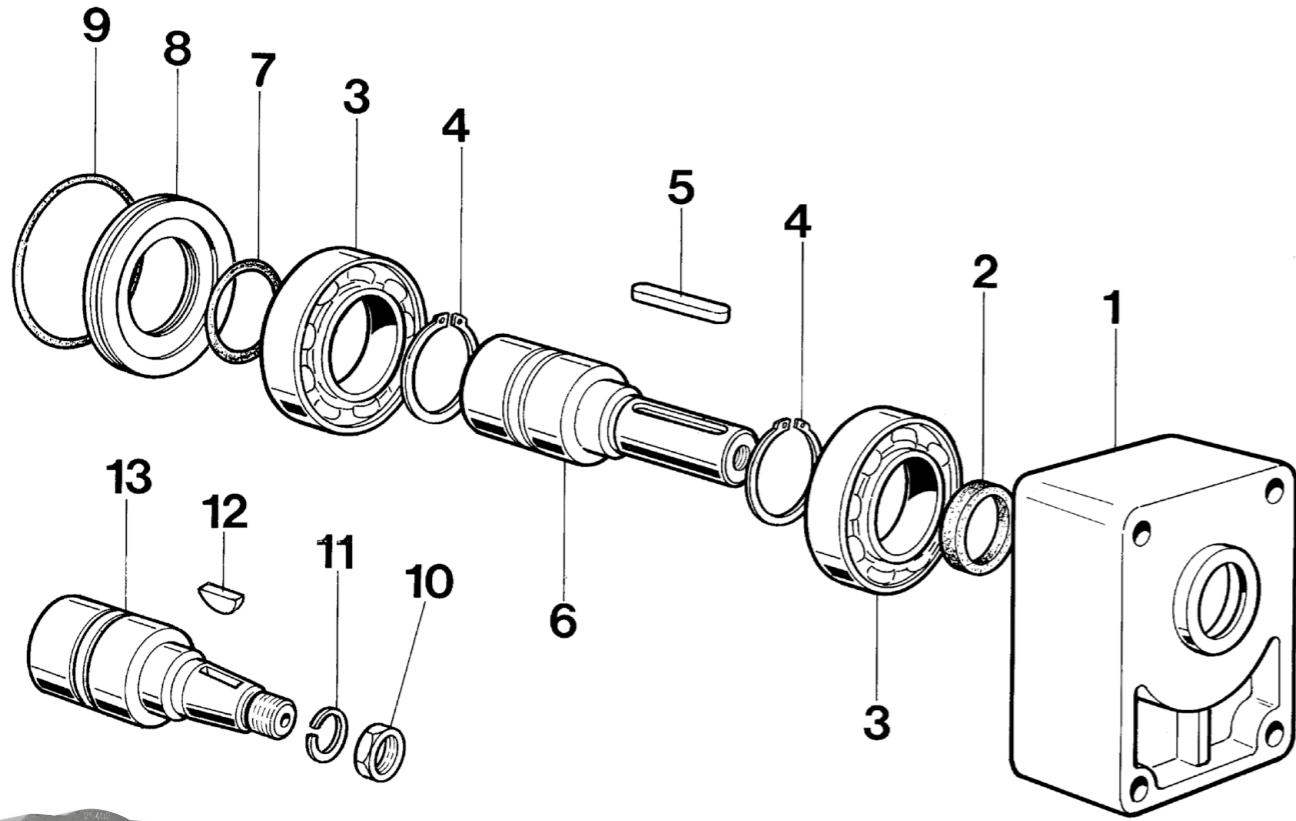

25402

170 daN.  
130 daN.

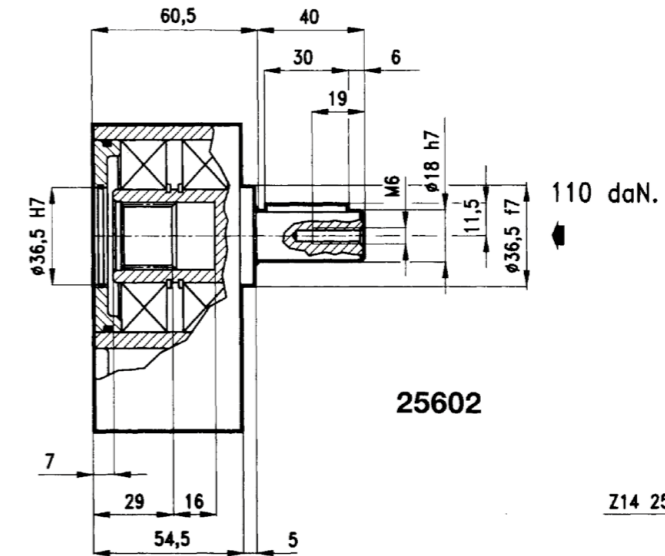
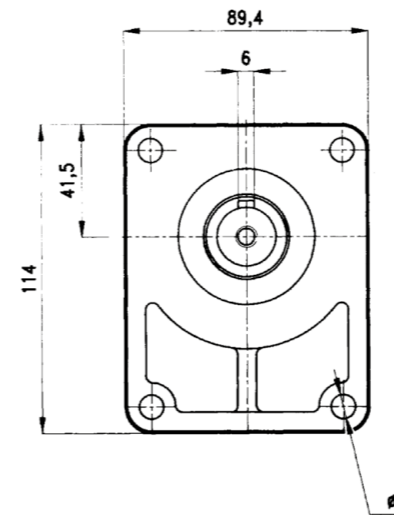

25602

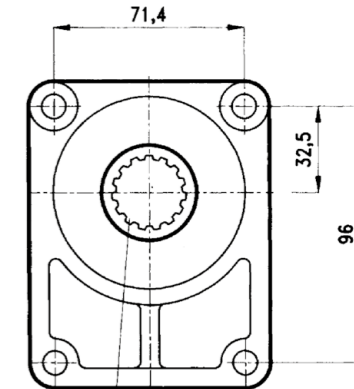

Z14 25x22 DIN5482

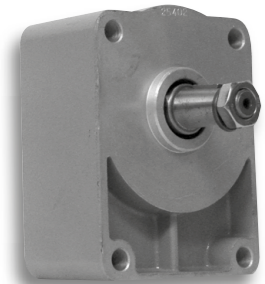

Pos.	CODICE	DENOMINAZIONE	DENOMINATION	DESCRIPTION	BEZEICHNUNG	Q.TA'
1	25002/364.1	Scatola	Carcasse	Housing	Gehäuse	1
2	302232	Anello di tenuta 22x32x7	Bague d'étanchéité 22x32x7	Sealing Ring 22x32x7	Dichtring 22x32x7	1
3	506207	Cuscinetto 6207A	Palier 6207A	Bearing 6207A	Kugellager 6207A	2
4	903500	Anello seeger UNI 7435 - 35	Circlip UNI 7435 - 35	Snap ring UNI 7435 - 35	Seegerring UNI 7435 - 35	2
5	426630	Chiavetta 6x6x30 UNI 6604	Clavette 6x6x30 UNI 6604	Key 6x6x30 UNI 6604	Keil 6x6x30 UNI 6604	1
6	AC18.2	Albero D=18	Arbre d=18	Female d=18	Antriedsw d=18	1
7	403143	Anello OR 3143	Bague torique 3143	O-Ring 3143	O-Ring 3143	1
8	25002/C.1	Anello d=72	Bague d=72	Ring d=72	Ring d=72	1
9	403262	Anello OR 3262	Bague torique OR 3262	O-Ring 3262	O-Ring 3262	1
10	601215	Dado UNI 28675 M12X1.5	Ecrous UNI 28675 M12x1.5	Nut UNI 28675 M12x1.5	Mutter UNI 28675 M12x1.5	1
11	801200	Rondella Grower d.12	Rondelle Grower d.12	Wascher Grower d.12	Rosette Grower d.12	1
12	700465	Chiavetta 3.2x6.5 UNI 6606	Clavette 3.2x6.5 UNI 6606	Key 3.2x6.5 UNI 6606	Keil 3.2x6.5 UNI 6606	1
13	ACO2	Albero conico	Arbre	Female	Antriedsw	1

SERIE: 25403/25603

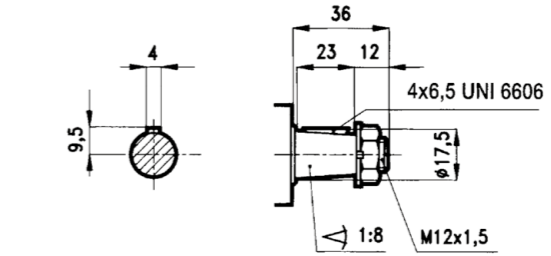
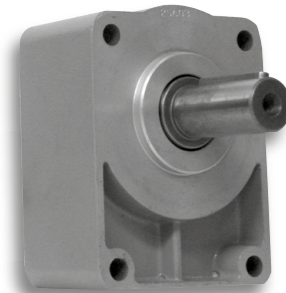
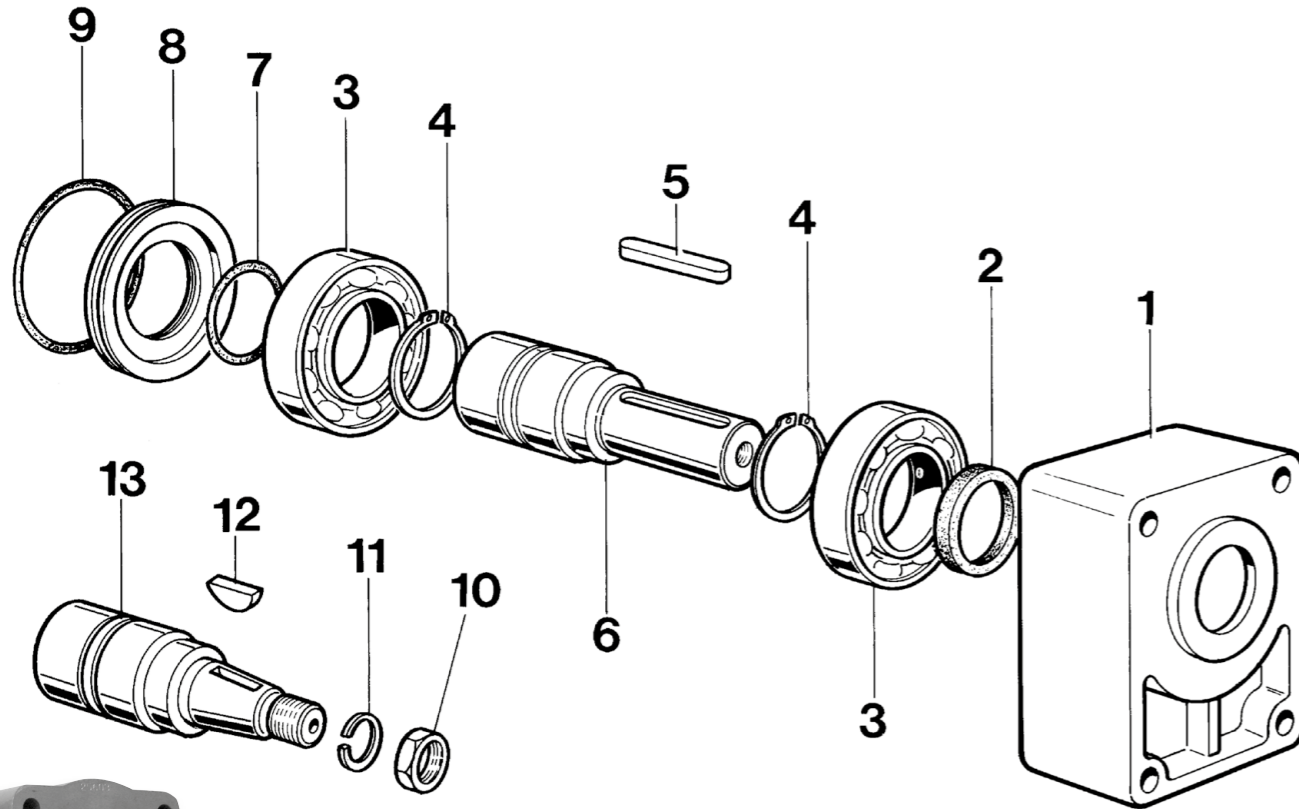

25403

285 daN.  
220 daN.

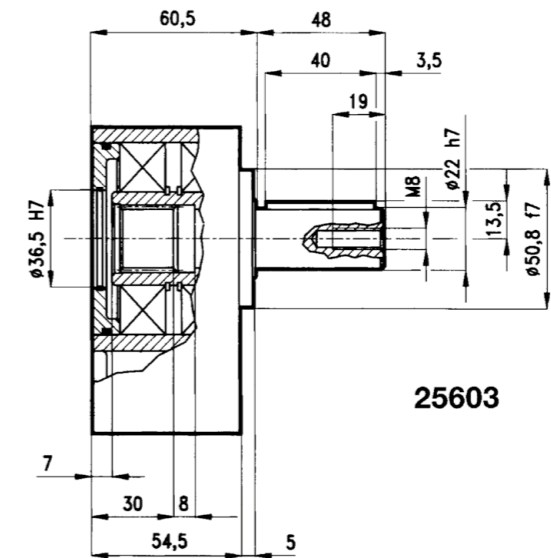
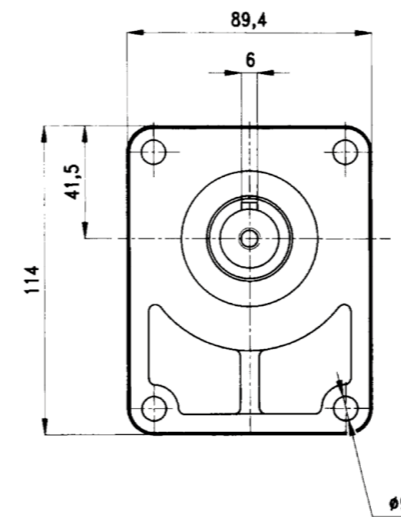

25603

130 daN.

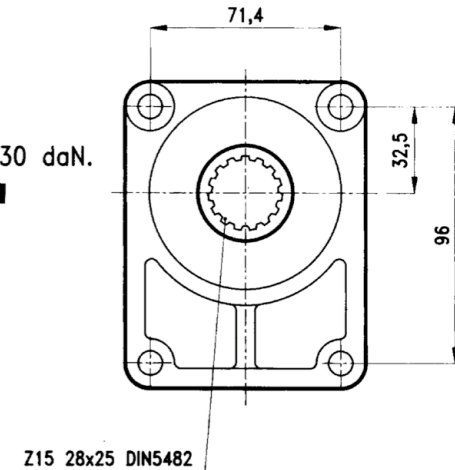

Pos.	CODICE	DENOMINAZIONE	DENOMINATION	DESCRIPTION	BEZEICHNUNG	Q.TA'
1	25003.1	Scatola	Carcasse	Housing	Gehäuse	1
2	303040	Anello di tenuta 30x40x7	Bague d'étanchéité 30x40x7	Sealing Ring 30x40x7	Dichtring 30x40x7	1
3	506207	Cuscinetto 6207A	Palier 6207A	Bearing 6207A	Kugellager 6207A	2
4	903500	Anello seeger UNI 7435 - 35	Circlip UNI 7435 - 35	Snap ring UNI 7435 - 35	Seegerring UNI 7435 - 35	2
5	426640	Chiavetta 6x6x40 UNI 6604	Clavette 6x6x40 UNI 6604	Key 6x6x40 UNI 6604	Keil 6x6x40 UNI 6604	1
6	AC22/R2	Albero D=22	Arbre d=22	Female d=22	Antriebsw d=22	1
7	403143	Anello OR 3143	Bague torique 3143	O-Ring 3143	O-Ring 3143	1
8	25002/C.1	Anello d=72	Bague d=72	Ring d=72	Ring d=72	1
9	403262	Anello OR 3262	Bague torique OR 3262	O-Ring 3262	O-Ring 3262	1
10	601215	Dado UNI 28675 M12x1.5	Ecrous UNI 28675 M12x1.5	Nut UNI 28675 M12x1.5	Mutter UNI 28675 M12x1.5	1
11	801200	Rondella Grower d.12	Rondelle Grower d.12	Wascher Grower d.12	Rosette Grower d.12	1
12	700465	Chiavetta 3.2x6.5 UNI 6606	Clavette 3.2x6.5 UNI 6606	Key 3.2x6.5 UNI 6606	Keil 3.2x6.5 UNI 6606	1
13	ACO2/R2	Albero conico	Arbre	Female	Antriebsw	1



SERIE: 25403.1/25603.1

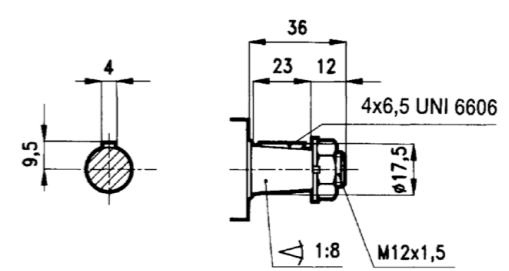
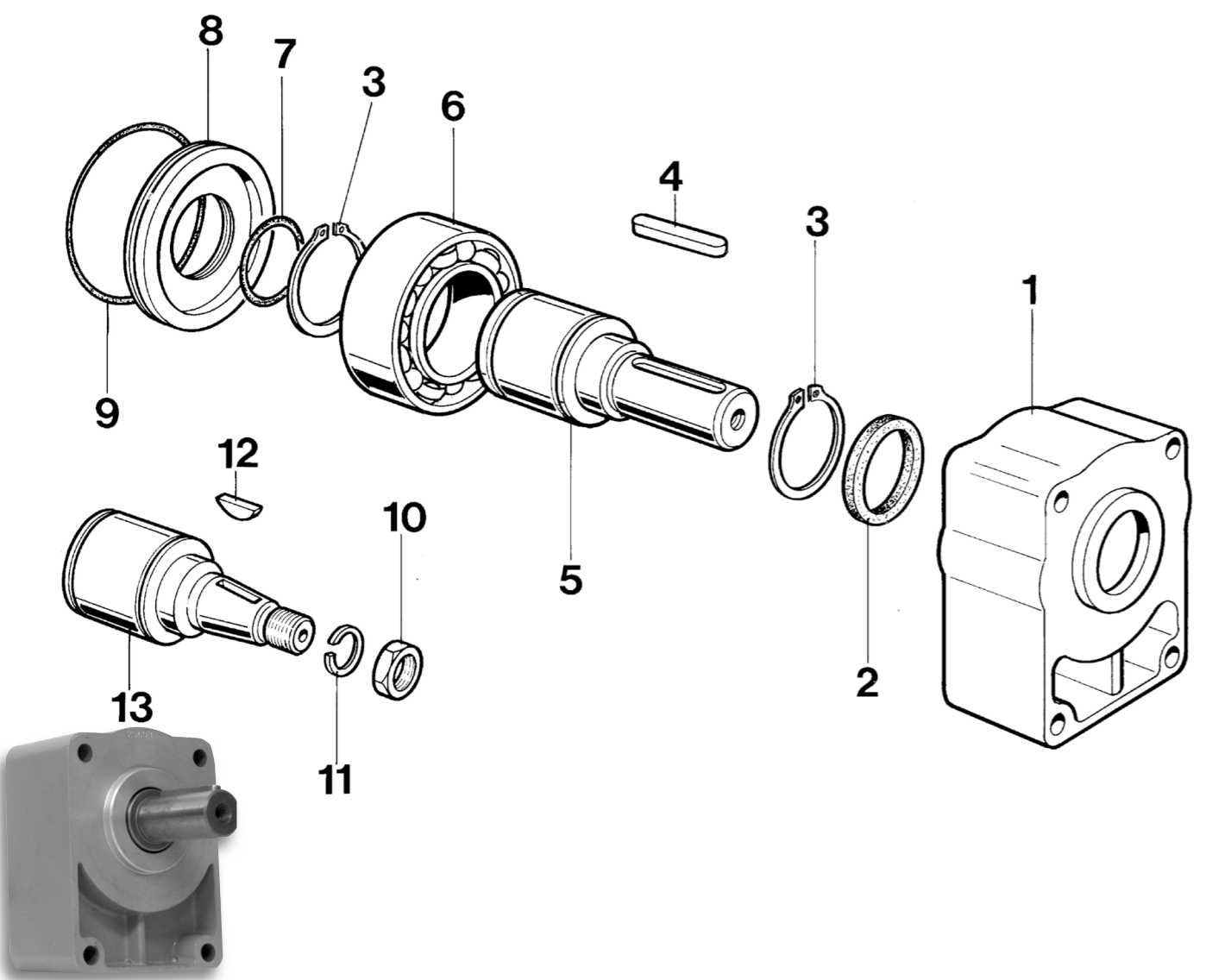

25403.1

285 daN. 220 daN.

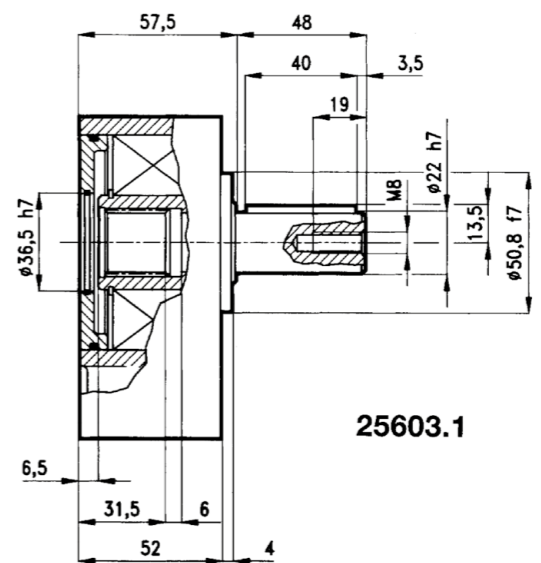
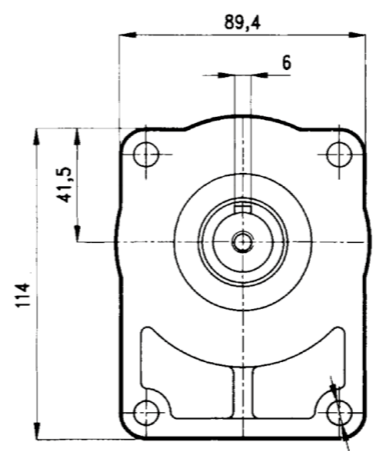

25603.1

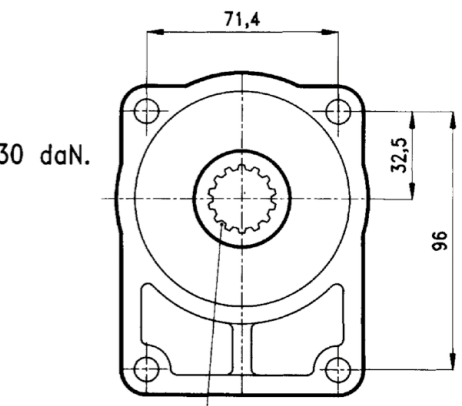

Pos.	CODICE	DENOMINAZIONE	DENOMINATION	DESCRIPTION	BEZEICHNUNG	Q. TA'
1	25003/508.1	Scatola	Carcasse	Housing	Gehäuse	1
2	303040	Anello di tenuta 30x40x7	Bague d'étanchéité 30x40x7	Sealing Ring 30x40x7	Dichtring 30x40x7	1
3	904000	Anello seeger UNI 7435 - 40	Circlip UNI 7435 - 40	Snap ring UNI 7435 - 40	Seegerring UNI 7435 - 40	2
4	426640	Chiavetta 6x6x40 UNI 6604	Clavette 6x6x40 UNI 6604	Key 6x6x40 UNI 6604	Keil 6x6x40 UNI 6604	1
5	AC22/R	Albero D=22	Arbre d=22	Female d=22	Antriebsw d=22	1
6	503208	Cuscinetto 3208A	Palier 3208A	Bearing 3208A	Kugellager 3208A	1
7	403143	Anello OR 3143	Bague torique 3143	O-Ring 3143	O-Ring 3143	1
8	25003/C.1	Anello d=80	Bague d=80	Ring d=80	Ring d=80	1
9	401740	Anello OR 174	Bague torique OR174	O-Ring 174	O-Ring 174	1
10	601215	Dado UNI 28675 M12x1.5	Ecrous UNI 28675 M12x1.5	Nut UNI 28675 M12x1.5	Mutter UNI 28675 M12x1.5	1
11	801200	Rondella Grower d.12	Rondelle Grower d.12	Wascher Grower d.12	Rosette Grower d.12	1
12	700365	Chiavetta 3.2x6.5 UNI 6606	Clavette 3.2x6.5 UNI 6606	Key 3.2x6.5 UNI 6606	Keil 3.2x6.5 UNI 6606	1
13	ACO2/R	Albero conico	Arbre	Female	Antriebsw	1



SERIE: 25404-4/25604-4

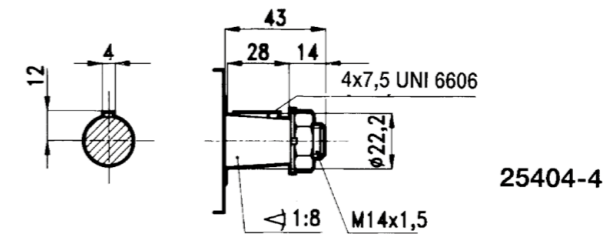
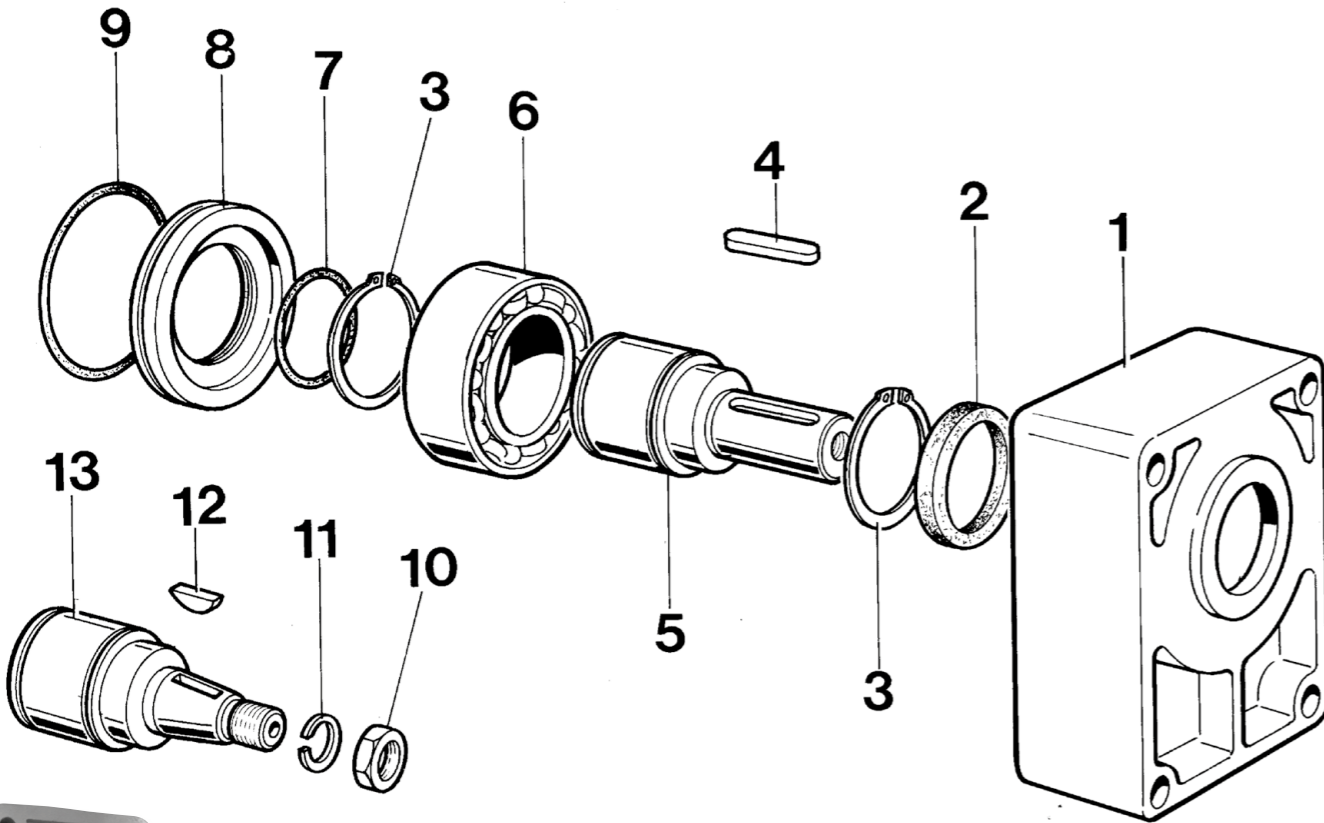

25404-4

315 daN.  
240 daN.

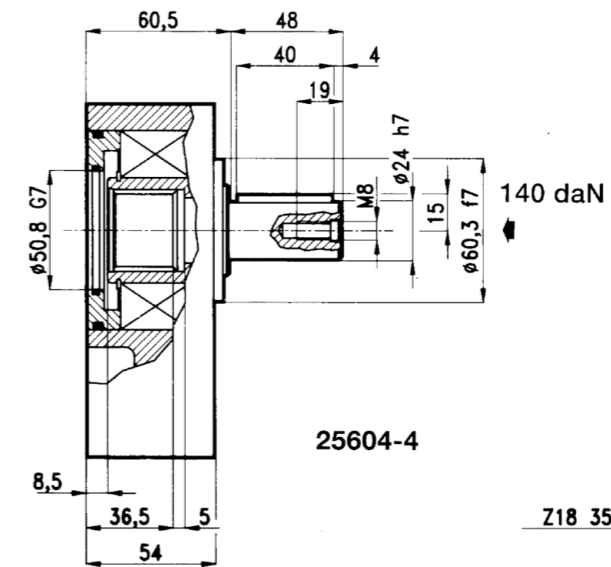
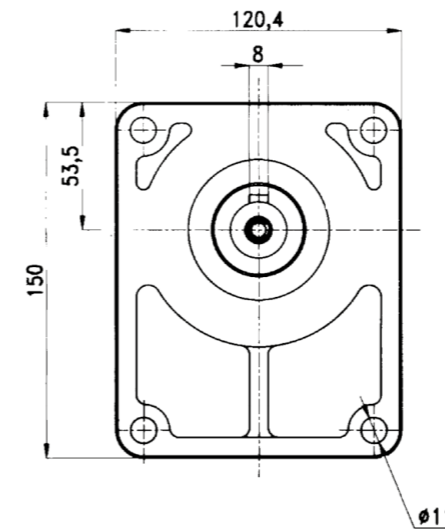

25604-4

Z18 35x31 DIN5482

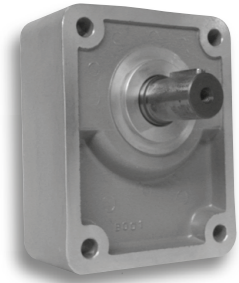

Pos.	CODICE	DENOMINAZIONE	DENOMINATION	DESCRIPTION	BEZEICHNUNG	Q.TA'
1	25004/4.1	Scatola	Carcasse	Housing	Gehäuse	1
2	303852	Anello di tenuta 38x52x7	Bague d'étanchéité 38x52x7	Sealing Ring 38x52x7	Dichtring 38x52x7	1
3	904500	Anello seeger UNI 7435 - 45	Circlip UNI 7435 - 45	Snap ring UNI 7435 - 45	Seegerring UNI 7435 - 45	2
4	428740	Chiavetta 8x7x40 UNI 6604	Clavette 8x7x40 UNI 6604	Key 8x7x40 UNI 6604	Keil 8x7x40 UNI 6604	1
5	AC24/4	Albero D=24	Arbre d=24	Female d=24	Antriedsw d=24	1
6	503209	Cuscinetto 3209A	Palier 3209A	Bearing 3209A	Kugellager 3209A	1
7	403200	Anello OR 3200	Bague torique 3200	O-Ring 3200	O-Ring 3200	1
8	COP085	Anello d=85	Bague d=85	Ring d=85	Ring d=85	1
9	404300	Anello OR 4300	Bague torique OR4300	O-Ring 4300	O-Ring 4300	1
10	601415	Dado UNI 28675 M14X1.5	Ecrous UNI 28675 M14x1.5	Nut UNI 28675 M14x1.5	Mutter UNI 28675 M14x1.5	1
11	801400	Rondella Grower d.14	Rondelle Grower d.14	Wascher Grower d.14	Rosette Grower d.14	1
12	700475	Chiavetta 4x7.5 UNI 6606	Clavette 4x7.5 UNI 6606	Key 4x7.5 UNI 6606	Keil 4x7.5 UNI 6606	1
13	ACO3/4F	Albero conico	Arbre	Female	Antriedsw	1

SERIE: 25404-6/25604-6

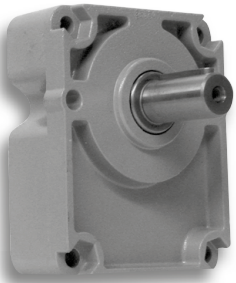
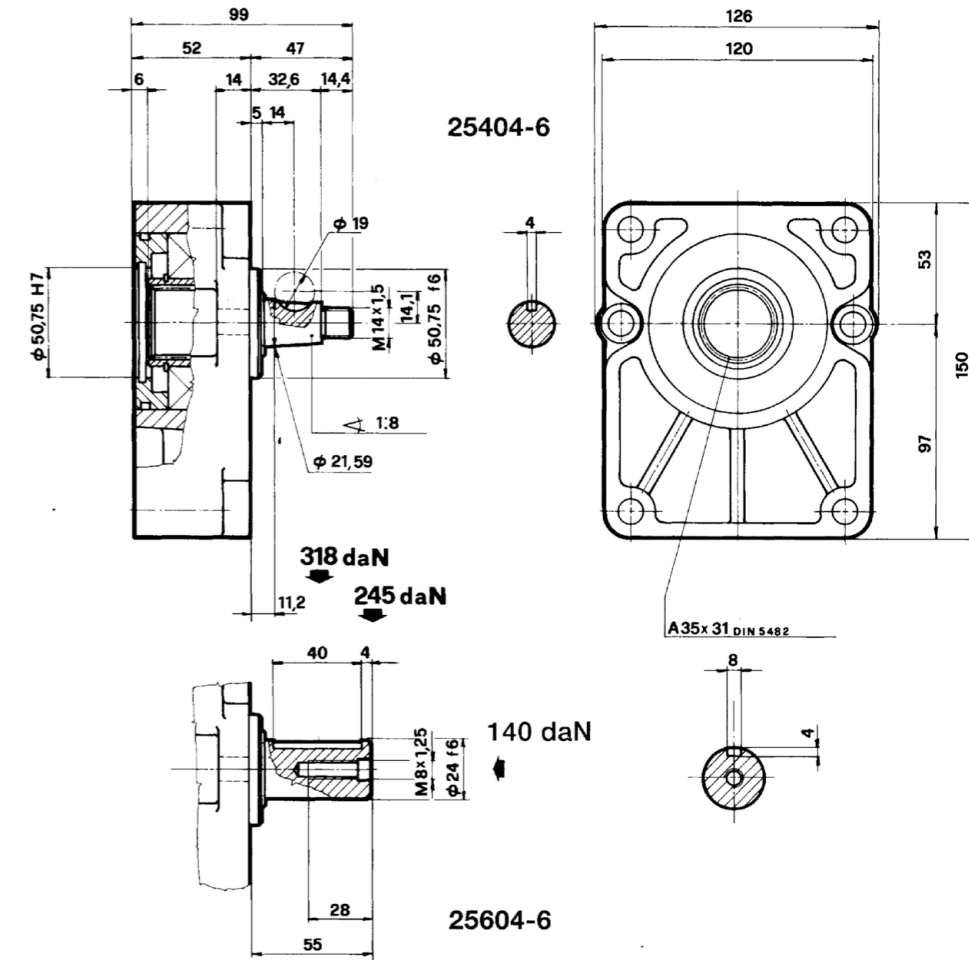
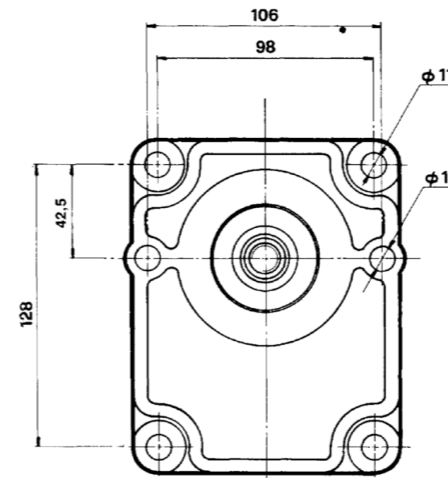
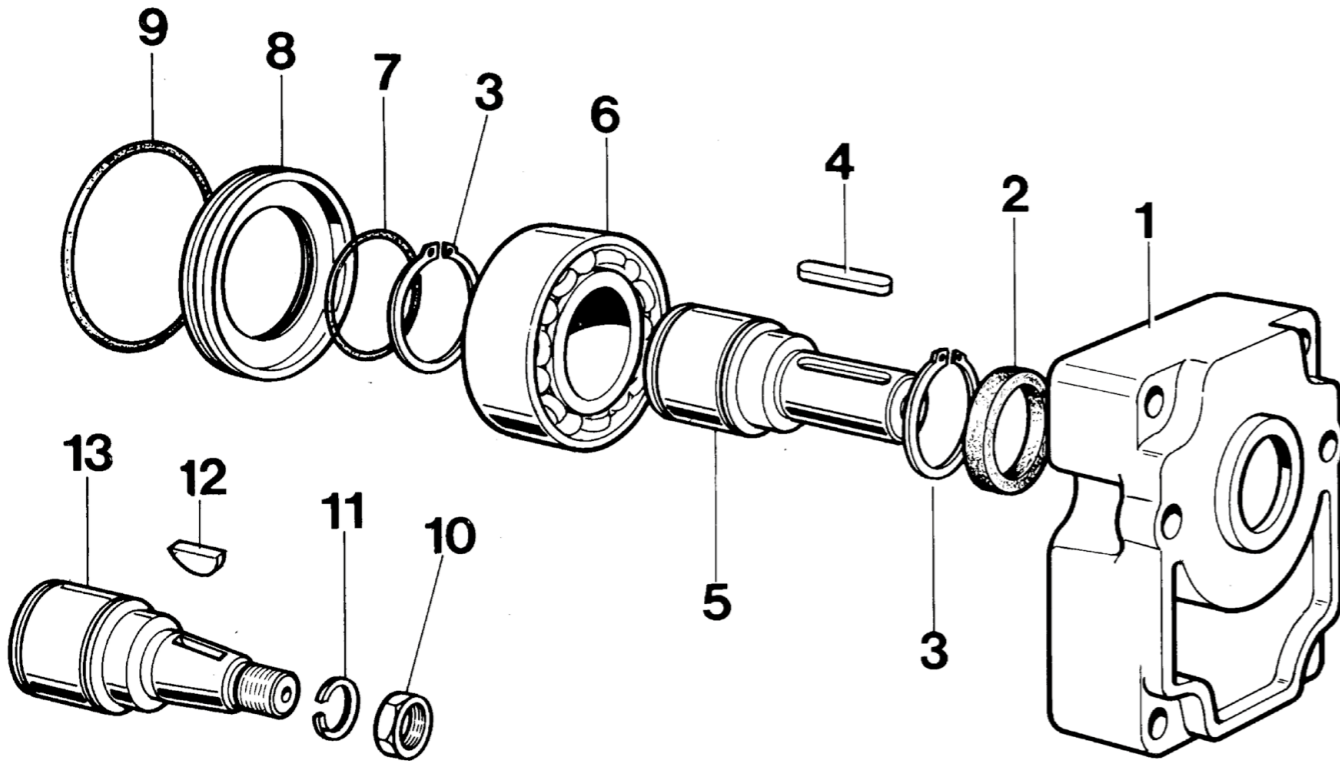

Pos.	CODICE	DENOMINAZIONE	DENOMINATION	DESCRIPTION	BEZEICHNUNG	Q.TA'
1	25004/6.1	Scatola	Carcasse	Housing	Gehäuse	1
2	303545	Anello di tenuta 35x45x7	Bague d'étanchéité 35x45x7	Sealing Ring 35x45x7	Dichtring 35x45x7	1
3	904000	Anello seeger UNI 7435 - 40	Circlip UNI 7435 - 40	Snap ring UNI 7435 - 40	Seegerring UNI 7435 - 40	2
4	428740	Chiavetta 8x7x40 UNI 6604	Clavette 8x7x40 UNI 6604	Key 8x7x40 UNI 6604	Keil 8x7x40 UNI 6604	1
5	AC24	Albero D=24	Arbre d=24	Female d=24	Antriebsw d=24	1
6	503208	Cuscinetto 3208A	Palier 3208A	Bearing 3208A	Kugellager 3208A	1
7	403200	Anello OR 3200	Bague torique 3200	O-Ring 3200	O-Ring 3200	1
8	25003/C.1	Anello d=80	Bague d=80	Ring d=80	Ring d=80	1
9	401740	Anello OR 174	Bague torique OR174	O-Ring 174	O-Ring 174	1
10	601415	Dado UNI 28675 M14X1.5	Ecrous UNI 28675 M14x1.5	Nut UNI 28675 M14x1.5	Mutter UNI 28675 M14x1.5	1
11	801400	Rondella Grower d.14	Rondelle Grower d.14	Wascher Grower d.14	Rosette Grower d.14	1
12	700475	Chiavetta 4x7.5 UNI 6606	Clavette 4x7.5 UNI 6606	Key 4x7.5 UNI 6606	Keil 4x7.5 UNI 6606	1
13	ACO3/6F	Albero conico	Arbre	Female	Antriebsw	1

- SUPPORTO POMPE Gr. 3 / SAE A
- SUPPORT POUR POMPE Gr. 3 / SAE A
- PUMP SUPPORT - GROUP 3 / SAE A
- PUMPENHALTERUNG MIT KEGELWELLE GR 3 / SAE A

- SUPPORTO POMPE Gr. 3 / SAE A
- SUPPORT POUR POMPE Gr. 3 / SAE A
- PUMP SUPPORT - GROUP 3 / SAE A
- PUMPENHALTERUNG MIT KEGELWELLE GR 3 / SAE A

SERIE: 25607

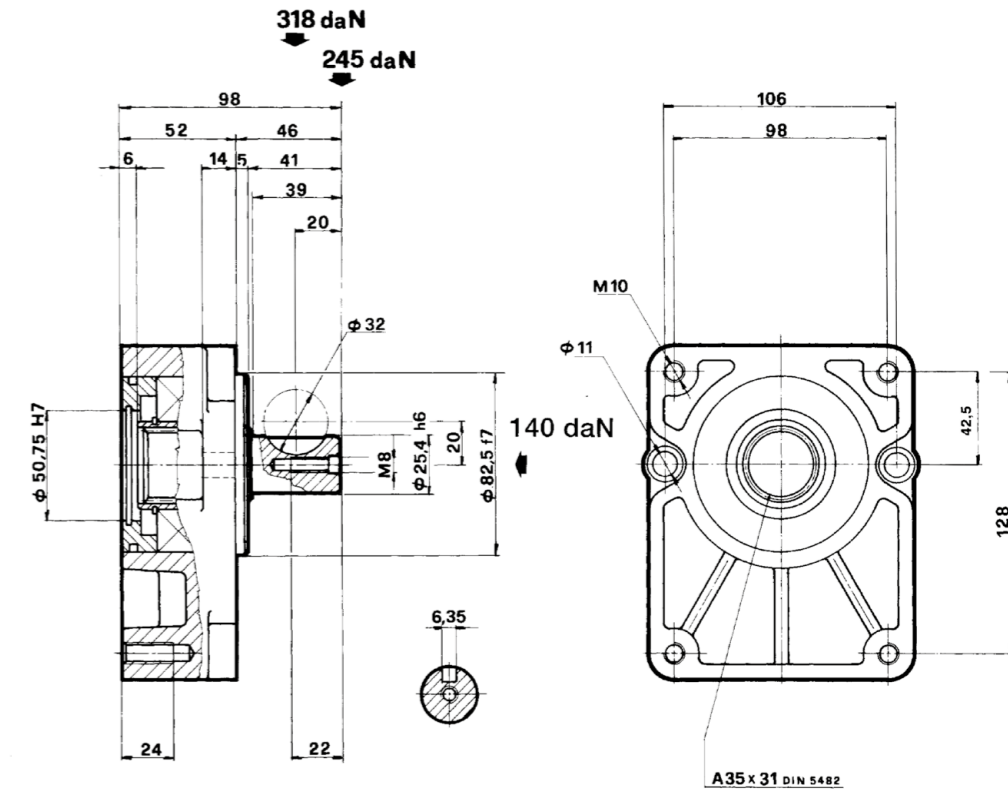
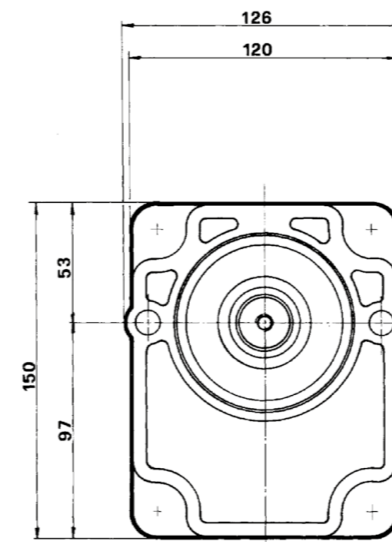
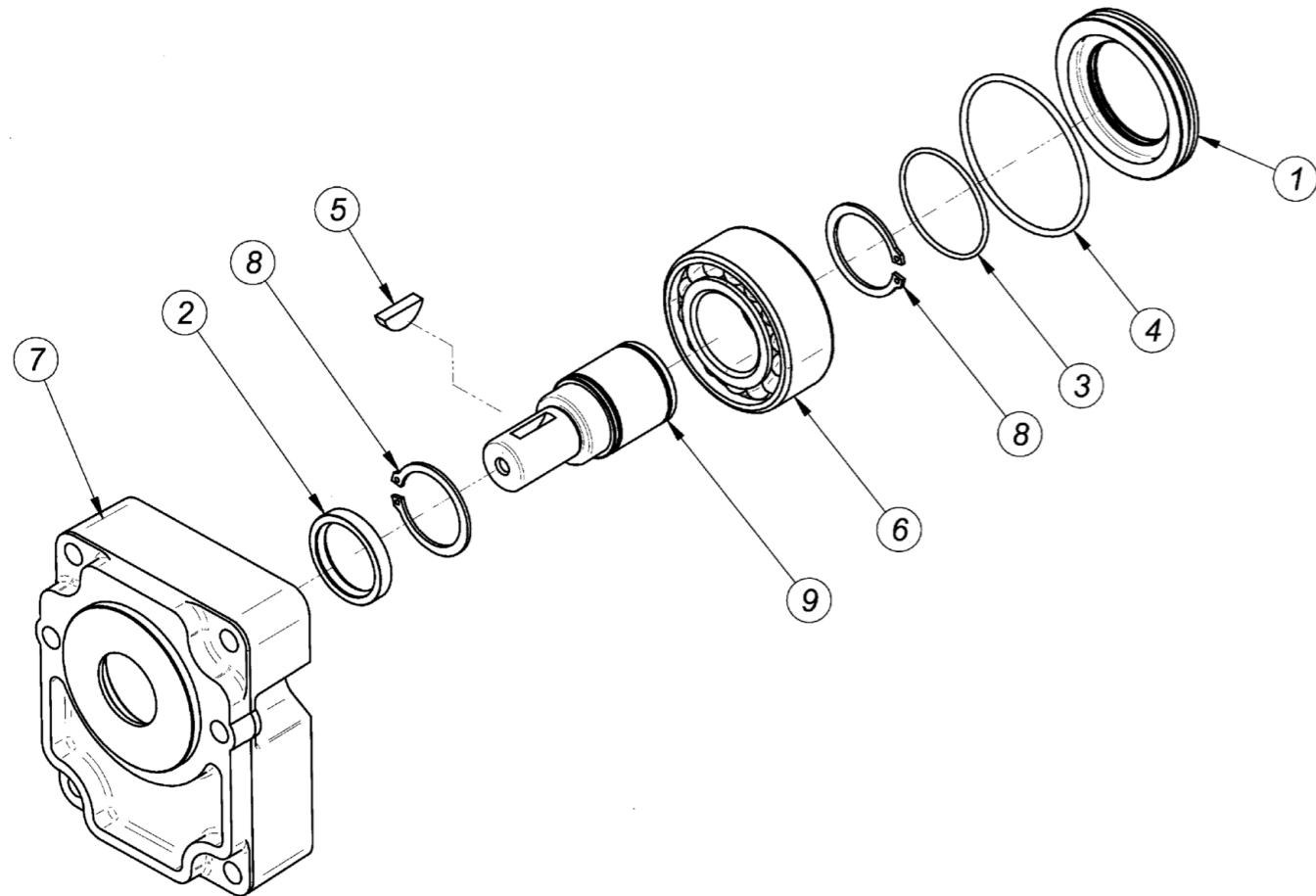

25607

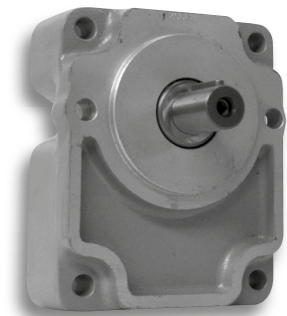

Pos.	CODICE	DENOMINAZIONE	DENOMINATION	DESCRIPTION	BEZEICHNUNG	Q.TA'
1	25003/C.1	Anello	Bague	Ring	Ring	1
2	303545	Anello di tenuta 35x45x7	Bague d'etancheite 35x45x7	Sealing ring 35x45x7	Dichtring 35x45x7	1
3	403200	Anello OR	Bague torique	O-Ring	O-Ring	1
4	401740	Anello OR	Bague toriqu	O-Ring	O-Ring	1
5	700610	Chiavetta 6x10 UNI 6606	Clavette 6x10 UNI 6606	Key 6x10 UNI 6606	Keil 6x10 UNI 6606	1
6	503208	Cuscinetto 3208A	Palier 3208A	Bearing 3208A	Kugellager 3208A	1
7	25007.1	Scatola	Carcasse	Housing	Gehäuse	1
8	904000	Anello seeger UNI 7435 - 40	Circlip UNI 7435 - 40	Snap ring UNI 7435 - 40	Seegerring UNI 7435 - 40	2
9	AC 25.4	Albero d.40	Arbre d.40	Female d.40	Antriebsw d.40	1





- SUPPORTO CON FLANGIA SAE B 2 FORI PER POMPE Gr. 3
- SUPPORT AVEC BRIDE SAE B 2 TROUS POUR POMPES Gr. 3
- SUPPORT WITH FLANGE SAE B, 2-HOLE, FOR PUMPS GROUP 3
  - PUMPENHALTERUNG MIT FLANSCH SAE B, 2 BOHRUNGEN FÜR PUMPEN GR 3



- SUPPORTO CON FLANGIA SAE B 2 FORI PER POMPE Gr. 3
- SUPPORT AVEC BRIDE SAE B 2 TROUS POUR POMPES Gr. 3
- SUPPORT WITH FLANGE SAE B, 2-HOLE, FOR PUMPS GROUP 3
  - PUMPENHALTERUNG MIT FLANSCH SAE B, 2 BOHRUNGEN FÜR PUMPEN GR 3

SERIE: 25608

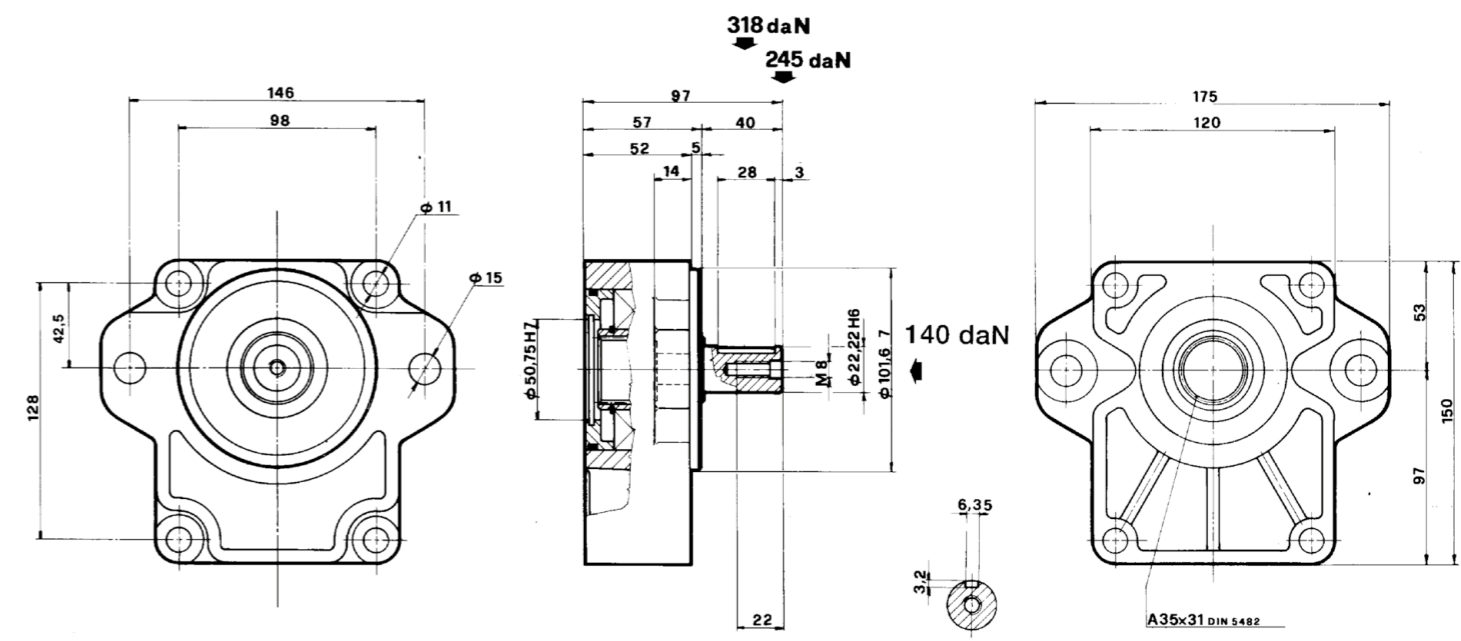
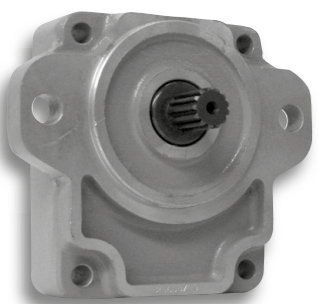
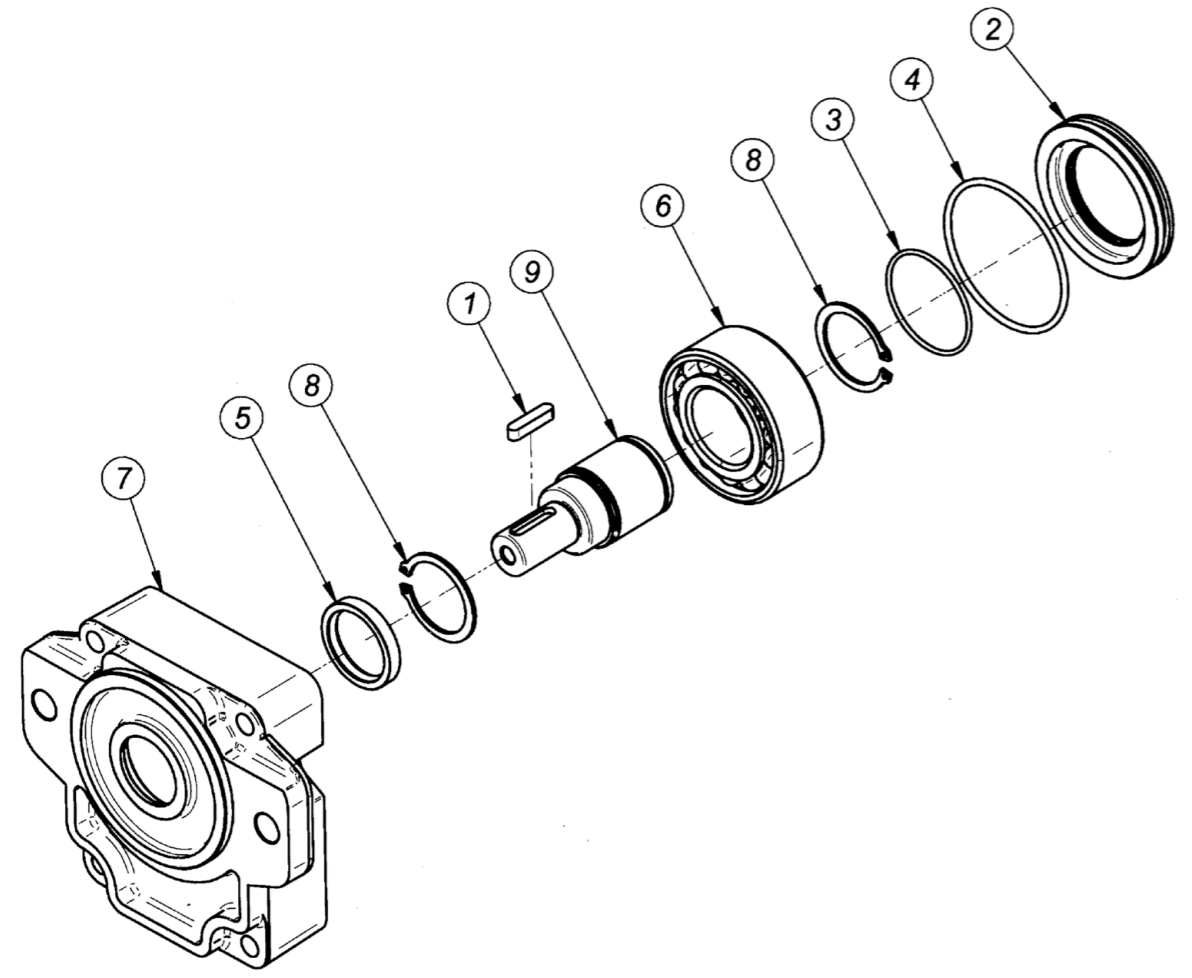

25608

Pos.	CODICE	DENOMINAZIONE	DENOMINATION	DESCRIPTION	BEZEICHNUNG	Q.TA'
1	426628	Chiavetta 6x6x28 UNI 6604	Clavette 6x6x28 UNI 6604	Key 6x6x28 UNI 6604	Keil 6x6x28 UNI 6604	1
2	25003/C.1	Anello	Bague	Ring	Ring	1
3	403200	Anello OR	Bague torique	O-Ring	O-Ring	1
4	401740	Anello OR	Bague toriquir	O-Ring	O-Ring	1
5	303545	Anello di tenuta 35x45x7	Bague d'etancheite 35x45x7	Sealing ring 35x45x7	Dichtring 35x45x7	1
6	503208	Cuscinetto 3208A	Palier 3208A	Bearing 3208A	Kugellager 3208A	1
7	25008.1	Scatola	Carcasse	Housing	Gehäuse	1
8	904000	Anello seeger UNI 7435 - 40	Circlip UNI 7435 - 40	Snap ring UNI 7435 - 40	Seegerring UNI 7435 - 40	2
9	AC 22.2	Albero d.22.2	Arbre d.22.2	Female d.22.2	Antriebsw d.22.2	1



SERIE: 25405/25605

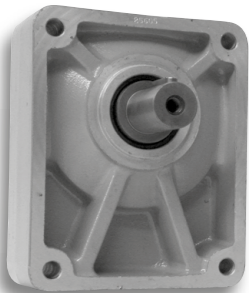
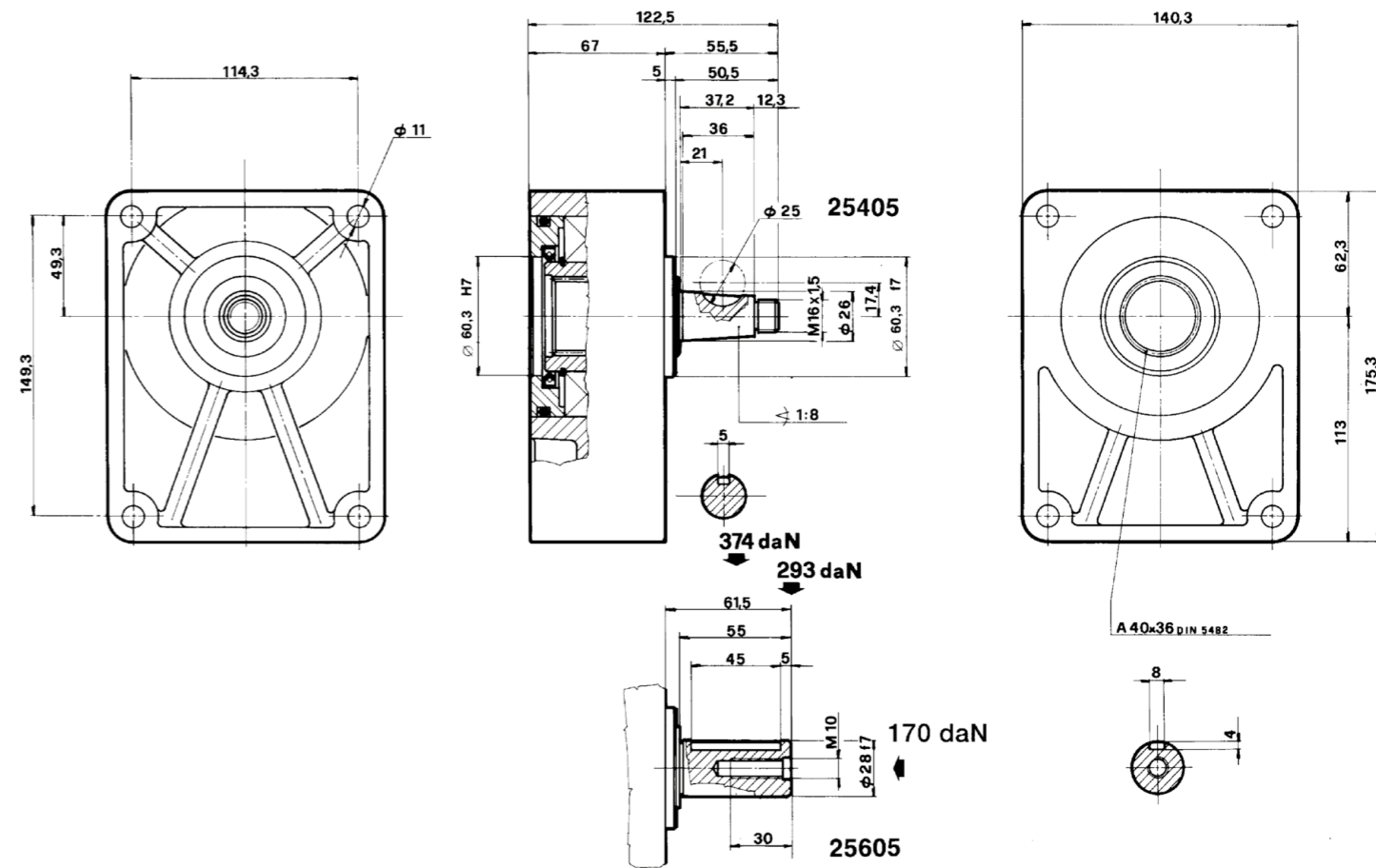
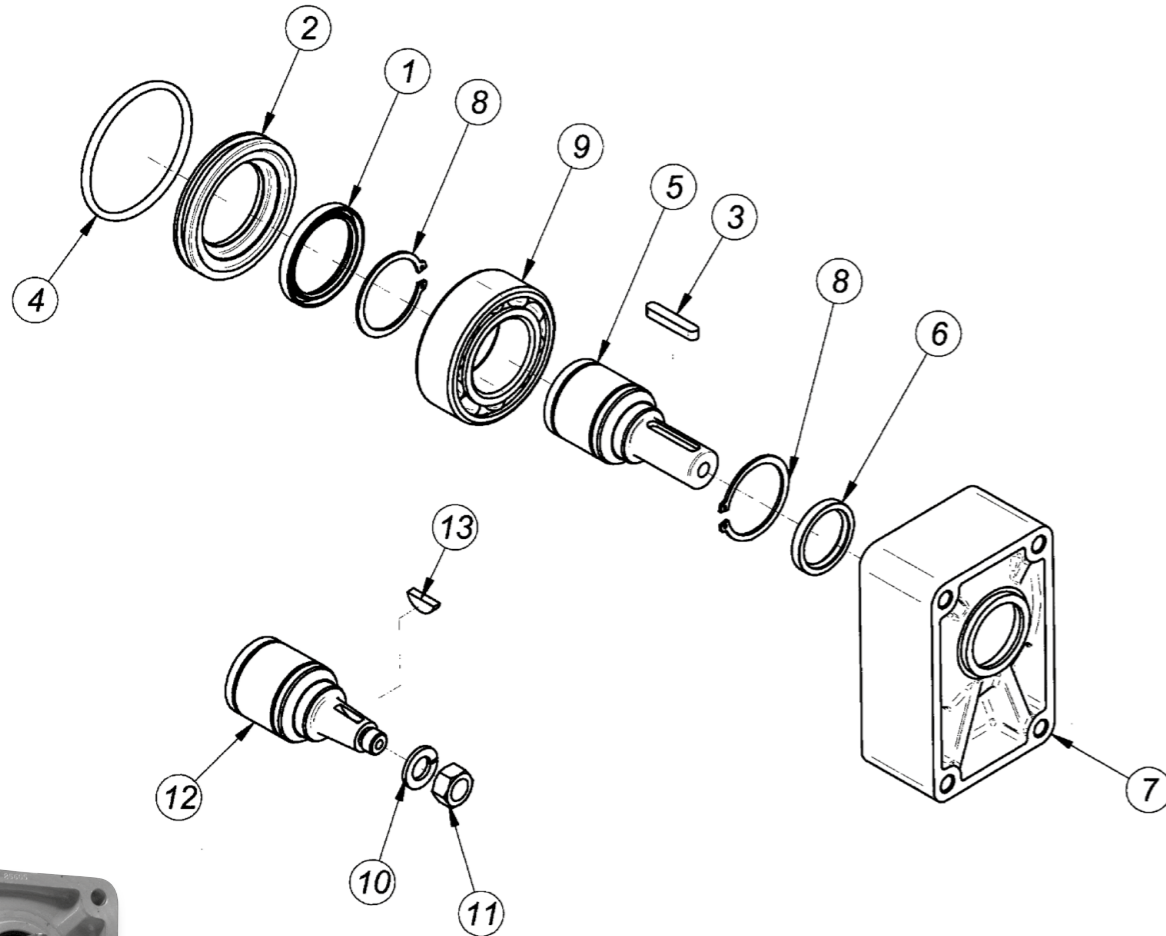

Pos.	CODICE	DENOMINAZIONE	DENOMINATION	DESCRIPTION	BEZEICHNUNG	Q.TA'
1	305572	Anello di tenuta 55x72x8	Bague d'étanchéité 55x72x8	Sealing ring 55x72x8	Dichtring 55x72x8	1
2	COP100	Anello D=100	Bague D=100	Ring D=100	Ring D=100	1
3	428745	Chiavetta 8x7x45 UNI 6604	Clavette 8x7x45 UNI 6604	Key 8x7x45 UNI 6604	Keil 8x7x45 UNI 6604	1
4	401850	Anello OR 185	Bague torique OR 185	O-Ring 185	O-Ring 185	1
5	AC28	Albero conico	Arbre	Female	Antriebsw	1
6	304052	Anello di tenuta 40x52x7	Bague d'étanchéité 40x52x7	Sealing ring 40x52x7	Dichtring 40x52x7	1
7	25005.1	Scatola	Carcasse	Housing	Gehäuse	1
8	905500	Anello seeger UNI 7435 - 55	Circlip UNI 7435 - 55	Snap ring UNI 7435 - 55	Seegering UNI 7435 - 55	2
9	503211	Cuscinetto 3211	Palier 3211	Bearing 3211	Kugellager 3211	1
10	801600	Rosetta UNI 8839 - B 16	Rondelle UNI 8839 B 16	Washer UNI 8839 B 16	Rosette UNI 8839 B 16	1
11	601615	Dado esagonale normale M16x1,5	Ecrou M16x1.5	Nut M16x1.5	Mutter M16x1.5	1
12	AC03.5	Albero conico	Arbre	Female	Antriebsw	1
13	700510	Chiavetta 5x10 UNI 6606	Clavette 5x10 UNI 6606	Key 5x10 UNI 6606	Keil 5x10 UNI 6606	1

SERIE: 25406/25606

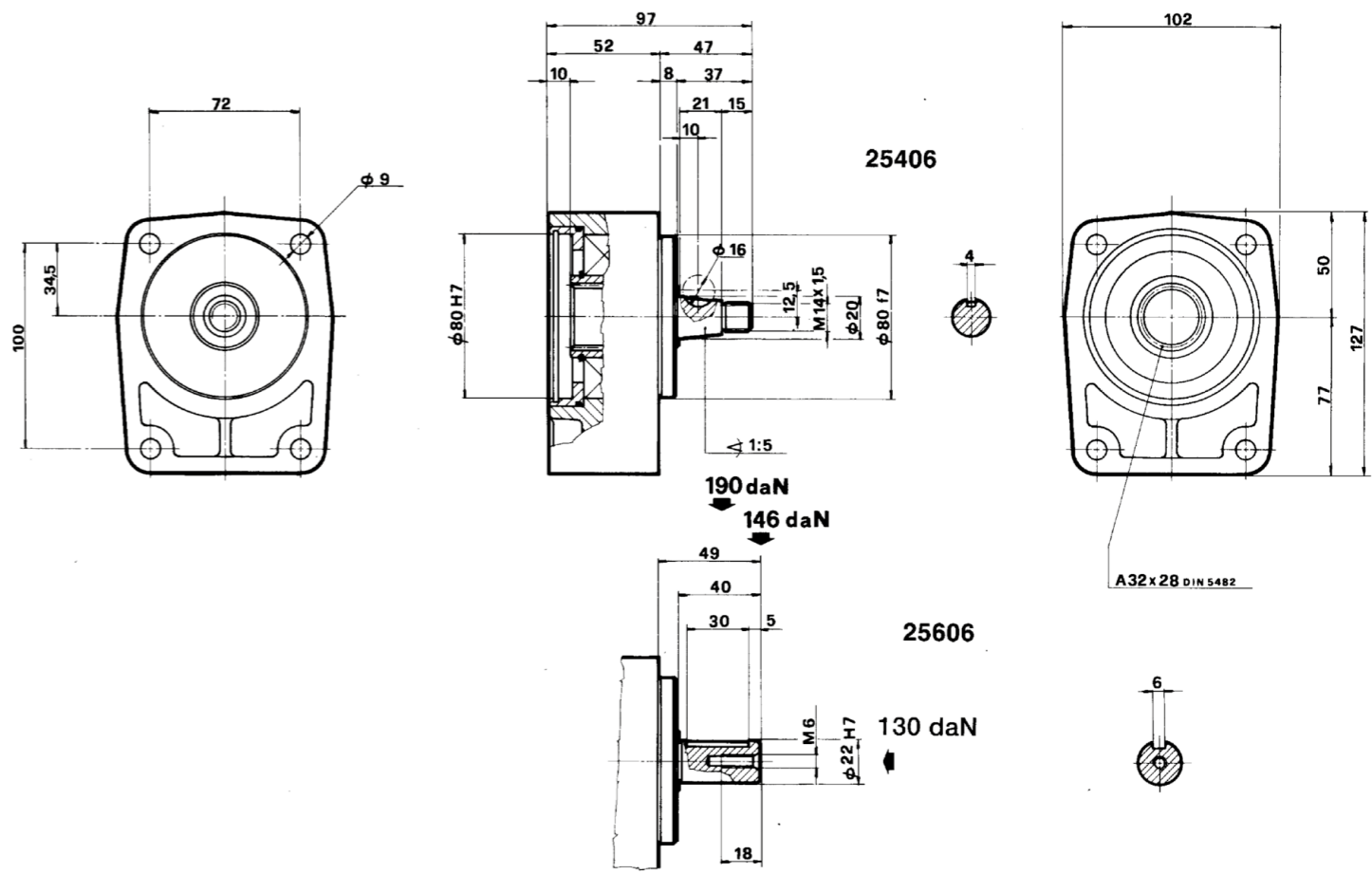
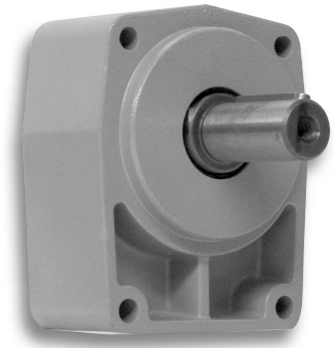
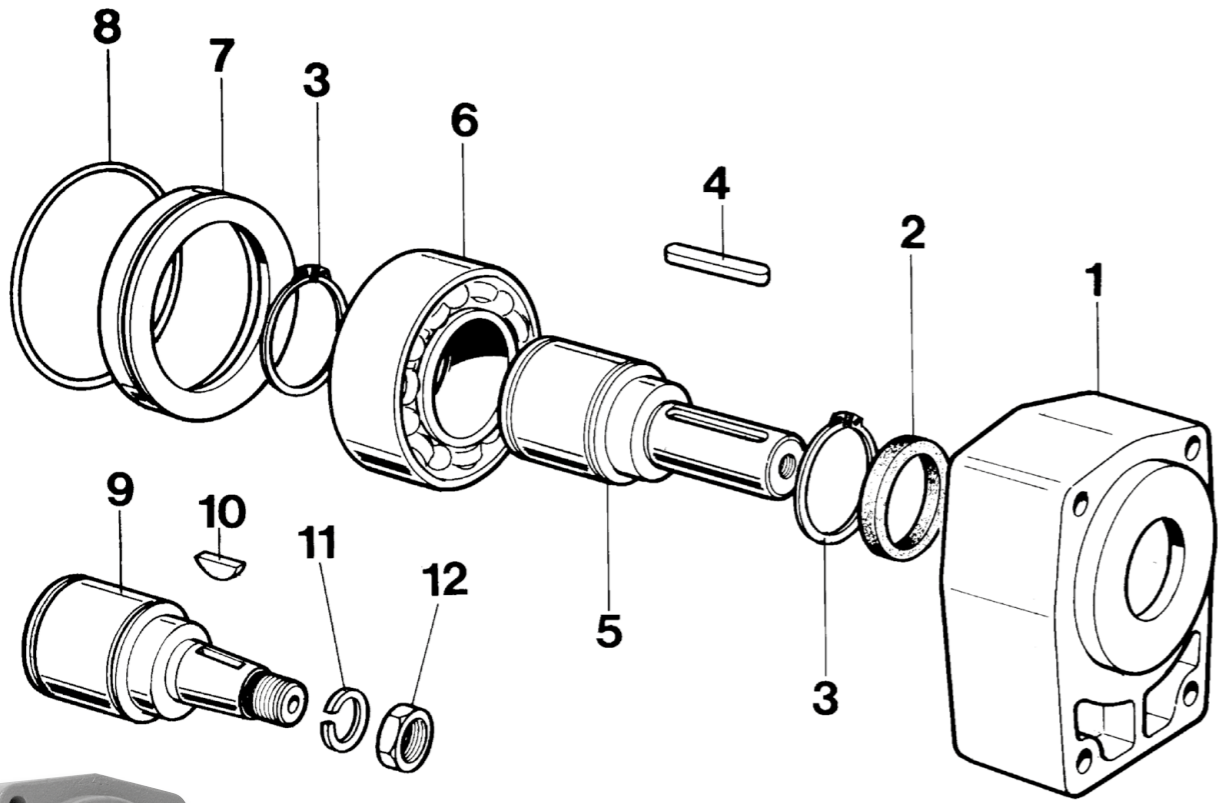

Pos.	CODICE	DENOMINAZIONE	DENOMINATION	DESCRIPTION	BEZEICHNUNG	Q.TA'
1	25006.1	Scatola	Carcasse	Housing	Gehäuse	1
2	303040	Anello di tenuta 30x40x7	Bague d'étanchéité 30x40x7	Sealing Ring 30x40x7	Dichtring 30x40x7	1
3	904000	Anello seeger UNI 7435 - 40	Circlip UNI 7435 - 40	Snap ring UNI 7435 - 40	Seegerring UNI 7435 - 40	2
4	426640	Chiavetta 6x6x40 UNI 6604	Clavette 6x6x40 UNI 6604	Key 6x6x40 UNI 6604	Keil 6x6x40 UNI 6604	1
5	AC22/R	Albero D=22	Arbre d=22	Female d=22	Antriebsw d=22	1
6	503208	Cuscinetto 3208A	Palier 3208A	Bearing 3208A	Kugellager 3208A	1
7	COP088	Anello d=88	Bague d=88	Ring d=88	Ring d=88	1
8	418025	Anello OR 80x2.5	Bague torique 80x2.5	O-Ring 80x2.5	O-Ring 80x2.5	2
9	ACO2/B	Albero conico	Arbre	Female	Antriebsw	1
10	700465	Chiavetta 4x6.5x16 UNI 6606	Clavette 4x6.5x16 UNI 6606	Key 4x6.5x16 UNI 6606	Keil 4x6.5x16 UNI 6606	1
11	801400	Rondella Grower d.14	Rondelle Grower d.14	Wascher Grower d.14	Rosette Grower d.14	1
12	601415	Dado UNI 28675 M14x1.5	Ecrous UNI 28675 M14x1.5	Nut UNI 28675 M14x1.5	Mutter UNI 28675 M14x1.5	1

SERIE: 25407

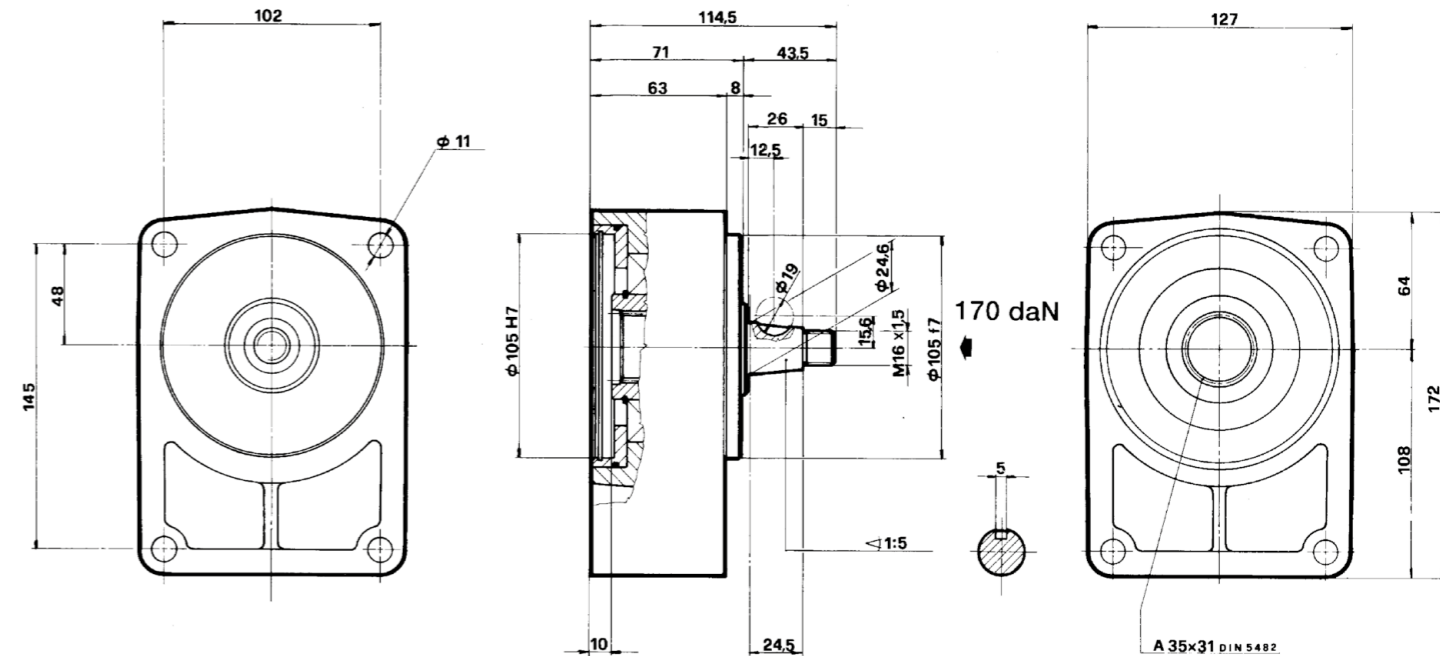
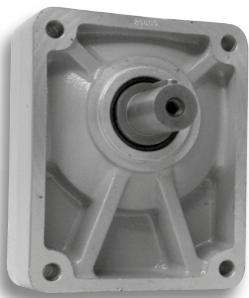
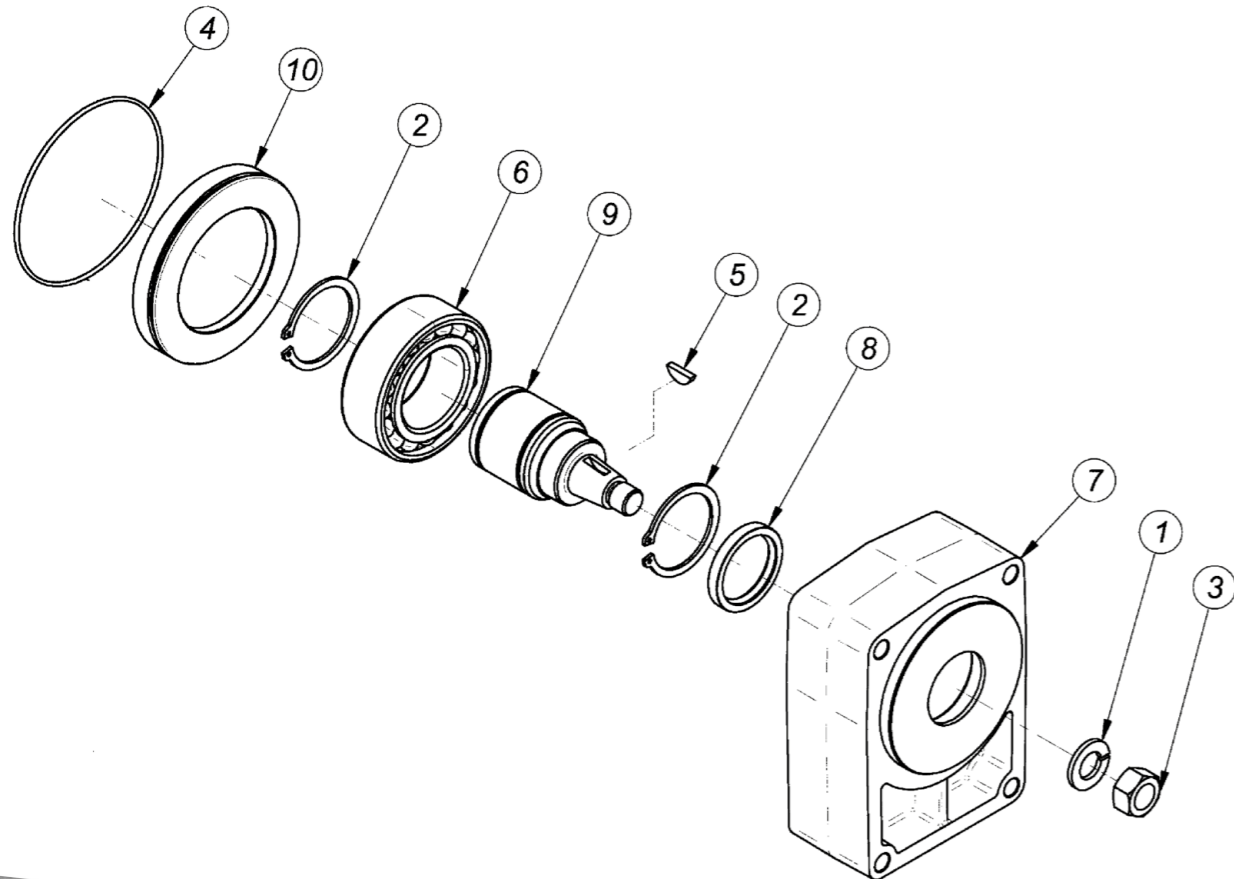

25407

Pos.	CODICE	DENOMINAZIONE	DENOMINATION	DESCRIPTION	BEZEICHNUNG	Q.TA'
1	801600	Rosetta UNI 8839 - B 16	Rondelle UNI 8839 B 16	Washer UNI 8839 B 16	Rosette UNI 8839 B 16	1
2	905000	Anello seeger UNI 7435 - 50	Circlip UNI 7435 - 50	Snap ring UNI 7435 - 50	Seegerring UNI 7435 - 50	2
3	601615	Dado esagonale normale M16x1,5	Ecrou M16x1,5	Nut M16x1,5	Mutter M16x1,5	1
4	401890	Anello OR 189	Bagur torique OR189	O-Ring 189	O-Ring 189	1
5	424751	Chiavetta 4x7.5 UNI 6606	Clavette 4x7.5 UNI 6606	Key 4x7.5 UNI 6606	Keil 4x7.5 UNI 6606	1
6	503210	Cuscinetto 3210 A	Palier 3210 A	Bearing 3210 A	Kugellager 3210 A	1
7	25007.1B	Scatola	Carcasse	Housing	Gehäuse	1
8	304052	Anello di tenuta 40x52x7	Bague d'étanchéité 40x52x7	Sealing ring 40x52x7	Dichtring 40x52x7	1
9	AC03/B50	Albero	Arbre	Female	Antriebsw	1
10	25007/C	Anello	Bague	Ring	Ring	1



SERIE: 25408

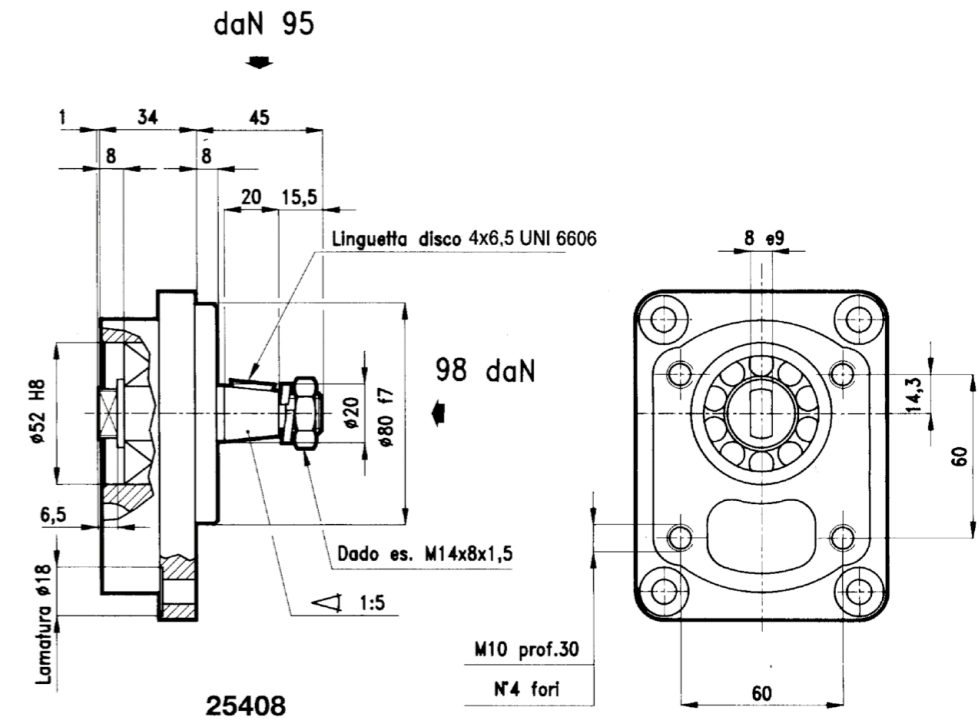
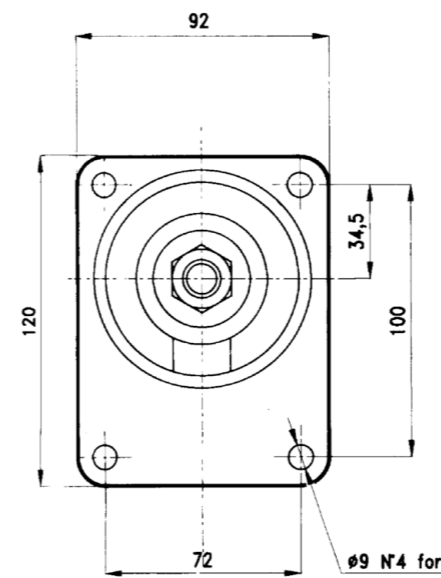
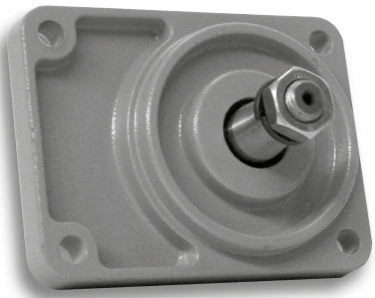
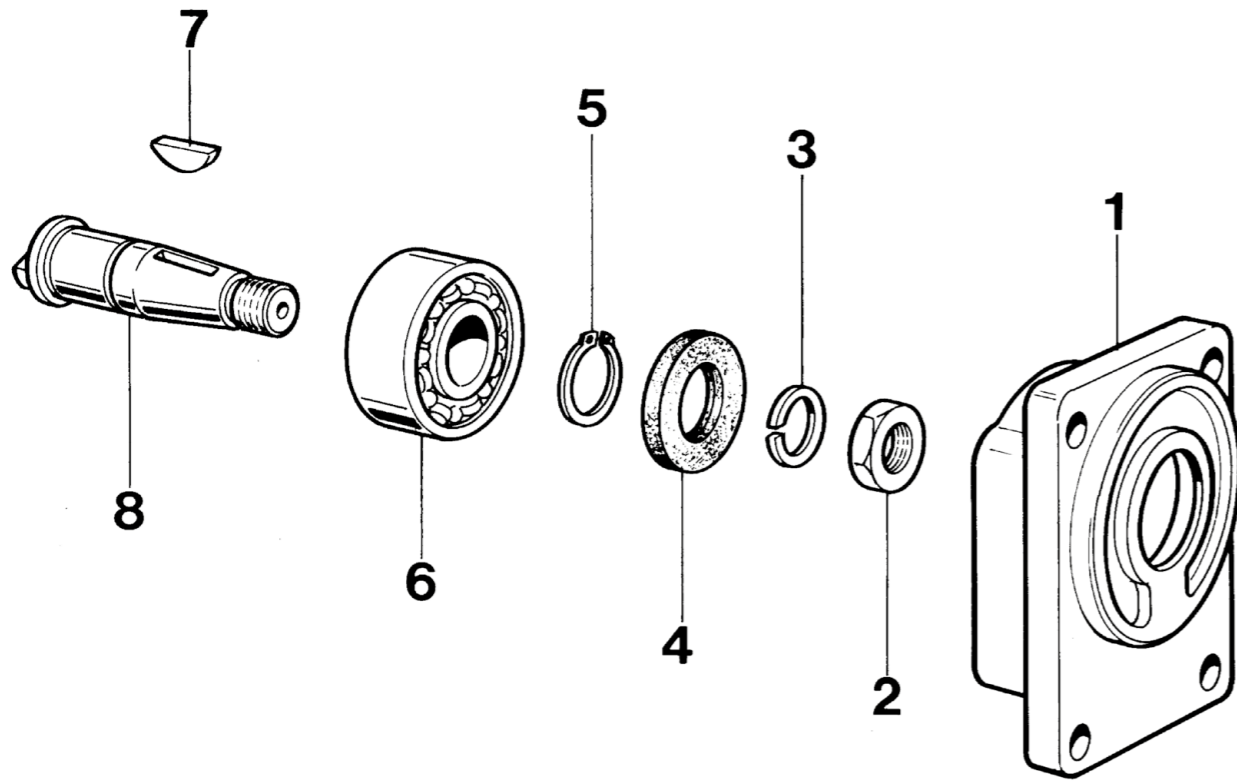

25408

Pos.	CODICE	DENOMINAZIONE	DENOMINATION	DESCRIPTION	BEZEICHNUNG	Q.TA'
1	25006.2	Scatola	Carcasse	Housing	Gehäuse	1
2	601415	Dado UNI 28675 M14X1.5	Ecrous UNI 28675 M14x1.5	Nut UNI 28675 M14x1.5	Mutter UNI 28675 M14x1.5	1
3	801400	Rondella Grower d.14	Rondelle Grower d.14	Wascher Grower d.14	Rosette Grower d.14	1
4	302040	Anello di tenuta 20x40x7	Bague d'étanchéité 20x40x7	Sealing Ring 20x40x7	Dichtring 20x40x7	1
5	902000	Anello seeger UNI 7435 - 20	Circlip UNI 7435 - 20	Snap ring UNI 7435 - 20	Seegerring UNI 7435 - 20	1
6	503304	Cuscinetto 3304 A	Palier 3304 A	Bearing 3304 A	Kugellager 3304 A	1
7	700465	Chiavetta 4x6.5x16 UNI 6606	Clavette 4x6.5x16 UNI 6606	Key 4x6.5x16 UNI 6606	Keil 4x6.5x16 UNI 6606	1
8	ACO2/S	Albero	Arbre	Female	Antriedsw	1



SERIE: 25409

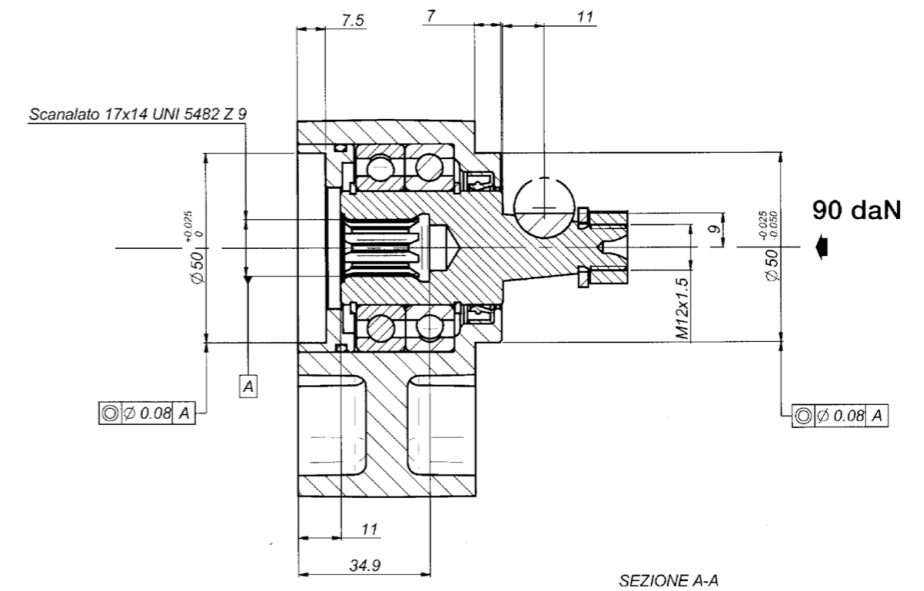
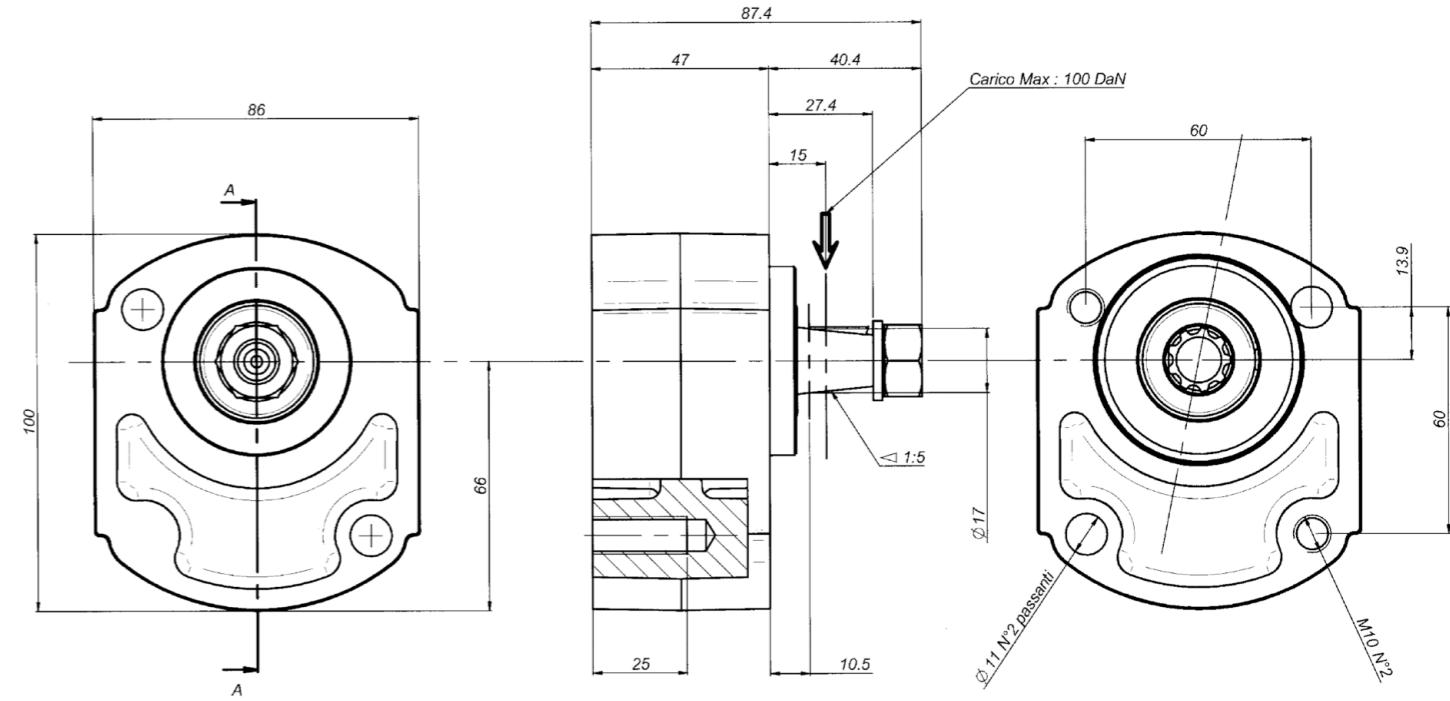
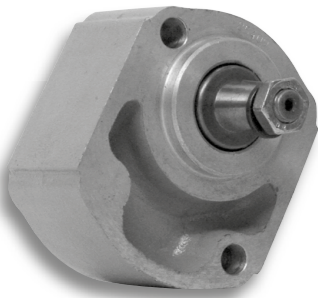
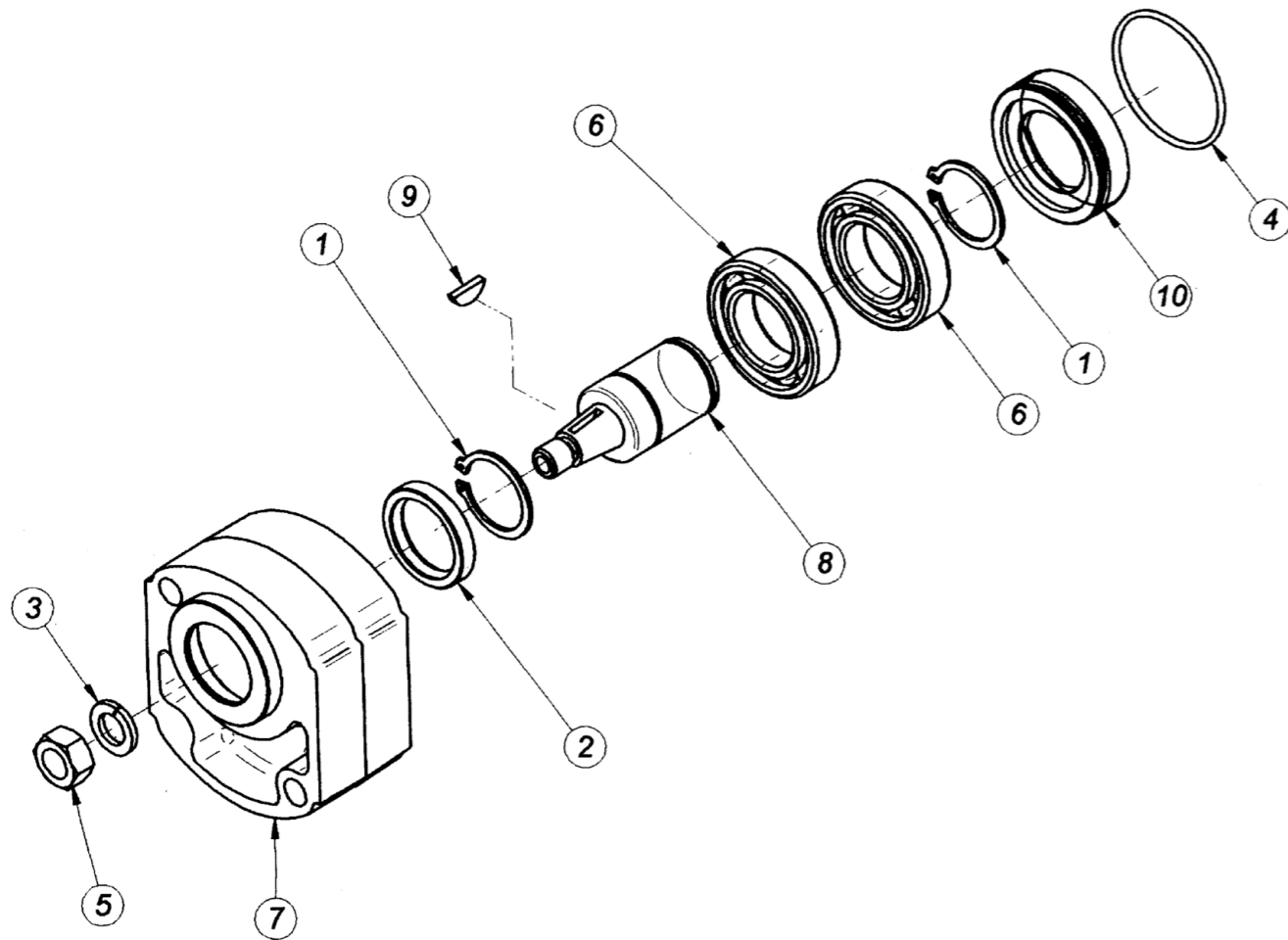

25409

Pos.	CODICE	DENOMINAZIONE	DENOMINATION	DESCRIPTION	BEZEICHNUNG	Q.TA'
1	903000	Anello seeger UNI 7435 - 30	Circlip UNI 7435 - 30	Snap ring UNI 7435 - 30	Seegering UNI 7435 - 30	2
2	303040	Anello di tenuta 30x40x7	Bague d'etancheite 30x40x7	Sealing ring 30x40x7	Dichtring , durchm. 30x40x7	1
3	801200	Rosetta d.12.5	Rondelle d.12.5	Washer d.12.5	Rosette d.12.5	1
4	403200	Anello OR	Bague torique	O-ring	O-ring	1
5	601215	Dado M12	Ecrous M12	Nut M12	Mutter M12	1
6	506006	Cuscinetto 6006	Palier 6006	Bearing 6006	Kugellager 6006	2
7	25006.3	Scatola	Carcasse	Housing	Gehäuse	1
8	AC02/1714	Albero	Arbre	Female	Antriebsw	1
9	700365	Chiavetta 3x6.5	Clavette 3x6.5	Key 3x6.5	Keil 3x6.5	1
10	COPO55	Anello	Bague	Ring	Ring	1

SERIE: 25609

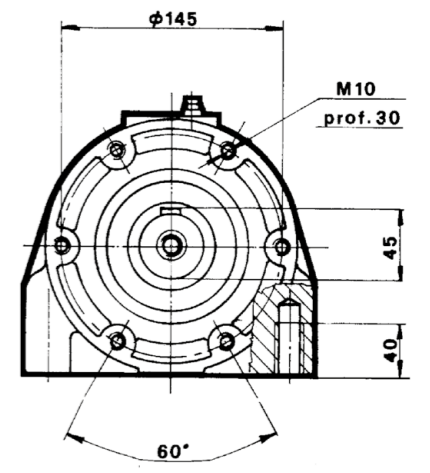
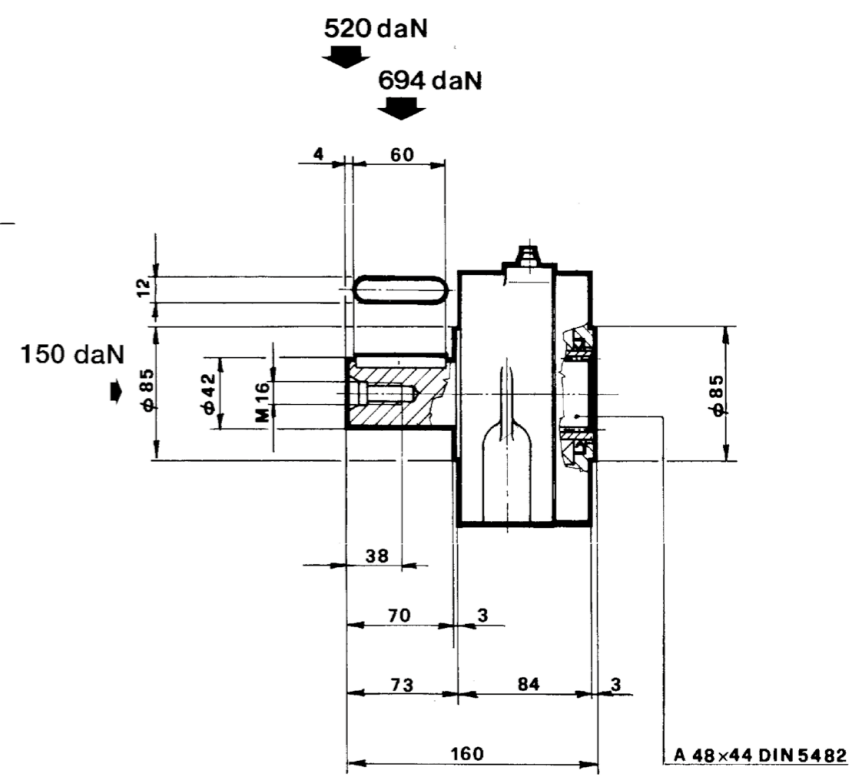
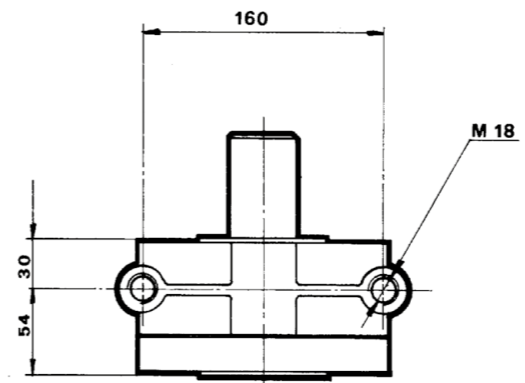
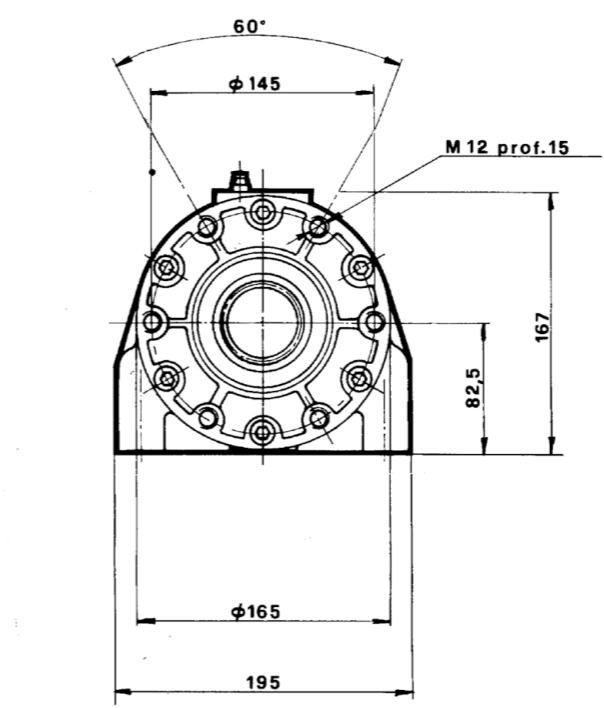
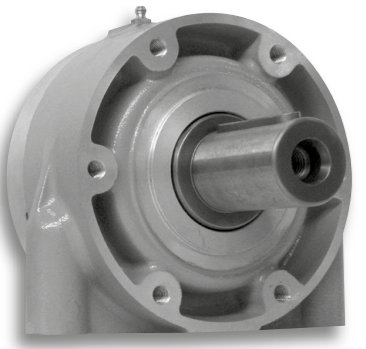
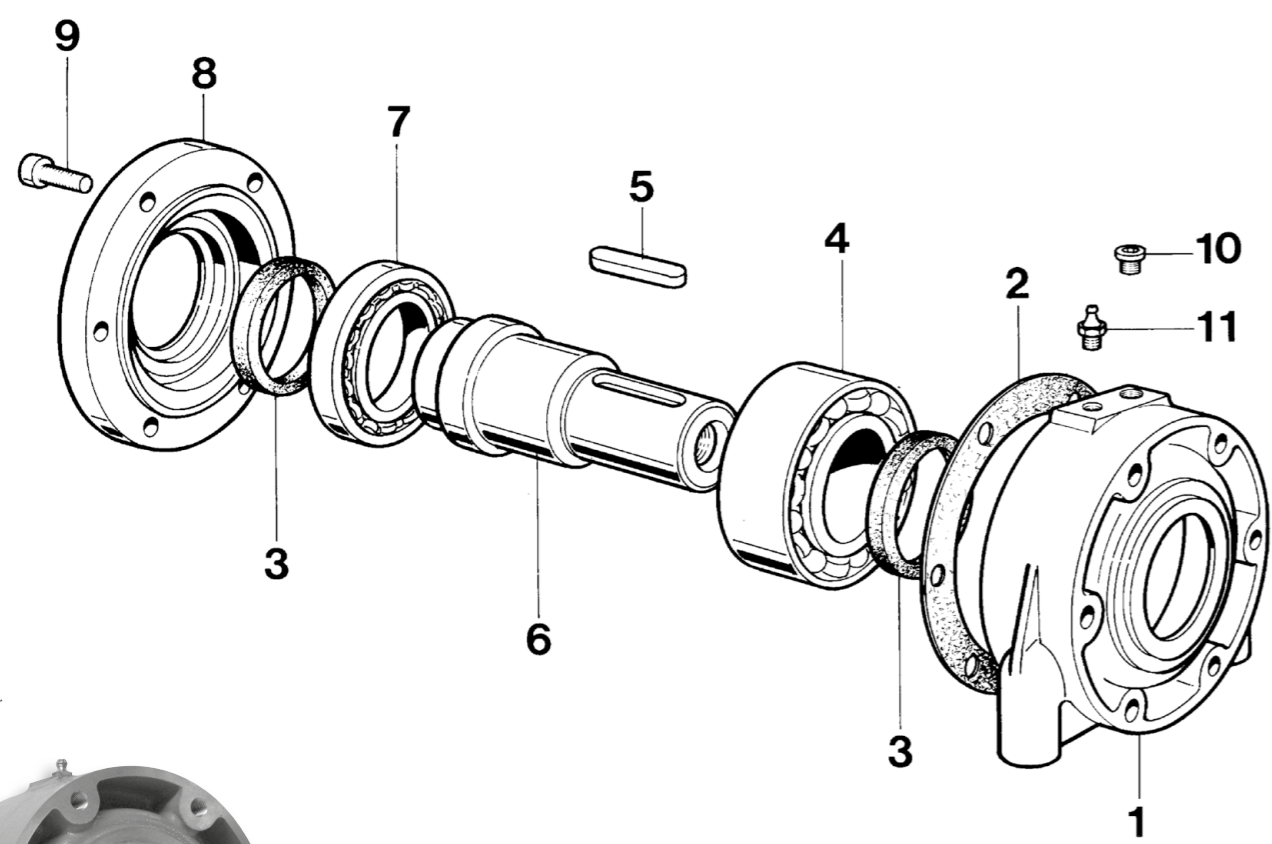

Pos.	CODICE	DENOMINAZIONE	DENOMINATION	DESCRIPTION	BEZEICHNUNG	Q.TA'
1	25009.1	Scatola	Carcasse	Housing	Gehäuse	1
2	30470.2	Guarnizione	Joint	Gasket	Dichtung	1
3	306075	Anello di tenuta 60x75x8	Bague d'étanchéité 60x75x8	Sealing Ring 60x75x8	Dichtring 60x75x8	2
4	503212/Z	Cuscinetto 3212 A	Palier 3212 A	Bearing 3212 A	Kugellager 3212 A	1
5	421286	Chiavetta 12x8x60 UNI 6604	Clavette 12x8x60 UNI 6604	Key 12x8x60 UNI 6604	Keil 12x8x60 UNI 6604	1
6	AC 42	Albero D=42	Arbre d=42	Female d=42	Antriedsw d=42	1
7	501601	Cuscinetto 16012 A	Palier 16012 A	Bearing 16012 A	Kugellager 16012 A	1
8	30470	Flangia	Bride	Flange	Flansch	1
9	611025	Vite TCEI M10x25	Vis TCHC M10x25	Socket Capscrew M10x25	Zylinderkopfschraube mit Innensechskant M10x25	6
10	940182	Tappo scarico olio 1/8" G	Bouchon vidange huile 1/8" G	Oil drain plug 1/8" G	Ölablaßschraube 1/8" G	1
11	500000.1	Ingrassatore UNI 7663-A M8x1.25	Graisseur UNI 7663-A M8x1.25	Grease nipple UNI 7663-A M8x1.25	Fettbuchse UNI 7663-A M8x1.25	1

25609





- SUPPORTO IN GHISA POMPE Gr. 3
- SUPPORT EN FONTE POUR POMPE Gr. 3
- CAST IRON PUMP SUPPORT Gr. 3
- GUSSPUMPENHALTERUNG MIT KEGELWELLE Gr. 3



- SUPPORTO IN GHISA POMPE Gr. 3
- SUPPORT EN FONTE POUR POMPE Gr. 3
- CAST IRON PUMP SUPPORT Gr. 3
- GUSSPUMPENHALTERUNG MIT KEGELWELLE Gr. 3

SERIE: 25610/24

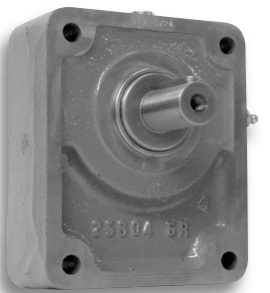
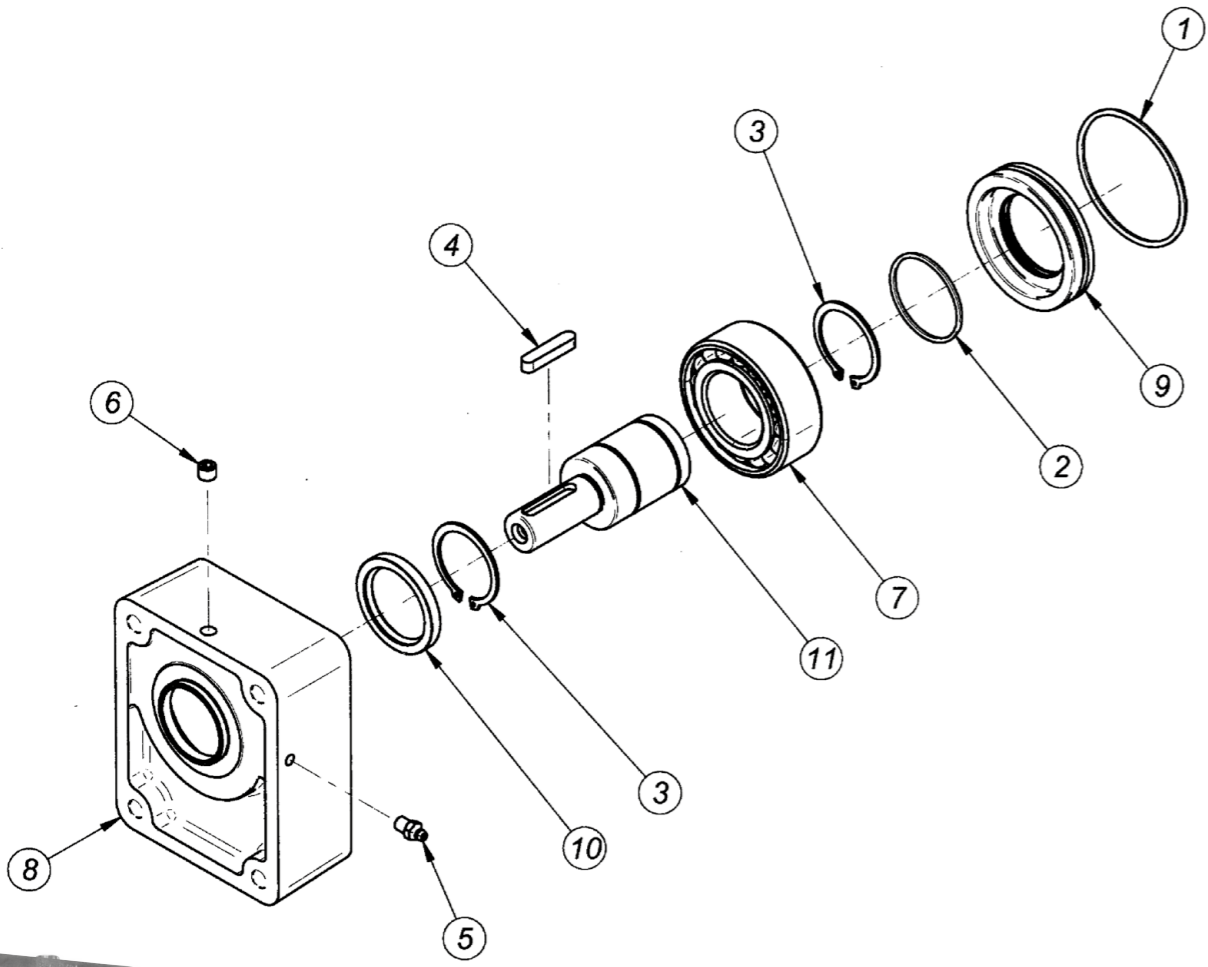

Pos.	CODICE	DENOMINAZIONE	DENOMINATION	DESCRIPTION	BEZEICHNUNG	Q.TA'
1	404300	Anello OR	Bague torique	O-Ring	O-Ring	1
2	403200	Anello OR 3200	Bague torique 3200	O-Ring 3200	O-Ring 3200	1
3	904500	Anello elastico d.45	Circlip d.45	Snap ring d.45	Seegerring d.45	2
4	428740	Chiavetta 8x7x40	Clavette 8x7x40	Key 8x7x40	Keil 8x7x40	1
5	500000.1	Ingrassatore M8	Engraisseur M8	Fattener M8	Fattener M8	1
6	940182	Tappo M10x1	Bouchon M10x1	Oil drain M10x1	Olablabschraube M10x1	1
7	503209	Cuscinetto 3209 A	Palier 3209 A	Bearing 3209 A	Kugellager 3209 A	1
8	28000.1	Scatola	Carcasse	Housing	Gehäuse	1
9	COPO85	Anello	Bague	Ring	Ring	1
10	304560	Anello di tenuta 45x60x7	Bague d' étanchéité 45x60x7	Sealing ring 45x60x7	Dichtring 45x60x7	1
11	AC24/G	Albero d.24	Arbre d.24	Female d.24	Antriebsw d.24	1

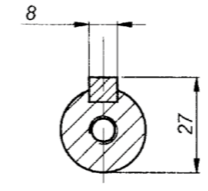
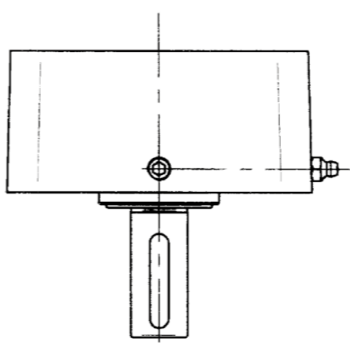
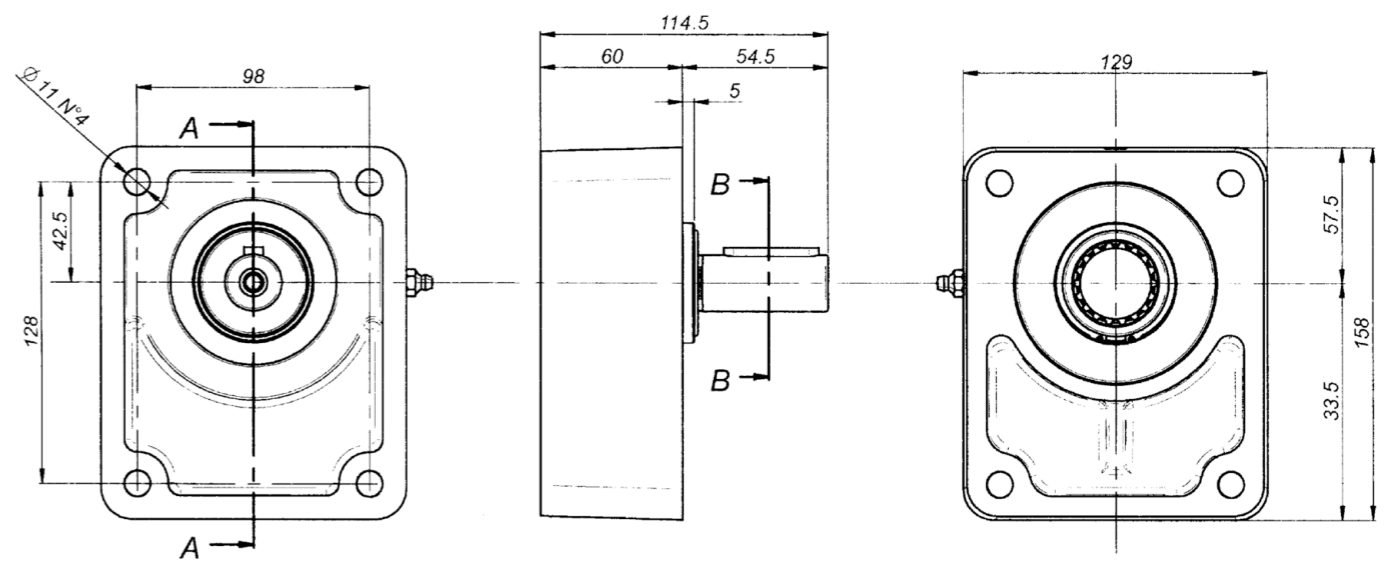

SEZ.: B-B  
1:2

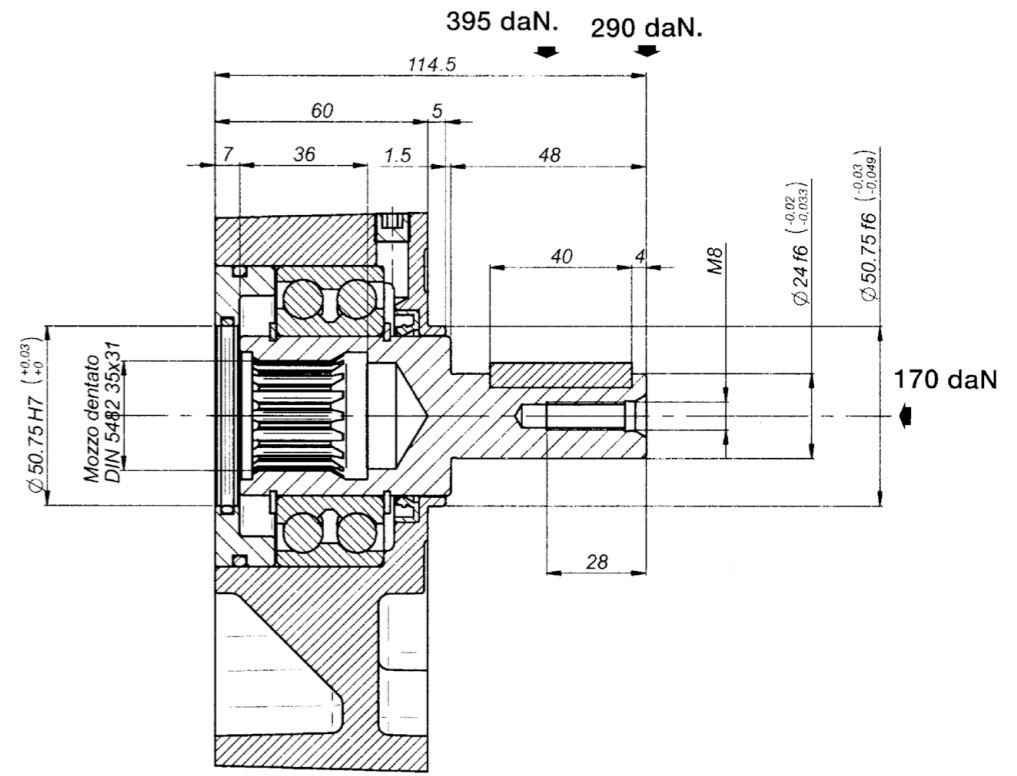

25610/24

SEZ.: A-A  
1:2

- SUPPORTO IN GHISA POMPE Gr. 3
- SUPPORT EN FONTE POUR POMPE Gr. 3
- CAST IRON PUMP SUPPORT Gr. 3
- GUSSPUMPENHALTERUNG MIT KEGELWELLE Gr. 3

- SUPPORTO IN GHISA POMPE Gr. 3
- SUPPORT EN FONTE POUR POMPE Gr. 3
- CAST IRON PUMP SUPPORT Gr. 3
- GUSSPUMPENHALTERUNG MIT KEGELWELLE Gr. 3

SERIE: 25610/40

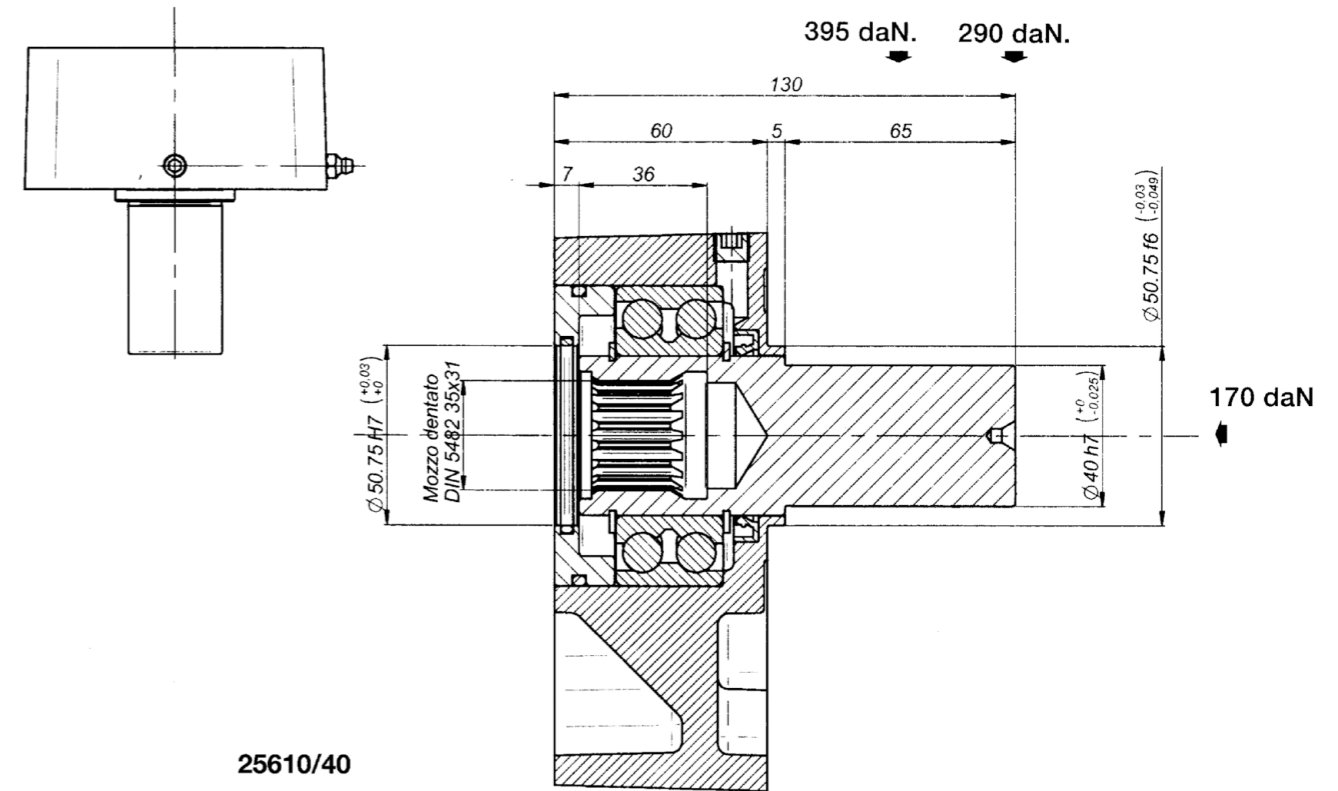
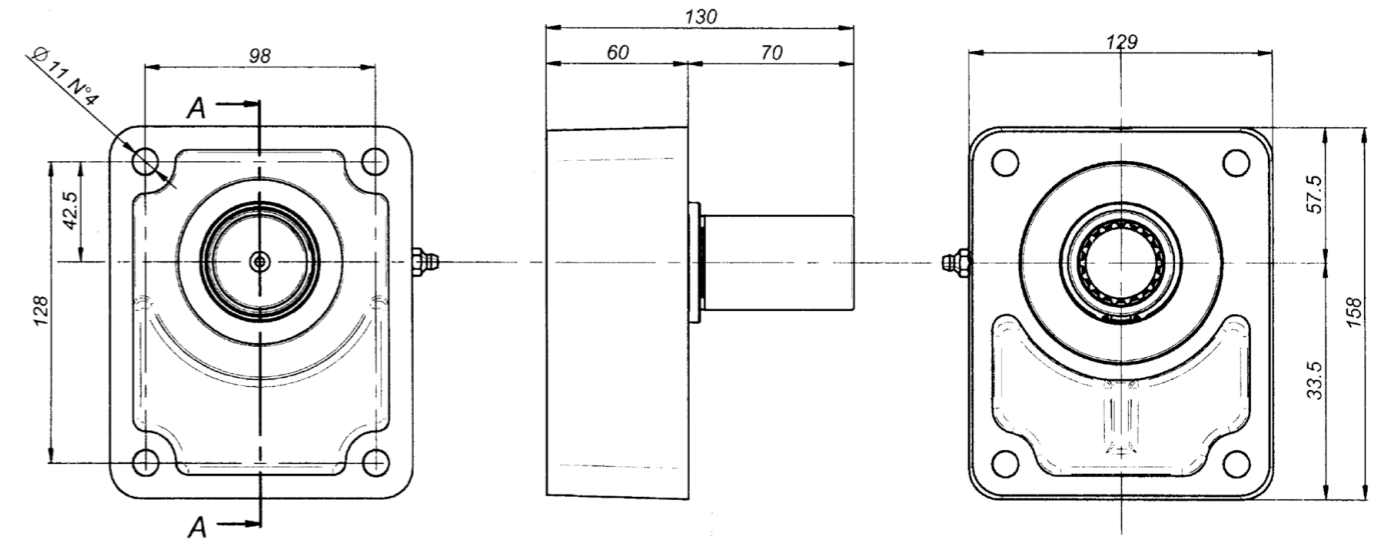
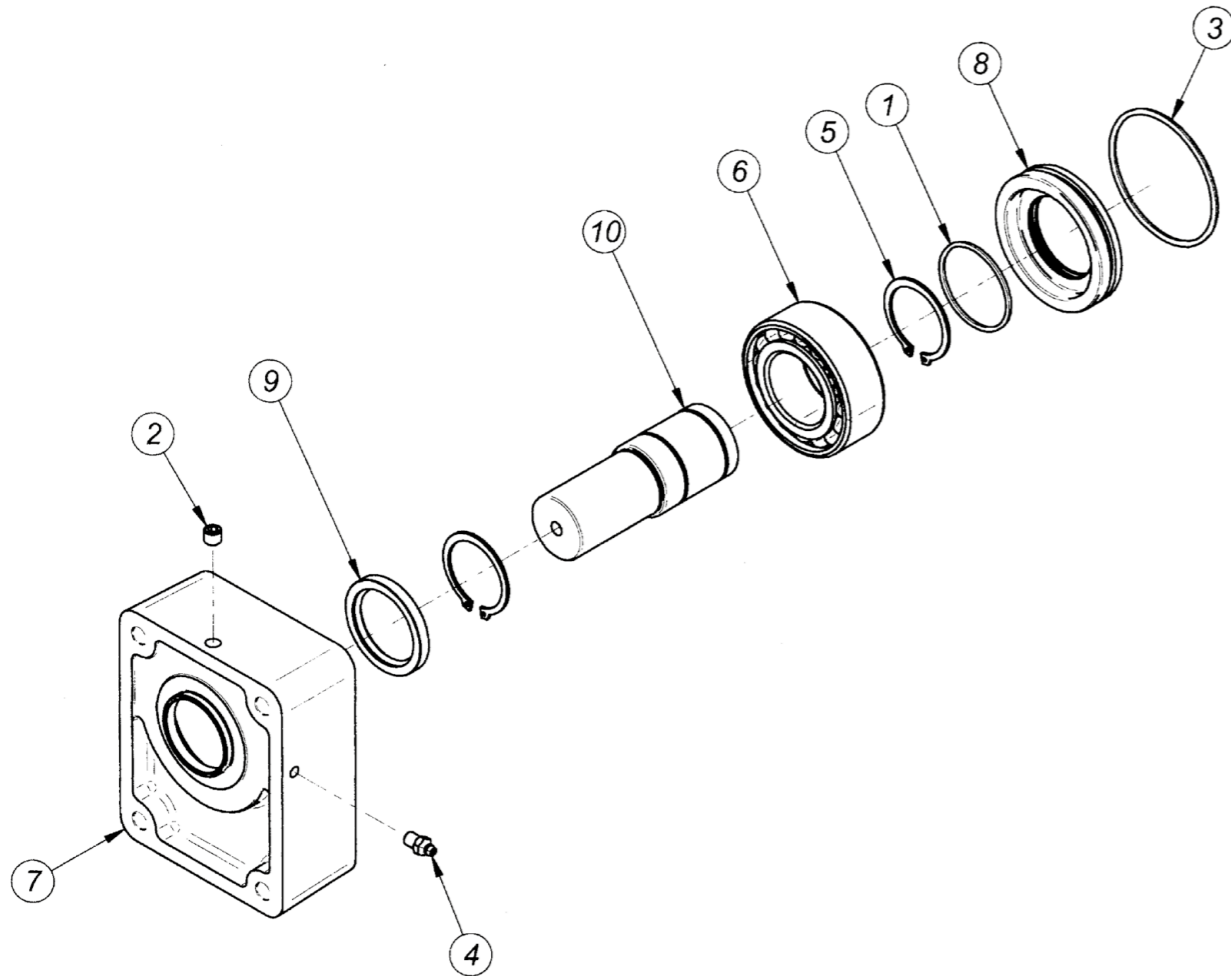

25610/40

SEZIONE A-A

Pos.	CODICE	DENOMINAZIONE	DENOMINATION	DESCRIPTION	BEZEICHNUNG	Q. TA'
1	403200	Anello OR 3200	Bague torique 3200	O-Ring 3200	O-Ring 3200	1
2	940182	Tappo M10x1	Bouchon M10x1	Oil drain M10x1	Olablabschraube M10x1	1
3	404300	Anello OR	Bague torique	O-Ring	O-Ring	1
4	500000.1	Ingrassatore M8	Engraisseur M8	Fattener M8	Fattener M8	1
5	904500	Anello elastico d.45	Circlip d.45	Snap ring d.45	Seegerring d.45	2
6	503209	Cuscinetto 3209 A	Palier 3209 A	Bearing 3209 A	Kugellager 3209 A	1
7	28000.1	Scatola	Carcasse	Housing	Gehäuse	1
8	COPO85	Anello	Bague	Ring	Ring	1
9	304560	Anello di tenuta 45x60x7	Bague d'étanchéité 45x60x7	Sealing ring 45x60x7	Dichtring 45x60x7	1
10	AC40	Albero d.40	Arbre d.40	Female d.40	Antriebsw d.40	1



- FLANGIE PER SUPPORTI POMPE Gr. 4 UNIVERSALE
- BRIDES POUR SUPPORTS POUR POMPES Gr. 4
- FLANGES FOR PUMP SUPPORTS GROUP 4
- FLANSCH FÜR PUMPENHALTERUNGEN GR 4

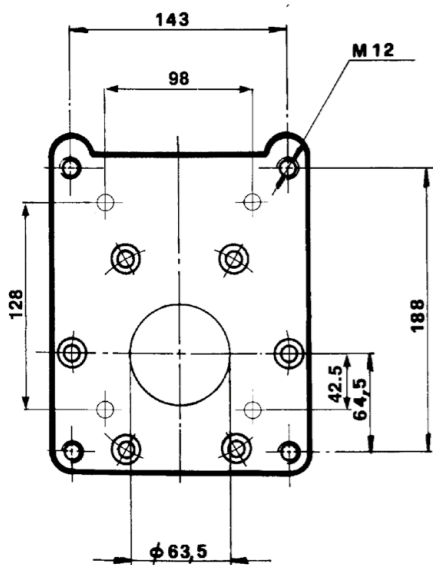

4 P 30403  
3 P 30401

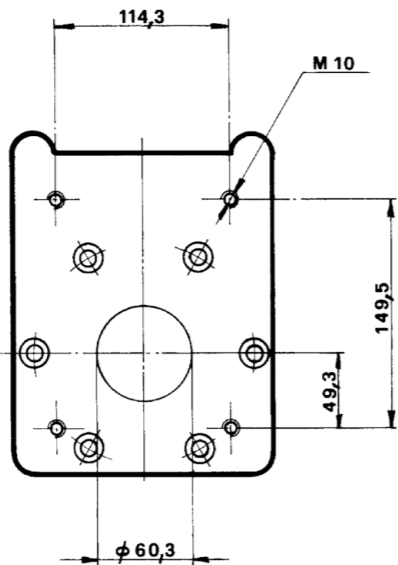

3,5 P 30402

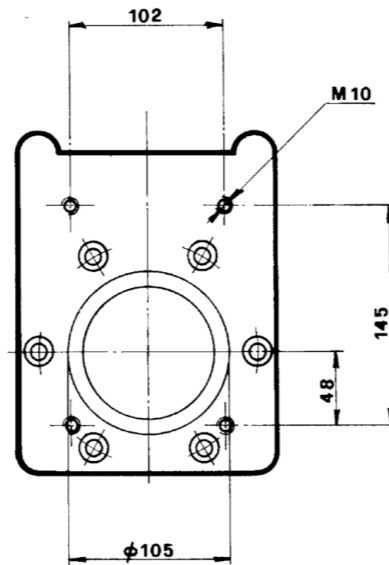

Bosch ZG3 30417

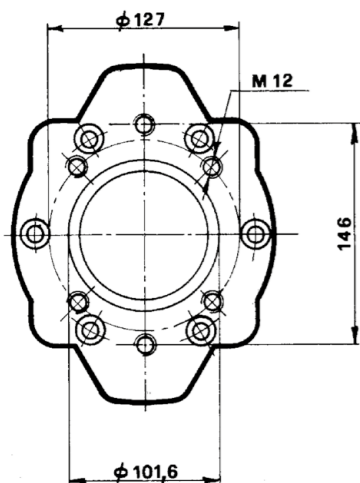

SAE B 2-4 fori  
30421 - 30422

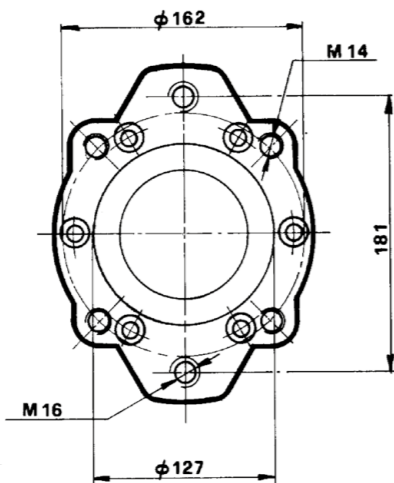

SAE C 2-4 fori  
30431 - 30432

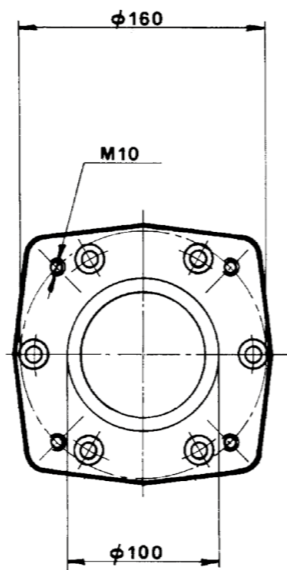

Linde Guldner PF 20-35-50  
30461 - 30462

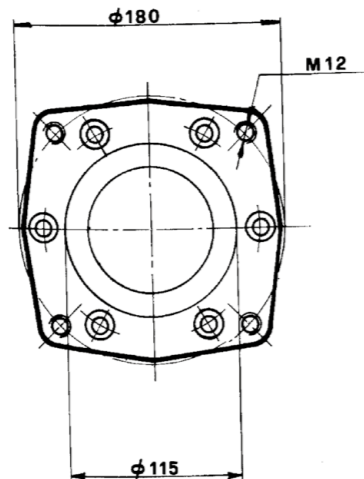

Linde Guldner PF 75  
30463

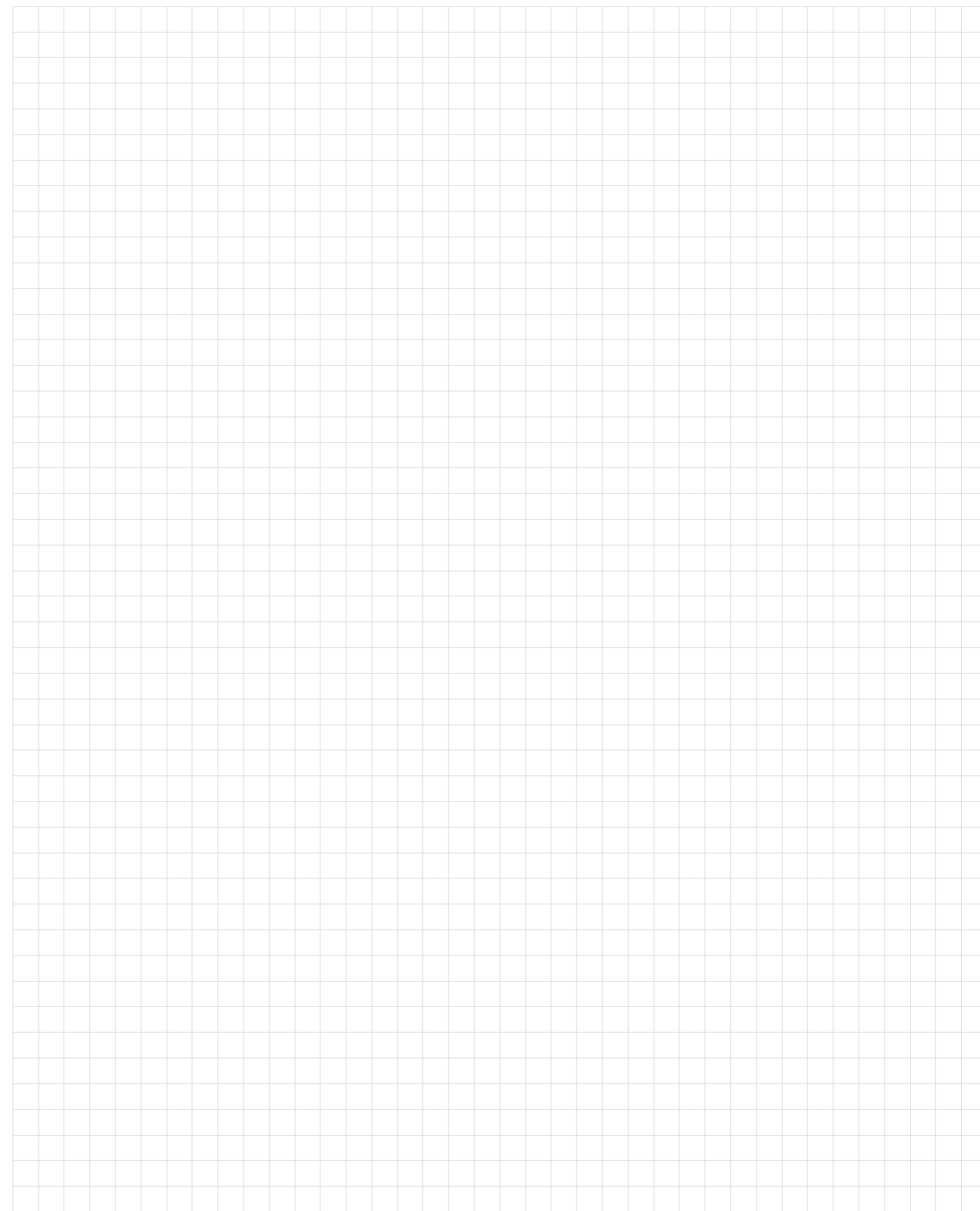



## I nostri cataloghi



## DOVE SIAMO



OLEODINAMICA **BORELLI**  
HYDRAULIC COMPONENTS

**OLEODINAMICA BORELLI**  
di Borelli Claudio

VIA GALVANI, 2 • 42011 BAGNOLO IN PIANO (RE)  
TEL. +39.0522.951628-952080 • FAX +39.0522.951238  
www.oleodinamicaborelli.it • info@oleodinamicaborelli.it





## LubeTeam Hydraulic S.r.l.

*Administration and Headquarter:*

Via Tufara Scautieri, 6

83018 - San Martino Valle Caudina (AV)

*Office and Warehouse:*

S.S. 7 Appia, Km. 237,00

82011 - Airola BN

ITALY

Tel. +39 0823 950 994

Fax +39 0823 412 546

[www.lubeteam.it](http://www.lubeteam.it) [info@lubeteam.it](mailto:info@lubeteam.it)

Italian VAT / C.F. e P.IVA: 01251720627

Follow us



This document is the property of LubeTeam Hydraulic S.r.l. All data reported here are for the exclusive use of the Receiver. Reproduction is not authorized without writing permission, in all or in part of the content of this document, in accordance to Law 633 art. 171, dated April 22, 1941.

Il presente documento è di proprietà della LubeTeam Hydraulic S.r.l. I dati riportati sono per esclusivo del destinatario. La riproduzione, di tutto o in parte, non è autorizzata senza permesso scritto secondo l'art. 171 della L. 633 del 22 Aprile 1941.