



UFI FILTERS

Filtri Oleodinamici

Filtri in mandata



 HYDRAULIC
COMPONENTS
& FLUID CONTAMINATION
CONTROL



FLA

PRESSURE FILTERS

DESCRIPTION

Inline high pressure last chance filter

MATERIALS

Housing: Aluminum
Seals: NBR Nitrile

PRESSURE

Max. working: 21 MPa (210 bar)
Collapse, differential for the filter element:
8 MPa (80 bar)

FLOW RATE

Qmax 35 l/min

WORKING TEMPERATURE

From -25° to +110° C

COMPATIBILITY (ISO 2943)

Full with fluids: HH-HL-HM-HV-HTG
(according to ISO 6743/4)
For fluids different than the above mentioned,
please contact our Customer Service

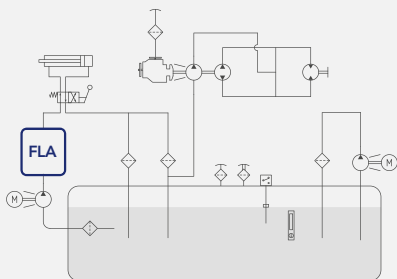

Is this datasheet the latest release? Please check on our website

ORDERING AND OPTION CHART

F	L	A	COMPLETE FILTER FAMILY		FILTER ELEMENT FAMILY	E	L	A
			SIZE & LENGTH	11	SIZE & LENGTH			
		B	PORT TYPE					
			B = BSP thread	B				
			PORT SIZE					
			03 = 3/8"	03				
			04 = 1/2"	04				
		W	BYPASS VALVE					
			W = without	W				
			SEALS		SEALS			
			N = NBR Nitrile	N				
			F = FKM Fluoroelastomer	F				
			FormulaUFI MEDIA		FormulaUFI MEDIA			
			MD = FormulaUFI.WEB 30 µm	MD				
			ME = FormulaUFI.WEB 60 µm	ME				
			MF = FormulaUFI.WEB 90 µm	MF				
			MG = FormulaUFI.WEB 250 µm	MG				
0	0		CLOGGING INDICATOR					
			00 = without predisposition	00				
X	X		ACCESSORI / ACCESSORIES					
			XX = without accessories	XX				

SPARE PARTS

FILTER HOUSING	FILTER ELEMENT
----------------	----------------



B L A 1 1 B W X X 0 0 X X

E L A

SPARE SEAL KIT

	NBR	FKM
FLA11	021.0205.2	021.0206.2



INSTALLATION DRAWING

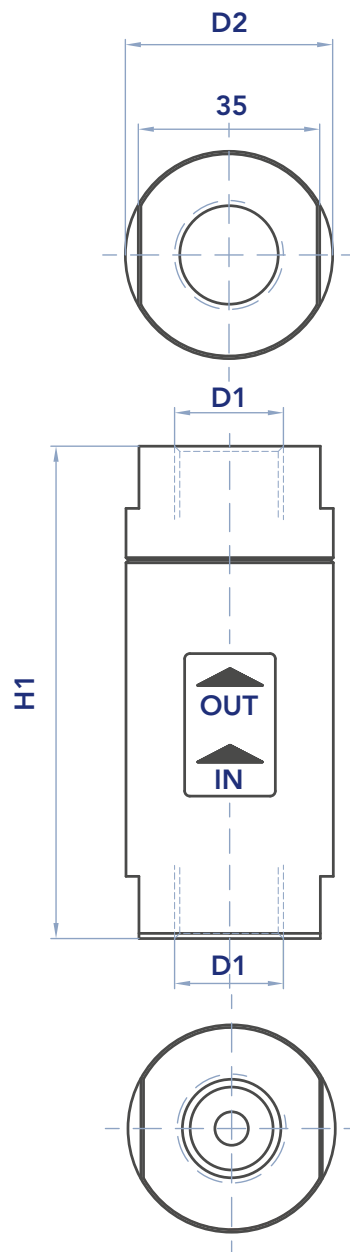

FILTER HOUSING

	D1	D2	H1	kg
FLA11	3/8" - 1/2" BSP	40,0	95,0	0,24

FLA

PRESSURE FILTERS

FILTER ELEMENT

	A	B	C	Kg	AREA (cm ²) Media M+
ELA11	25	7	47	0,04	72

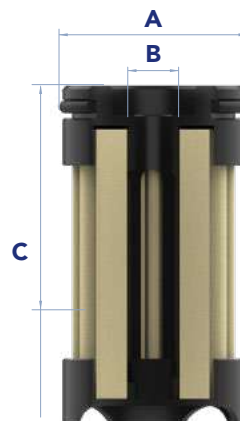

MAINTENANCE

- 1) Stop the system and verify there is no pressure in the filter.
- 2) Collect the oil inside the filter with a suitable container.
- 3) Unscrew the plug (1).
- 4) Remove the dirty filter element (2).
N.B. The exhausted filter elements and the oil dirty filter parts are classified "Dangerous waste material" and must be disposed of according to the local laws, by authorised Companies.
- 5) Check the filter element part number on the filter label or in the ordering and option chart.
Use only original spare parts.
- 6) Lubricate the element o-ring gasket (3) with oil.
- 7) Insert the clean element into the plug (1) with care.
- 8) Check the housing o-ring condition (4) and lubricate with oil.
If damaged, check the seal kit part number in the spare seal kit table.
- 9) Screw the plug (1) on the housing (5) it stops, with a tightening torque of 45 Nm +5/0.

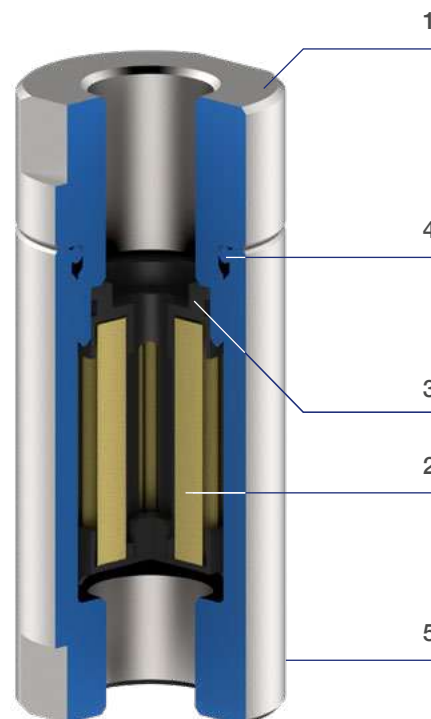



PRESSURE DROP CURVES (Δp)

The “Assembly Pressure Drop (Δp)” is obtained by adding the pressure drop values of the Filter Housing and of the Clean Filter

Element corresponding to the considered Flow Rate and it must be lower than 120 kPa (1,2 bar).

FILTER HOUSING PRESSURE DROP
(mainly depending on the port size)

CLEAN FILTER ELEMENT PRESSURE DROP WITH M+ MEDIA
(depending both on the internal diameter of the element and on the filter media)

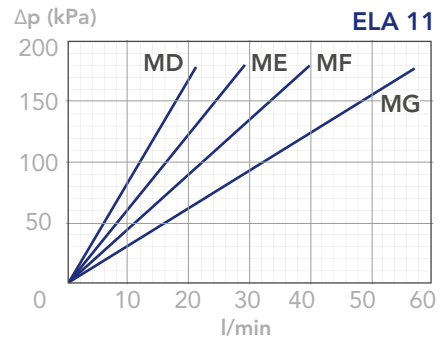
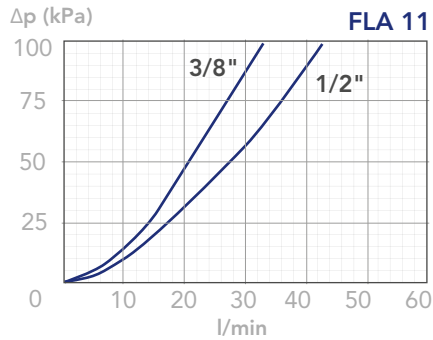

N.B.

All the curves have been obtained with mineral oil having a kinematic viscosity 30 cSt and specific gravity 0,86 kg/dm³; for fluids with different features, please consider the factors described in the first part of this catalogue. All the curves are

obtained from test done at the UFI FILTERS HYDRAULICS Laboratory, according to the specification ISO 3968:2005. In case of discrepancy, please check the contamination level, viscosity and features of the fluid in use.



FPA

PRESSURE FILTERS

DESCRIPTION

Medium pressure inline filter

MATERIALS

Housing: Anodized aluminum alloy
Bypass valve: Brass
Seals: NBR Nitrile (FKM Fluoroelastomer on request)
Indicator housing: Brass

PRESSURE

Max working: 11 MPa (110 bar)
Collapse, differential for the filter element:
8 MPa (80 bar)

BYPASS VALVE

Setting: 600 kPa (6 bar) \pm 10%

FLOW RATE

Qmax 60 l/min

WORKING TEMPERATURE

From -25° to +110° C

COMPATIBILITY (ISO 2943)

Full with fluids: HH-HL-HM-HV-HTG
(according to ISO 6743/4)
For fluids different than the above mentioned,
please contact our Customer Service

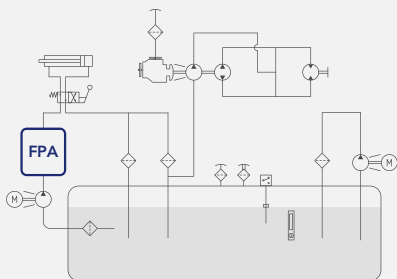

Is this datasheet the latest release? Please check on our website

FPA

PRESSURE FILTERS

ORDERING AND OPTION CHART

F	P	A	COMPLETE FILTER FAMILY			FILTER ELEMENT FAMILY	E	P	A
			SIZE & LENGTH	11	12	SIZE & LENGTH			
			PORT TYPE						
			B = BSP thread	B	B				
			N = NPT thread *	N	N				
			S = SAE thread *	S	S				
			PORT SIZE						
			04 = 1/2" (N04 not available)	04	04				
			BYPASS VALVE						
			W = without	W	W				
			C = 600 kPa (6 bar)	C	C				
			SEALS			SEALS			
			N = NBR Nitrile	N	N				
			F = FKM Fluoroelastomer	F	F				
			G = Treatment for water-glycol	G	G				
			FormulaUFI MEDIA			FormulaUFI MEDIA			
			FA = FormulaUFI.MICRON 5 $\mu\text{m}_{(c)}$ $\beta > 1.000$	FA	FA				
			FB = FormulaUFI.MICRON 7 $\mu\text{m}_{(c)}$ $\beta > 1.000$	FB	FB				
			FC = FormulaUFI.MICRON 12 $\mu\text{m}_{(c)}$ $\beta > 1.000$	FC	FC				
			FS = FormulaUFI.MICRON 16 $\mu\text{m}_{(c)}$ $\beta > 1.000$	FS	FS				
			FD = FormulaUFI.MICRON 21 $\mu\text{m}_{(c)}$ $\beta > 1.000$	FD	FD				
			FE = FormulaUFI.MICRON 30 $\mu\text{m}_{(c)}$ $\beta > 1.000$	FE	FE				
			CLOGGING INDICATOR **						
			03 = port, plugged	03	03				
			5E = visual differential 500 kPa (5 bar)	5E	5E				
			6E = electrical differential 500 kPa (5 bar)	6E	6E				
			7E = indicator 6E with LED	7E	7E				
			T2 = elect. diff. 500 kPa (5 bar) with thermostat 30°C	T2	T2				
X	X		ACCESSORI / ACCESSORIES						
			XX = no accessories available	XX	XX				

* Not standard version, please check availability with our Customer Service

**When the filter is ordered with FKM seals, the first digit of the indicator code is a letter (please see Clogging Indicator Chapter for further details)

SPARE PARTS

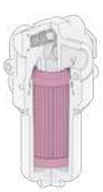
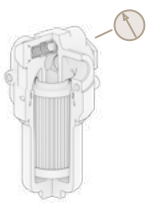
FILTER HOUSING										FILTER ELEMENT					CLOGGING INDICATOR				
																			
B	P	A				0	4												



SPARE SEAL KIT

	NBR	FKM
FPA11 - 12	521.0001.2	521.0062.2

INSTALLATION DRAWING

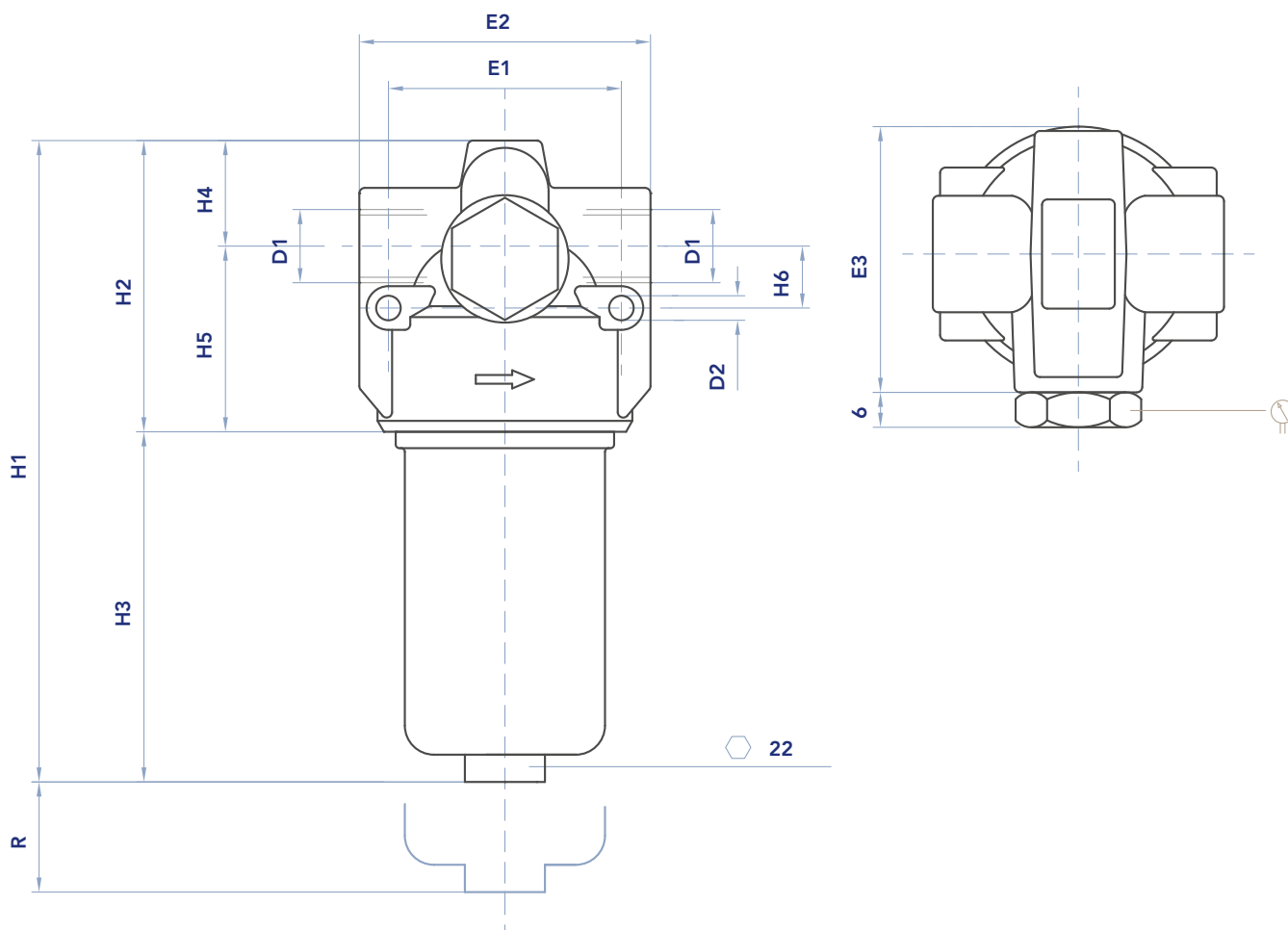

FILTER HOUSING

	D1	D2	H1	H2	H3	H4	H5	H6	E1	E2	E3	R	Kg
FPA11	1/2"	6,5	157	78	79	28	50	17	64	76	75	60	0,65
FPA12	1/2"	6,5	244	78	166	28	50	17	64	76	75	60	0,85

FPA

PRESSURE FILTERS

FILTER ELEMENT

	A	B	C	AREA (cm ²)	
				Kg	Media F+
EPA11	22	42	91	0,15	295
EPA12	22	42	179	0,25	600

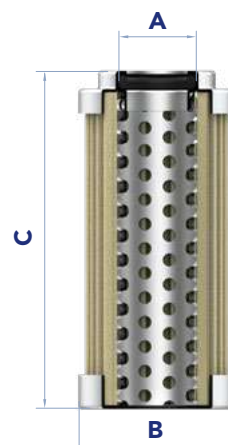

MAINTENANCE

- 1) Stop the system and verify there is no pressure in the filter.
- 2) Collect the oil inside the filter with a suitable container.
- 3) Unscrew the bowl (1) and clean it.
N.B. Never unscrew the by-pass valve (7).
- 4) Remove the dirty filter element (2).
N.B. The exhausted filter elements and the oil dirty filter parts are classified "Dangerous waste material" and must be disposed of according to the local laws, by authorized Companies.
- 5) Check the filter element part number on the filter label or in the ordering and option chart.
Use only original spare parts.
- 6) Lubricate the element o-ring gasket (3) with oil.
- 7) Insert the clean element into its seat with care.
- 8) Check the housing o-ring condition (4) and lubricate with oil
If damaged, check the seal kit part number in the spare seal kit table.
N.B. The anti-extrusion o-ring (5) must be positioned downwards (under the gasket).
- 9) Screw the bowl (1) until it stops, with a tightening torque of 50 Nm +5/0.

Accessories:

Clogging indicator (6).

If damaged, unscrew and replace (check the part number in the ordering and option chart).

Lubricate the o-ring gasket with oil and tighten until it stops, with a tightening torque of 40 Nm +5/0.

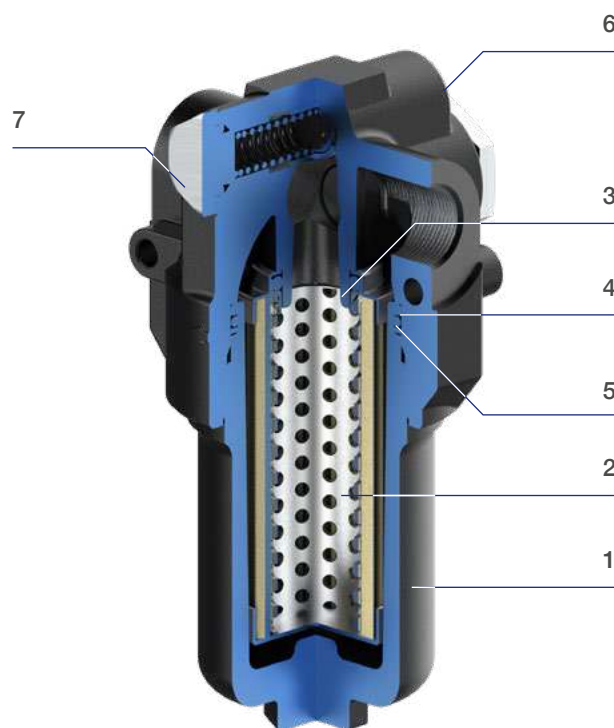



PRESSURE DROP CURVES (Δp)

The “Assembly Pressure Drop (Δp)” is obtained by adding the pressure drop values of the Filter Housing and of the Clean Filter Element corresponding to the considered Flow Rate and it must

be lower than 100 kPa (1 bar). In any case this value should never exceed 1/3 of the bypass valve setting.

BYPASS VALVE PRESSURE DROP

When selecting the filter size, these curves must be taken into account if it is foreseen that any flow peak is to be absorbed by the bypass valve, it also must be of proper configuration to avoid pressure peaks. The valve pressure drop is directly proportional to fluid specific gravity.

FILTER HOUSING PRESSURE DROP
(mainly depending on the port size)

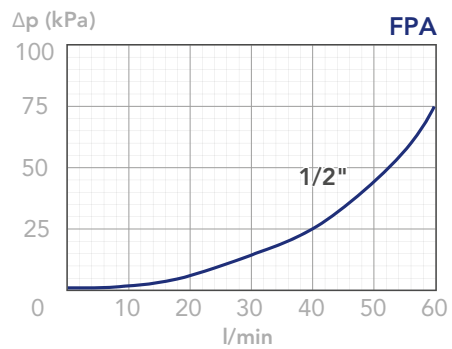
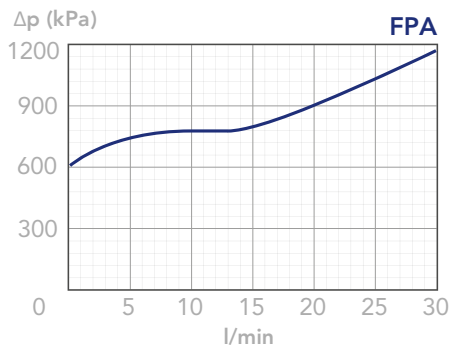

CLEAN FILTER ELEMENT PRESSURE DROP WITH F+ MEDIA
(depending both on the internal diameter of the element and on the filter media)

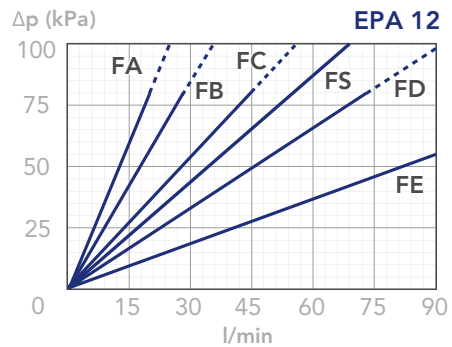
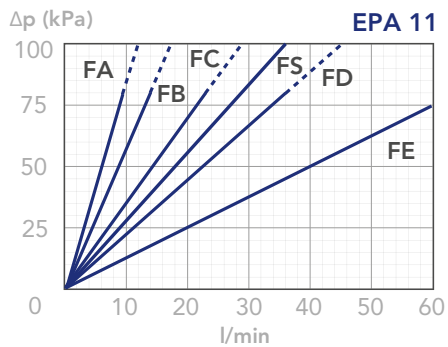

N.B.

All the curves have been obtained with mineral oil having a kinematic viscosity 30 cSt and specific gravity 0,86 kg/dm³; for fluids with different features, please consider the factors described in the first part of this catalogue. All the curves

are obtained from test done at the UFI FILTERS HYDRAULICS Laboratory, according to the specification ISO 3968. In case of discrepancy, please check the contamination level, viscosity and features of the fluid in use.



FPB

PRESSURE FILTERS

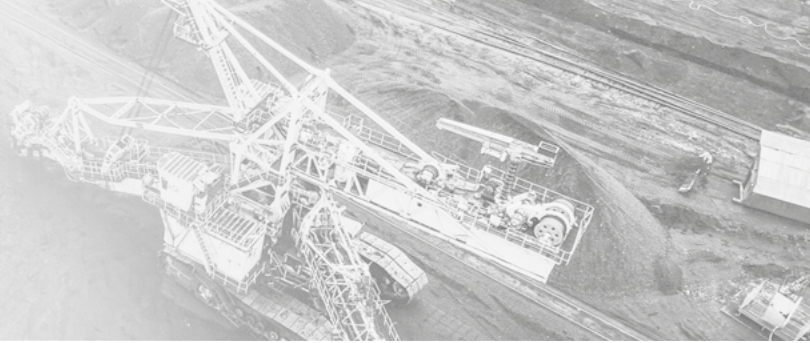

DESCRIPTION

High pressure inline filter

MATERIALS

Head: Cast iron
Bowl: Steel
Bypass valve: Steel
Seals: NBR Nitrile (FKM Fluoroelastomer on request)
Indicator housing: Brass

PRESSURE

Max. working: 42 MPa (420 bar)
Collapse, differential for the filter element series standard 2 MPa (20 bar)
series H+ 21 MPa (210 bar)

BYPASS VALVE

Setting: 600 kPa (6 bar) \pm 10%

FLOW RATE

Qmax 450 l/min

WORKING TEMPERATURE

From -25° to +110° C

COMPATIBILITY (ISO 2943)

Full with fluids: HH-HL-HM-HV-HTG
(according to ISO 6743/4)
For fluids different than the above mentioned,
please contact our Customer Service

HYDRAULIC DIAGRAM

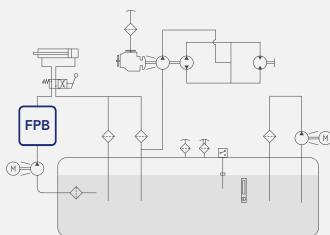

Is this datasheet the latest release? Please check on our website

FPB

PRESSURE FILTERS



ORDERING AND OPTION CHART

F	P	B	COMPLETE FILTER FAMILY	11	12	13	21	22	31	32	33	34	35	FILTER ELEMENT FAMILY	E	P	B
			SIZE & LENGTH											SIZE & LENGTH			
			PORT TYPE														
			B = BSP thread	B	B	B	B	B	B	B	B	B	B				
			N = NPT thread	N	N	N	N	N	N	N	N	N	N				
			S = SAE thread	S	S	S	S	S	S	S	S	S	S				
			F = SAE flange 3000 psi	-	-	-	F	F	F	F	F	F	F				
			G = SAE flange 6000 psi	-	-	-	G	G	G	G	G	G	G				
			PORT SIZE														
			04 = 1/2" (S04 not available)	04	04	04	-	-	-	-	-	-	-				
			06 = 3/4" (F06 not available)	06	06	06	06	06	-	-	-	-	-				
			08 = 1" (G08 not available; F08 for FPB2 only)	-	-	-	08	08	08	08	08	08	08				
			10 = 1" 1/4 (N10 not available)	-	-	-	-	-	10	10	10	10	10				
			12 = 1" 1/2 (G12 option not available)	-	-	-	-	-	12	12	12	12	12				
			BYPASS VALVE														
			W = without	W	W	W	W	W	W	W	W	W	W				
			C = 600 kPa (6 bar)	C	C	C	C	C	C	C	C	C	C				
			R = reverse flow valve*	-	-	-	R	R	R	R	R	R	R				
			P = reverse flow + bypass valve*	-	-	-	P	P	P	P	P	P	P				
			SEALS											SEALS			
			N = NBR Nitrile	N	N	N	N	N	N	N	N	N	N				
			F = FKM Fluoroelastomer	F	F	F	F	F	F	F	F	F	F				
			G = Treatment for water-glycol	G	G	G	G	G	G	G	G	G	G				
			FormulaUFI MEDIA											FormulaUFI MEDIA			
			FA = FormulaUFI.MICRON 5 $\mu\text{m}_{(c)}$ $\beta > 1.000$	FA	FA	FA	FA	FA	FA	FA	FA	FA	FA				
			FB = FormulaUFI.MICRON 7 $\mu\text{m}_{(c)}$ $\beta > 1.000$	FB	FB	FB	FB	FB	FB	FB	FB	FB	FB				
			FC = FormulaUFI.MICRON 12 $\mu\text{m}_{(c)}$ $\beta > 1.000$	FC	FC	FC	FC	FC	FC	FC	FC	FC	FC				
			FS = FormulaUFI.MICRON 16 $\mu\text{m}_{(c)}$ $\beta > 1.000$	FS	FS	FS	FS	FS	FS	FS	FS	FS	FS				
			FD = FormulaUFI.MICRON 21 $\mu\text{m}_{(c)}$ $\beta > 1.000$	FD	FD	FD	FD	FD	FD	FD	FD	FD	FD				
			FE = FormulaUFI.MICRON 30 $\mu\text{m}_{(c)}$ $\beta > 1.000$	FE	FE	FE	FE	FE	FE	FE	FE	FE	FE				
			HA = FormulaUFI.MICRON 5 $\mu\text{m}_{(c)}$ $\beta > 1.000$	HA	HA	HA	HA	HA	HA	HA	HA	HA	HA				
			HB = FormulaUFI.MICRON 7 $\mu\text{m}_{(c)}$ $\beta > 1.000$	HB	HB	HB	HB	HB	HB	HB	HB	HB	HB				
			HC = FormulaUFI.MICRON 12 $\mu\text{m}_{(c)}$ $\beta > 1.000$	HC	HC	HC	HC	HC	HC	HC	HC	HC	HC				
			HD = FormulaUFI.MICRON 21 $\mu\text{m}_{(c)}$ $\beta > 1.000$	HD	HD	HD	HD	HD	HD	HD	HD	HD	HD				
			CLOGGING INDICATOR **														
			03 = port, plugged	03	03	03	03	03	03	03	03	03	03				
			5E = visual differential 500 kPa (5 bar)	5E	5E	5E	5E	5E	5E	5E	5E	5E	5E				
			5F = visual differential 800 kPa (8 bar)	5F	5F	5F	5F	5F	5F	5F	5F	5F	5F				
			6E = electrical differential 500 kPa (5 bar)	6E	6E	6E	6E	6E	6E	6E	6E	6E	6E				
			6F = electrical differential 800 kPa (8 bar)	6F	6F	6F	6F	6F	6F	6F	6F	6F	6F				
			7E = indicator 6E with LED	7E	7E	7E	7E	7E	7E	7E	7E	7E	7E				
			7F = indicator 6F with LED	7F	7F	7F	7F	7F	7F	7F	7F	7F	7F				
			T2 = elect. diff. 500 kPa (5 bar) with thermostat 30°C	T2	T2	T2	T2	T2	T2	T2	T2	T2	T2				
			T3 = elect. diff. 800 kPa (8 bar) with thermostat 30°C	T3	T3	T3	T3	T3	T3	T3	T3	T3	T3				
X	X		ACCESSORI / ACCESSORIES														
			XX = no accessory available	XX	XX	XX	XX	XX	XX	XX	XX	XX	XX				

* On request only

** When the filter is ordered with FKM seals, the first digit of the indicator code is a letter (please see the Clogging Indicator Chapter for further details)



SPARE PARTS

FILTER HOUSING	FILTER ELEMENT	CLOGGING INDICATOR																																
																																		
<table border="1" style="border-collapse: collapse;"> <tr> <td>B</td><td>P</td><td>B</td><td></td><td></td><td></td><td></td><td></td><td></td><td></td><td></td><td></td><td></td><td></td><td></td><td></td><td></td><td>X</td><td>X</td> </tr> </table>	B	P	B															X	X	<table border="1" style="border-collapse: collapse;"> <tr> <td>E</td><td>P</td><td>B</td><td></td><td></td><td></td><td></td><td></td><td></td><td></td><td></td> </tr> </table>	E	P	B									<table border="1" style="border-collapse: collapse;"> <tr> <td></td><td></td> </tr> </table>		
B	P	B															X	X																
E	P	B																																

SPARE SEAL KIT

	NBR	FKM
FPB11 - 12 - 13	521.0002.2	521.0086.2
FPB21 - 22	521.0003.2	521.0030.2
FPB31 - 32 - 33 - 34 - 35	521.0004.2	521.0087.2

FPB

PRESSURE FILTERS

INSTALLATION DRAWING

FPB1

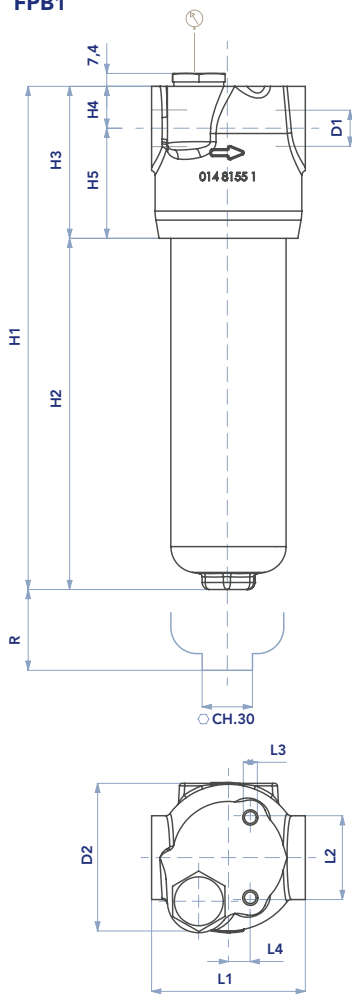

FPB2

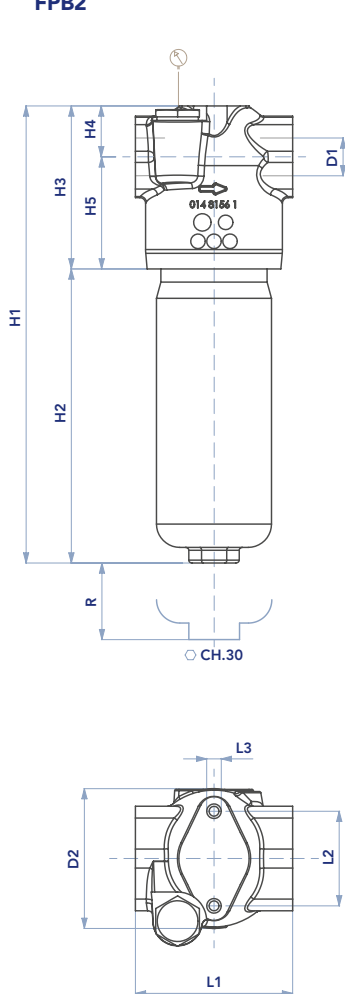

FPB 31-32-33

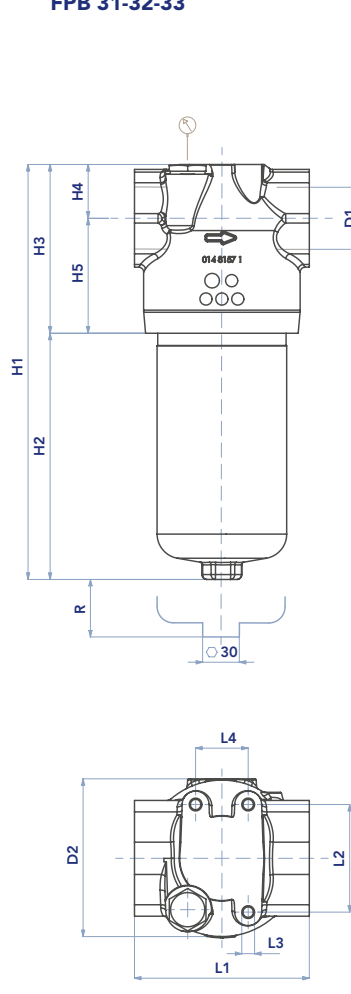

FPB 34-35

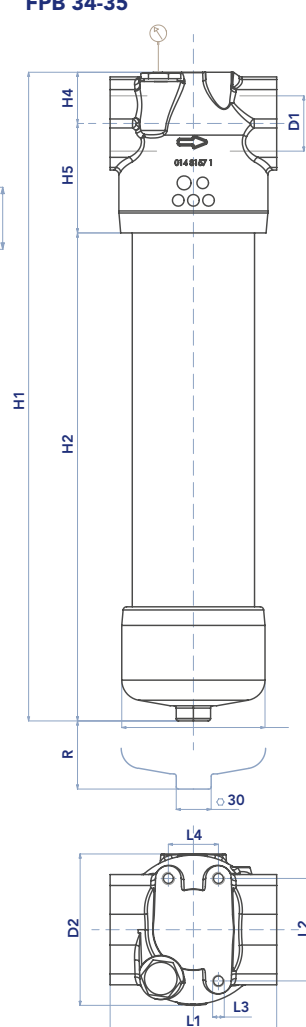

FILTER HOUSING

	D1	D2	H1	H2	H3	H4	H5	L1	L2	L3	L4	R	kg
FPB11	1/2"-3/4"	86	162	75	87	24	63	88	46	M8	12,5	100	4,4
FPB12	1/2"-3/4"	86	194	107	87	24	63	88	46	M8	12,5	100	4,6
FPB13	1/2"-3/4"	86	288	201	87	24	63	88	46	M8	12,5	100	5,2
FPB21	3/4" - 1"	96	219	107	112	35	77	108	65	M8	-	100	6,6
FPB22	3/4" - 1"	96	314	202	112	35	77	108	65	M8	-	100	8,2
FPB31	1" - 1"1/4 - 1"1/2	130	243	105	138	44	94	143	88	M10	43	100	11,0
FPB32	1" - 1"1/4 - 1"1/2	130	337	199	138	44	94	143	88	M10	43	100	13,9
FPB33	1" - 1"1/4 - 1"1/2	130	460	322	138	44	94	143	88	M10	43	100	17,2
FPB34	1" - 1"1/4 - 1"1/2	130	558	420	138	44	94	143	88	M10	43	100	22,0
FPB35	1" - 1"1/4 - 1"1/2	130	658	520	138	44	94	143	88	M10	43	100	25,0



FILTER ELEMENT

	Kg			AREA (cm ²)				
	A	B	C	Media F & C	Media H	Media F+	Media H+	Media C+
EPB11	45	25	85	0,15	0,25	355	340	310
EPB12	45	25	116	0,20	0,55	500	475	435
EPB13	45	25	211	0,30	0,45	935	915	815
EPB21	52	23,5	115	0,25	0,40	975	975	780
EPB22	52	23,5	210	0,35	0,55	1.830	1.785	1.465
EPB31	78	42,5	118	0,40	0,70	2.000	1.470	1.720
EPB32	78	42,5	210	0,80	1,30	3.695	2.695	3.170
EPB33	78	42,5	330	1,00	1,60	5.025	4.325	4.025
EPB34	78	42,5	430	1,20	1,80	6.585	5.685	6.585
EPB35	78	42,5	530	1,40	2,00	8.145	7.045	8.645



MAINTENANCE

- 1) Stop the system and verify there is no pressure in the filter.
- 2) Collect the oil inside the filter with a suitable container.
- 3) Unscrew the bowl (1) and clean it.
- 4) Remove the dirty filter element (2).
N.B. The exhausted filter elements and the oil dirty filter parts are classified "Dangerous waste material" and must be disposed of according to the local laws, by authorized Companies.
- 5) Check the filter element part number on the filter label or in the ordering and option chart.
Use only original spare parts.
- 6) Lubricate the element o-ring gasket (3) with oil.
- 7) Insert the clean element into its seat with care.
- 8) Check the bowl o-ring condition (4) and lubricate with oil.
If damaged, check the seal kit part number in the spare seal kit table.
N.B. The anti-extrusion o-ring (5) must be positioned downwards (under the gasket).
- 9) Screw the bowl (1) until it stops, with a tightening torque of 70 Nm + 5/0.

Accessories:

Clogging indicator (6).

If damaged, unscrew and replace it (check the part number in the ordering and option chart).

Lubricate the o-ring gasket with oil and tighten until it stops, with a tightening torque of 40 Nm +5/0.

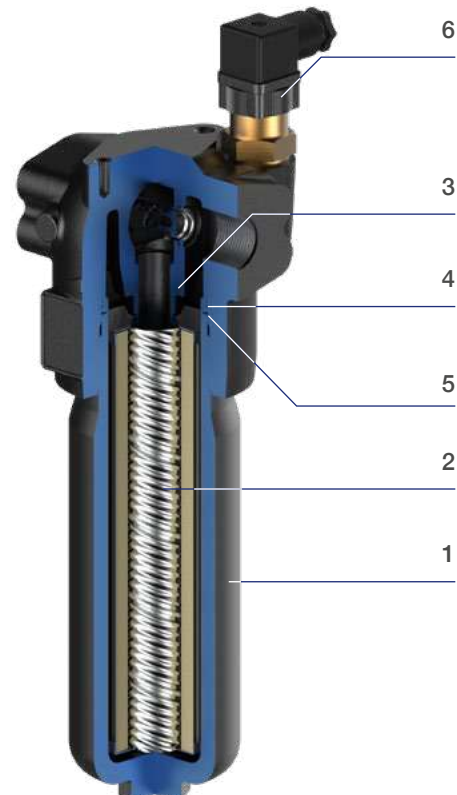

FPB

PRESSURE FILTERS

PRESSURE DROP CURVES (Δp)

The “Assembly Pressure Drop (Δp)” is obtained by adding the pressure drop values of the Filter Housing and of the Clean Filter Element corresponding to the considered Flow Rate and it must be

lower than 120 kPa (1,2 bar). In any case this value should never exceed 1/3 of the bypass valve setting.

FILTER HOUSING PRESSURE DROP
(mainly depending on the port size)

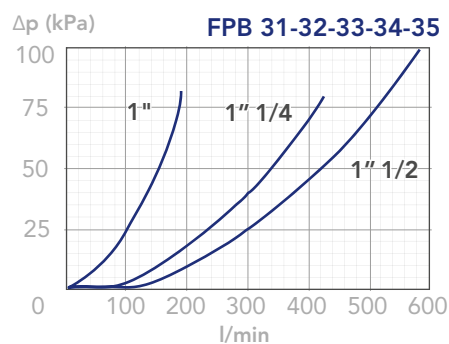
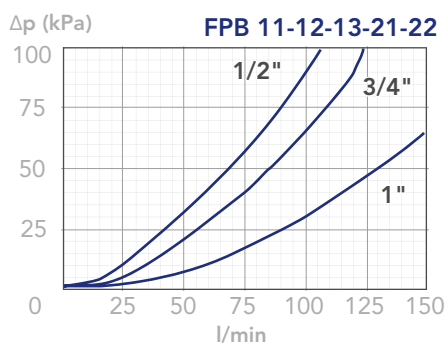

CLEAN FILTER ELEMENT PRESSURE DROP WITH F+ MEDIA
(depending both on the internal diameter of the element and on the filter media)

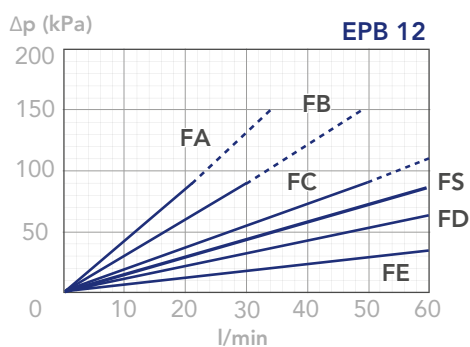
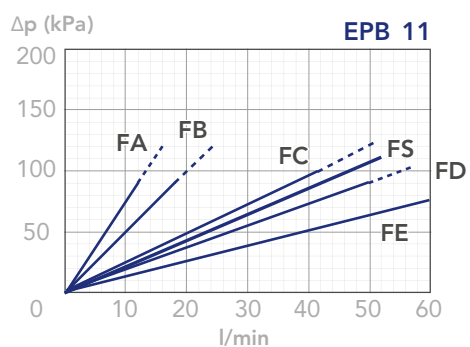



CLEAN FILTER ELEMENT PRESSURE DROP WITH F+ MEDIA
 (depending both on the internal diameter of the element and on the filter media)

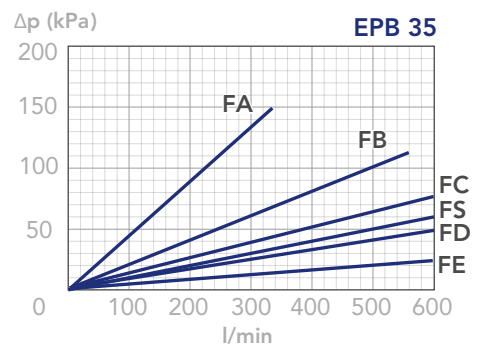
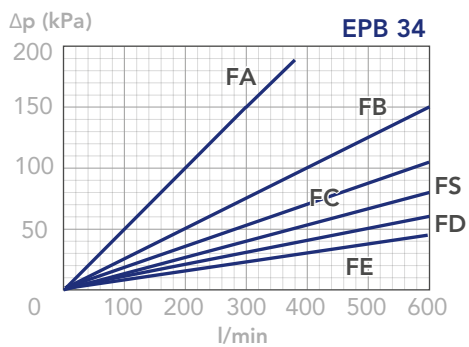
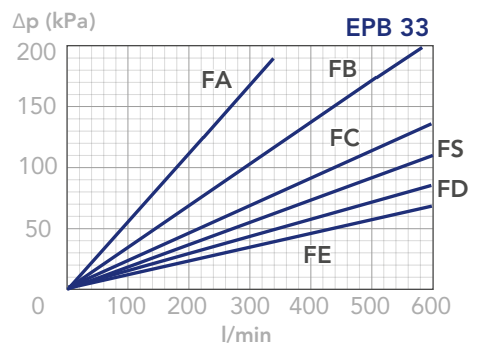
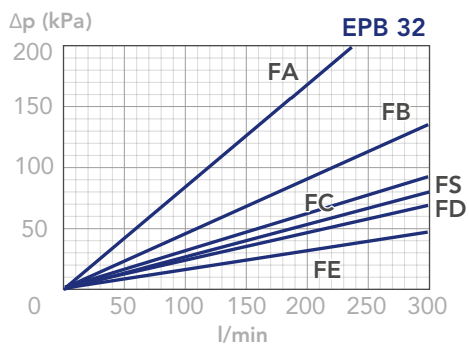
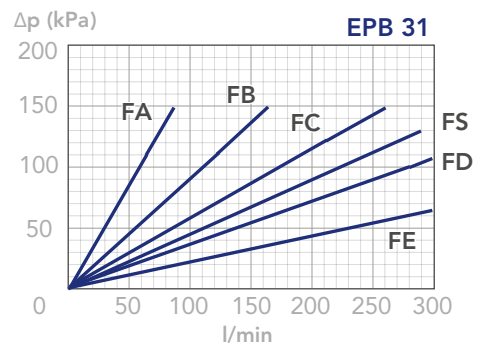
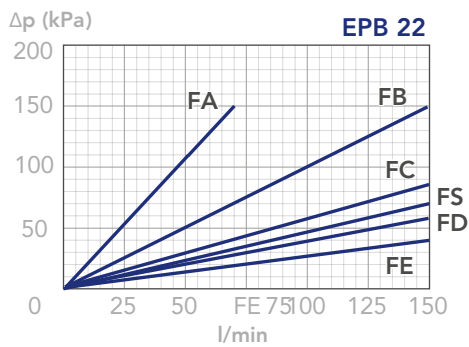
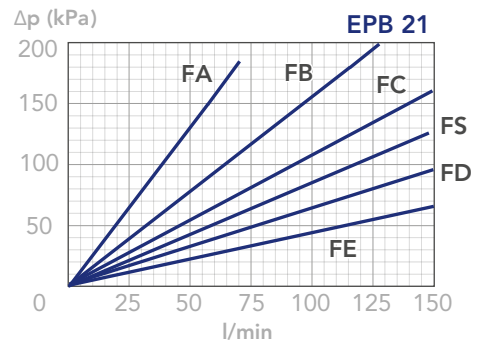
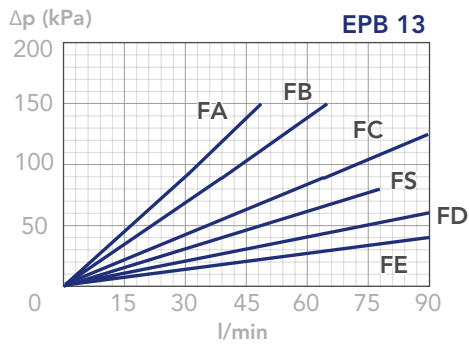

FPB

PRESSURE FILTERS



PRESSURE DROP CURVES (Δp)

The “Assembly Pressure Drop (Δp)” is obtained by adding the pressure drop values of the Filter Housing and of the Clean Filter Element corresponding to the considered Flow Rate and it must be

lower than 120 kPa (1,2 bar). In any case this value should never exceed 1/3 of the bypass valve setting.

CLEAN FILTER ELEMENT PRESSURE DROP WITH H+ MEDIA
(depending both on the internal diameter of the element and on the filter media) - Recommended with no bypass option

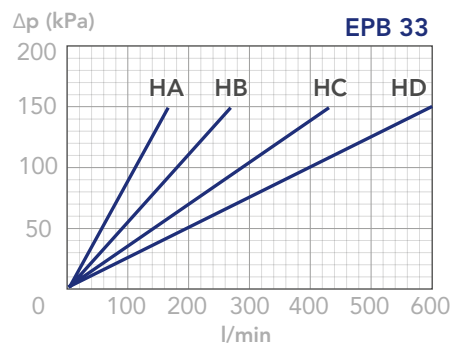
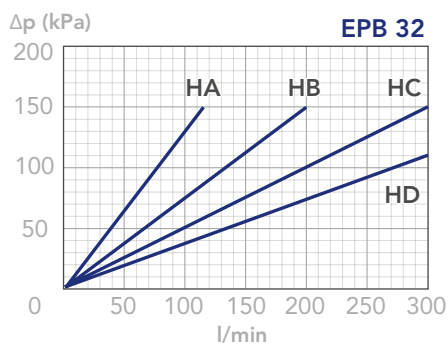
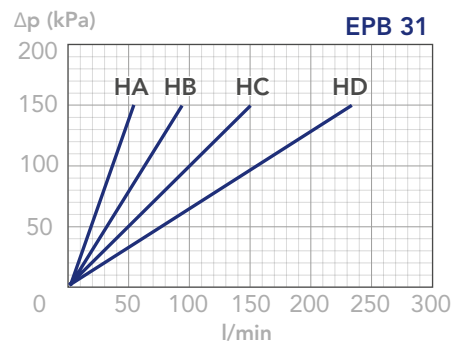
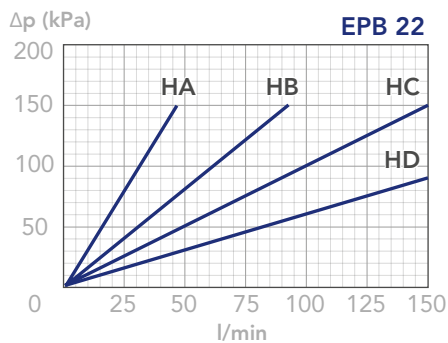
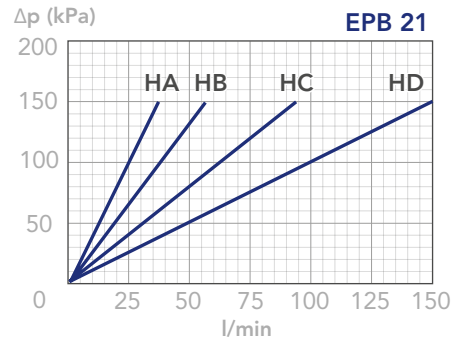
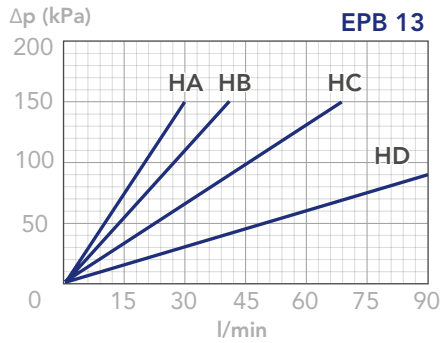
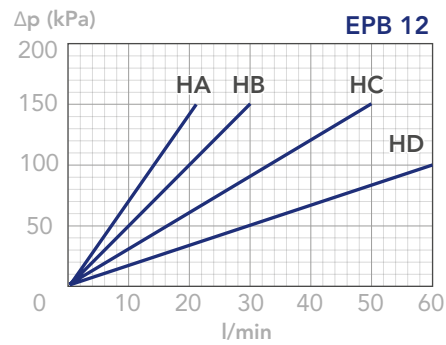
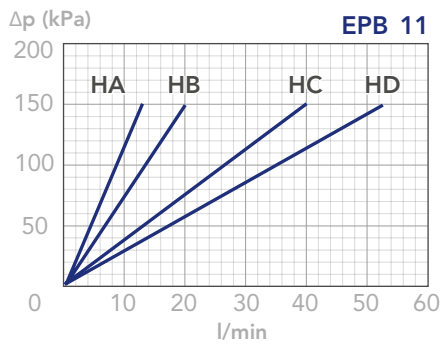

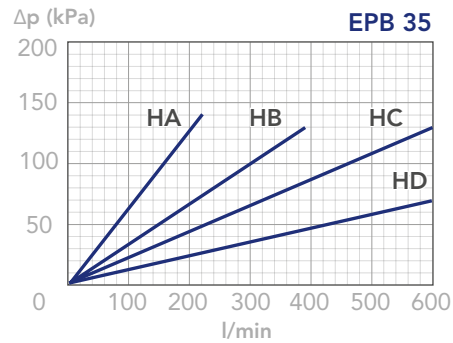
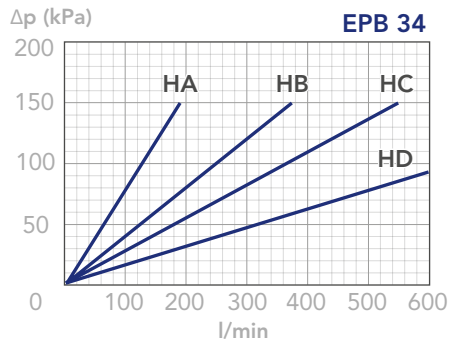

BYPASS VALVE PRESSURE DROP

When selecting the filter size, these curves must be taken into account if it is foreseen that any flow peak is to be absorbed by the bypass valve, it also must be of proper configuration to avoid pressure peaks. The valve pressure drop is directly proportional to fluid specific gravity.

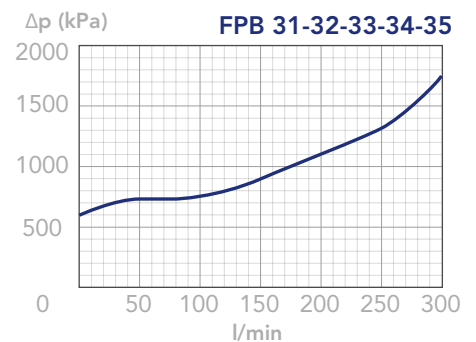
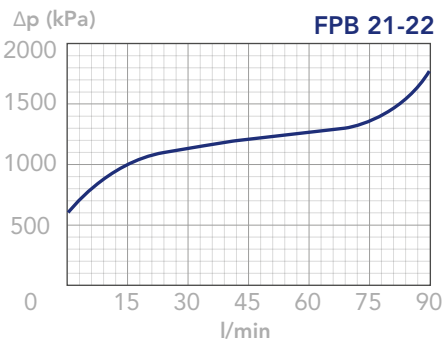
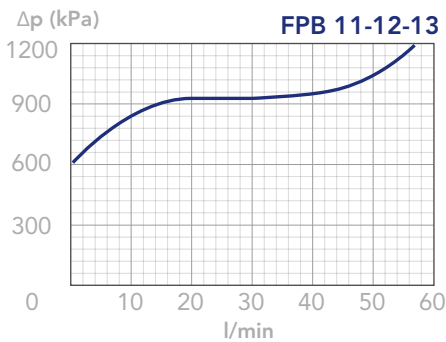

REVERSE FLOW VALVE

For hydraulic systems where reverse flow can occur, the pressure filters series FPB2+ and FPB3+ are available with a free reverse flow valve allowing the fluid to pass through the filter element in the normal direction and to bypass the filter element in the reverse direction (option "R"). The reverse flow valve is available also with incorporated bypass valve for the normal flow direction, set at 6 bar (option "P").

In normal flow conditions the whole flow pass through the filter element. In the option "P", if the differential pressure across the element exceeds 6 bar the bypass is activated.

In reverse flow conditions the flow bypasses the filter element.

Pressure drop through the valve in the reverse direction:

- 0,4 bar at 100 L/min
- 0,6 bar at 200 L/min
- 0,8 bar at 300 L/min

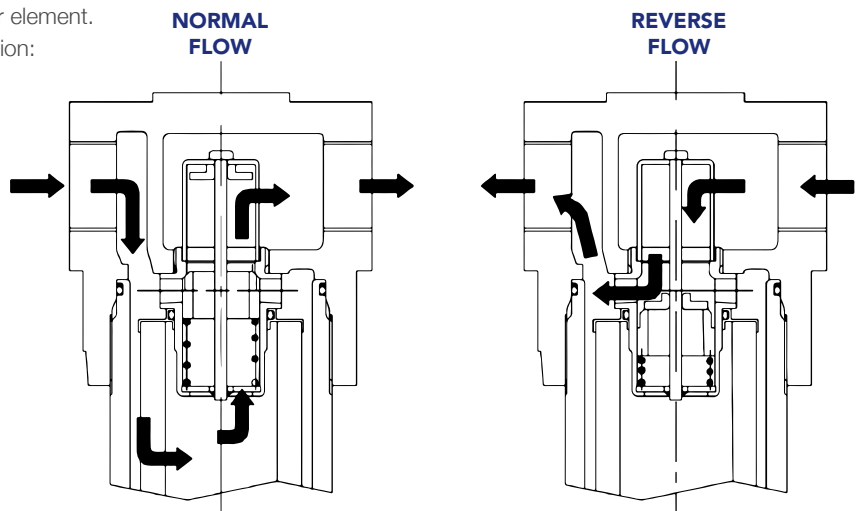

N.B.

All the curves have been obtained with mineral oil having a kinematic viscosity 30 cSt and specific gravity 0,86 kg/dm³; for fluids with different features, please consider the factors described in the first part of this catalogue. All the curves

are obtained from test done at the UFI FILTERS HYDRAULICS Laboratory, according to the specification ISO 3968:2005. In case of discrepancy, please check the contamination level, viscosity and features of the fluid in use.



FPC

PRESSURE FILTERS

DESCRIPTION

High pressure inline filter

MATERIALS

Head: Cast iron

Bowl: Steel

Bypass valve: Steel

Seals: NBR Nitrile (FKM Fluoroelastomer on request)

Indicator housing: Brass

PRESSURE

Max. working: 35 MPa (350 bar)

Collapse, differential for the filter element
standard series 2 MPa (20 bar)

H+ series 21 MPa (210 bar)

BYPASS VALVE

Setting: 350 kPa (3,5 bar) \pm 10%

600 kPa (6 bar) \pm 10%

FLOW RATE

Qmax 150 l/min

WORKING TEMPERATURE

From -25° to +110° C

COMPATIBILITY (ISO 2943)

Full with fluids: HH-HL-HM-HV-HTG

(according to ISO 6743/4)

For fluids different than the above mentioned,
please contact our Customer Service



HYDRAULIC DIAGRAM

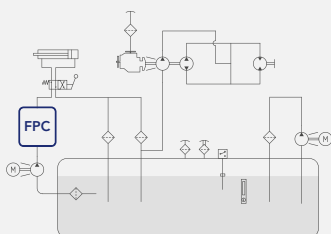

Is this datasheet the latest release? Please check on our website

FPC

PRESSURE FILTERS





ORDERING AND OPTION CHART

F	P	C	COMPLETE FILTER FAMILY				FILTER ELEMENT FAMILY	E	P	C
			SIZE & LENGTH	51	53	55	SIZE & LENGTH			
			PORT TYPE							
			B = BSP thread	B	B	B				
			M = Metric thread (only M22x1,5)	M	M	M				
			S = SAE thread	S	S	S				
			PORT SIZE							
			04 = 1/2"	04	04	04				
			06 = 3/4"	06	06	06				
			08 = 1"	08	08	08				
			BYPASS VALVE							
			W = without	W	W	W				
			C = 600 kPa (6 bar)	C	C	C				
			D = 350 kPa (3,5 bar)	D	D	D				
			SEALS				SEALS			
			N = NBR Nitrile	N	N	N				
			F = FKM Fluoroelastomer	F	F	F				
			G = Treatment for water-glycol	G	G	G				
			FormulaUFI MEDIA				FormulaUFI MEDIA			
			FA = FormulaUFI.MICRON 5 $\mu\text{m}_{(c)}$ >1.000 Δp 2MPa (20 bar)	FA	FA	FA				
			FB = FormulaUFI.MICRON 7 $\mu\text{m}_{(c)}$ >1.000 Δp 2MPa (20 bar)	FB	FB	FB				
			FC = FormulaUFI.MICRON 12 $\mu\text{m}_{(c)}$ >1.000 Δp 2MPa (20 bar)	FC	FC	FC				
			FS = FormulaUFI.MICRON 16 $\mu\text{m}_{(c)}$ >1.000 Δp 2MPa (20 bar)	FS	FS	FS				
			FD = FormulaUFI.MICRON 21 $\mu\text{m}_{(c)}$ >1.000 Δp 2MPa (20 bar)	FD	FD	FD				
			FE = FormulaUFI.MICRON 30 $\mu\text{m}_{(c)}$ >1.000 Δp 2MPa (20 bar)	FE	FE	FE				
			CLOGGING INDICATOR**							
			00 = without predisposition	00	00	00				
			03 = port, plugged	03	03	03				
			5E = visual differential 500 kPa (5 bar)	5E	5E	5E				
			6E = electrical differential 500 kPa (5 bar)	6E	6E	6E				
			7E = indicator 6E with LED	7E	7E	7E				
			XE = electrical differential N.O. 500 kPa (5 bar)	XE	XE	XE				
			XD = electrical differential N.O. 240 kPa (2,4 bar)	XD	XD	XD				
			XL = electrical differential N.C. 240 kPa (2,4 bar)	XL	XL	XL				
			XG = electrical differential N.C. 340 kPa (3,4 bar)	XG	XG	XG				
			T2 = elect. diff. 500 kPa (5 bar) with thermostat 30°C	T2	T2	T2				
			ACCESSORI / ACCESSORIES							
			W = without clogging indicator predisposition	W	W	W				
			A = lateral indicator port (see DWG)	A	A	A				
			C = indicator port on the top (see DWG)	C	C	C				
			ACCESSORI / ACCESSORIES							
			X = no accessory available	X	X	X				

**When the filter is ordered with FKM seals, the first digit of the indicator code is a letter (please see Clogging Indicator Chapter for further details)

SPARE PARTS

FILTER HOUSING										FILTER ELEMENT			CLOGGING INDICATOR	
														
B	P	C								E	P	C		

SPARE SEAL KIT

	NBR	FKM
FPC51-53-55	521.0131.2	521.0132.2

INSTALLATION DRAWING

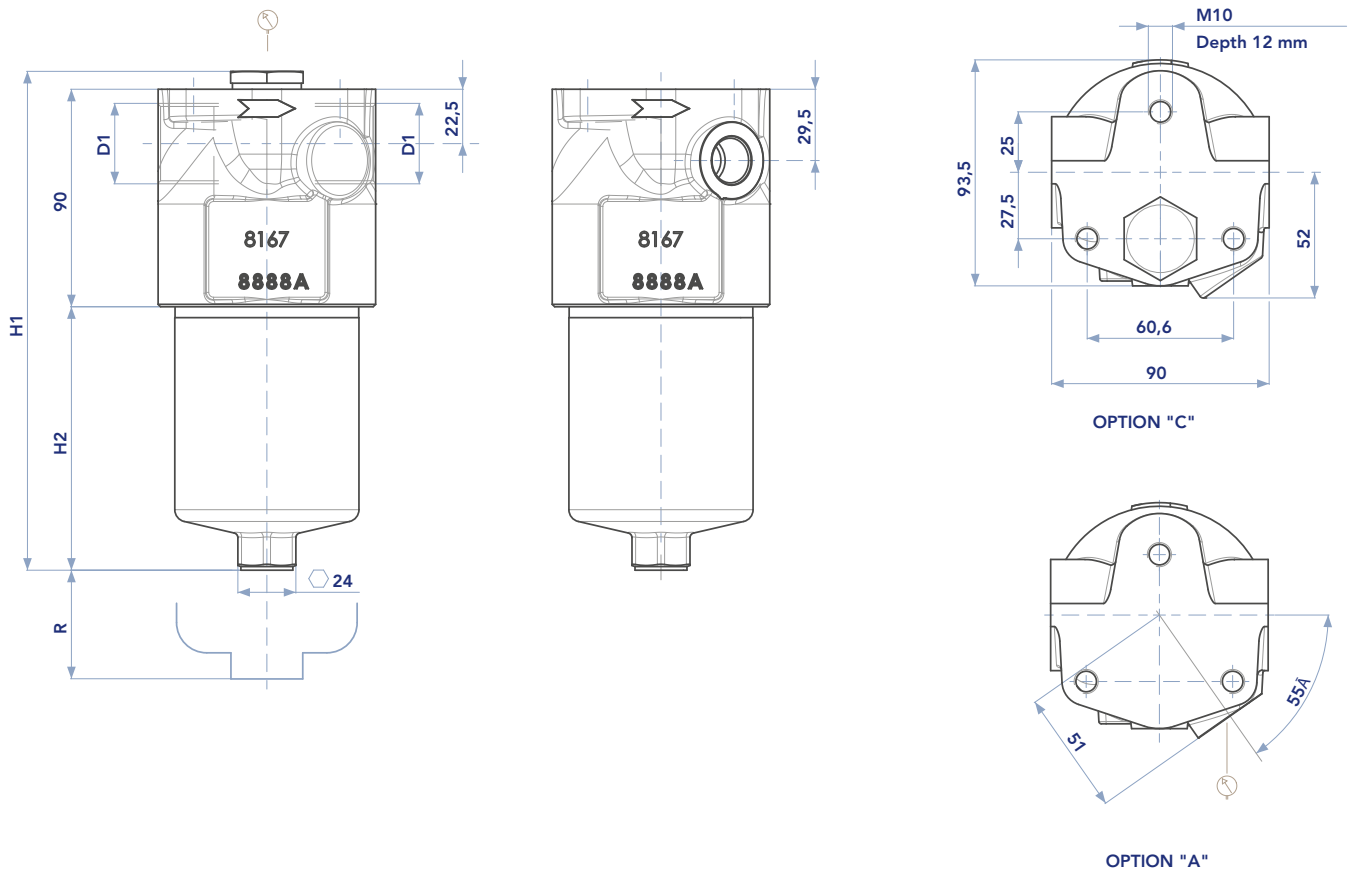

FILTER HOUSING

	D1	H1	H2	Kg
FPC51	M22x1,5 - 1/2" - 3/4" - 1" BSP or SAE thread	206,5	109,0	4,2
FPC53	M22x1,5 - 1/2" - 3/4" - 1" BSP or SAE thread	254,5	157,0	4,7
FPC55	M22x1,5 - 1/2" - 3/4" - 1" BSP or SAE thread	307,0	209,5	5,3

FPC

PRESSURE FILTERS

FILTER ELEMENT

	A	B	C	Kg	AREA (cm ²) Media F+
EPC51	56,5	27	118	0,12	945
EPC53	56,5	27	166	0,15	1.401
EPC55	56,5	27	219	0,19	1.905

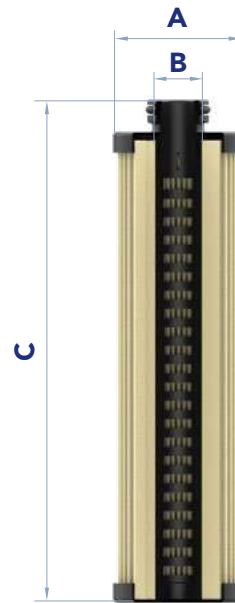

MAINTENANCE

- 1) Stop the system and verify there is no pressure in the filter.
- 2) Collect the oil inside the filter with a suitable container.
- 3) Unscrew the bowl (1) and clean it.
- 4) Remove the dirty filter element (2).
N.B. The used filter elements and oil dirty filter parts dirty are classified "Dangerous waste material" and must be disposed of according to the local laws, by authorized Companies.
- 5) Check the filter element part number on the filter label or in the ordering and option chart.
Use only original spare parts.
- 6) Lubricate the new element o-ring gasket (3) with oil.
- 7) Insert the clean element into its seat with care.
- 8) Check the bowl o-ring condition (4) and lubricate with oil.
If damaged, check the seal kit part number in the spare seal kit table.
N.B. The anti-extrusion o-ring (5) must be positioned downwards (under the gasket).
- 9) Screw the bowl (1) until it stops, with a tightening torque of 70 Nm + 5/0.

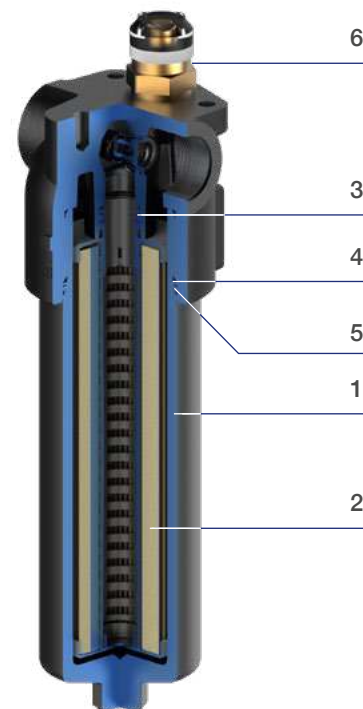

Accessories:

Clogging indicator (6).

If damaged, unscrew and replace it (check the part number in the ordering and option chart).

Lubricate the o-ring gasket with oil and tighten until it stops, with a tightening torque of 40 Nm +5/0.



PRESSURE DROP CURVES (Δp)

The “Assembly Pressure Drop (Δp)” is obtained by adding the pressure drop values of the Filter Housing and of the Clean Filter Element corresponding to the considered Flow Rate and it must be

lower than 120 kPa (1,2 bar). In any case this value should never exceed 1/3 of the bypass valve setting.

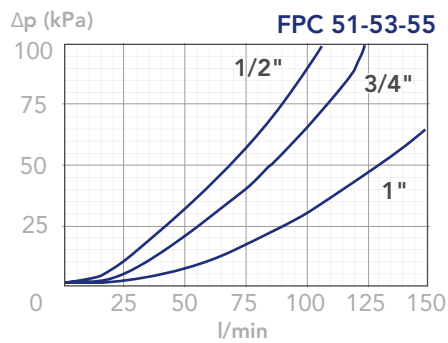

CLEAN FILTER ELEMENT PRESSURE DROP WITH F+ MEDIA
(depending both on the internal diameter of the element and on the filter media)

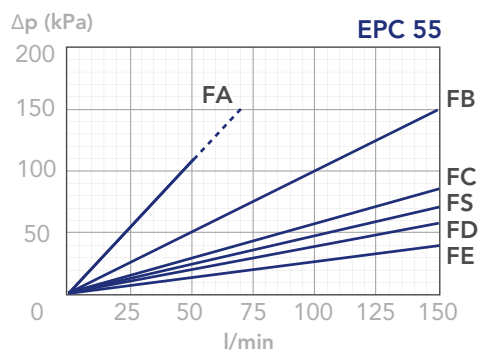
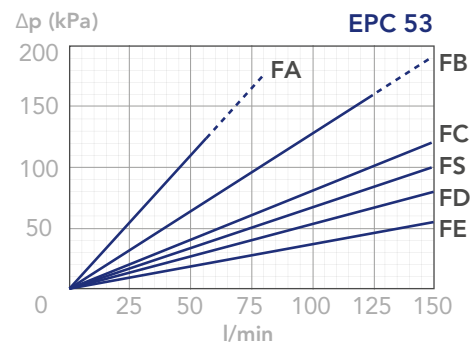
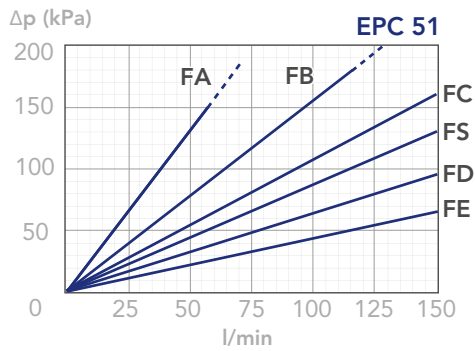

FPC

PRESSURE FILTERS

BYPASS VALVE PRESSURE DROP

When selecting the filter size, these curves must be taken into account if it is foreseen that any flow peak is to be absorbed by the bypass valve, it also must be of proper configuration to avoid pressure peaks. The valve pressure drop is directly proportional to fluid specific gravity.

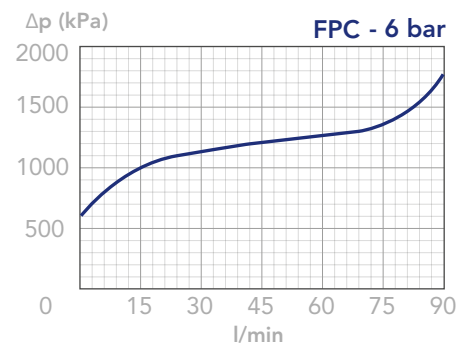
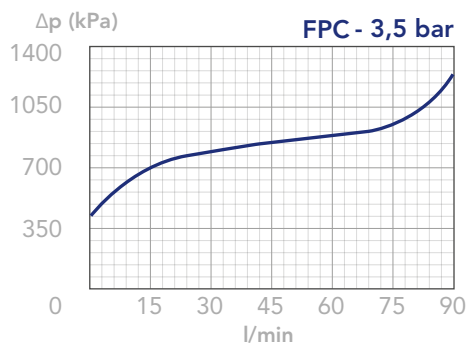

N.B.

All the curves have been obtained with mineral oil having a kinematic viscosity 30 cSt and specific gravity 0,86 kg/dm³; for fluids with different features, please consider the factors described in the first part of this catalogue. All the curves are

obtained from test done at the UFI FILTERS HYDRAULICS Laboratory, according to the specification ISO 3968:2005. In case of discrepancy, please check the contamination level, viscosity and features of the fluid in use.



FPD

PRESSURE FILTERS

DESCRIPTION

Modular inline filter

MATERIALS

Head: Cast iron
Bowl: Steel
Bypass valve: Steel
Seals: NBR Nitrile (FKM Fluoroelastomer on request)
Indicator housing: Brass

PRESSURE

Max. working: 31,5 MPa (315 bar)
Collapse, differential for the filter element:
21 MPa (210 bar)

FLOW RATE

Qmax 400 l/min

WORKING TEMPERATURE

From -25° to +110° C

COMPATIBILITY (ISO 2943)

Full with fluids: HH-HL-HM-HV-HTG
(according to ISO 6743/4)
For fluids different than the above mentioned,
please contact our Customer Service

HYDRAULIC DIAGRAM

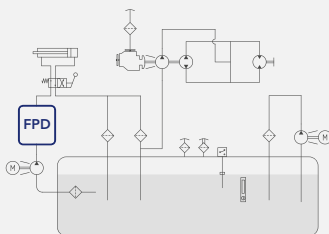

Is this datasheet the latest release? Please check on our website

FPD



PRESSURE FILTERS

ORDERING AND OPTION CHART

F	P	D	COMPLETE FILTER FAMILY											FILTER ELEMENT FAMILY			E	P	B
			SIZE & LENGTH	01	02	12	21	22	31	32	33	34	35						
				01	12	12	21	22	31	32	33	34	35	SIZE & LENGTH					
			PORT TYPE																
			C = CETOP interface	C	C	C	C	C	C	C	C	C	C	C	C	C			
			Y = bowl side B	Y	Y	-	-	-	-	-	-	-	-	-	-				
			PORT SIZE																
			03 = CETOP 3 (size 6)	03	03	-	-	-	-	-	-	-	-	-	-				
			05 = CETOP 5 (size 10)	-	-	05	-	-	-	-	-	-	-	-					
			07 = CETOP 7 (size 16)	-	-	-	07	07	-	-	-	-	-						
			30 = size 30	-	-	-	-	-	30	30	30	30	30						
X			BYPASS VALVE																
			X = not available	X	X	X	X	X	X	X	X	X	X	X	X				
			SEALS																
			N = NBR Nitrile	N	N	N	N	N	N	N	N	N	N	N	N				
			F = FKM Fluoroelastomer	F	F	F	F	F	F	F	F	F	F	F					
			FormulaUFI MEDIA																
			HA = FormulaUFI.MICRON 5 $\mu\text{m}_{(c)}$ $\beta > 1.000 \Delta p 21 \text{ MPa (210 bar)}$	HA	HA	HA	HA	HA	HA	HA	HA	HA	HA	HA					
			HB = FormulaUFI.MICRON 7 $\mu\text{m}_{(c)}$ $\beta > 1.000 \Delta p 21 \text{ MPa (210 bar)}$	HB	HB	HB	HB	HB	HB	HB	HB	HB	HB	HB					
			HC = FormulaUFI.MICRON 12 $\mu\text{m}_{(c)}$ $\beta > 1.000 \Delta p 21 \text{ MPa (210 bar)}$	HC	HC	HC	HC	HC	HC	HC	HC	HC	HC	HC					
			HD = FormulaUFI.MICRON 21 $\mu\text{m}_{(c)}$ $\beta > 1.000 \Delta p 21 \text{ MPa (210 bar)}$	HD	HD	HD	HD	HD	HD	HD	HD	HD	HD	HD					
			CLOGGING INDICATOR**																
			03 = port, plugged	03	03	03	03	03	03	03	03	03	03	03					
			5F = visual differential 800 kPa (8 bar)	5F	5F	5F	5F	5F	5F	5F	5F	5F	5F	5F					
			6F = electrical differential 800 kPa (8 bar)	6F	6F	6F	6F	6F	6F	6F	6F	6F	6F	6F					
			7F = indicator 6F with LED	7F	7F	7F	7F	7F	7F	7F	7F	7F	7F	7F					
			T3 = elect. diff. 800 kPa (8 bar) with thermostat 30°C	T3	T3	T3	T3	T3	T3	T3	T3	T3	T3	T3					
X	X		ACCESSORI / ACCESSORIES																
			XX = no accessories available	XX	XX	XX	XX	XX	XX	XX	XX	XX	XX	XX	XX				

** When the filter is ordered with FKM seals, the first digit of the indicator code is a letter (please see Clogging Indicator Chapter for further details)

SPARE PARTS

FILTER HOUSING				FILTER ELEMENT				CLOGGING INDICATOR			
											
B	P	D	X	E	P	B					



SPARE SEAL KIT

	NBR	FKM
FPD01	521.0005.2	521.0073.2
FPD02	521.0107.2	521.0108.2
FPD12	521.0071.2	521.0074.2

	NBR	FKM
FPD21-22	521.0072.2	521.0028.2
FPD31-32-33-34-35	521.0109.2	521.0110.2

INSTALLATION DRAWING

FPD 01 weight Kg. 2.5

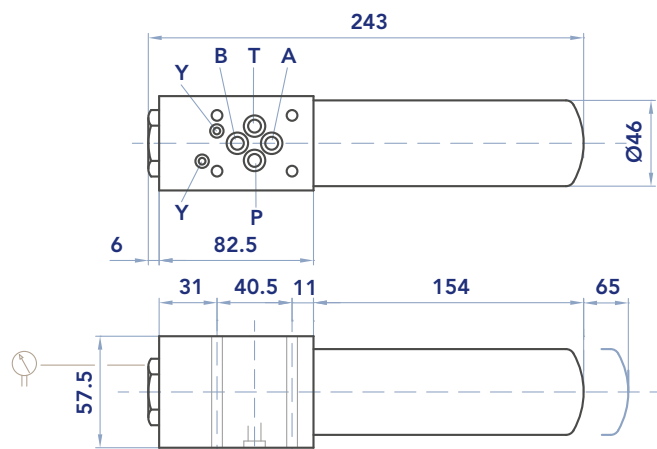
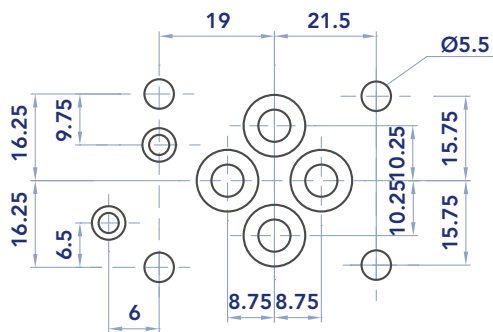

FPD 02 weight Kg. 2.5

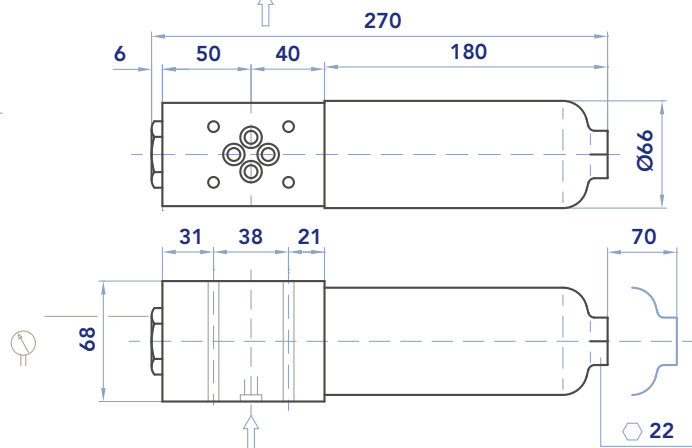
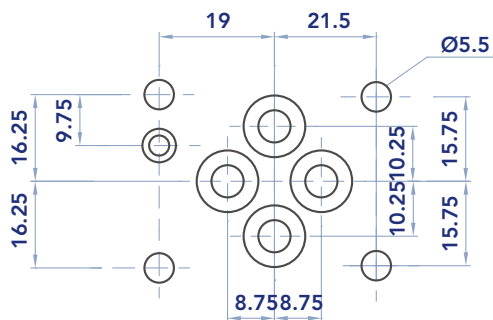

FPD 12 weight Kg. 4.2

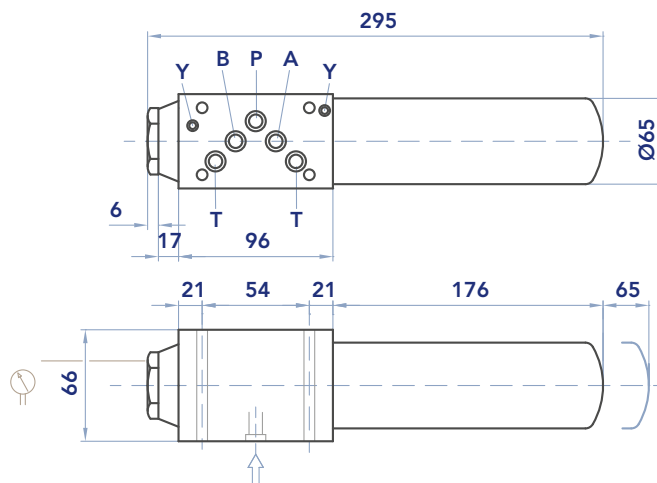
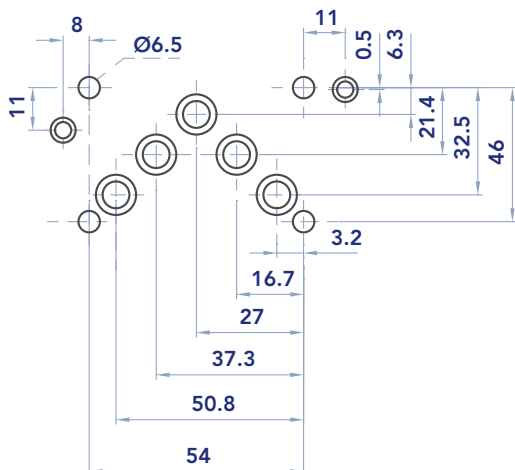

FPD

PRESSURE FILTERS

INSTALLATION DRAWING

FPD 21 weight Kg. 4 - FPD 22 weight Kg. 5.5

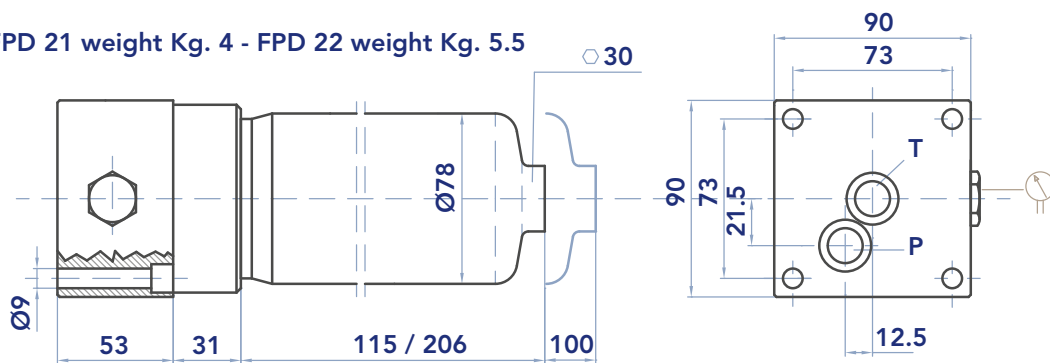

FPD 31 weight Kg. 24 - 32 weight Kg. 27 - 33 weight Kg. 31

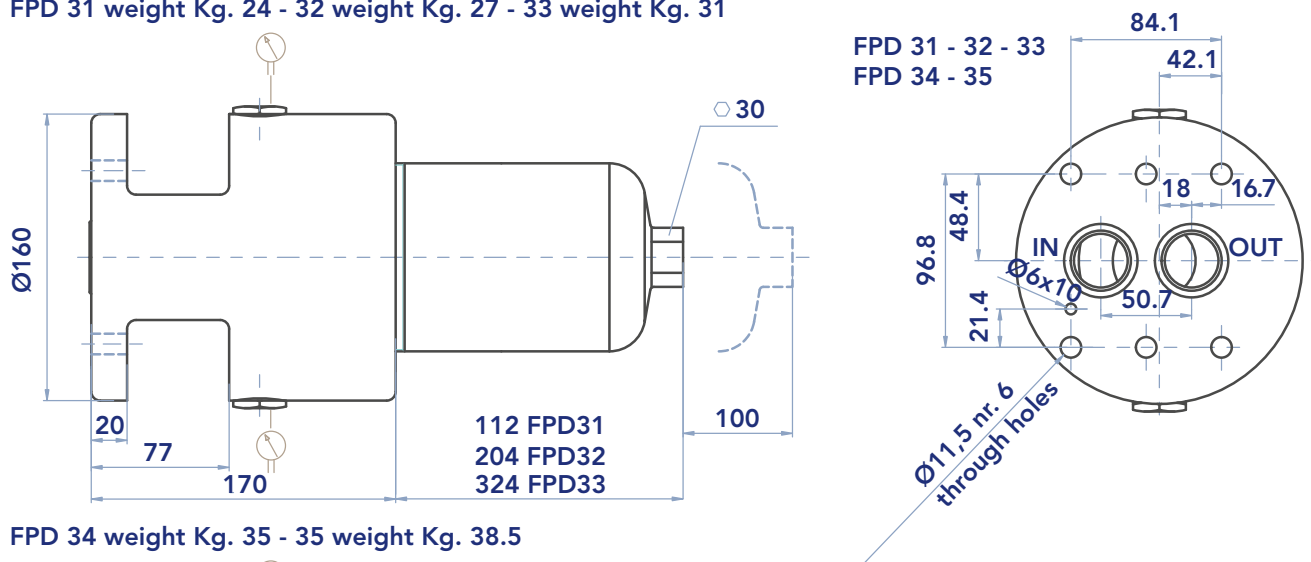

FPD 34 weight Kg. 35 - 35 weight Kg. 38.5

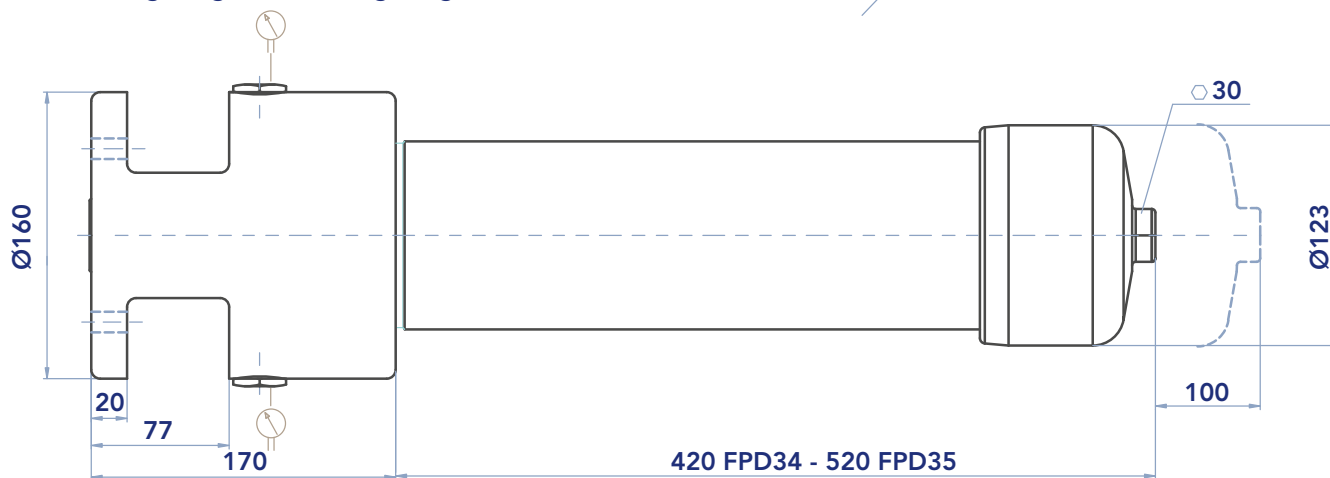



FILTER ELEMENT

	A	B	C	Kg	AREA (cm ²) Media H+
EPB01	33	16	100	0,14	270
EPB12	45	25	116	0,55	475
EPB21	52	23,5	115	0,40	975
EPB22	52	23,5	210	0,55	1.785
EPB31	78	42,5	118	0,70	1.470
EPB32	78	42,5	210	1,30	2.695
EPB33	78	42,5	330	1,60	4.325
EPB34	78	42,5	430	1,80	5.685
EPB35	78	42,5	530	2,00	7.045

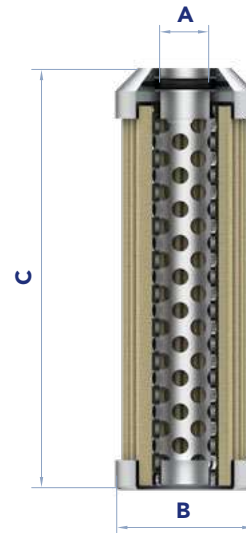

MAINTENANCE

- 1) Stop the system and verify there is no pressure in the filter.
- 2) Collect the oil inside the filter with a suitable container.
- 3) Unscrew the bowl (1) and clean it.
- 4) Remove the dirty filter element (2).
N.B. The exhausted filter elements and the oil dirty filter parts are classified "Dangerous waste material" and must be disposed of according to the local laws, by authorized Companies.
- 5) Check the filter element part number on the filter label or in the ordering and option chart.
Use only original spare parts.
- 6) Lubricate the element o-ring gasket (3) with oil.
- 7) Insert the clean element into its seat with care.
- 8) Check the condition of the o-ring on the bowl (4) and lubricate with oil .
If damaged, check the seal kit part number in the spare seal kit table.
N.B. The anti-extrusion ring (5) must be positioned as follows:
FPD01-FPD02 upwards with the concave part downwards (seal side);
FPD2-FPD3 downwards (in this series the anti-extrusion ring has no concave part).
- 9) Screw the bowl (1) until it stops, with a tightening torque of 70 Nm + 5/0.

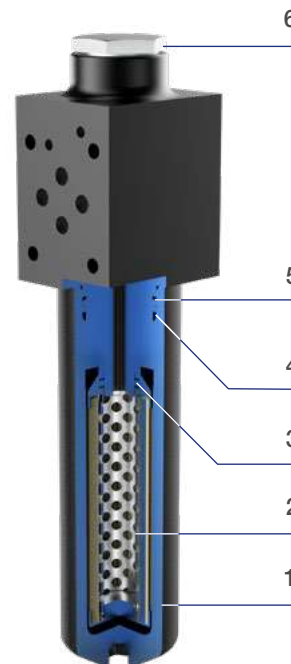

Accessories:

Clogging indicator (6).

If damaged, unscrew and replace it (check the part number in the ordering and option chart).

Lubricate the o-ring gasket with oil and tighten until it stops, with a tightening torque of 40 Nm +5/0.

FPD

PRESSURE FILTERS

PRESSURE DROP CURVES (Δp)

The “Assembly Pressure Drop (Δp)” is obtained by adding the pressure drop values of the Filter Housing and of the Clean Filter

Element corresponding to the considered Flow Rate and it must be lower than 120 kPa (1,2 bar).

FILTER HOUSING PRESSURE DROP
(mainly depending on the port size)

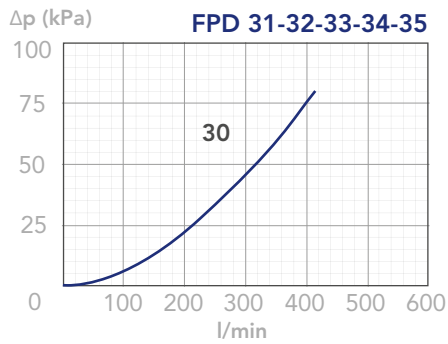
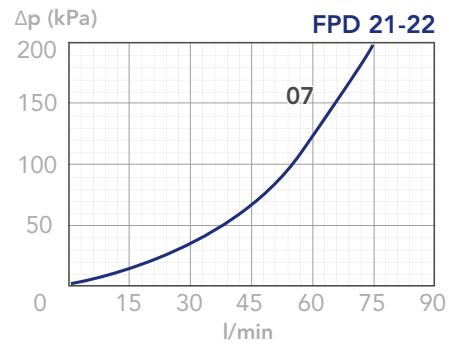
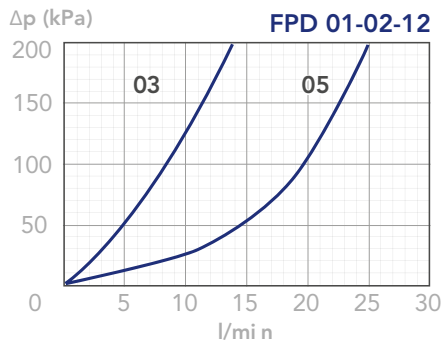



CLEAN FILTER ELEMENT PRESSURE DROP WITH H+ MEDIA
 (depending both on the internal diameter of the element and on the filter media)

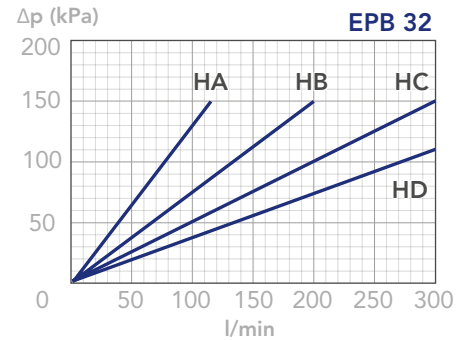
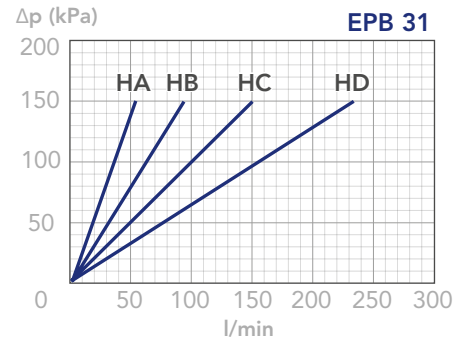
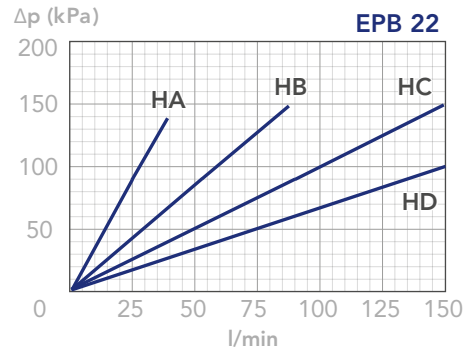
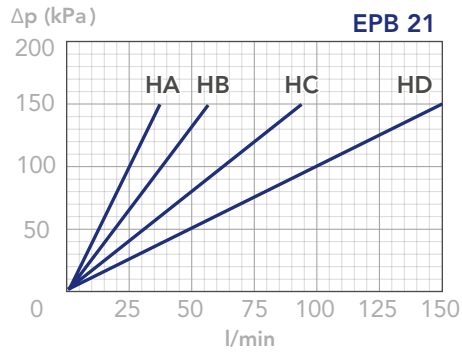
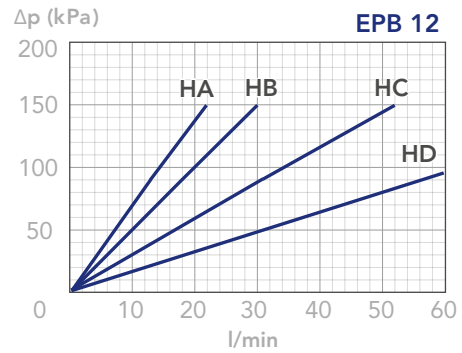
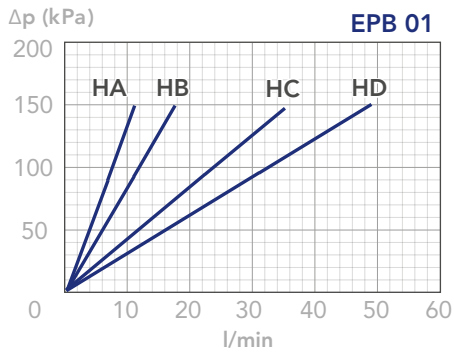

FPD

PRESSURE FILTERS

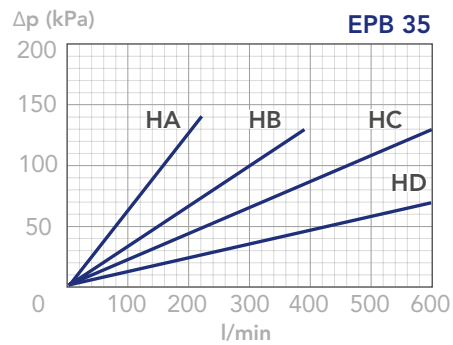
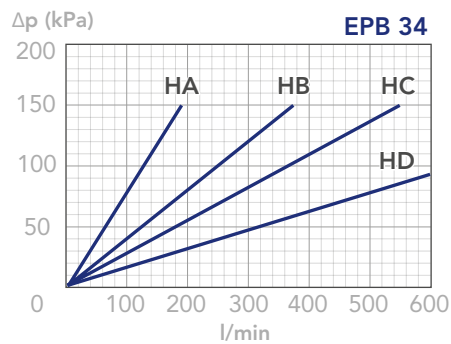
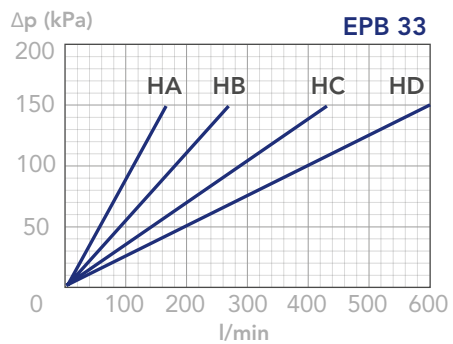

N.B.

All the curves have been obtained with mineral oil having a kinematic viscosity 30 cSt and specific gravity 0,86 kg/dm³; for fluids with different features, please consider the factors described in the first part of this catalogue. All the curves

are obtained from test done at the UFI FILTERS HYDRAULICS Laboratory, according to the specification ISO 3968. In case of discrepancy, please check the contamination level, viscosity and features of the fluid in use.



FPE

PRESSURE FILTERS



DESCRIPTION

Inline spin-on filter

MATERIALS

Head: Aluminum alloy
Spin-on cartridge: Steel
Bypass valve: Polyamide
Seals: NBR Nitrile (FKM Fluoroelastomer on request)
Indicator housing: Brass

PRESSURE

Max working: 1,2 MPa (12 bar)
Collapse, differential for the filter element:
400 kPa (4 bar)

BYPASS VALVE

Setting: 170 kPa (1,7 bar) \pm 10%

FLOW RATE

Qmax 300 l/min

WORKING TEMPERATURE

From -25° to +110° C

COMPATIBILITY (ISO 2943)

Full with fluids: HH-HL-HM-HR-HV-HTG
(according to ISO 6743/4)
For fluids different than the above mentioned,
please contact our Customer Service



HYDRAULIC DIAGRAM

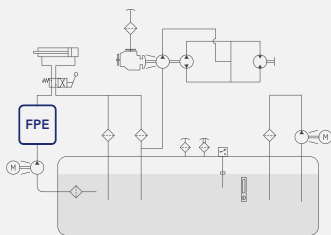

Is this datasheet the latest release? Please check on our website

FPE

PRESSURE FILTERS



ORDERING AND OPTION CHART

F	P	E	COMPLETE FILTER FAMILY									FILTER ELEMENT FAMILY	E	S	E
			SIZE & LENGTH	11	12	21	22	31*	32*	41*	42*	SIZE & LENGTH			
			PORT TYPE												
			B = BSP thread	B	B	B	B	B	B	B	B	B			
			F = SAE flange 3000 psi	-	-	-	-	-	-	F	F				
			PORT SIZE												
			06 = 3/4"	06	06	-	-	-	-	-	-				
			10 = 1" 1/4	-	-	10	10	-	-	-	-				
			12 = 1" 1/2	-	-	-	-	12	12	12	12				
			BYPASS VALVE												
			W = without	W	W	W	W	W	W	W	W				
			B = 170 kPa (1,7 bar)	B	B	B	B	B	B	B	B				
			SEALS												
			N = NBR Nitrile	N	N	N	N	N	N	N	N				
			F = FKM Fluoroelastomer	F	F	F	F	F	F	F	F				
			FormulaUFI MEDIA												
			FA = FormulaUFI.MICRON 5 $\mu\text{m}_{(c)}$ $\beta > 1.000$	FA	FA	FA	FA	FA	FA	FA	FA				
			FB = FormulaUFI.MICRON 7 $\mu\text{m}_{(c)}$ $\beta > 1.000$	FB	FB	FB	FB	FB	FB	FB	FB				
			FC = FormulaUFI.MICRON 12 $\mu\text{m}_{(c)}$ $\beta > 1.000$	FC	FC	FC	FC	FC	FC	FC	FC				
			FD = FormulaUFI.MICRON 21 $\mu\text{m}_{(c)}$ $\beta > 1.000$	FD	FD	FD	FD	FD	FD	FD	FD				
			CC = FormulaUFI.CELL 10 μm $\beta > 2$	CC	CC	CC	CC	CC	CC	CC	CC				
			CD = FormulaUFI.CELL 25 μm $\beta > 2$	CD	CD	CD	CD	CD	CD	CD	CD				
			CLOGGING INDICATOR												
			06 = port, plugged	06	06	06	06	06	06	06	06				
			31 = pressure gauge, rear connection	31	31	31	31	31	31	31	31				
			P1 = SPDT, pressure switch	P1	P1	P1	P1	P1	P1	P1	P1				
X	X		ACCESSORI / ACCESSORIES												
			XX = no accessory available	XX	XX	XX	XX	XX	XX	XX	XX				

* When ordering the filter elements, please consider the following information:
 ESE31 = 2 x ESE21
 ESE32 = 2 x ESE22
 ESE41 = 2 x ESE21
 ESE42 = 2 x ESE22

SPARE PARTS

FILTER HOUSING				FILTER ELEMENT				CLOGGING INDICATOR			
											
B	P	E		E	S	E					



ORDERING AND OPTION CHART - VERSION WITH DIFFERENTIAL INDICATOR

F	P	E	COMPLETE FILTER FAMILY	A1*	A2*	B1*	B2*	31*	32*	41*	42*	FILTER ELEMENT FAMILY	E	S	E
			SIZE & LENGTH									SIZE & LENGTH			
			PORT TYPE												
			B = BSP thread	B	B	B	B	B	B	B	B				
			F = SAE flange 3000 psi	-	-	-	-	-	-	F	F				
			PORT SIZE												
			06 = 3/4" (F06 not available)	06	06	-	-	-	-	-	-				
			10 = 1" 1/4 (N10 not available)	-	-	10	10	-	-	-	-				
			12 = 1" 1/2 (G12 option not available)	-	-	-	-	12	12	12	12				
			BYPASS VALVE												
			W = without	W	W	W	W	W	W	W	W				
			B = 170 kPa (1,7 bar)	B	B	B	B	B	B	B	B				
			SEALS									SEALS			
			N = NBR Nitrile	N	N	N	N	N	N	N	N				
			F = FKM Fluoroelastomer	F	F	F	F	F	F	F	F				
			FormulaUFI MEDIA									FormulaUFI MEDIA			
			FA = FormulaUFI.MICRON 5 $\mu\text{m}_{(c)}$ $\beta > 1.000$	FA	FA	FA	FA	FA	FA	FA	FA				
			FB = FormulaUFI.MICRON 7 $\mu\text{m}_{(c)}$ $\beta > 1.000$	FB	FB	FB	FB	FB	FB	FB	FB				
			FC = FormulaUFI.MICRON 12 $\mu\text{m}_{(c)}$ $\beta > 1.000$	FC	FC	FC	FC	FC	FC	FC	FC				
			FD = FormulaUFI.MICRON 21 $\mu\text{m}_{(c)}$ $\beta > 1.000$	FD	FD	FD	FD	FD	FD	FD	FD				
			CC = FormulaUFI.CELL 10 μm $\beta > 2$	CC	CC	CC	CC	CC	CC	CC	CC				
			CD = FormulaUFI.CELL 25 μm $\beta > 2$	CD	CD	CD	CD	CD	CD	CD	CD				
			CLOGGING INDICATOR**												
			03 = port, plugged	-	-	-	-	03	03	03	03				
			5B = visual differential 130 kPa (1,3 bar)	-	-	-	-	5B	5B	5B	5B				
			6B = electrical differential 130 kPa (1,3 bar)	-	-	-	-	6B	6B	6B	6B				
			7B = indicator 6E with LED	-	-	-	-	7B	7B	7B	7B				
			T0 = elect. diff. 130 kPa (1,3 bar) with thermostat 30°C	-	-	-	-	T0	T0	T0	T0				
			0U = ports, plugged	0U	0U	0U	0U	-	-	-	-				
			U0 = visual differential 130 kPa (1,3 bar)	U0	U0	U0	U0	-	-	-	-				
			N0 = visual-electrical differential 130 kPa (1,3 bar)	N0	N0	N0	N0	-	-	-	-				
X	X		ACCESSORI / ACCESSORIES												
			XX = no accessory available	XX	XX	XX	XX	XX	XX	XX	XX				

* When ordering the filter elements, please consider the following information:

ESEA1 = ESE21
 ESEA2 = ESE22
 ESEB1 = ESE21
 ESEB2 = ESE22
 ESE31 = 2 x ESE21
 ESE32 = 2 x ESE22
 ESE41 = 2 x ESE21
 ESE42 = 2 x ESE22

**When the filter is ordered with FKM seals, the first digit of the indicator code is a letter (please see Clogging Indicator Chapter for further details)

SPARE PARTS

FILTER HOUSING				FILTER ELEMENT				CLOGGING INDICATOR			
B	P	E		E	S	E					

FPE

PRESSURE FILTERS

INSTALLATION DRAWING

FPE 1+ & FPE 2+

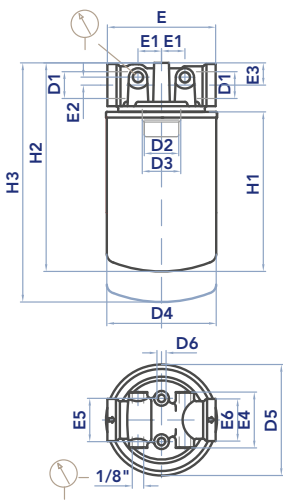

FPE 3+

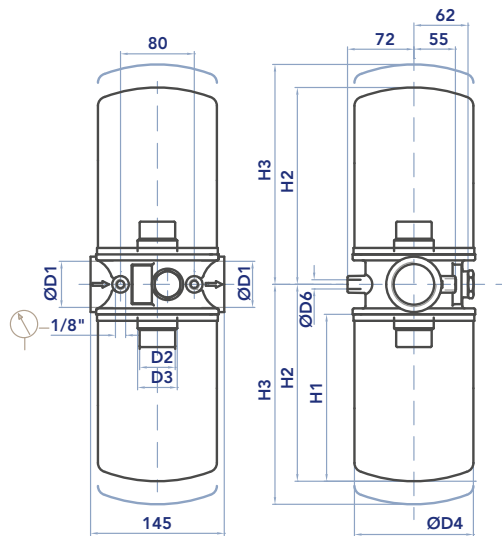

FPE 4+

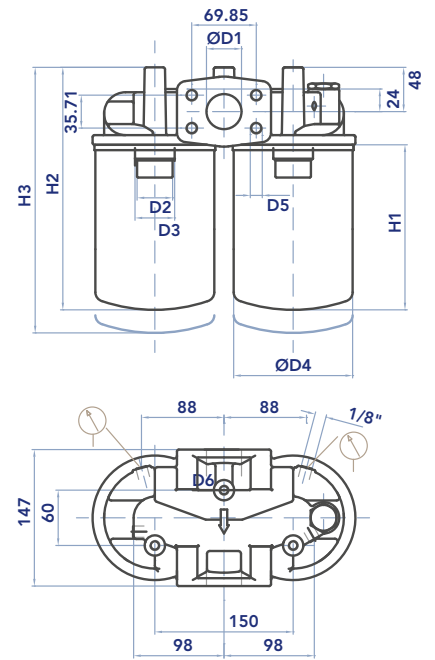

FPE A+ & FPE B+

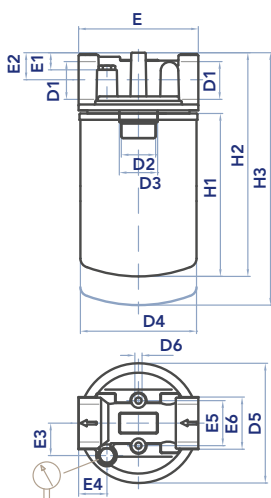

FPE 3+

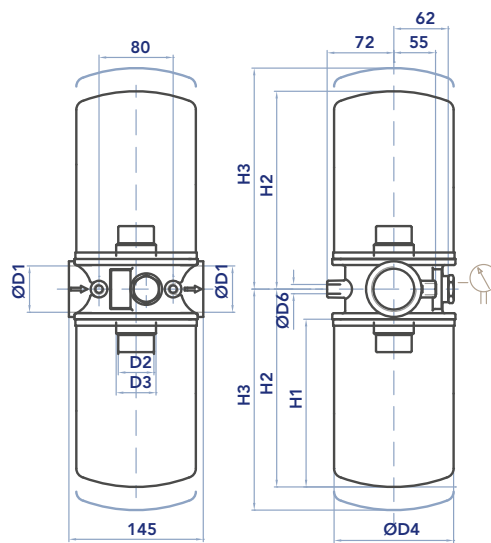

FPE 4+

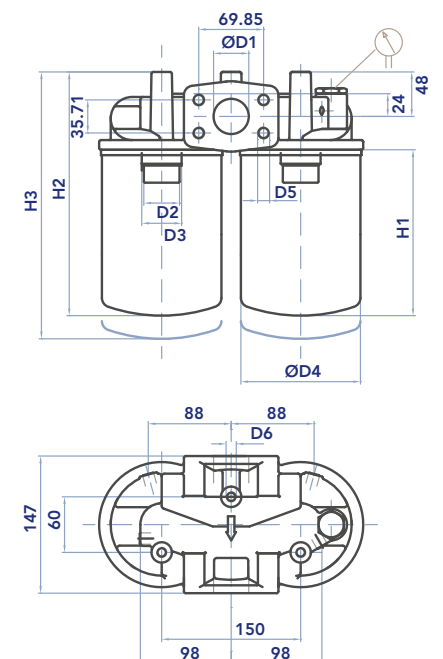



FILTER HOUSING

	D1	D2	D3	D4	D5	D6	E	E1	E2	E4	E5	E6	H1	H2	H3	Kg
FPE11	3/4"	3/4" BSP	-	96	97	M8	95	20,5	7	49	38	37	145	188	208	1,2
FPE12	3/4"	3/4" BSP	-	96	97	M8	95	20,5	7	49	38	37	191	234	254	1,5
FPE21	1"1/4	1"1/2 16-UN	1"1/4 BSP	129	134	M8	133	35	10	64	50	57	181	248	278	1,9
FPE22	1"1/4	1"1/2 16-UN	1"1/4 BSP	129	134	M8	133	35	10	64	50	57	226	293	323	2,0
FPE31	1"1/2	1"1/2 16-UN	1"1/4 BSP	129	-	M10	-	-	-	-	-	-	181	216	246	3,6
FPE32	1"1/2	1"1/2 16-UN	1"1/4 BSP	129	-	M10	-	-	-	-	-	-	226	261	291	3,8
FPE41	1"1/2	1"1/2 16-UN	1"1/4 BSP	129	M12	M10	-	-	-	-	-	-	181	269	299	4,8
FPE42	1"1/2	1"1/2 16-UN	1"1/4 BSP	129	M12	M10	-	-	-	-	-	-	226	314	344	5,0

FILTER HOUSING - VERSION WITH DIFFERENTIAL INDICATOR

	D1	D2	D3	D4	D5	D6	E	E1	E2	E3	E4	E5	E6	H1	H2	H3	Kg
FPEA1	3/4"	3/4" BSP	-	96	96	M8	95	-	23	24,5	21,5	38	32	145	188	208	1,2
FPEA2	3/4"	3/4" BSP	-	96	96	M8	95	-	23	24,5	21,5	38	32	191	234	254	1,5
FPEB1	1"1/4	1"1/2 16-UN	1"1/4 BSP	129	134	M8	133	19	30	36	35	50	54	181	248	278	1,9
FPEB2	1"1/4	1"1/2 16-UN	1"1/4 BSP	129	134	M8	133	19	30	36	35	50	54	226	293	323	2,0
FPE31	1"1/2	1"1/2 16-UN	1"1/4 BSP	129	-	M10	-	-	-	-	-	-	-	181	216	246	3,6
FPE32	1"1/2	1"1/2 16-UN	1"1/4 BSP	129	-	M10	-	-	-	-	-	-	-	226	261	291	3,8
FPE41	1"1/2	1"1/2 16-UN	1"1/4 BSP	129	M12	M10	-	-	-	-	-	-	-	181	269	299	4,8
FPE42	1"1/2	1"1/2 16-UN	1"1/4 BSP	129	M12	M10	-	-	-	-	-	-	-	226	314	344	5,0

FILTER ELEMENT

	A	B	C	Kg	AREA (cm ²)	
					Media F+	MediaC+
ESE11	96,5	3/4" BSP	146	0,70	2.140	3.305
ESE12	96,5	3/4" BSP	191	0,80	3.630	4.745
ESE21	129	1"1/4 BSP	181	1,20	4.450	5.560
ESE22	129	1"1/4 BSP	226	1,40	5.890	7.360

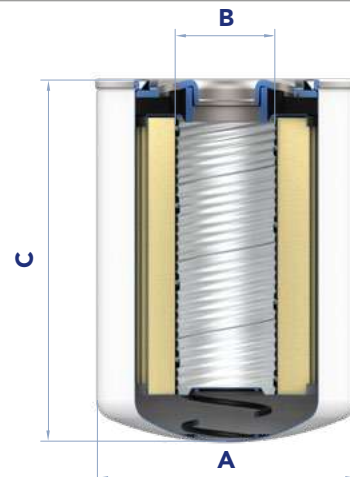

FPE

PRESSURE FILTERS



MAINTENANCE

- 1) Stop the system and verify there is no pressure in the filter.
- 2) Collect the oil inside the filter with a suitable container.
- 3) Unscrew the dirty filter element (1).
N.B. The exhausted filter elements and the oil dirty filter parts are classified "Dangerous waste material" and must be disposed of according to the local laws, by authorized Companies.
- 4) Check the filter element part number on the silk-screen printing or in the ordering and option chart.
Use only original spare parts.
- 5) Lubricate the element o-ring gasket with oil.
- 6) Screw the clean filter element until the first contact of the gasket with the flange.
- 7) Tighten strongly for $\frac{3}{4}$ of a turn (indicative tightening torque of 18 Nm).

Accessories:

Clogging indicator (6).

If damaged, unscrew and replace it (check the part number in the ordering and option chart).

Lubricate the o-ring gasket with oil and tighten until it stops, with a tightening torque of 40 Nm +5/0.



PRESSURE DROP CURVES (Δp)

The "Assembly Pressure Drop (Δp)" is obtained by adding the pressure drop values of the Filter Housing and of the Clean Filter Element corresponding to the considered Flow Rate and it must

be lower than 50 kPa (0,5 bar). In any case this value should never exceed 1/3 of the bypass valve setting.

FILTER HOUSING PRESSURE DROP
(mainly depending on the port size)

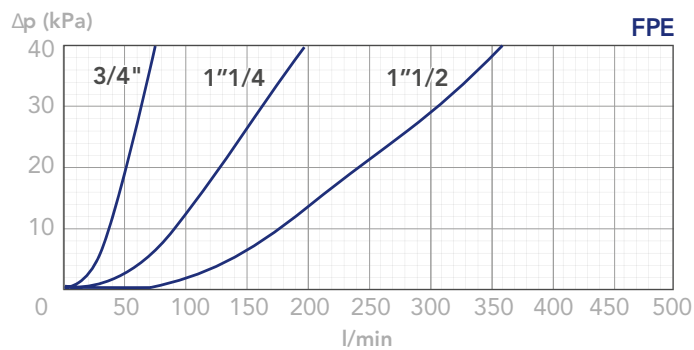



CLEAN FILTER ELEMENT PRESSURE DROP WITH F+ AND C+ MEDIA
 (depending both on the internal diameter of the element and on the filter media)

FPE3+ and FPE4+ filters use double element canisters. The Assembly Pressure Drop is therefore determined by adding the Housing Pressure Drop at the real flow rate and half the pressure drop of the ESE2+ element.

E.g. The pressure drop of a complete FPE31-----FC---- filter at a 60 l/min flow rate is obtained by adding the Housing Pressure Drop and half the ESE21NFC element pressure drop at 60 l/min.

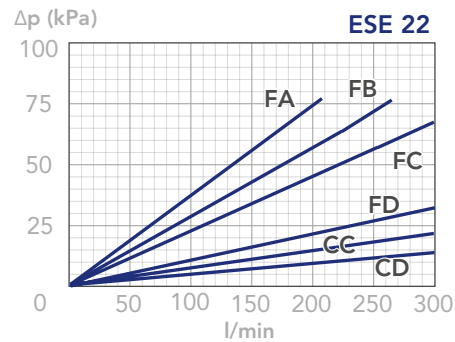
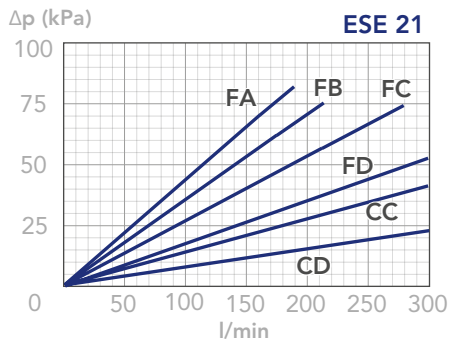
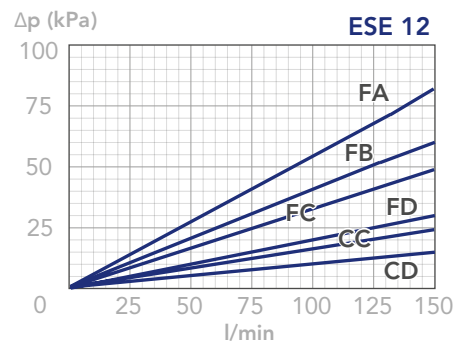
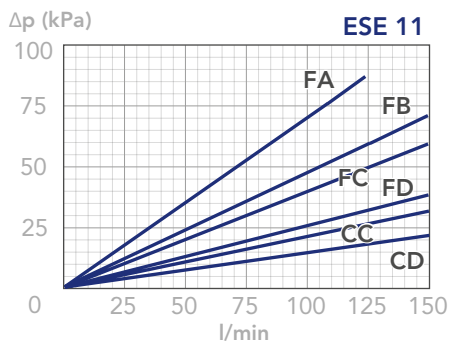

BYPASS VALVE PRESSURE DROP

When selecting the filter size, these curves must be taken into account if it is foreseen that any flow peak is to be absorbed by the bypass valve, it also must be of proper configuration to avoid pressure peaks. The valve pressure drop is directly proportional to fluid specific gravity.

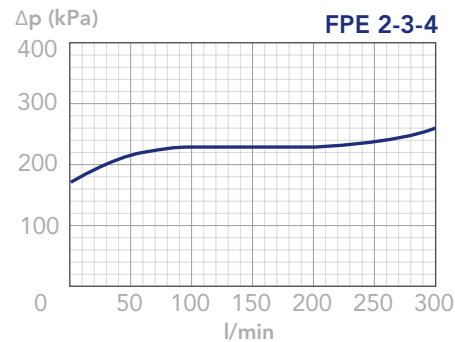
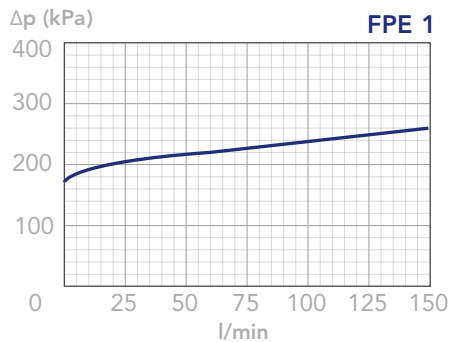

N.B.

All the curves have been obtained with mineral oil having a kinematic viscosity 30 cSt and specific gravity 0,86 kg/dm³; for fluids with different features, please consider the factors described in the first part of this catalogue. All the curves

are obtained from test done at the UFI FILTERS HYDRAULICS Laboratory, according to the specification ISO 3968. In case of discrepancy, please check the contamination level, viscosity and features of the fluid in use.



FPG

PRESSURE FILTERS



DESCRIPTION

Medium pressure filter

MATERIALS

Head: Aluminum alloy
Bowl: Steel
Bypass valve : Steel
Seals: NBR Nitrile (FKM Fluoroelastomer on request)
Indicator housing: Brass

PRESSURE

Max working: 5 MPa (50 bar)
Collapse, differential for the filter element:
1 MPa (10 bar)

BYPASS VALVE

Setting: 350 kPa (3,5 bar) $\pm 10\%$

FLOW RATE

Qmax 400 l/min

WORKING TEMPERATURE

From -25° to +110° C

COMPATIBILITY (ISO 2943)

Full with fluids: HH-HL-HM-HV-HTG
(according to ISO 6743/4)
For fluids different than the above mentioned,
please contact our Customer Service.



HYDRAULIC DIAGRAM

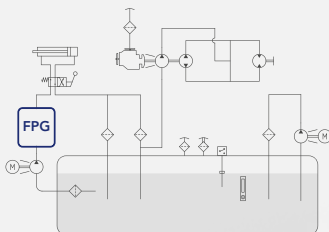

Is this datasheet the latest release? Please check on our website

FPG



PRESSURE FILTERS

ORDERING AND OPTION CHART

F	P	G	COMPLETE FILTER FAMILY					FILTER ELEMENT FAMILY	E	P	G
			SIZE & LENGTH	20	21	22	31	SIZE & LENGTH			
		B	PORT TYPE								
			B = BSP thread	B	B	B	B				
			PORT SIZE								
			06 = 3/4"	06	06	06	-				
			08 = 1"	08	08	08	-				
			10 = 1" 1/4	-	-	-	10				
			12 = 1" 1/2	-	-	-	12				
			BYPASS VALVE								
			W = without	W	W	W	W				
			D = 350 kPa (3,5 bar)	D	D	D	D				
			SEALS					SEALS			
			N = NBR Nitrile	N	N	N	N				
			F = FKM Fluoroelastomer	F	F	F	F				
			G = Treatment for water-glycol	G	G	G	G				
			FormulaUFI MEDIA					FormulaUFI MEDIA			
			FA = FormulaUFI.MICRON 5 $\mu\text{m}_{(c)}$ $\beta > 1.000$	FA	FA	FA	FA				
			FB = FormulaUFI.MICRON 7 $\mu\text{m}_{(c)}$ $\beta > 1.000$	FB	FB	FB	FB				
			FC = FormulaUFI.MICRON 12 $\mu\text{m}_{(c)}$ $\beta > 1.000$	FC	FC	FC	FC				
			FS = FormulaUFI.MICRON 16 $\mu\text{m}_{(c)}$ $\beta > 1.000$	FS	FS	FS	FS				
			FD = FormulaUFI.MICRON 21 $\mu\text{m}_{(c)}$ $\beta > 1.000$	FD	FD	FD	FD				
			FE = FormulaUFI.MICRON 30 $\mu\text{m}_{(c)}$ $\beta > 1.000$	FE	FE	FE	FE				
			MC = FormulaUFI.WEB 10 μm	MC	MC	MC	MC				
			MD = FormulaUFI.WEB 30 μm	MD	MD	MD	MD				
			ME = FormulaUFI.WEB 60 μm	ME	ME	ME	ME				
			MF = FormulaUFI.WEB 90 μm	MF	MF	MF	MF				
			CLOGGING INDICATOR**								
			00 = no indicator port	00	00	00	00				
			03 = port, plugged	03	03	03	03				
			5D = visual differential 250 kPa (2,5 bar)	5B	5B	5B	5B				
			6D = electrical differential 250 kPa (2,5 bar)	6B	6B	6B	6B				
			7D = indicator 6D with LED	7B	7B	7B	7B				
			T6 = elect. diff. 250 kPa (2,5 bar) with thermostat 30°C	T0	T0	T0	T0				
			ACCESSORI / ACCESSORIES								
			W = No indicator port	W	W	W	W				
			A = Indicator port side A (see dwg)	A	A	A	A				
			B = Indicator port side B (see dwg)	B	B	B	B				
			C = Indicator port side C (see dwg)	C	C	C	C				
		X	ACCESSORI / ACCESSORIES								
			X = no accessory available	X	X	X	X				

** When the filter is ordered with FKM seals, the first digit of the indicator code is a letter (please see Clogging Indicator Chapter for further details)

SPARE PARTS

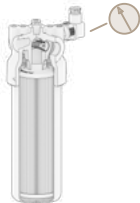
FILTER HOUSING				FILTER ELEMENT				CLOGGING INDICATOR			
											
B	P	G		E	P	G					



SPARE SEAL KIT

	NBR	FKM
FPG20-21-22	521.0117.2	521.0118.2
FPG31	521.0119.2	521.0120.2

INSTALLATION DRAWING

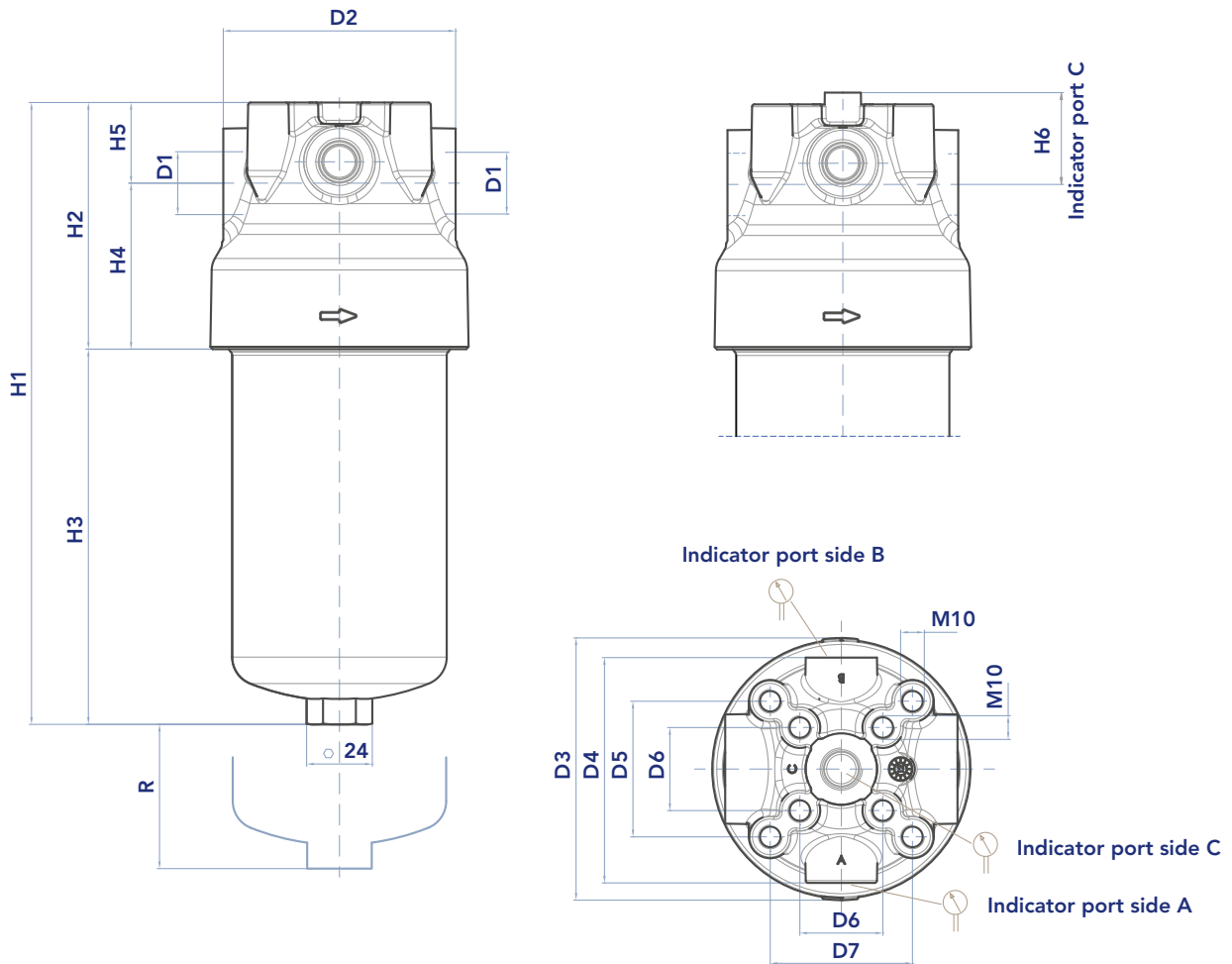

FILTER HOUSING

	D1	D2	D3	D4	D5	D6	D7	H1	H2	H3	H4	H5*	H6*	R	Kg
FPG20	3/4" - 1"	98	110,5	95	57	35	60	202	104	98	70	34	39	70	2,00
FPG21	3/4" - 1"	98	110,5	95	57	35	60	262	104	158	70	34	39	70	2,25
FPG22	3/4" - 1"	98	110,5	95	57	35	60	342	104	238	70	34	39	70	2,80
FPG31	1"1/4 - 1"1/2	122	126	115	70	48	70	335	116	219	77	39	44	70	3,50

* with clogging indicator option W, A and B, please consider H5; with clogging indicator option C, please consider H6

FPG

PRESSURE FILTERS

FILTER ELEMENT

	A	B	C	Kg	AREA (cm ²)		
					Media F+	Media F+	Media M+
EPG20	78	30	100	0,20	1.300	1.500	1.000
EPG21	78	30	160	0,30	2.200	2.550	1.700
EPG22	78	30	240	0,45	3.300	3.900	2.600
EPG31	92	40	220	0,45	4.700	5.100	3.500

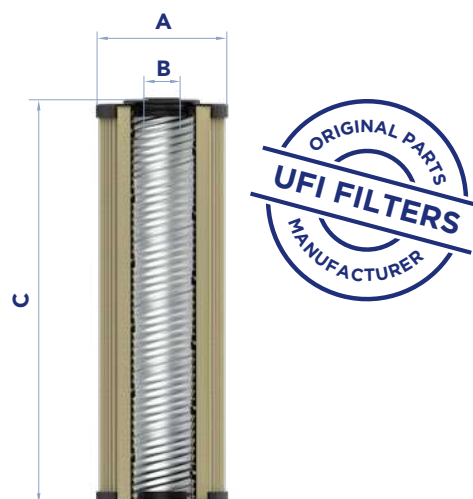

MAINTENANCE

- 1) Stop the system and verify there is no pressure in the filter.
- 2) Collect the oil inside the filter with a suitable container.
- 3) Unscrew the bowl (1) and clean it.
- 4) Remove the dirty filter element (2).
N.B. The exhausted filter elements and the oil dirty filter parts are classified "Dangerous waste material" and must be disposed of according to the local laws, by authorized Companies.
- 5) Check the filter element part number on the filter label or in the ordering and option chart.
N.B. The locking system is patented. Use only original spare parts.
- 6) Lubricate the element o-ring gasket (3) with oil.
- 7) Insert the clean element into its seat with care.
The element must be rotated clockwise on the shank to be in the correct locking position.
- 8) Check the bowl o-ring condition (4) and lubricate with oil.
If damaged, check the seal kit part number in the spare seal kit table
N.B. The anti-extrusion o-ring (5) must be positioned downwards (under the gasket).
- 9) Screw the bowl (1) until it stops, with a tightening torque of 70 Nm + 5/0.

Accessories:

Clogging indicator (6).

If damaged, unscrew and replace it (check the part number in the ordering and option chart).

Lubricate the o-ring gasket with oil and tighten until it stops, with a tightening torque of 40 Nm +5/0.

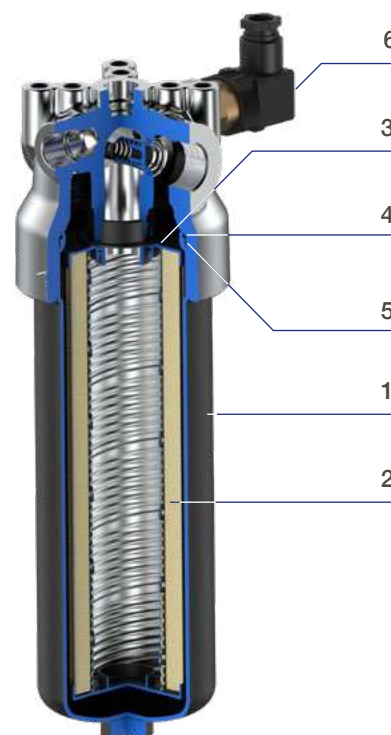



PRESSURE DROP CURVES (Δp)

The “Assembly Pressure Drop (Δp)” is obtained by adding the pressure drop values of the Filter Housing and of the Clean Filter Element corresponding to the considered Flow Rate and it must

be lower than 100 kPa (1 bar). In any case this value should never exceed 1/3 of the bypass valve setting.

FILTER HOUSING PRESSURE DROP
(mainly depending on the port size)

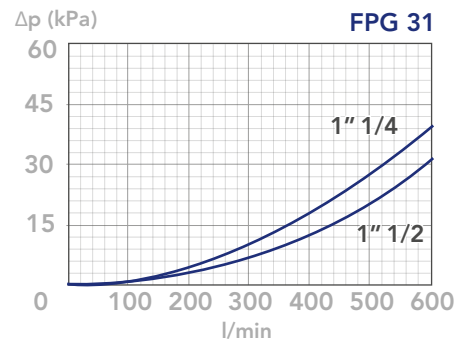
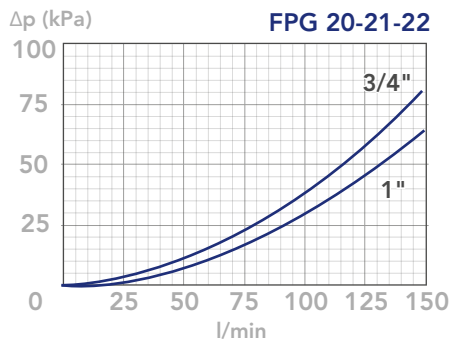

CLEAN FILTER ELEMENT PRESSURE DROP WITH F+ AND C+ MEDIA
(depending both on the internal diameter of the element and on the filter media)

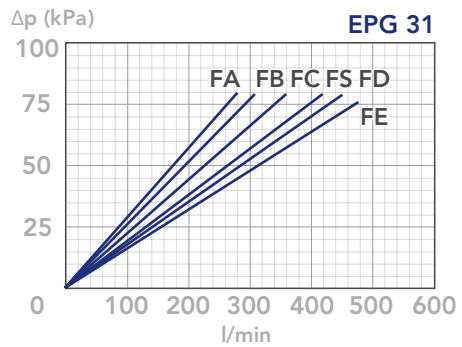
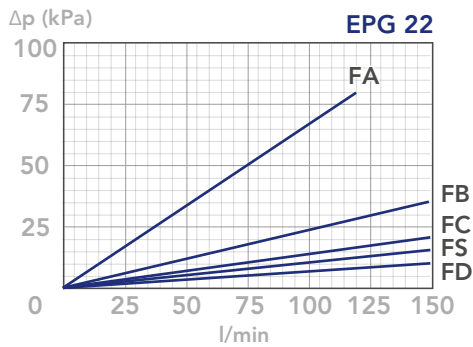
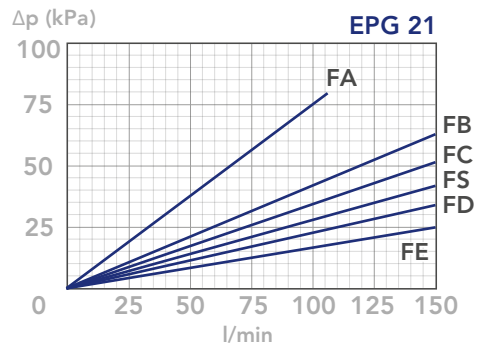
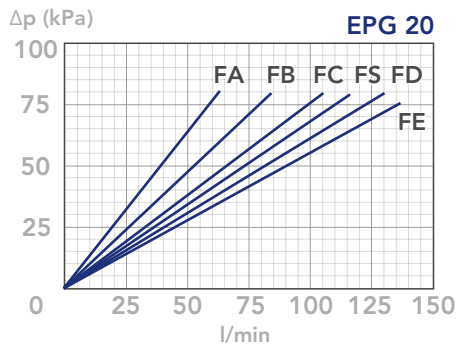

FPG

PRESSURE FILTERS



BYPASS VALVE PRESSURE DROP

When selecting the filter size, these curves must be taken into account if it is foreseen that any flow peak is to be absorbed by the bypass valve, it also must be of proper configuration to avoid pressure peaks. The valve pressure drop is directly proportional to fluid specific gravity.

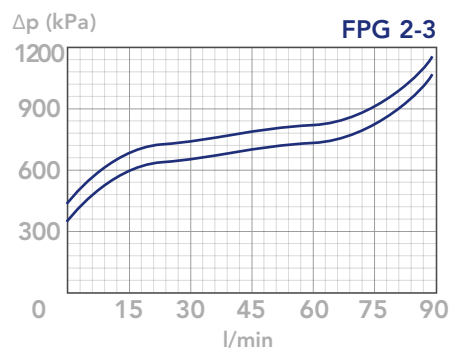

N.B.

All the curves have been obtained with mineral oil having a kinematic viscosity 30 cSt and specific gravity 0,86 kg/dm³; for fluids with different features, please consider the factors described in the first part of this catalogue. All the curves

are obtained from test done at the UFI FILTERS HYDRAULICS Laboratory, according to the specification ISO 3968. In case of discrepancy, please check the contamination level, viscosity and features of the fluid in use.



FPH

PRESSURE FILTERS

DESCRIPTION

3-way inline filter

MATERIALS

Head: Aluminum alloy
Bowl: Steel
Bypass valve: Polyamide
Seals: NBR Nitrile (FKM Fluoroelastomer on request)
Indicator housing: Brass

PRESSURE

Max working: 2 MPa (20 bar)
Collapse, differential for the filter element:
300 kPa (3 bar)

BYPASS VALVE

Setting: 170 kPa (1,7 bar) \pm 10%

FLOW RATE

Qmax 400 l/min

WORKING TEMPERATURE

From -25° to +110° C

COMPATIBILITY (ISO 2943)

Full with fluids: HH-HL-HM-HV-HTG
(according to ISO 6743/4)
For fluids different than the above mentioned,
please contact our Sales Department.

HYDRAULIC DIAGRAM

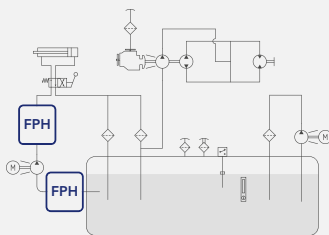

Is this datasheet the latest release? Please check on our website



FPH

PRESSURE FILTERS



ORDERING AND OPTION CHART

F	P	H	COMPLETE FILTER FAMILY					FILTER ELEMENT FAMILY	E	R	A
			SIZE & LENGTH	31	40	50	52	SIZE & LENGTH			
			PORT TYPE								
			B = BSP thread	B	B	B	B				
			N = NPT thread	N	N	N	N				
			PORT SIZE								
			03 = 3/8"	03	-	-	-				
			04 = 1/2"	04	-	-	-				
			06 = 3/4"	-	06	-	-				
			08 = 1"	-	08	-	-				
			10 = 1" 1/4	-	-	10					
			12 = 1" 1/2	-	-	-	12				
		B	BYPASS VALVE								
			B = 170 kPa (1,7 bar)	B	B	B	B				
			SEALS					SEALS			
			N = NBR Nitrile	N	N	N	N				
			F = FKM Fluoroelastomer	F	F	F	F				
			FormulaUFI MEDIA					FormulaUFI MEDIA			
			FA = FormulaUFI.MICRON 5 $\mu\text{m}_{(c)}$ $\beta > 1.000$	FA	FA	FA	FA				
			FB = FormulaUFI.MICRON 7 $\mu\text{m}_{(c)}$ $\beta > 1.000$	FB	FB	FB	FB				
			FC = FormulaUFI.MICRON 12 $\mu\text{m}_{(c)}$ $\beta > 1.000$	FC	FC	FC	FC				
			FS = FormulaUFI.MICRON 16 $\mu\text{m}_{(c)}$ $\beta > 1.000$	FS	FS	FS	FS				
			FD = FormulaUFI.MICRON 21 $\mu\text{m}_{(c)}$ $\beta > 1.000$	FD	FD	FD	FD				
			FE = FormulaUFI.MICRON 30 $\mu\text{m}_{(c)}$ $\beta > 1.000$	FE	FE	FE	FE				
			ME = FormulaUFI.WEB 60 μm	ME	ME	ME	ME				
			MF = FormulaUFI.WEB 90 μm	MF	MF	MF	MF				
			CLOGGING INDICATOR**								
			03 = port, plugged	03	03	03	03				
			5B = visual differential 130 kPa (1,3 bar)	5B	5B	5B	5B				
			6B = electrical differential 130 kPa (1,3 bar)	6B	6B	6B	6B				
			7B = indicator 6E with LED	7B	7B	7B	7B				
			T0 = elect. diff. 130 kPa (1,3 bar) with thermostat 30°C	T0	T0	T0	T0				
			0R = 1/8" predisposition	0R	0R	0R	0R				
			31 = pressure gauge, rear connection	31	31	31	31				
			P1 = SPDT, pressure switch	P1	P1	P1	P1				
			10 = vacuum gauge	10	10	10	10				
			91 = vacuum switch	91	91	91	91				
X	X		ACCESSORI / ACCESSORIES								
			XX = no accessory available	XX	XX	XX	XX				

** When the filter is ordered with FKM seals, the first digit of the indicator code is a letter (please see Clogging Indicator Chapter for further details)

SPARE PARTS

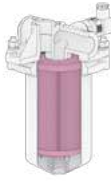
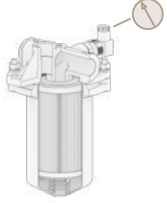
FILTER HOUSING					FILTER ELEMENT					CLOGGING INDICATOR						
																
B	P	H			B					E	R	A				

SPARE SEAL KIT

NBR		FKM		NBR		FKM		NBR		FKM		
FPH31	521.0006.2	521.0075.2			FPH40	521.0007.2	521.0076.2			FPH50-52	521.0008.2	521.0077.2

INSTALLATION DRAWING

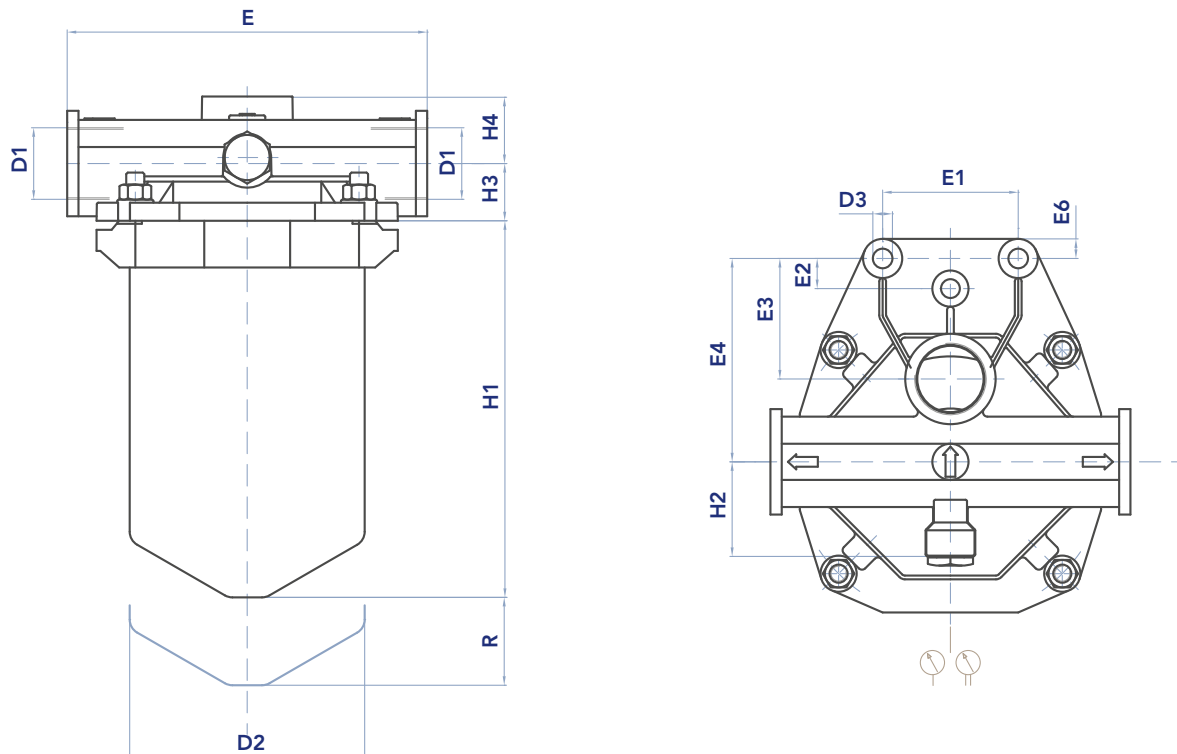

FILTER HOUSING

	D1	D2	D3	E	E1	E2	E3	E4	E6	H1	H2	H3	H4	R	kg
FPH31	3/8" - 1/2"	81	11	114	50	-	42	70	10	114	44	19	27	20	1,3
FPH40	3/4" - 1"	114	13	150	50	-	50	85	13	212	58	30	35	20	3,2
FPH50	1"1/4	156	13	240	90	20	80	135	13	200	62	38	45	25	6,1
FPH52	1"1/2	156	13	240	90	20	80	135	13	265	62	38	45	25	6,8

FPH

PRESSURE FILTERS



FILTER ELEMENT

	AREA (cm ²)			Kg	Media F+	Media M+
	A	B	C			
ERA31	70	28	85	0,20	620	990
ERA40	99	40	170	0,60	3.630	3.390
ERA50	130	63	140	1,00	4.450	4.360
ERA52	130	63	200	1,35	6.190	6.520

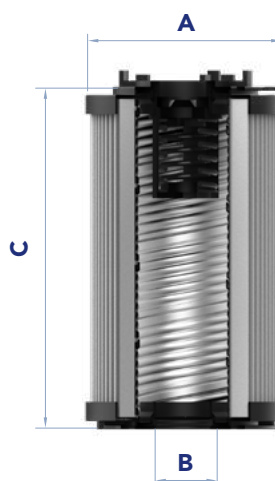

MAINTENANCE

- 1) Stop the system and verify there is no pressure in the filter.
- 2) Collect the oil inside the filter with a suitable container.
- 3) Unscrew the nuts (1) to disassemble the flange (2) from the bowl (3) positioned below the head (4). N.B. The bowl is in contact only with the flange.
- 4) Empty and clean the bowl (3). Make sure the gasket (5) and the spring (6) remain on the bottom of the bowl. These parts have to be reused.
- 5) Remove the dirty filter element (7).
N.B. The exhausted filter elements and the oil dirty filter parts are classified "Dangerous waste material" and must be disposed of according to the local laws, by authorized Companies.
- 6) Check the filter element part number on the filter label or in the ordering and option chart.
Use only original spare parts.
- 7) Lubricate the element o-ring gasket (8) with oil.
- 8) Insert the clean element into its seat with care.
- 9) Fit the bowl into the flange and place the flat gasket. The spring must be centred on the bottom of the bowl.
- 10) Place the flange against the head, centering the 4 threaded pins.
- 11) Screw manually a nut and its washer (1) onto the stud without locking. Repeat the same operation with the opposite nut, and then with the remaining two.
- 12) Tighten all nuts gradually with the cross system until the bowl is completely locked, to ensure the correct adhesion between the container and the head.

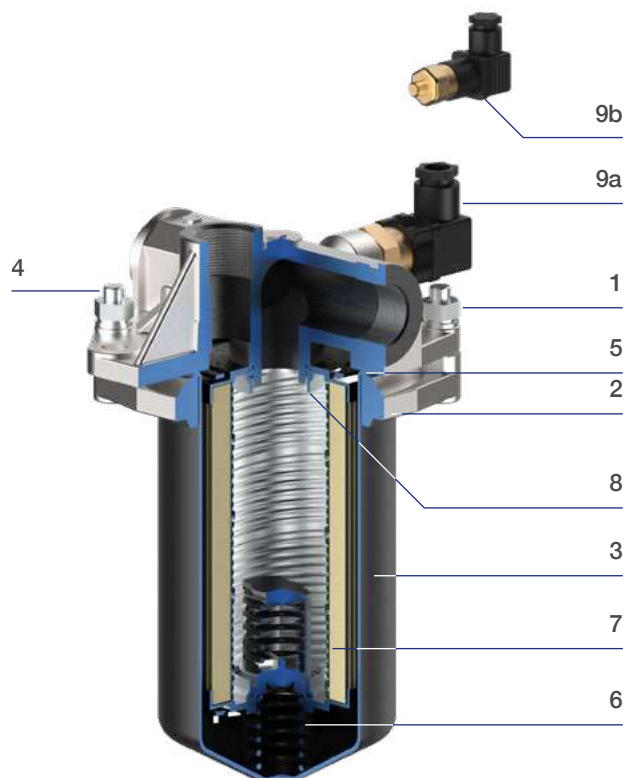

- a) Differential clogging indicator with metric thread connection (9a). Lubricate the o-ring gaskets with oil and screw until stop, with a tightening torque of 40 Nm +5/0.
- b) Clogging indicator with 1/8" thread connection (9b). Apply a thread-sealing and screw until tight. An over-tightening can damage the thread.

Accessories:

Clogging indicator (9).

If damaged, unscrew and replace it (check the part number in the ordering and option chart). Follow the instruction (a) or (b) according to the type of indicator in use.

PRESSURE DROP CURVES (Δp)

The "Assembly Pressure Drop (Δp)" is obtained by adding the pressure drop values of the Filter Housing and of the Clean Filter Element corresponding to the considered Flow Rate and it must

be lower than 50 kPa (0,5 bar). In any case this value should never exceed 1/3 of the bypass setting.

FILTER HOUSING PRESSURE DROP
(mainly depending on the port size)

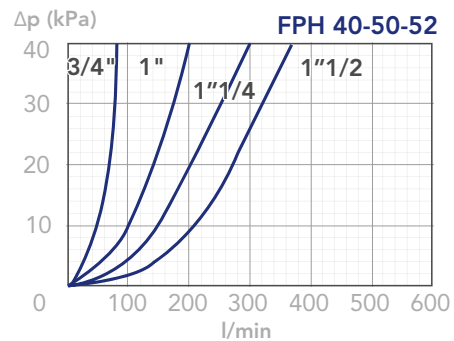
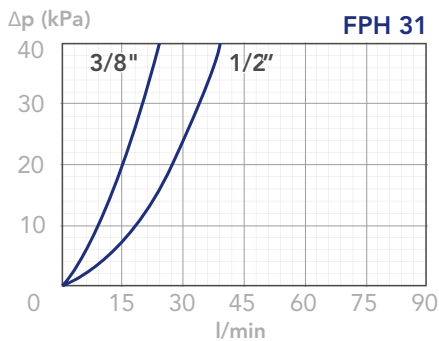

CLEAN FILTER ELEMENT PRESSURE DROP WITH F+ AND M+ MEDIA
(depending both on the internal diameter of the element and on the filter media)

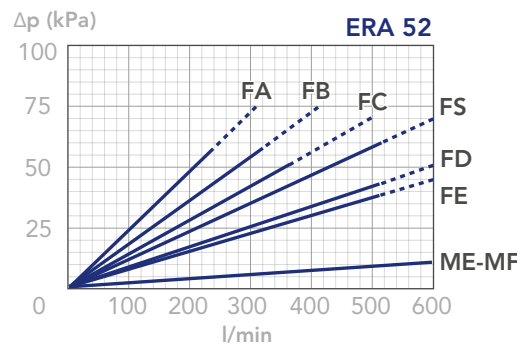
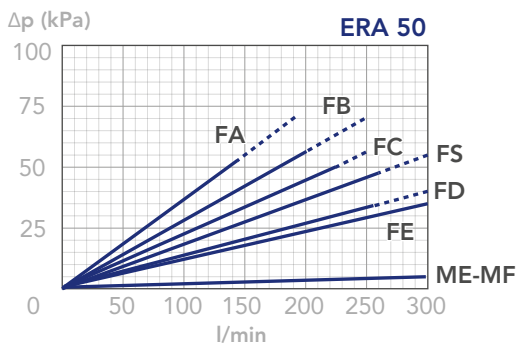
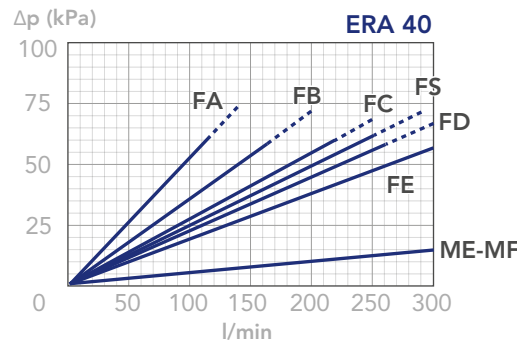
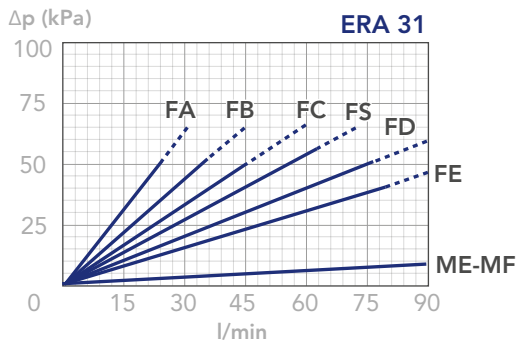

FPH

PRESSURE FILTERS



BYPASS VALVE PRESSURE DROP

When selecting the filter size, these curves must be taken into account if it is foreseen that any flow peak is to be absorbed by the bypass valve, it also must be of proper configuration to avoid pressure peaks. The valve pressure drop is directly proportional to fluid specific gravity.

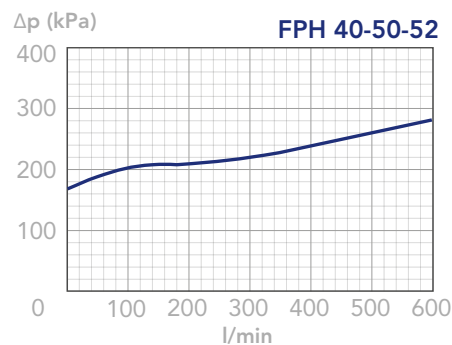
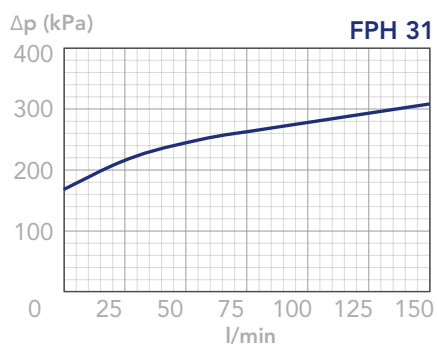

N.B.

All the curves have been obtained with mineral oil having a kinematic viscosity 30 cSt and specific gravity 0,9 kg/dm³; for fluids with different features, please consider the factors described in the first part of this catalogue. All the curves are

obtained from test done at the UFI FILTERS HYDRAULICS Laboratory, according to the specification ISO 3968:2005. In case of discrepancy, please check the contamination level, viscosity and features of the fluid in use.



FPL

PRESSURE FILTERS



DESCRIPTION

Pressure filter manifold side mounting

MATERIALS

Head: Cast iron

Bowl: Steel

Bypass valve: Steel

Seals: NBR Nitrile (FKM Fluoroelastomer on request)

Indicator housing: Brass

PRESSURE

Max. working: 31,5 MPa (315 bar)

Collapse, differential for the filter element
standard series: 2 MPa (20 bar)

H+ series: 21 MPa (210 bar)

BYPASS VALVE

Setting: 600 kPa (6 bar) \pm 10%

FLOW RATE

Qmax 400 l/min

WORKING TEMPERATURE

From -25° to +110° C

COMPATIBILITY (ISO 2943)

Full with fluids: HH-HL-HM-HV-HTG

(according to ISO 6743/4)

For fluids different than the above mentioned,
please contact our Customer Service



HYDRAULIC DIAGRAM

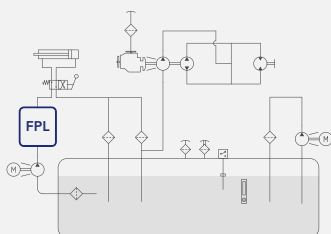

Is this datasheet the latest release? Please check on our website

FPL

PRESSURE FILTERS



ORDERING AND OPTION CHART

F	P	L	COMPLETE FILTER FAMILY												FILTER ELEMENT FAMILY			E	P	B
			SIZE & LENGTH	11	12	13	21	22	31	32	33	34	35	SIZE & LENGTH						
			PORT TYPE																	
			C = Flanges 90° (manifold)	C	C	C	C	C	C	C	C	C	C	C	C	C	C			
			PORT SIZE																	
			15 = size 15	15	15	15	-	-	-	-	-	-	-	-	-	-	-			
			20 = size 20	-	-	-	20	20	-	-	-	-	-	-	-	-	-			
			32 = size 32	-	-	-	-	-	32	32	32	32	32	32	32	32	32			
			BYPASS VALVE																	
			W = without	W	W	W	W	W	W	W	W	W	W	W	W	W	W			
			C = 600 kPa (6 bar)	C	C	C	C	C	C	C	C	C	C	C	C	C				
			SEALS												SEALS					
			N = NBR Nitrile	N	N	N	N	N	N	N	N	N	N	N	N	N	N			
			F = FKM Fluoroelastomer	F	F	F	F	F	F	F	F	F	F	F	F	F				
			FormulaUFI MEDIA												FormulaUFI MEDIA					
			FA = FormulaUFI.MICRON 5 $\mu\text{m}_{(c)}$ $\beta > 1.000 \Delta p$ 2MPa (20 bar)	FA	FA	FA	FA	FA	FA	FA	FA	FA	FA	FA	FA	FA				
			FB = FormulaUFI.MICRON 7 $\mu\text{m}_{(c)}$ $\beta > 1.000 \Delta p$ 2MPa (20 bar)	FB	FB	FB	FB	FB	FB	FB	FB	FB	FB	FB	FB	FB				
			FC = FormulaUFI.MICRON 12 $\mu\text{m}_{(c)}$ $\beta > 1.000 \Delta p$ 2MPa (20 bar)	FC	FC	FC	FC	FC	FC	FC	FC	FC	FC	FC	FC	FC				
			FS = FormulaUFI.MICRON 16 $\mu\text{m}_{(c)}$ $\beta > 1.000 \Delta p$ 2MPa (20 bar)	FS	FS	FS	FS	FS	FS	FS	FS	FS	FS	FS	FS	FS				
			FD = FormulaUFI.MICRON 21 $\mu\text{m}_{(c)}$ $\beta > 1.000 \Delta p$ 2MPa (20 bar)	FD	FD	FD	FD	FD	FD	FD	FD	FD	FD	FD	FD	FD				
			FE = FormulaUFI.MICRON 30 $\mu\text{m}_{(c)}$ $\beta > 1.000 \Delta p$ 2MPa (20 bar)	FE	FE	FE	FE	FE	FE	FE	FE	FE	FE	FE	FE	FE				
			HA = FormulaUFI.MICRON 5 $\mu\text{m}_{(c)}$ $\beta > 1.000 \Delta p$ 21MPa (210 bar)	HA	HA	HA	HA	HA	HA	HA	HA	HA	HA	HA	HA	HA				
			HB = FormulaUFI.MICRON 7 $\mu\text{m}_{(c)}$ $\beta > 1.000 \Delta p$ 21MPa (210 bar)	HB	HB	HB	HB	HB	HB	HB	HB	HB	HB	HB	HB	HB				
			HC = FormulaUFI.MICRON 12 $\mu\text{m}_{(c)}$ $\beta > 1.000 \Delta p$ 21MPa (210 bar)	HC	HC	HC	HC	HC	HC	HC	HC	HC	HC	HC	HC	HC				
			HD = FormulaUFI.MICRON 21 $\mu\text{m}_{(c)}$ $\beta > 1.000 \Delta p$ 21MPa (210 bar)	HD	HD	HD	HD	HD	HD	HD	HD	HD	HD	HD	HD	HD				
			CLOGGING INDICATOR**																	
			03 = port, plugged	03	03	03	03	03	03	03	03	03	03	03	03	03				
			5E = visual differential 500 kPa (5 bar)	5E	5E	5E	5E	5E	5E	5E	5E	5E	5E	5E	5E	5E				
			5F = visual differential 800 kPa (8 bar)	5F	5F	5F	5F	5F	5F	5F	5F	5F	5F	5F	5F	5F				
			6E = electrical differential 500 kPa (5 bar)	6E	6E	6E	6E	6E	6E	6E	6E	6E	6E	6E	6E	6E				
			6F = electrical differential 800 kPa (8 bar)	6F	6F	6F	6F	6F	6F	6F	6F	6F	6F	6F	6F	6F				
			7E = indicator 6E with LED	7E	7E	7E	7E	7E	7E	7E	7E	7E	7E	7E	7E	7E				
			7F = indicator 6F with LED	7F	7F	7F	7F	7F	7F	7F	7F	7F	7F	7F	7F	7F				
			T2 = elect. diff. 500 kPa (5 bar) with thermostat 30°C	T2	T2	T2	T2	T2	T2	T2	T2	T2	T2	T2	T2	T2				
			T3 = elect. diff. 800 kPa (8 bar) with thermostat 30°C	T3	T3	T3	T3	T3	T3	T3	T3	T3	T3	T3	T3	T3				
X	X		ACCESSORI / ACCESSORIES																	
			XX = no accessory available	XX	XX	XX	XX	XX	XX	XX	XX	XX	XX	XX	XX	XX				

** When the filter is ordered with FKM seals, the first digit of the indicator code is a letter (please see Clogging Indicator Chapter for further details)

SPARE PARTS

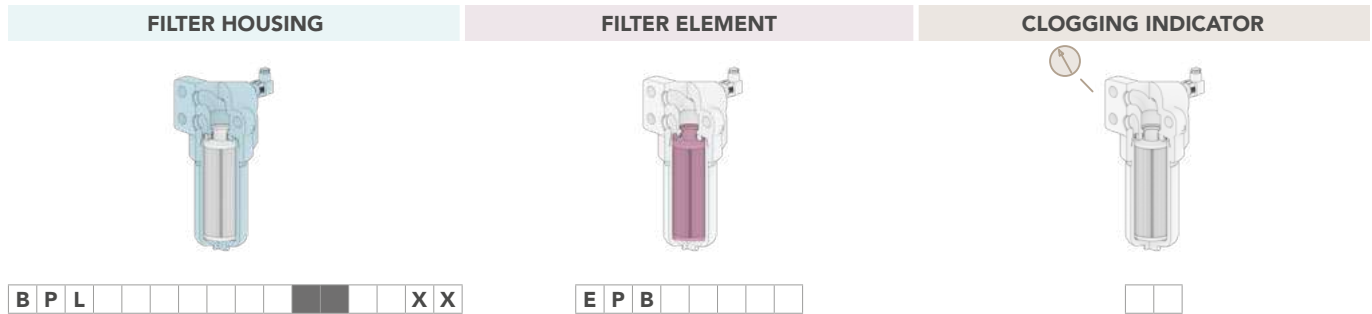

SPARE SEAL KIT

	NBR	FKM		NBR	FKM
FPL11-12-13	521.0080.2	521.0083.2	FPL31-32-33-34-35	521.0082.2	521.0085.2
FPL21-22	521.0081.2	521.0084.2			

INSTALLATION DRAWING

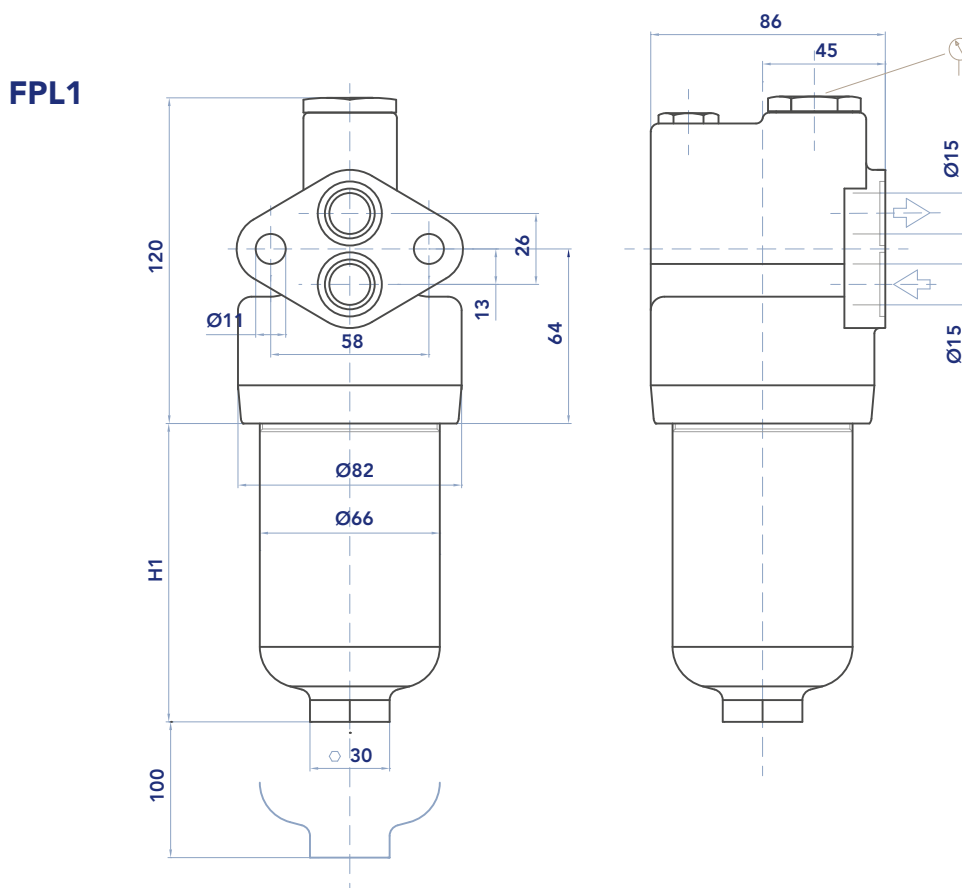

FILTER HOUSING

	H1	Kg
FPL11	75	4,4
FPL12	107	4,6
FPL13	201	5,2

FPL

PRESSURE FILTERS

INSTALLATION DRAWING

FPL2

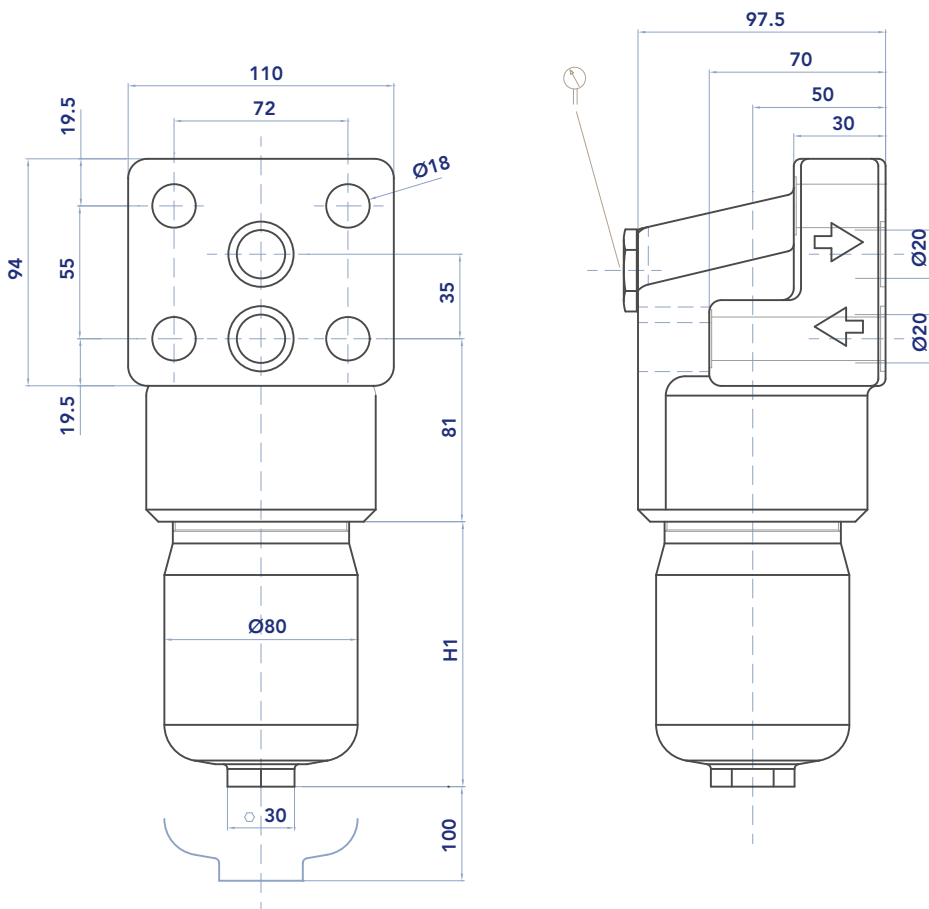

FILTER HOUSING

	H1	Kg
FPL21	107	6,6
FPL22	202	8,2



INSTALLATION DRAWING

FPL 31-32-33

FPL 34-35

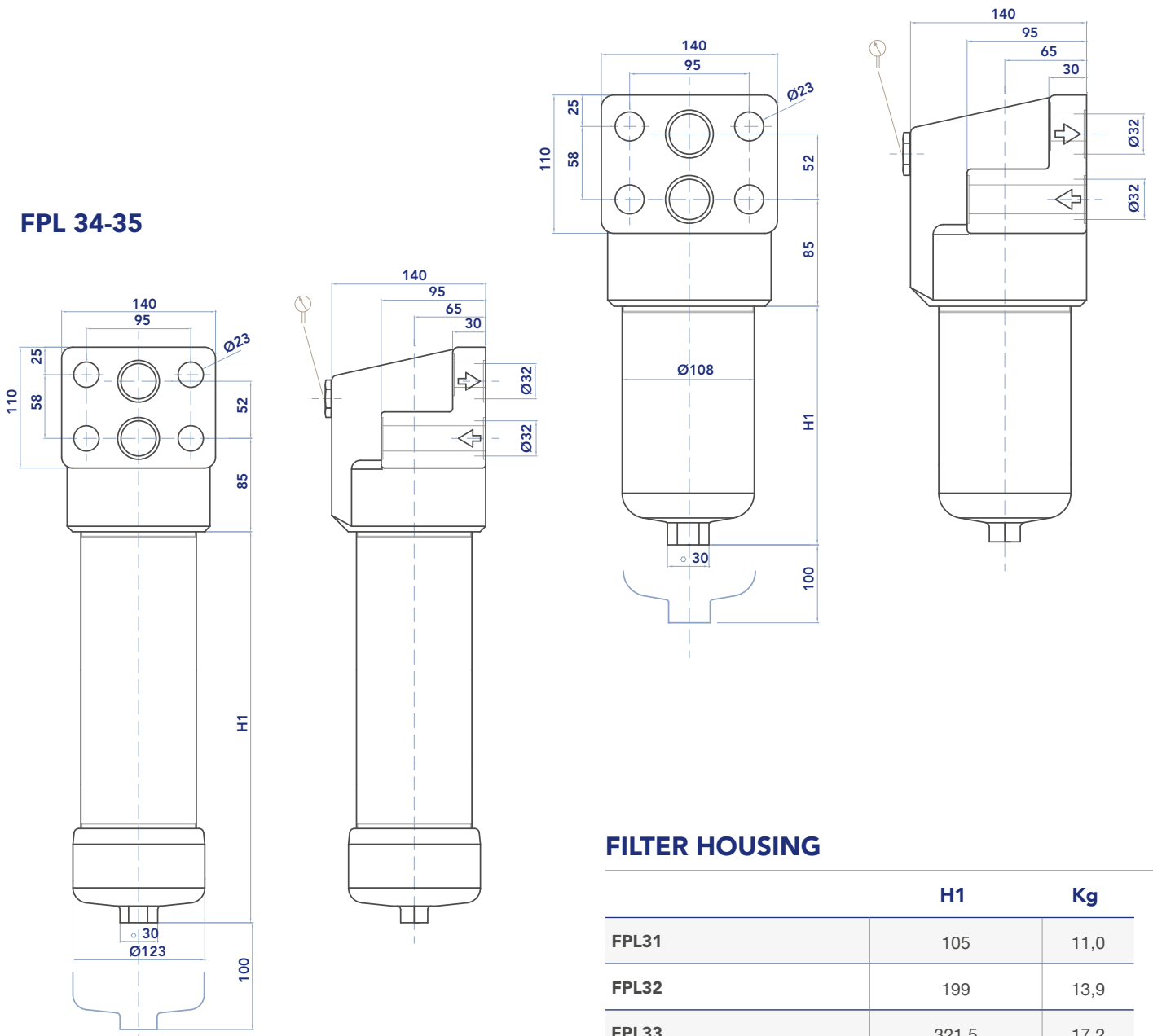

FILTER HOUSING

	H1	Kg
FPL31	105	11,0
FPL32	199	13,9
FPL33	321,5	17,2
FPL34	420	22,0
FPL35	520	25,0

FPL

PRESSURE FILTERS

FILTER ELEMENT

	A	B	C	Kg	Kg	AREA (cm ²)	
				Media F	Media H	Media F+	Media H+
EPB11	45	25	85	0,15	0,25	355	340
EPB12	45	25	116	0,20	0,55	500	475
EPB13	45	25	211	0,30	0,45	935	915
EPB21	52	23,5	115	0,25	0,40	975	975
EPB22	52	23,5	210	0,35	0,55	1.830	1.785
EPB31	78	42,5	118	0,40	0,70	2.000	1.470
EPB32	78	42,5	210	0,80	1,30	3.695	2.695
EPB33	78	42,5	330	1,00	1,60	5.025	4.325
EPB34	78	42,5	430	1,20	1,80	6.585	5.685
EPB35	78	42,5	530	1,40	2,00	8.145	7.045

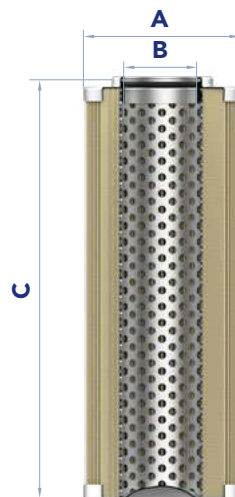

MAINTENANCE

- 1) Stop the system and verify there is no pressure in the filter.
- 2) Collect the oil inside the filter with a suitable container.
- 3) Unscrew the bowl (1) and clean it.
- 4) Remove the dirty filter element (2).
N.B. The exhausted filter elements and the oil dirty filter parts are classified "Dangerous waste material" and must be disposed of according to the local laws, by authorized Companies.
- 5) Check the filter element part number on the filter label or in the ordering and option chart.
Use only original spare parts.
- 6) Lubricate the element o-ring gasket (3) with oil.
- 7) Insert the clean element into its seat with care.
- 8) Check the bowl o-ring condition (4) and lubricate with oil. If damaged, check the seal kit part number in the spare seal kit table.
N.B. The anti-extrusion o-ring (5) must be positioned downwards (under the gasket).
- 9) Screw the bowl (1) until it stops, with a tightening torque of 70 Nm + 5/0.

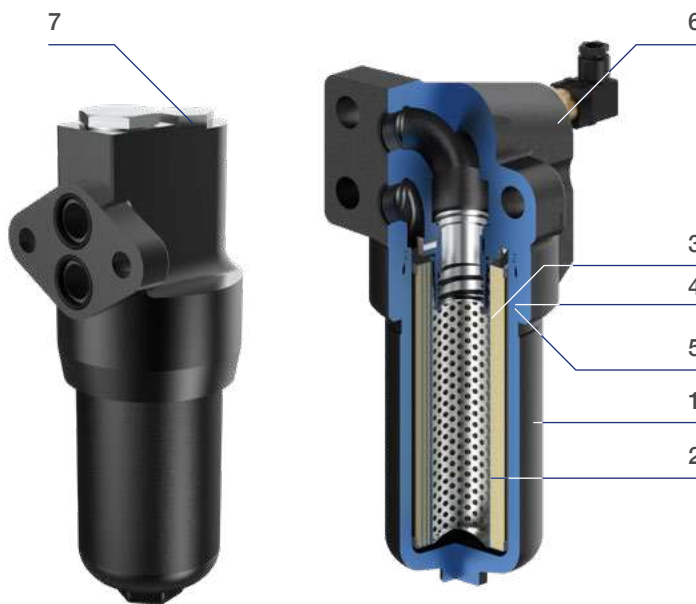

Accessories:

Clogging indicator (6)

If damaged, unscrew and replace it (check the part number in the ordering and option chart).

Lubricate the o-ring gasket with oil and tighten until it stops, with a tightening torque of 40 Nm +5/0.



PRESSURE DROP CURVES (Δp)

The “Assembly Pressure Drop (Δp)” is obtained by adding the pressure drop values of the Filter Housing and of the Clean Filter Element corresponding to the considered Flow Rate and it must be

lower than 120 kPa (1,2 bar). In any case this value should never exceed 1/3 of the bypass setting.

FILTER HOUSING PRESSURE DROP
(mainly depending on the port size)

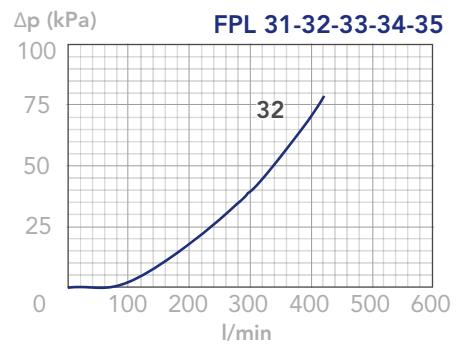
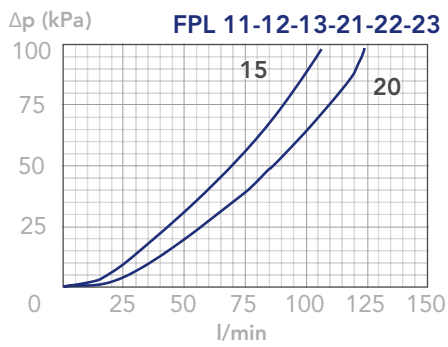

CLEAN FILTER ELEMENT PRESSURE DROP WITH F+ MEDIA
(depending both on the internal diameter of the element and on the filter media)

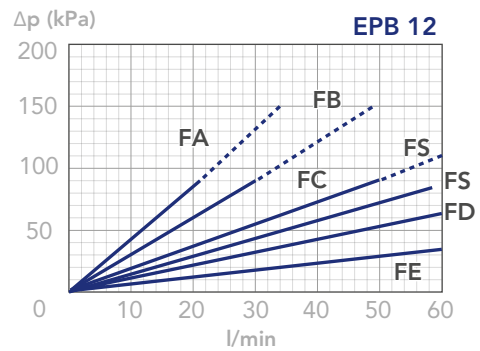
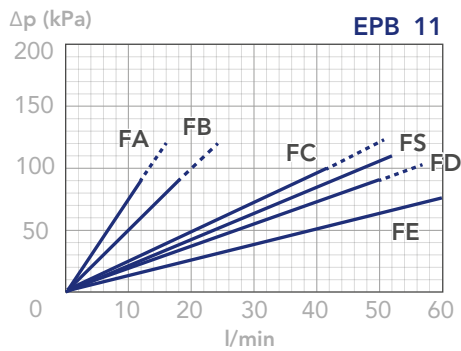

FPL

PRESSURE FILTERS

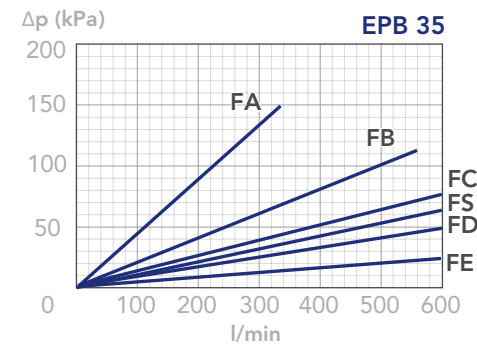
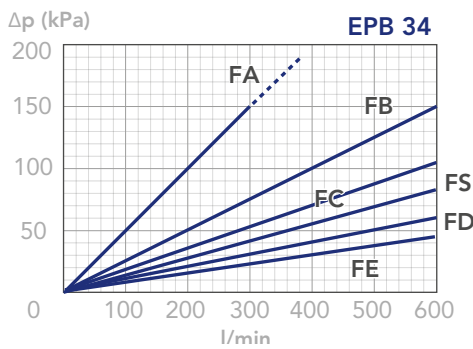
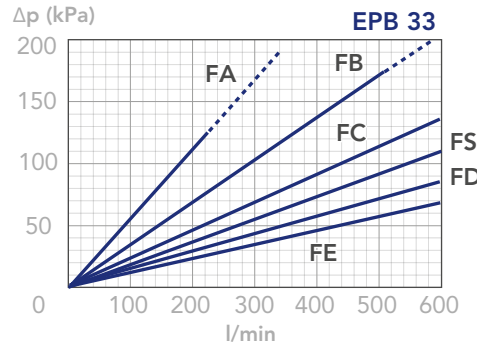
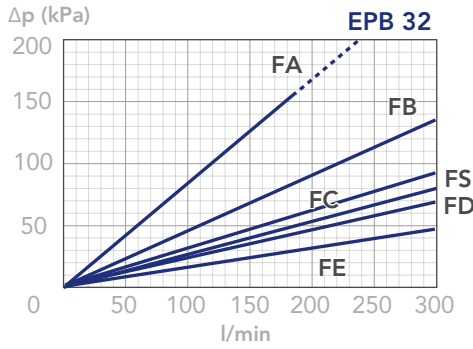
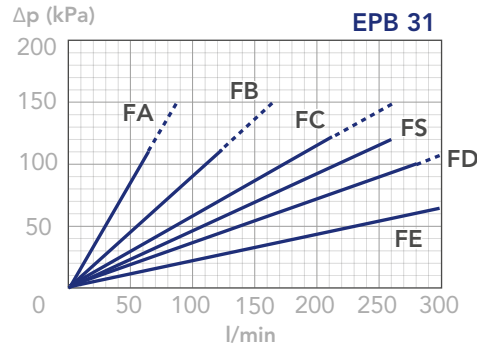
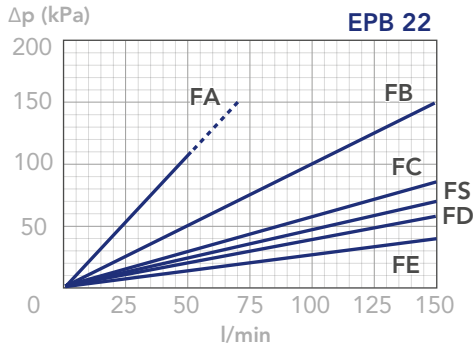
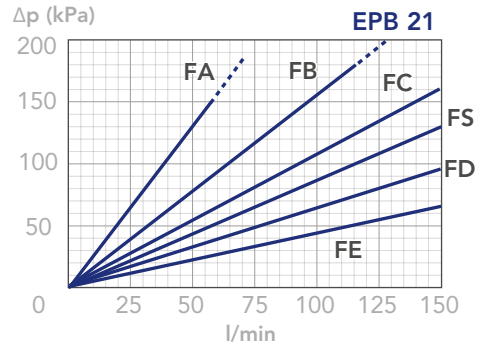
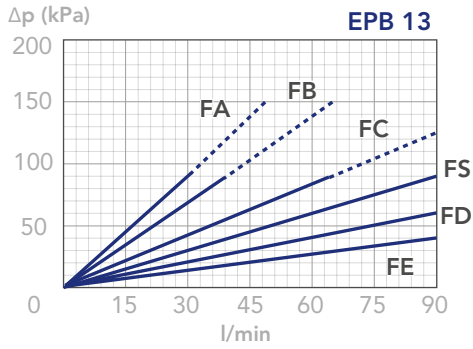

N.B.

All the curves have been obtained with mineral oil having a kinematic viscosity 30 cSt and specific gravity 0,86 kg/dm³; for fluids with different features, please consider the factors described in the first part of this catalogue. All the curves

are obtained from test done at the UFI FILTERS HYDRAULICS Laboratory, according to the specification ISO 3968. In case of discrepancy, please check the contamination level, viscosity and features of the fluid in use.



PRESSURE DROP CURVES (Δp)

CLEAN FILTER ELEMENT PRESSURE DROP WITH H+ MEDIA

depending both on the internal diameter of the element and on the filter media) - Recommended with no bypass option

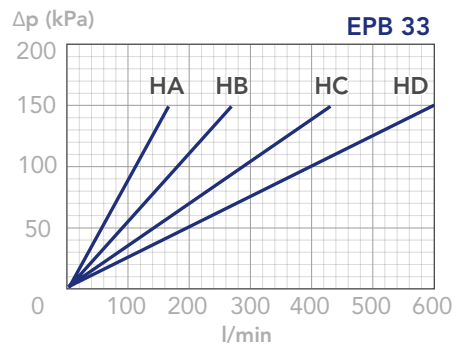
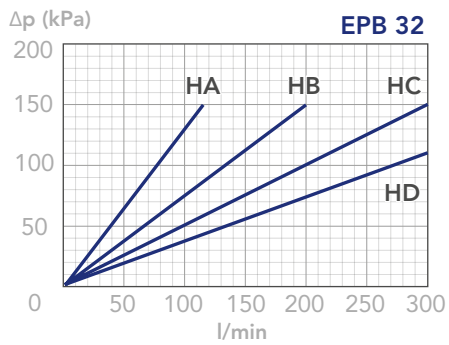
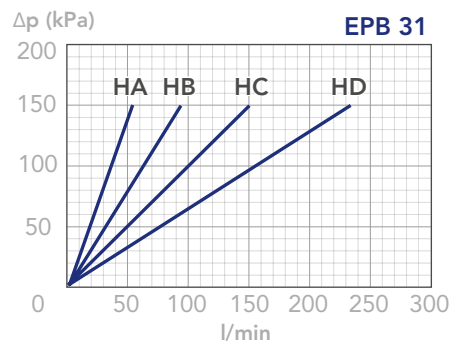
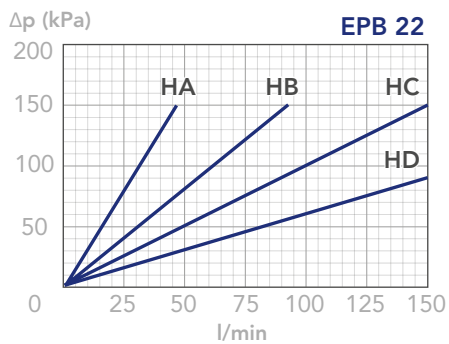
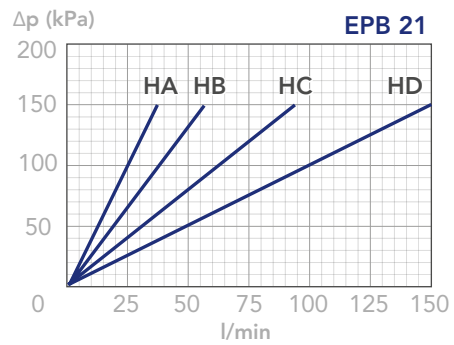
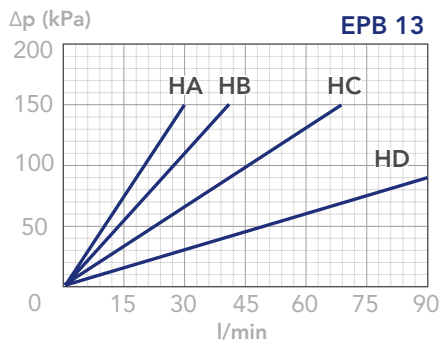
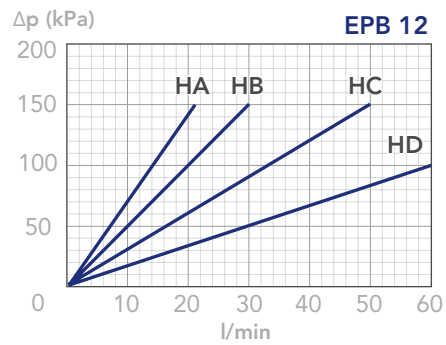
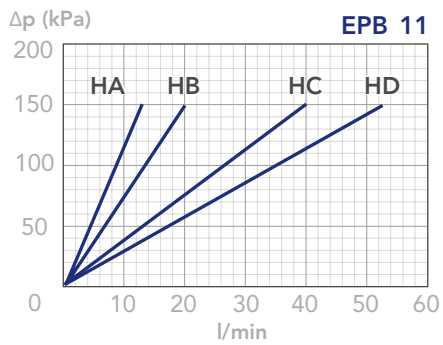

FPL

PRESSURE FILTERS

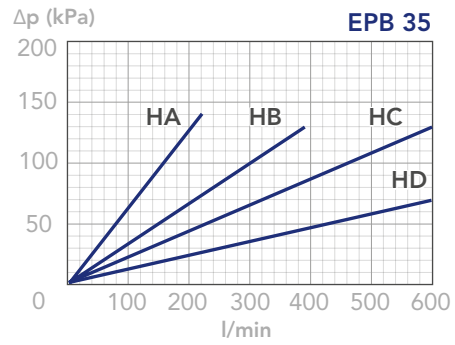
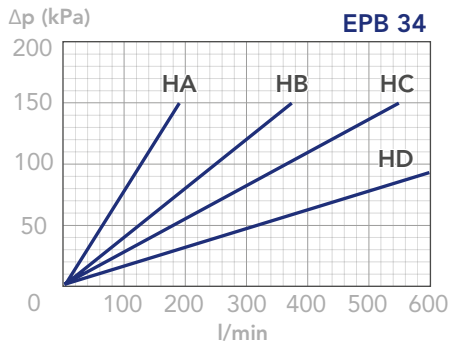

BYPASS VALVE PRESSURE DROP

When selecting the filter size, these curves must be taken into account if it is foreseen that any flow peak is to be absorbed by the bypass valve, it also must be of proper configuration to avoid pressure peaks. The valve pressure drop is directly proportional to fluid specific gravity.

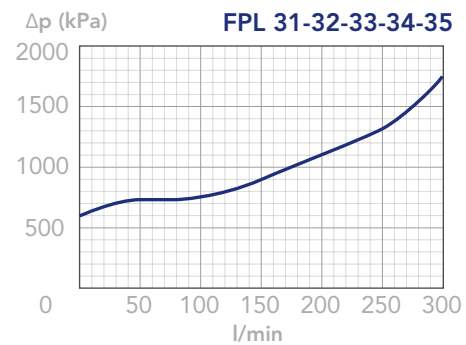
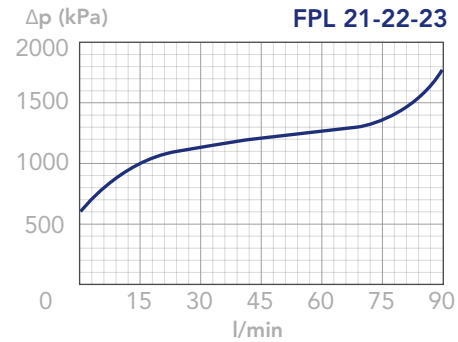
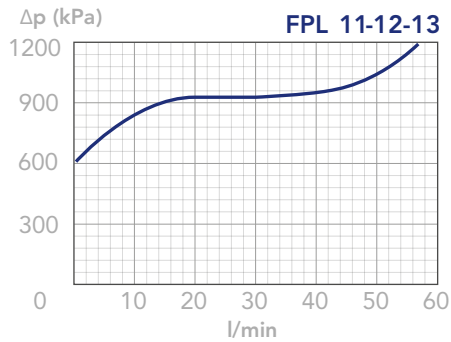

N.B.

All the curves have been obtained with mineral oil having a kinematic viscosity 30 cSt and specific gravity 0,86 kg/dm³; for fluids with different features, please consider the factors described in the first part of this catalogue. All the curves

are obtained from test done at the UFI FILTERS HYDRAULICS Laboratory, according to the specification ISO 3968. In case of discrepancy, please check the contamination level, viscosity and features of the fluid in use.



FPM

PRESSURE FILTERS

DESCRIPTION

Medium pressure inline filter

MATERIALS

Housing: Anodized aluminum alloy
Bypass valve: Steel
Seals: NBR Nitrile (FKM Fluoroelastomer on request)
Indicator housing: Brass

PRESSURE

Max. working: 21 MPa (210 bar)
Collapse, differential for the filter element:
2,1 MPa (21 bar)

BYPASS VALVE

Setting: 600 kPa (6 bar) \pm 10%

FLOW RATE

Qmax 120 l/min

WORKING TEMPERATURE

From -25° to +110° C

COMPATIBILITY (ISO 2943)

Full with fluids: HH-HL-HM-HV-HTG
(according to ISO 6743/4)
For fluids different than the above mentioned,
please contact our Customer Service



HYDRAULIC DIAGRAM

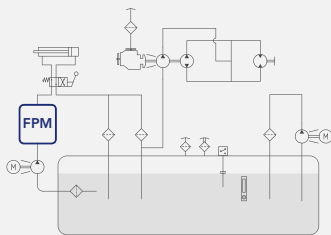

Is this datasheet the latest release? Please check on our website

FPM

PRESSURE FILTERS





ORDERING AND OPTION CHART

F	P	M	COMPLETE FILTER FAMILY			FILTER ELEMENT FAMILY	E	P	B
			SIZE & LENGTH	21	22	SIZE & LENGTH			
			PORT TYPE						
			B = BSP thread	B	B				
			N = NPT thread	N	N				
			S = SAE thread	S	S				
			PORT SIZE						
			04 = 1/2" (N04 not available)	04	04				
			06 = 3/4"	06	06				
			08 = 1"	08	08				
			BYPASS VALVE						
			W = without	W	W				
			C = 600 kPa (6 bar)	C	C				
			SEALS			SEALS			
			N = NBR Nitrile	N	N				
			F = FKM Fluoroelastomer	F	F				
			FormulaUFI MEDIA			FormulaUFI MEDIA			
			FA = FormulaUFI.MICRON 5 $\mu\text{m}_{(c)}$ $\beta > 1.000$	FA	FA				
			FB = FormulaUFI.MICRON 7 $\mu\text{m}_{(c)}$ $\beta > 1.000$	FB	FB				
			FC = FormulaUFI.MICRON 12 $\mu\text{m}_{(c)}$ $\beta > 1.000$	FC	FC				
			FS = FormulaUFI.MICRON 16 $\mu\text{m}_{(c)}$ $\beta > 1.000$	FS	FS				
			FD = FormulaUFI.MICRON 21 $\mu\text{m}_{(c)}$ $\beta > 1.000$	FD	FD				
			FE = FormulaUFI.MICRON 30 $\mu\text{m}_{(c)}$ $\beta > 1.000$	FE	FE				
			CLOGGING INDICATOR**						
			03 = port, plugged	03	03				
			5E = visual differential 500 kPa (5 bar)	5E	5E				
			6E = electrical differential 500 kPa (5 bar)	6E	6E				
			7E = indicator 6E with LED	7E	7E				
			T2 = elect. diff. 500 kPa (5 bar) with thermostat 30°C	T2	T2				
X	X		ACCESSORI / ACCESSORIES						
			XX = no accessory available	XX	XX				

**When the filter is ordered with FKM seals, the first digit of the indicator code is a letter (please see Clogging Indicator Chapter for further details)

SPARE PARTS

FILTER HOUSING										FILTER ELEMENT					CLOGGING INDICATOR		
																	
B	P	M								E	P	B					

SPARE SEAL KIT

	NBR	FKM
FPM21-22	521.0011.2	521.0010.2

INSTALLATION DRAWING

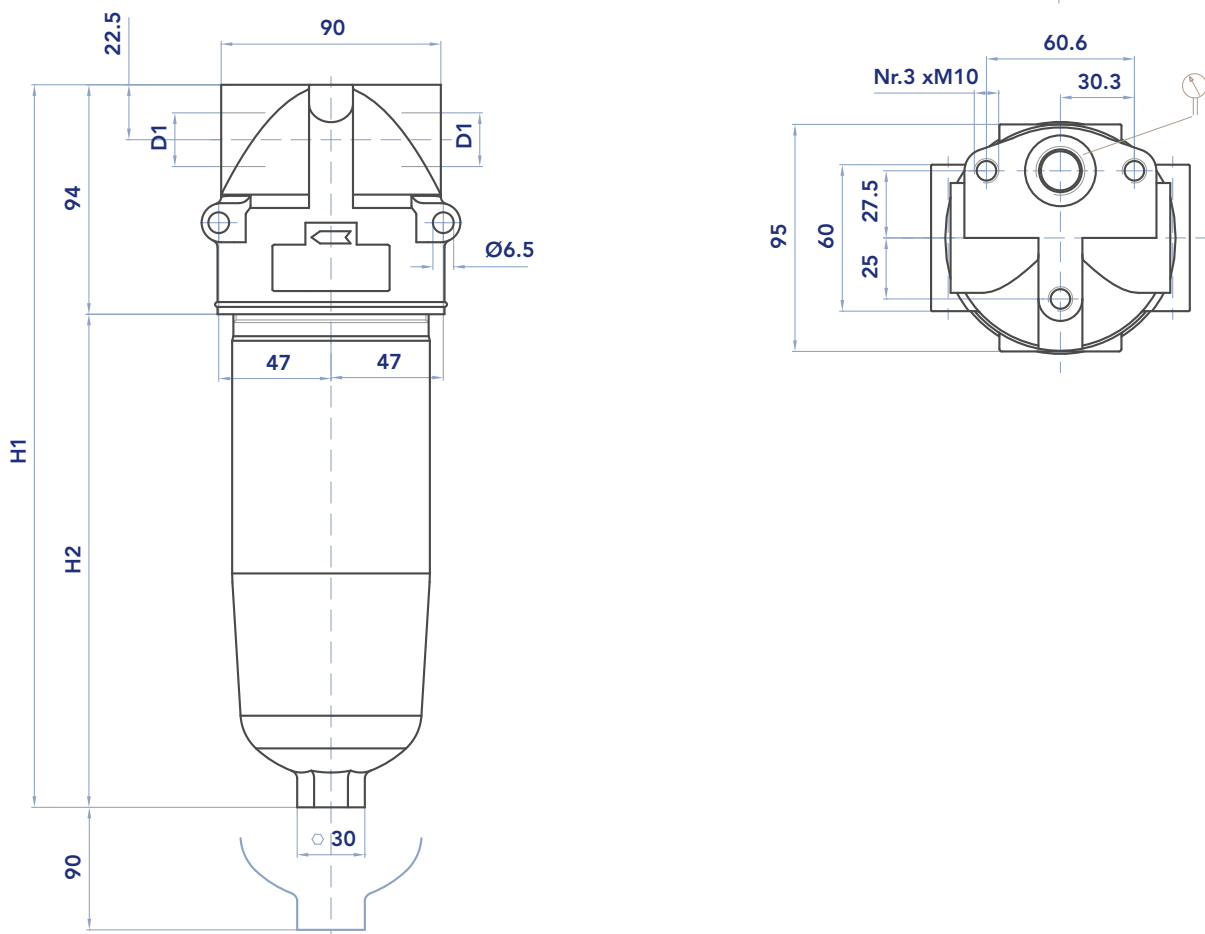

FILTER HOUSING

	D1	H1	H2	R	Kg
FPM21	1/2" - 3/4" - 1"	205	111	100	1,5
FPM22	1/2" - 3/4" - 1"	300	206	100	2,0

FPM

PRESSURE FILTERS



FILTER ELEMENT

	A	B	C	Kg	AREA (cm ²) Media C+
EPB21	52	23,5	115	0,25	780
EPB22	52	23,5	210	0,25	1.465

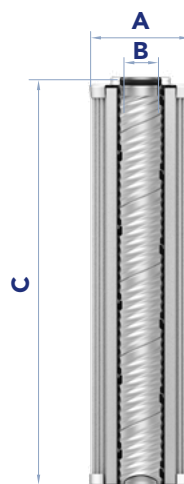

MAINTENANCE

- 1) Stop the system and verify there is no pressure in the filter.
- 2) Collect the oil inside the filter with a suitable container.
- 3) Unscrew the bowl (1) and clean it.
- 4) Remove the dirty filter element (2).
N.B. The exhausted filter elements and the oil dirty filter parts are classified "Dangerous waste material" and must be disposed of according to the local laws, by authorized Companies.
- 5) Check the filter element part number on the filter label or in the ordering and option chart.
Use only original spare parts.
- 6) Lubricate the element o-ring gasket (3) with oil.
- 7) Insert the clean element into its seat with care.
- 8) Check the bowl o-ring condition (4) and lubricate with oil.
If damaged, check the seal kit part number in the spare seal kit table.
N.B. The anti-extrusion o-ring (5) must be positioned with the concave side upwards (gasket side).
- 9) Screw the bowl (1) until it stops, with a tightening torque of 60 Nm + 5/0.

Accessories:

Clogging indicator (6).

If damaged, unscrew and replace it (check the part number in the ordering and option chart).

Lubricate the o-ring gasket with oil and tighten until it stops, with a tightening torque of 40 Nm +5/0.

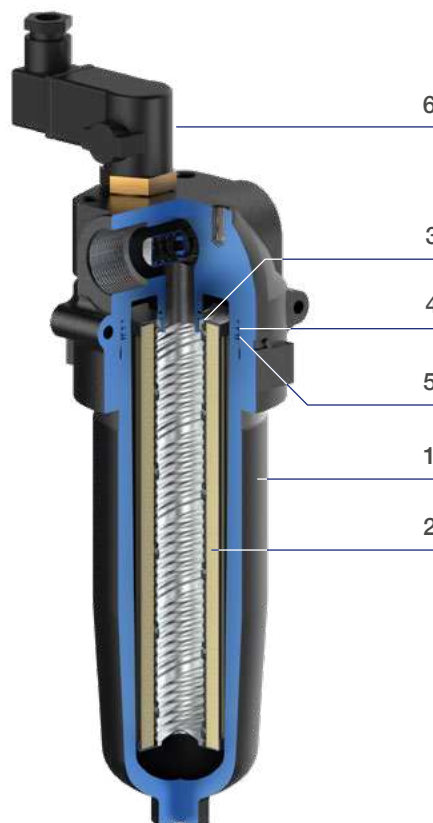



PRESSURE DROP CURVES (Δp)

PRESSURE DROP CURVES (Δp)

The "Assembly Pressure Drop (Δp)" is obtained by adding the pressure drop values of the Filter Housing and of the Clean Filter

Element corresponding to the considered Flow Rate and it must be lower than 120 kPa (1,2 bar). In any case this value should never exceed 1/3 of the bypass setting.

FILTER HOUSING PRESSURE DROP (mainly depending on the port size)

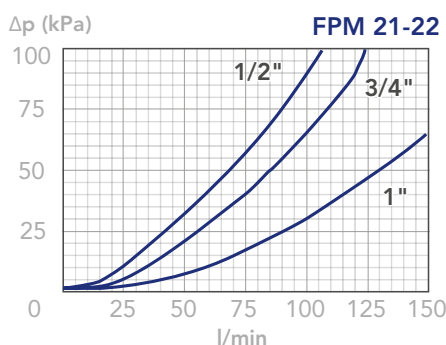

CLEAN FILTER ELEMENT PRESSURE DROP WITH F+ MEDIA

(depending both on the internal diameter of the element and on the filter media)

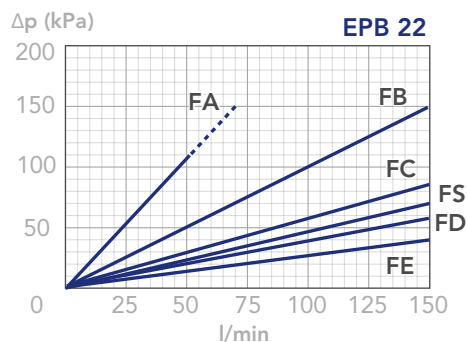
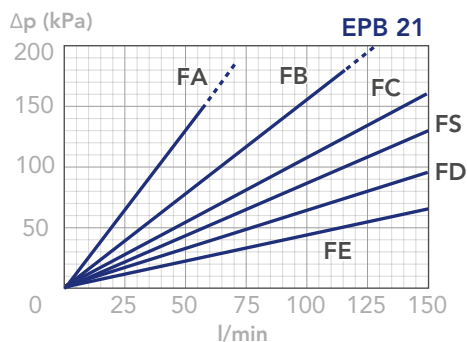

BYPASS VALVE PRESSURE DROP

When selecting the filter size, these curves must be taken into account if it is foreseen that any flow peak is to be absorbed by the bypass valve, it also must be of proper configuration to avoid pressure peaks. The valve pressure drop is directly proportional to fluid specific gravity.

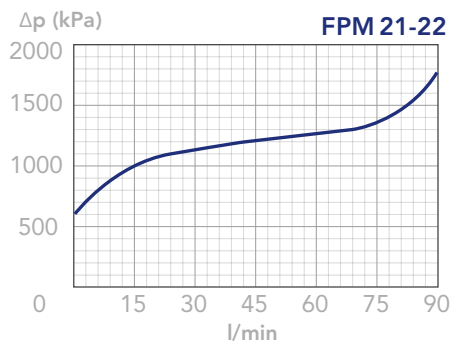

N.B.

All the curves have been obtained with mineral oil having a kinematic viscosity 30 cSt and specific gravity 0,86 kg/dm³; for fluids with different features, please consider the factors described in the first part of this catalogue. All the curves

are obtained from test done at the UFI FILTERS HYDRAULICS Laboratory, according to the specification ISO 3968. In case of discrepancy, please check the contamination level, viscosity and features of the fluid in use.



FPO

PRESSURE FILTERS



DESCRIPTION

High pressure spin-on filter

MATERIALS

Head: Aluminum alloy
Spin-on housing: Steel
Bypass valve: Polyamide
Seals: NBR Nitrile (FKM Fluoroelastomer on request)
Indicator housing: Brass

PRESSURE

Max working: 3,5 MPa (35 bar) for FPO1+
and 2,5 MPa (25 bar) for FPO2+
Collapse, differential for the filter element: 1 MPa (10 bar)

BYPASS VALVE

Setting:
170 kPa (1,7 bar) \pm 10%
350 kPa (3,5 bar) \pm 10%

FLOW RATE

Qmax 250 l/min

WORKING TEMPERATURE

From -25° to +110° C

COMPATIBILITY (ISO 2943)

Full with fluids: HH-HL-HM-HR-HV-HTG (according to ISO 6743/4)
For fluids different than the above mentioned,
please contact our Customer Service.

HYDRAULIC DIAGRAM

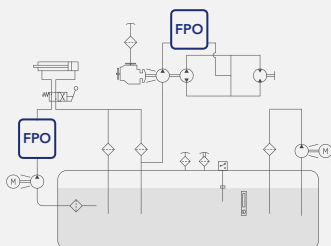

Is this datasheet the latest release? Please check on our website



FPO

PRESSURE FILTERS



ORDERING AND OPTION CHART

F	P	O	COMPLETE FILTER FAMILY						FILTER ELEMENT FAMILY	E	P	O
			SIZE & LENGTH	11	12	14	21	22	SIZE & LENGTH			
			PORT TYPE									
			B = BSP thread	B	B	B	-	-				
			N = NPT thread	N	N	N	-	-				
			PORT SIZE									
			06 = 3/4"	06	06	06	-	-				
			08 = 1"	08	08	08	-	-				
			BYPASS VALVE									
			W = without	W	W	W	-	-				
			B = 170 kPa (1,7 bar)	B	B	B	-	-				
			D = 350 kPa (3,5 bar)	D	D	D	-	-				
			SEALS						SEALS			
			N = NBR Nitrile	N	N	N	-	-				
			FormulaUFI MEDIA						FormulaUFI MEDIA			
			FA = FormulaUFI.MICRON 5 $\mu\text{m}_{(c)}$ $\beta > 1.000$	FA	FA	FA	FA	FA				
			FB = FormulaUFI.MICRON 7 $\mu\text{m}_{(c)}$ $\beta > 1.000$	FB	FB	FB	FB	FB				
			FC = FormulaUFI.MICRON 12 $\mu\text{m}_{(c)}$ $\beta > 1.000$	FC	FC	FC	FC	FC				
			FS = FormulaUFI.MICRON 16 $\mu\text{m}_{(c)}$ $\beta > 1.000$	FS	FS	FS	FS	FS				
			FD = FormulaUFI.MICRON 21 $\mu\text{m}_{(c)}$ $\beta > 1.000$	FD	FD	FD	FD	FD				
			CLOGGING INDICATOR									
			03 = port, plugged	03	03	03	-	-				
			5B = visual differential 130 kPa (1,3 bar)	5B	5B	5B	-	-				
			6B = electrical differential 130 kPa (1,3 bar)	6B	6B	6B	-	-				
			7B = indicator 6B with LED	7B	7B	7B	-	-				
			T0 = elect. diff. 130 kPa (1,3 bar) with thermostat 30°	T0	T0	T0	-	-				
			5D = visual differential 250 kPa (2,5 bar)	5D	5D	5D	-	-				
			6D = electrical differential 250 kPa (2,5 bar)	6D	6D	6D	-	-				
			7D = indicator 6D with LED	7D	7D	7D	-	-				
			T6 = elect. diff. 250 kPa (2,5 bar) with thermostat 30°	T6	T6	T6	-	-				
X	X		ACCESSORI / ACCESSORIES									
			XX = no accessory available	XX	XX	XX	-	-				

SPARE PARTS

FILTER HOUSING				FILTER ELEMENT				CLOGGING INDICATOR			
											
B	P	O		E	P	O					

INSTALLATION DRAWING

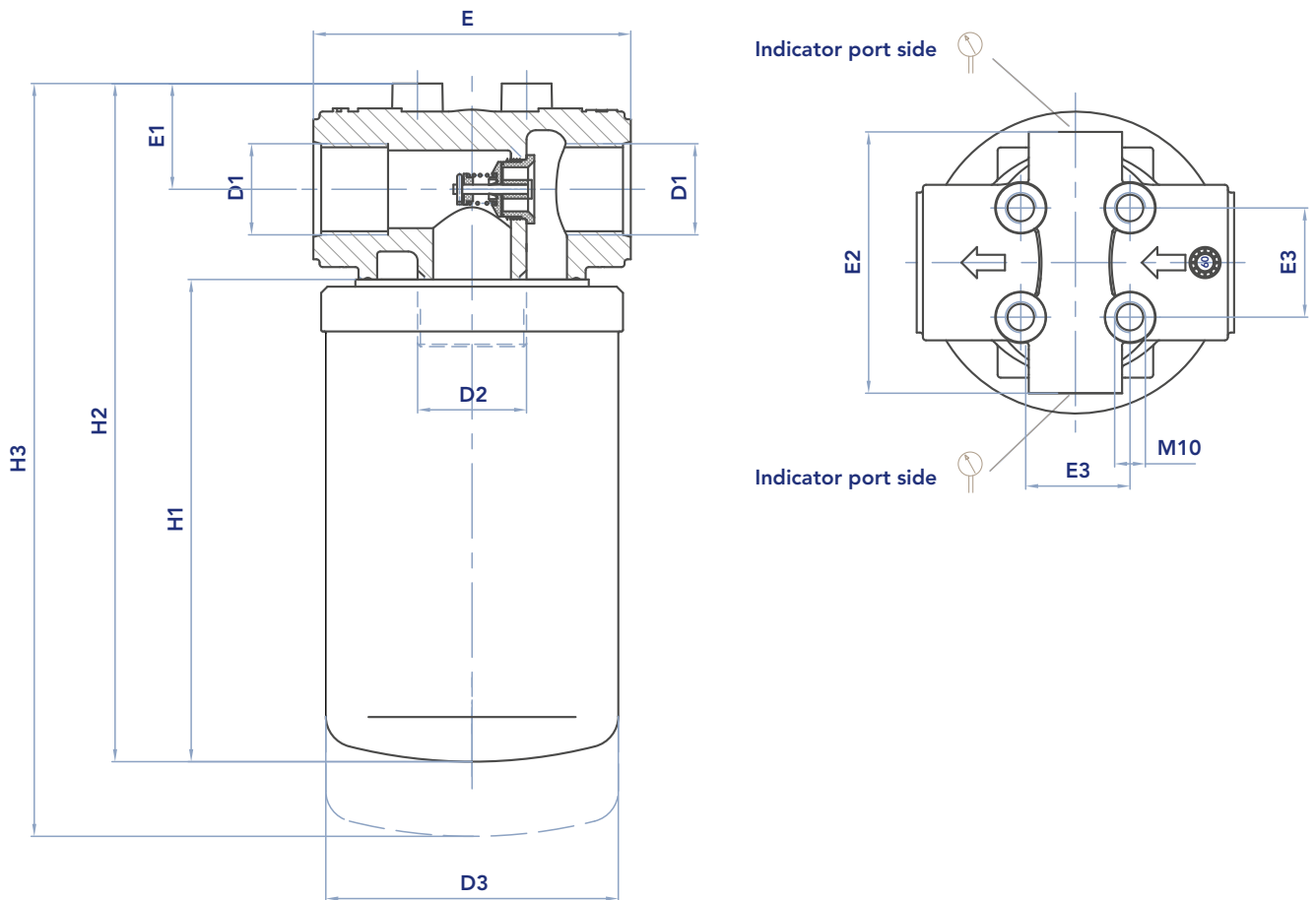

FILTER HOUSING

	D1	D2	D3	E	E1	E2	E3	H1	H2	H3	Kg
FPO11	3/4"-1"	1"3/8-12 UNF 2A	94	102	36	84	35	155	219	243	1,6
FPO12	3/4"-1"	1"3/8-12 UNF 2A	94	102	36	84	35	182	246	270	1,7
FPO13	3/4"-1"	1"3/8-12 UNF 2A	94	102	36	84	35	228	292	316	1,9
FPO14	3/4"-1"	1"3/8-12 UNF 2A	94	102	36	84	35	240	304	328	2,0

FPO

PRESSURE FILTERS



FILTER ELEMENT

	A	B	C	Kg	AREA (cm ²) Media F+
EPO11	97	1 3/8"-12 UNF 2B	155	0,9	1.860
EPO12	97	1 3/8"-12 UNF 2B	182	1,0	2.285
EPO13	97	1 3/8"-12 UNF 2B	228	1,2	3.110
EPO14	97	1 3/8"-12 UNF 2B	240	1,3	3.320
EPO21	121	1 3/4"-12 UN 2B	294	2,3	5.060
EPO22	121	1 3/4"-12 UN 2B	361	2,7	6.300

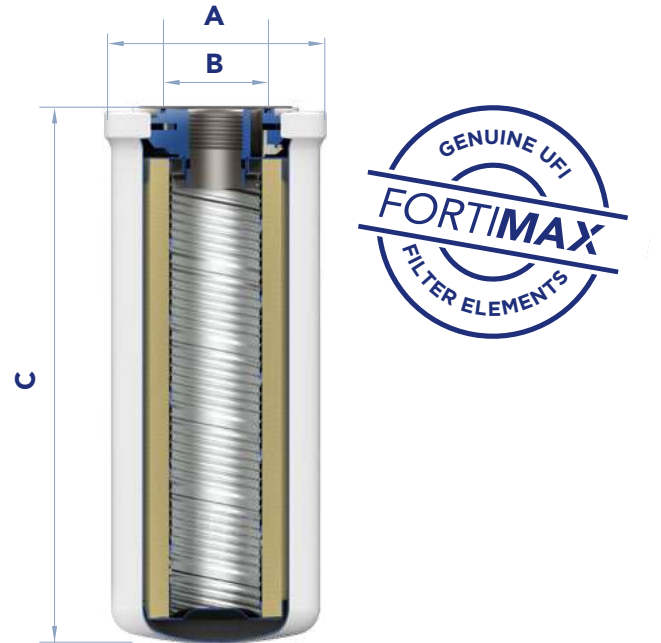

The FORTIMAX series includes also several additional dimensions and options. Please check our website for the dedicated brochure or contact our Sales Team or Customer Service for further information and support.

MAINTENANCE

- 1) Stop the system and verify there is no pressure in the filter.
- 2) Collect the oil inside the filter with a suitable container.
- 3) Unscrew the dirty filter element (1).
N.B. The exhausted filter elements and the oil dirty filter parts are classified "Dangerous waste material" and must be disposed of according to the local laws, by authorized Companies.
- 4) Check the filter element part number on the silk-screen printing or in the ordering and option chart.
Use only original spare parts.
- 5) Lubricate the element o-ring gasket with oil.
- 6) Screw the clean filter element until the first contact of the gasket with the flange.
- 7) Tighten strongly for ¾ of a turn (indicative tightening torque of 18 Nm).

Accessories:

Clogging indicator

If damaged, unscrew and replace it (check the part number in the ordering and option chart).

Apply a thread-sealing and screw until tight. N.B. An over-tightening can damage the thread.





PRESSURE DROP CURVES (Δp)

The “Assembly Pressure Drop (Δp)” is obtained by adding the pressure drop values of the Filter Housing and of the Clean Filter Element corresponding to the considered Flow Rate and it must be

lower than 120 kPa (1,2 bar). In any case this value should never exceed 1/3 of the bypass setting.

FILTER HOUSING PRESSURE DROP
(mainly depending on the port size)

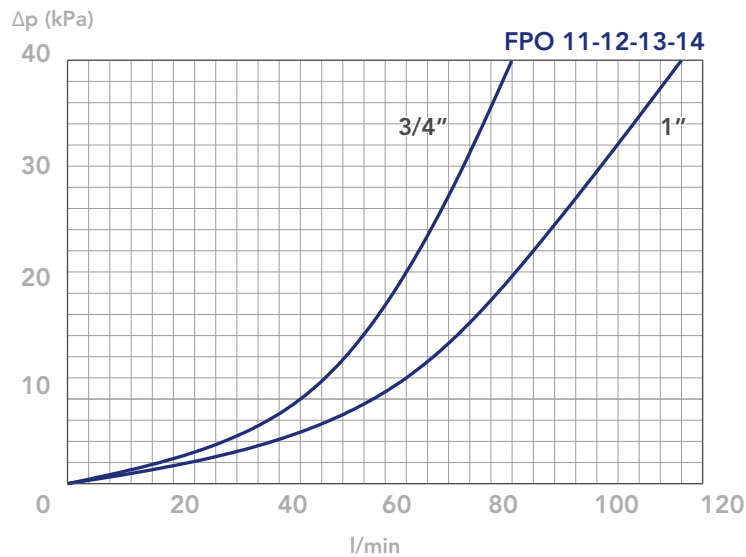

BYPASS VALVE PRESSURE DROP

When selecting the filter size, these curves must be taken into account if it is foreseen that any flow peak is to be absorbed by the bypass valve, it also must be of proper configuration to avoid pressure peaks. The valve pressure drop is directly proportional to fluid specific gravity.

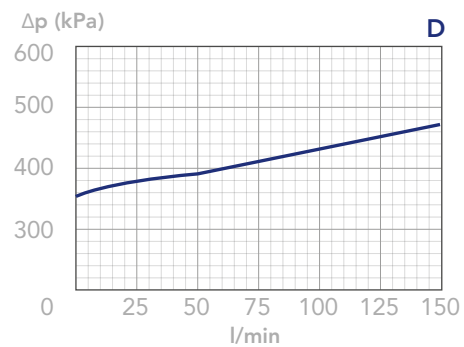
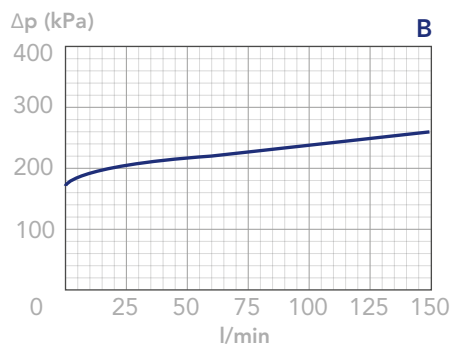

FPO

PRESSURE FILTERS

CLEAN FILTER ELEMENT PRESSURE DROP WITH F+ MEDIA
(depending both on the internal diameter of the element and on the filter media)

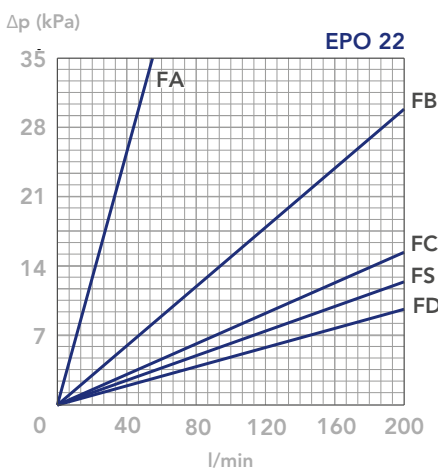
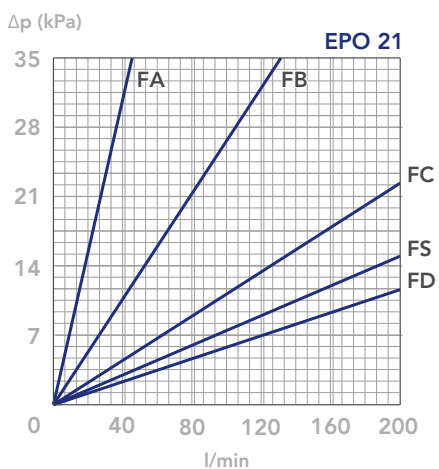
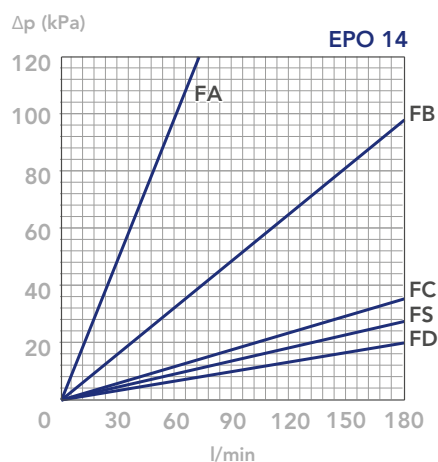
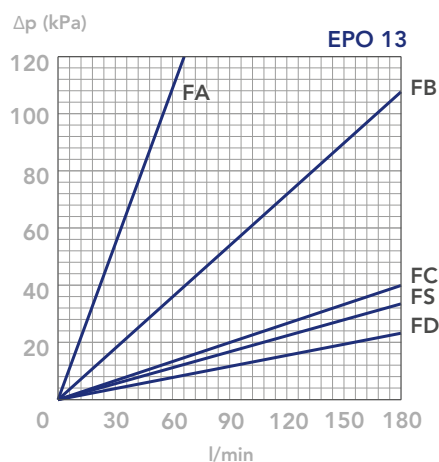
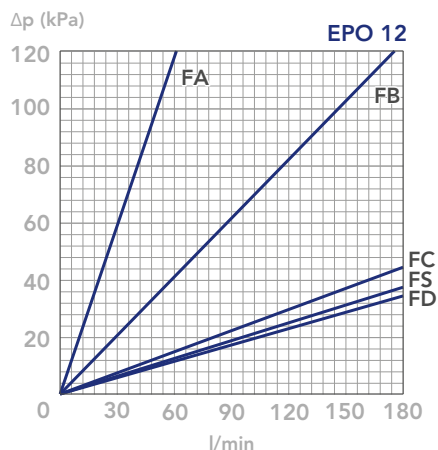
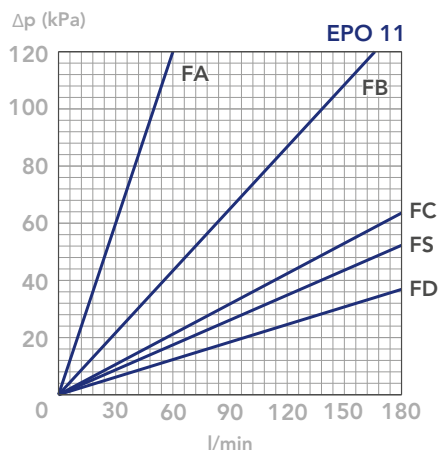

N.B.

All the curves have been obtained with mineral oil having a kinematic viscosity 30 cSt and specific gravity 0,86 Kg/dm³; for fluids with different features, please consider the factors described in the first part of this catalogue. All the curves

are obtained from test done at the UFI FILTERS HYDRAULICS Laboratory, according to the specification ISO 3968. In case of discrepancy, please check the contamination level, viscosity and features of the fluid in use.

LubeTeam Hydraulic S.r.l.

Administration and Headquarter:

Via Tufara Scautieri, 6

83018 - San Martino Valle Caudina (AV)

Office and Warehouse:

S.S. 7 Appia, Km. 237,00

82011 - Airola BN

ITALY

Tel. +39 0823 950 994

Fax +39 0823 412 546

www.lubeteam.it info@lubeteam.it

Italian VAT / C.F. e P.IVA: 01251720627

Follow us



This document is the property of LubeTeam Hydraulic S.r.l. All data reported here are for the exclusive use of the Receiver. Reproduction is not authorized without writing permission, in all or in part of the content of this document, in accordance to Law 633 art. 171, dated April 22, 1941.

Il presente documento è di proprietà della LubeTeam Hydraulic S.r.l. I dati riportati sono per esclusivo del destinatario. La riproduzione, di tutto o in parte, non è autorizzata senza permesso scritto secondo l'art. 171 della L. 633 del 22 Aprile 1941.