



OLEODINAMICA BORELLI  
Organi di trasmissione  
Innesti Elettromagnetici



 HYDRAULIC  
COMPONENTS  
& FLUID CONTAMINATION  
CONTROL



All trademarks belong to their respective owners; third party trademarks, product names, trade names, corporate names and company names mentioned may be trademarks of their respective owners or registered trademarks of other companies and are used for instructional purposes and for the benefit of the owner, without any end of Copyright infringement in force.

Tutti i marchi riportati appartengono ai legittimi proprietari; marchi di terzi, nomi di prodotti, nomi commerciali, nomi corporativi e società citati possono essere di proprietà dei rispettivi titolari o registrati da altre società e sono stati utilizzati a puro scopo esplicativo e a beneficio del possessore, senza alcun fine di violazione dei diritti di Copyright vigenti.



OLEODINAMICA **BORELLI**  
HYDRAULIC COMPONENTS

catalogo  
INNESTI  
ELETTROMAGNETICI







- INNESTI ELETTROMAGNETICI
- EMBRAYAGES ÉLECTROMAGNÉTIQUES
  - ELECTROMAGNETIC COUPLINGS
- ELEKTROMAGNETISCHE KUPPLUNGEN

### **INNESTI ELETTROMAGNETICI SERIE 30900**

Per ottenere i valori richiesti di coppia nominale degli INNESTI ELETTROMAGNETICI bisogna sottoporli ad una fase di rodaggio. Il completamento del rodaggio si riferisce a più operazioni di "Innesto" e "Disinnesto" della frizione ad elevata velocità con la pompa in scarico. Importante controllare nella fase di montaggio che sulle superfici di trascinamento della puleggia non vi siano presenti tracce di olio, o grasso o altre sostanze untuose, ma devono essere perfettamente pulite.

Il montaggio di elettrofrizioni, con frangia per trascinamento frontale su unità, occorre controllare l'esatto allineamento dell'accoppiamento. L'applicazione delle frizioni elettromagnetiche non deve superare la coppia nominale perché si determinerebbe uno slittamento delle superfici di contatto; questa fase non deve durare oltre 5 secondi, perché le bobine potrebbero bruciare.

### **EMBAYAGES ÉLECTROMAGNÉTIQUES SERIE 30900**

Pour obtenir les valeurs requises de couple nominal des embrayages électromagnétiques, il faut les soumettre à une phase de rodage. Le rodage se compose de plusieurs opérations d'embrayages et de débrayage à vitesse élevée avec la pompe en décharge. Au cours de la phase de montage, il est important de contrôler qu'il n'y ait pas de traces d'huile ni de graisse ni d'autres substances grasses sur les surfaces d'entraînement de la poulie; elles doivent être parfaitement propres.

Pour le montage d'électro-embrayages avec bride pour entraînement frontal sur des unités, il faut vérifier que l'alignement de l'accouplement soit parfait. L'application des embrayages électromagnétiques ne doit pas dépasser le couple nominal car cela entraînerait un patinement des surfaces de contact; cette phase ne doit pas durer plus de 5 secondes car les bobines pourraient se brûler.

### **ELECTROMAGNETIC COUPLINGS SERIES 30900**

Running-in is required to obtain the desired rated torque values of electromagnetic couplings. Running-in is carried out by engaging and disengaging clutch at high speed several times with the pump in exhaust position.

During assembly, make sure that there are no oil or grease traces on pulley surfaces which must be completely clean.

When assembling electric clutches with front driving flange, check for proper coupling alignment, but do not exceed rated torque because this would cause slippage of contact surface. This stage must not last more than 5 secs since coils could burn.

### **MAGNETKUPPLUNGEN SERIE 30900**

Um mit den Magnetkupplungen auf die gewünschten Nenndrehmomente zu kommen, müssen die Magnetkupplungen einer Einlaufphase unterzogen werden. Das Einlaufen der Magnetkupplung erfolgt durch mehrmalige Ein-/Auskupplungen bei ausgekuppelter Kupplung und unbelasteter Pumpe. Bei der Montage ist es äusserst wichtig sicherzustellen, daß in der Mitnehmerille der Riemenscheibe keine Öltropfen, Körner oder andere ölige Substanzen vorhanden sind. Die Riemenscheibe muß einwandfrei sauber sein.

Bei der Montage von Magnetkupplungen mit Flansch für stirnseitige Montage, muß sichergestellt werden, daß das Aggregat genaustens in der Achse gefluchtet ist.

Beim Einsatz der Magnetkupplungen muß ausserdem gewährleistet sein, daß das vorgeschriebene Nenndrehmoment nicht überschritten wird, da ansonsten die Kontaktflächen zu lange schleifen; diese Phase darf nicht über 5 s dauern, da ansonsten die Wicklungen durchbrennen.

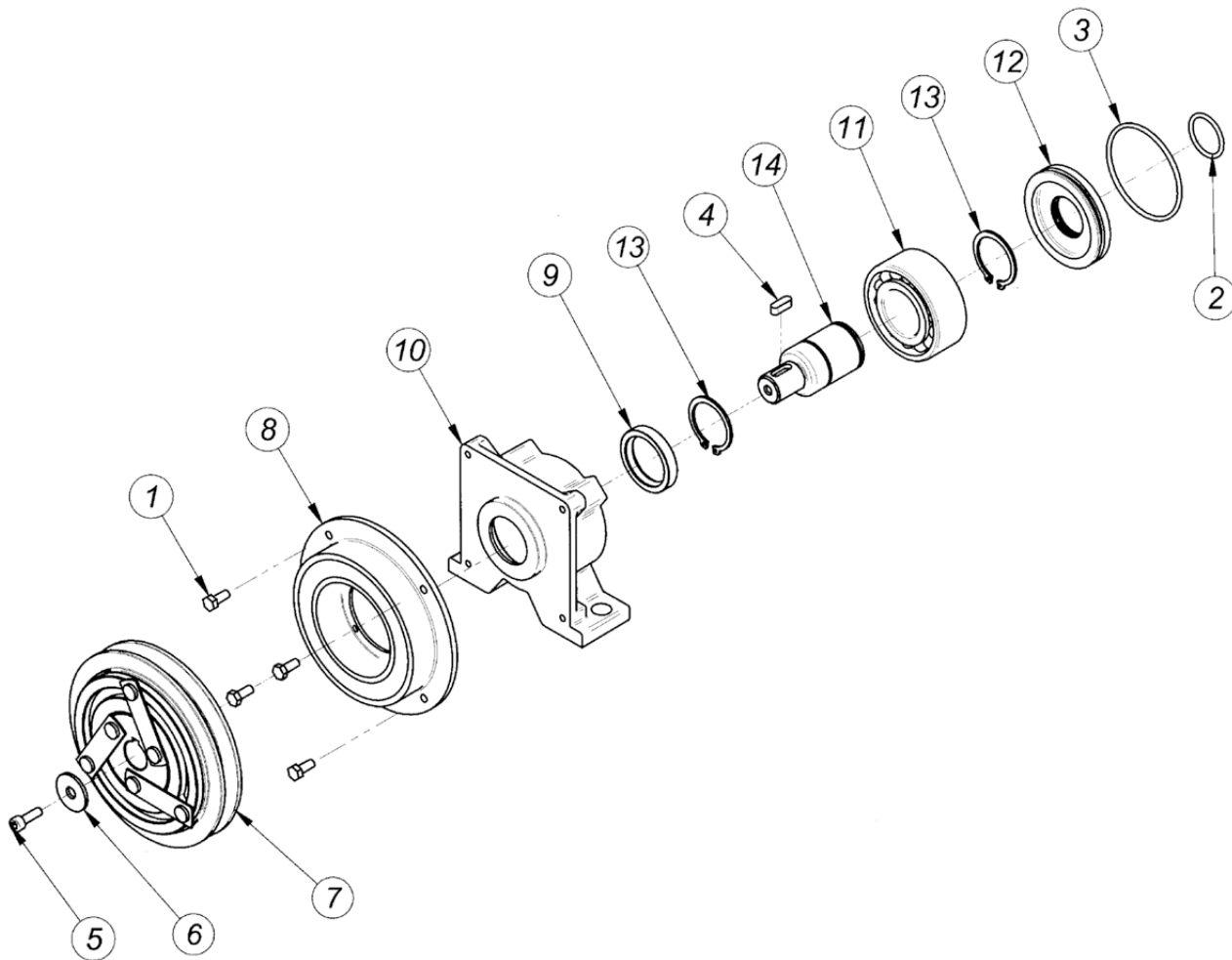

Pos.	CODICE	DENOMINAZIONE	DENOMINATION	DESCRIPTION	BEZEICHNUNG	Q.TA'
1	620512	Vite EN 24017 M5x12	Vis EN 24017 M5x12	Socket EN 24017 M5x12	Befestigungsschraube EN 24017 M5x12	4
2	402100	Anello OR	Bague torique	O-Ring	O-Ring	1
3	403225	Anello OR D.60	Bague torique d.60	O-Ring d.60	O-Ring d.60	1
4	435515	Linguetta UNI 6604 A 5x5x20	Languettes UNI 6604 5x5x20	Woudruff key UNI 6604 5x5x20	Halbrundkeil UNI 6604 5x5x20	1
5	610620	VTCEI UNI 5931 M6x12	Vis TCHC UNI 5931 M6x12	Socket capscrew UNI 5931 M6x12	Befestigungsschraube UNI 5931 M6x12	1
6	RSP246	Rosetta UNI 6593 - 6x24x2	Rondelle UNI 6593 - 6x24x2	Washer UNI 6593 - 6x24x2	Rosette UNI 6593 - 6x24x2	1
7	4003/125BP	Puleggia elettrofrizione	Poulie embrayage électrique	Electric clutch pulley	Elektroschaltkupplungsscheibe	1
8	401203-125B 402403/125B	Bobina	Bobine	Coil	Zundspüle	1
9	303040	Anello di tenuta 30x40x7	Bague d'étanchéité 30x40x7	Sealing ring 30x40x7	Dichtring 30x40x7	1
10	30009/3	Scatola	Carcasse	Housing	Gehäuse	1
11	503206	Cuscinetto SKF 3206	Palier SKF 3206	Bearing SKF 3206	Kugellager SKF 3206	1
12	COP-062	Anello	Bague	Ring	Ring	1
13	903000	Anello elastico UNI 7436 - 25	Circlip UNI 7436 - 25	Snap ring UNI 7436 - 25	Seegerring UNI 7436 - 25	2
14	AC30900	Albero	Arbre	Shaft	Welle	1



- **INNESTO ELETTROMAGNETICO 3 daNm**
- **EMBAYAGE ELECTROMAGNETIQUE 3 daNm**
- **ELECTROMAGNETIC COUPLING 3 daNm**
- **ELEKTROMAGNETISCHE SCHALTKUPPLUNGEN 3 daNm**

**SERIE: 30900-1 12 Volt**  
**SERIE: 30900-2 24 Volt**

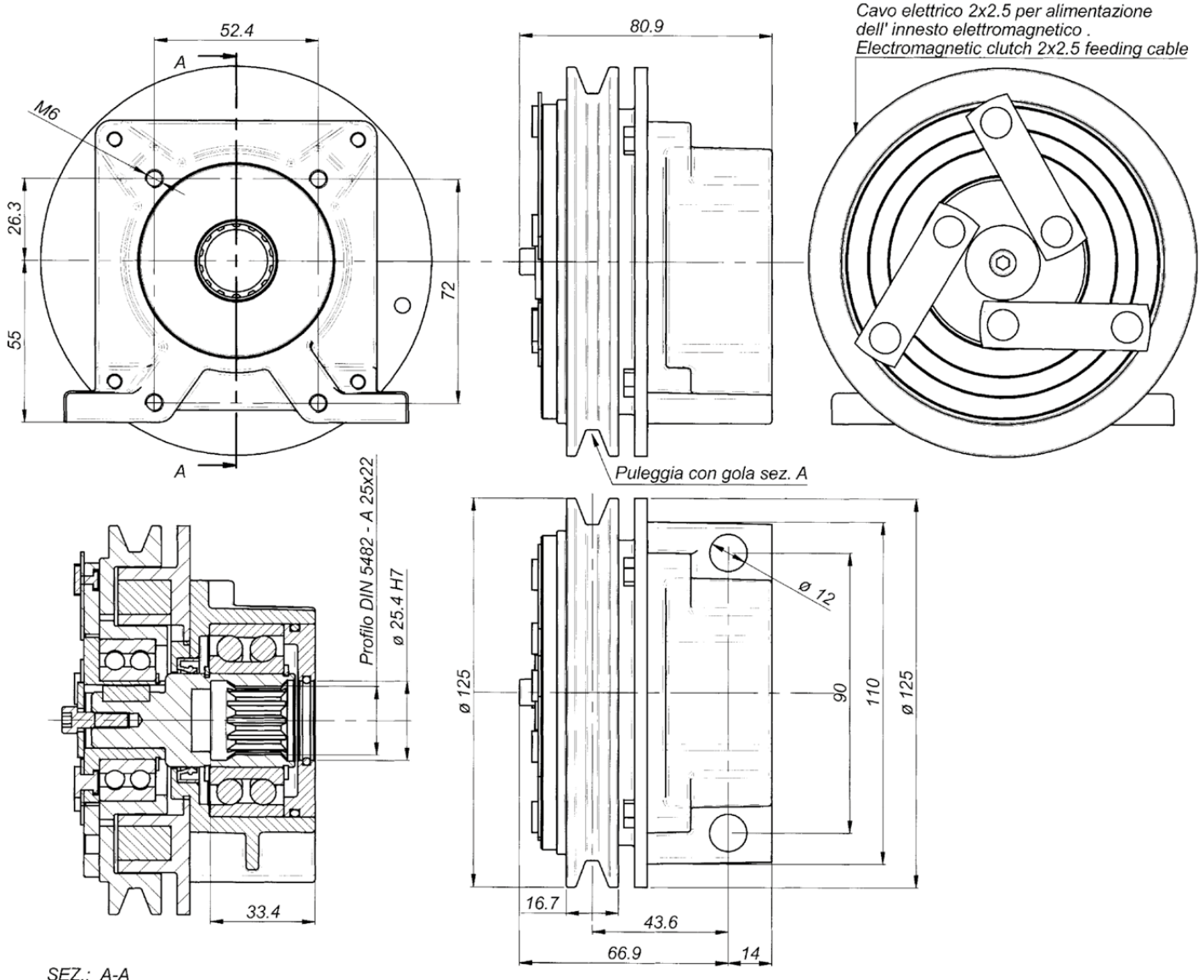

Cavo elettrico 2x2.5 per alimentazione dell' innesto elettromagnetico .  
Electromagnetic clutch 2x2.5 feeding cable

SEZ.: A-A

Nominal torque	3,0 daNm		Connection time	25 m/sec		
Static torque	4,5 daNm		Disconnection time	40 m/sec		
Dynamic torque	3,2 daNm	at 500 rpm	Minimun time between two connection	20 sec		
	2,8 daNm	at 1000 rpm				
	1,7 daNm	at 1500 rpm				
	1,4 daNm	at 2000 rpm	Max speed	5000 rpm		
	1,2 daNm	at 2500 rpm	Weight	3 Kg		
	0,9 daNm	at 3000 rpm				
Electric absorption	Resistance ( W )		Current ( A )		Power ( W )	
	20° C	120° C	20° C	120° C	20° C	120° C
12 V DC	5,7	7,9	2,1	1,6	25,2	18
24 V DC	21,7	30,7	1,1	0,8	26,5	19
All technical data are at 20°C / at 120° C the performance are less 20% All electromageteic clutches are reversible.						

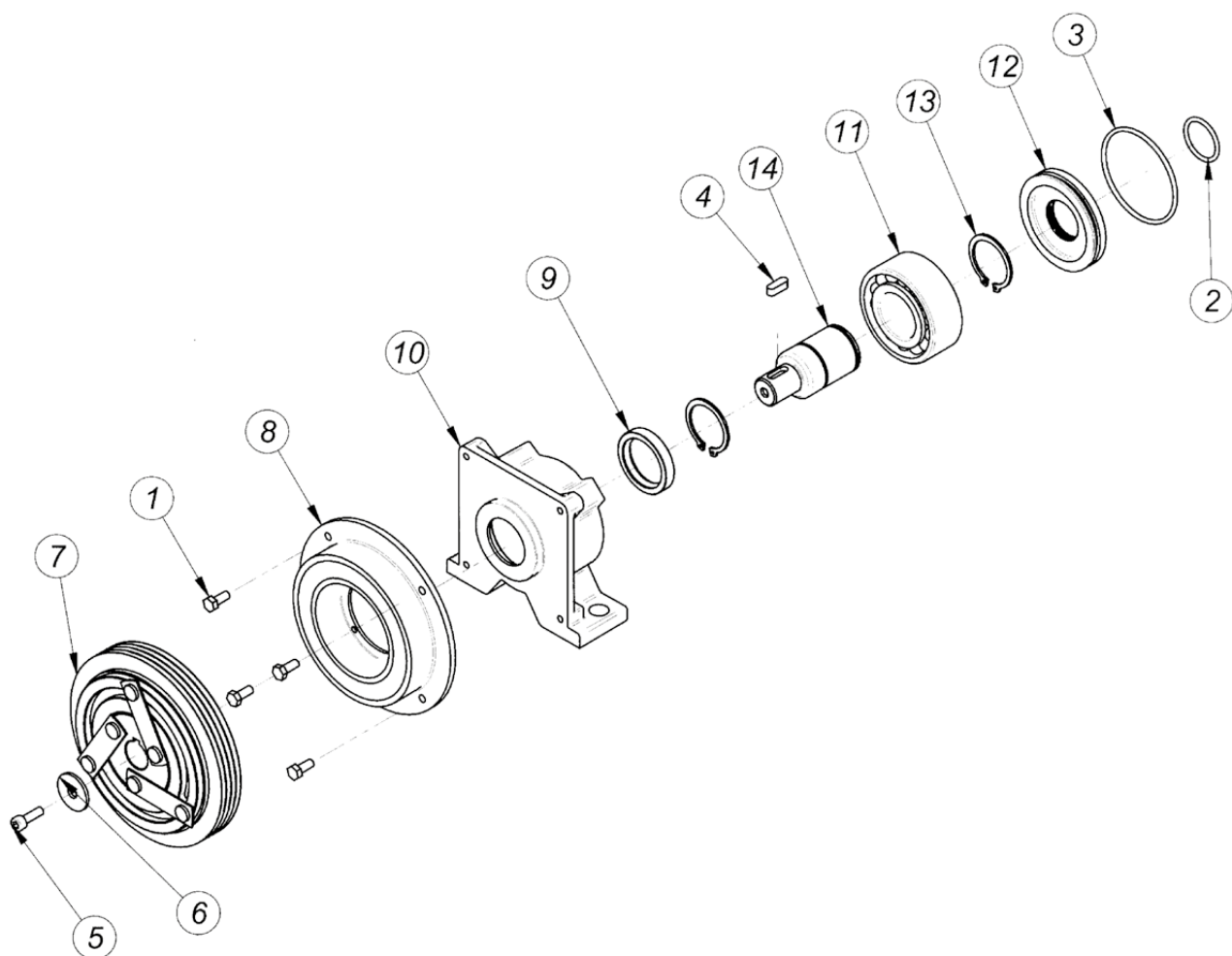

Pos.	CODICE	DENOMINAZIONE	DENOMINATION	DESCRIPTION	BEZEICHNUNG	Q.TA'
1	620512	Vite EN 24017 M5x12	Vis EN 24017 M5x12	Socket EN 24017 M5x12	Befestigungsschraube EN 24017 M5x12	4
2	402100	Anello OR	Bague torique	O-Ring	O-Ring	1
3	403225	Anello OR D.60	Bague torique d.60	O-Ring d.60	O-Ring d.60	1
4	435515	Linguetta UNI 6604 A 5x5x20	Languette UNI 6604 5x5x20	Woudruff key UNI 6604 5x5x20	Halbrundkeil UNI 6604 5x5x20	1
5	610620	VTCEI UNI 5931 M6x12	Vis TCHC UNI 5931 M6x12	Socket capscrew UNI 5931 M6x12	Befestigungsschraube UNI 5931 M6x12	1
6	RSP246	Rosetta UNI 6593 - 6x24x2	Rondelle UNI 6593 - 6x24x2	Washer UNI 6593 - 6x24x2	Rosette UNI 6593 - 6x24x2	1
7	4003/125PLVP	PULEGGIA CINGHIE POLI "V" ELETTROFRIZIONE	POULIE "V" Electro-embayage	PULLEY "V" Electric clutch	RIEMENSCHIEBE "V" Elektroschaltkupplung	1
8	401203/125B 402403/125B	Bobina	Bobine	Coil	Zundspule	1
9	303040	Anello di tenuta 30x40x7	Bague d'etancheite 30x40x7	Sealing ring 30x40x7	Dichtring 30x40x7	1
10	30009/3	Scatola	Carcasse	Housing	Gehause	1
11	503206	Cuscinetto SKF 3206	Palier SKF 3206	Bearing SKF 3206	Kugellager SKF 3206	1
12	COP-062	Anello	Bague	Ring	Ring	1
13	903000	Anello elastico UNI 7436 - 25	Circlip UNI 7436 - 25	Snap ring UNI 7436 - 25	Seegerring UNI 7436 - 25	2
14	AC30900	Albero	Arbre	Shaft	Welle	1





- **INNESTO ELETTROMAGNETICO 3 daNm**
- **EMBAYAGE ELECTROMAGNETIQUE 3 daNm**
- **ELECTROMAGNETIC COUPLING 3 daNm**
- **ELEKTROMAGNETISCHE SCHALKUPPLUNGEN 3 daNm**

**SERIE: 30900-1/N1 12 Volt**  
**SERIE: 30900-2/N1 24 Volt**

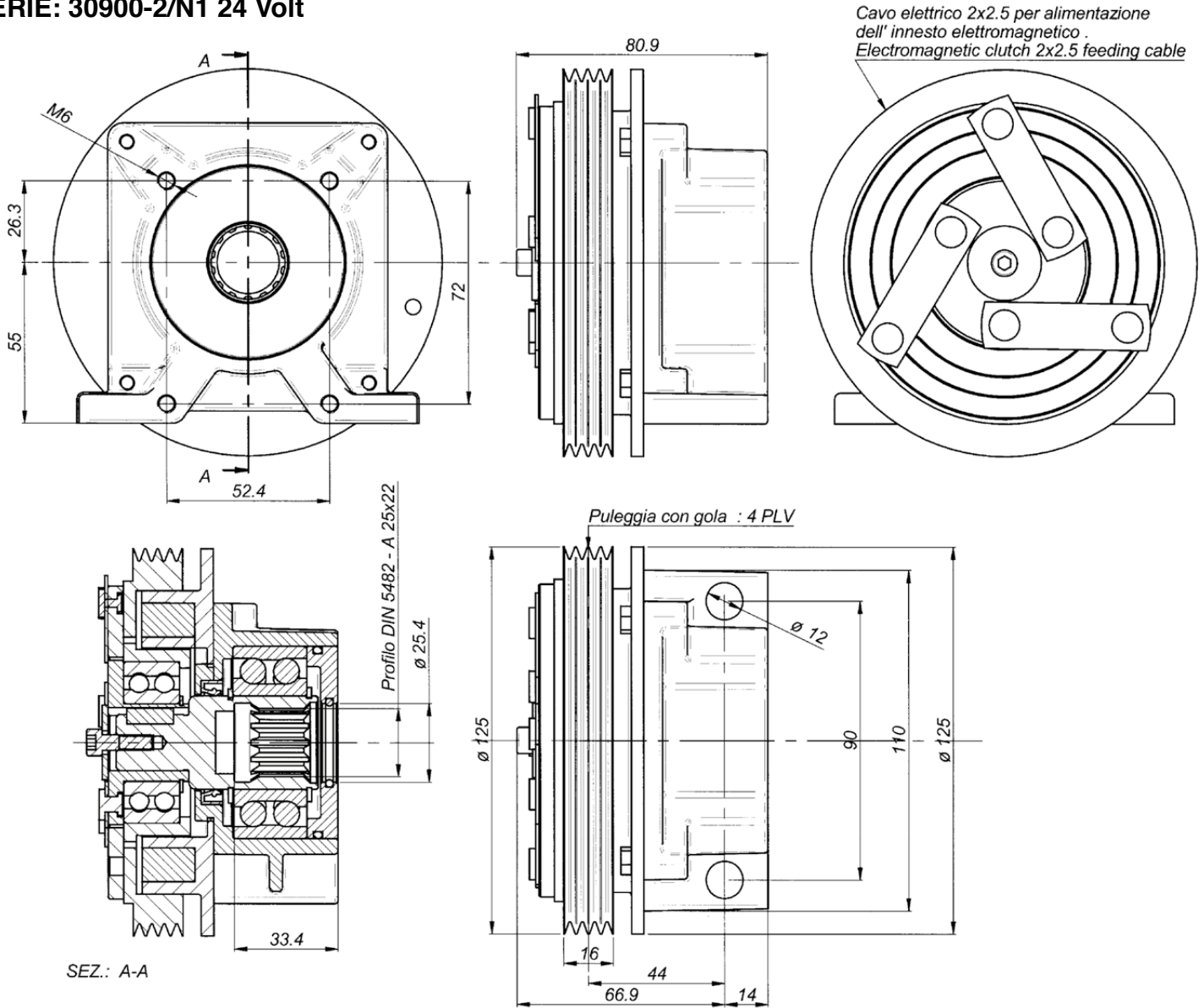

Nominal torque	3,0 daNm		Connection time	25 m/sec		
Static torque	4,5 daNm		Disconnection time	40 m/sec		
Dynamic torque	3,2 daNm	at 500 rpm	Minimum time between two connection	20 sec		
	2,8 daNm	at 1000 rpm				
	1,7 daNm	at 1500 rpm				
	1,4 daNm	at 2000 rpm	Max speed	5000 rpm		
	1,2 daNm	at 2500 rpm	Weight	3 Kg		
	0,9 daNm	at 3000 rpm				
Electric absorption	Resistance ( W )		Current ( A )		Power ( W )	
	20° C	120° C	20° C	120° C	20° C	120° C
12 V DC	5,7	7,9	2,1	1,6	25,2	18
24 V DC	21,7	30,7	1,1	0,8	26,5	19

All technical data are at 20°C / at 120° C the performance are less 20%  
All electromagneteic clutches are reversible.



- TAVOLA RICAMBI INNESTO ELETTROMAGNETICO TIPO FRONTALE 10daNm
- TABLEAU DES PIECES DETACHEES POUR EMBRAYAGE ELECTROMAGNETIQUE FRONTAL TYPE 10 daNm
- SPARE PARTS TABLE FOR ELECTROMAGNETIC COUPLING FRONTAL 10 daNm
- ERSATZTEILLISTE FUR ELEKTROMAGNETISCHE SCHALT Kupplungen 3daNm

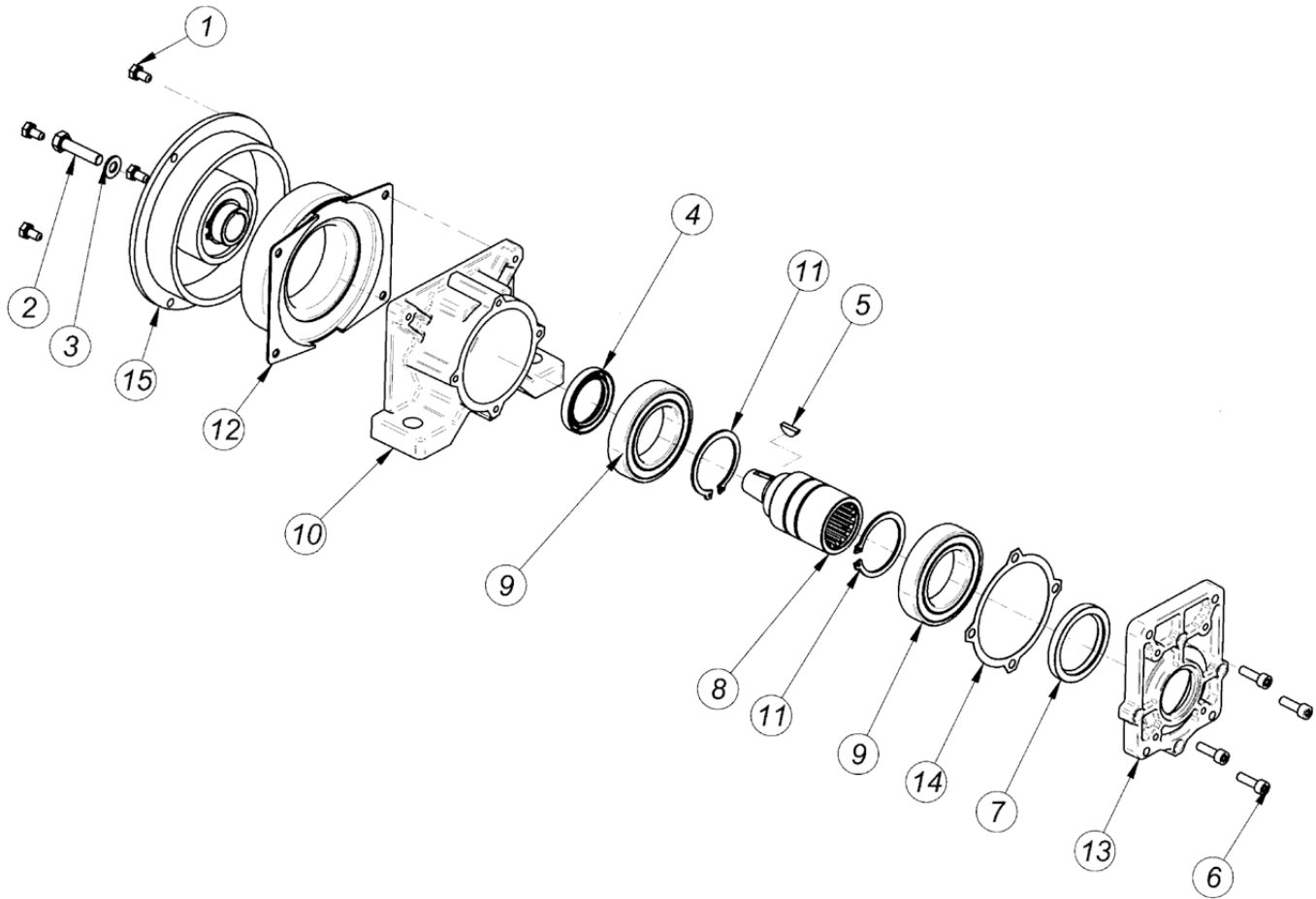

Pos.	CODICE	DENOMINAZIONE	DENOMINATION	DESCRIPTION	BEZEICHNUNG	Q.TA'
1	611428	Vite EN 24017 M6x12	Vis EN24017 M6x12	Soket EN 24017 M6x12	Befestigungsschraube EN 24017 M6x12	4
2	610516	Vite EN 24017 M8x35	Vis EN 24017 M8x35	Socket EN 24017 M8x35	Befestigungsschraube EN 24017 M8x35	1
3	RSPAL8	Rosetta per M8	Rondelle D.8	Washer d.8	Rosette durchm 8	1
4	303550	Anello di tenuta 35x50x7	Bague d'etancheite 35x50x7	Sealing ring 35x50x7	Dichtring 35x50x7	1
5	700465	Linguetta UNI 6606 4x6.5	Langnette UNI 6606 4x6.5	Woodruff key UNI 6606 4x6.5	Halbrundkeil UNI 6606 4x6.5	1
6	610620	Vite T.C.E.I M6x20	Vis T.C.H.C. M6x20	Socket capscREW M6x20	Befestigungsschraube UNI 5931 M6x20	4
7	304560	Anello di tenuta 45x60x7	Bague d'etancheite 45x60x7	Sealing ring 45x60x7	Dichtring 45x60x7	1
8	A30901	Albero	Arbre	Shaft	Welle	1
9	506009/2Z	Cuscinetto 6009 2rs	Palier SKF 6009 2RS	Bearing SKF 6009 2RS	Kugellager SKF 6009-2RS	2
10	30009.1	Scatola	Carcasse	Housing	Gehäuse	1
11	904500	Anello elastico d.45	Circlip d.45	Snap ring d.45	Seegerring d.45	2
12	401210/FRB 402410/FRB	Bobina	Bobine	Coil	Zundspüle	1
13	30900.1	Flangia per pompe Gr 1 - 2	Flasque puor pompes Gr 1 - 2	Flange for pumps Gr 1 - 2	Flansch fur pumpe Gr 1- 2	1
14	30009.1.1	Guarnizione	Joint	Gasket	Dichtung	1
15	4010/FRBP	Elettrofrizione frontale	Electro-embayage frontal	Electric clutch	Elektroschaltkupplung strirnbauweise	1



- **INNESTO ELETTROMAGNETICO TIPO FRONTALE 10 daNm**
- **EMBRAYAGE ELECTROMAGNETIQUE FRONTAL TYPE 10 daNm**
- **ELECTROMAGNETIC COUPLING FRONTAL TYPE 10 daNm**
- **ELEKTROMAGNETISCHE SCHALKUPPLUNGEN 10 daNm**

SERIE: 30933 12 Volt  
SERIE: 30934 24 Volt

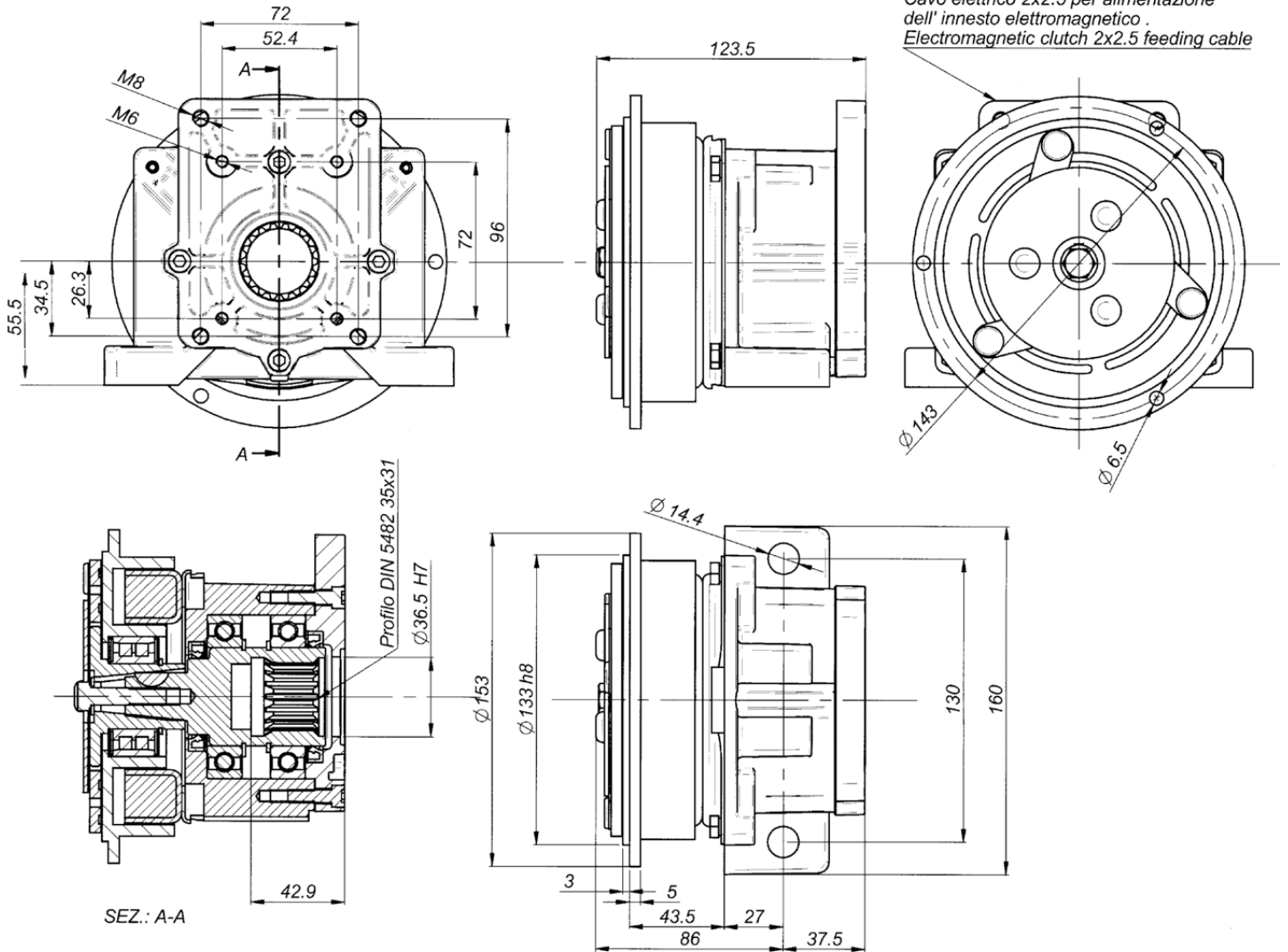

Nominal torque	7,8 daNm		Connection time	25 m/sec		
Static torque	12,5 daNm		Disconnection time	40 m/sec		
Dynamic torque	8,5 daNm	at 500 rpm	Minimum time between two connection	20 sec		
	7,0 daNm	at 1000 rpm				
	4,2 daNm	at 1500 rpm				
	3,5 daNm	at 2000 rpm	Max speed	5000 rpm		
	2,7 daNm	at 2500 rpm	Weight	5 Kg		
	2,5 daNm	at 3000 rpm				
Electric absorption	Resistance ( $\Omega$ )		Current ( A )		Power ( W )	
	20° C	120° C	20° C	120° C	20° C	120° C
12 V DC	4,00	5,60	3,33	2,00	40,00	24,00
24 V DC	20,00	28,00	1,26	0,77	30,30	18,18
All technical data are at 20°C / at 120 °C the performance are less 20% All electromagneteic clutches are reversible.						



- FLANGE PER INNESTI ELETTROMAGNETICI 10 daNm
- BRIDE POUR EMBRAYAGES ELECTROMAGNETIQUE 10 daNm
- FLANGES FOR ELECTROMAGNETIC COUPLING 10 daNm
- FLANSCHEN FÜR ELEKTROMAGNETISCHE SCHALTKUPPLUNGEN 10 daNm

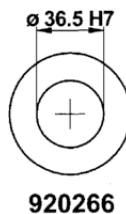
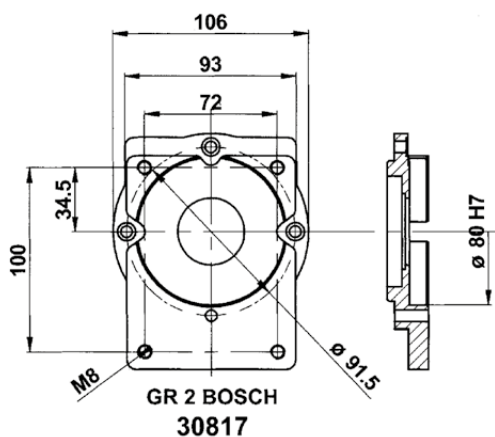
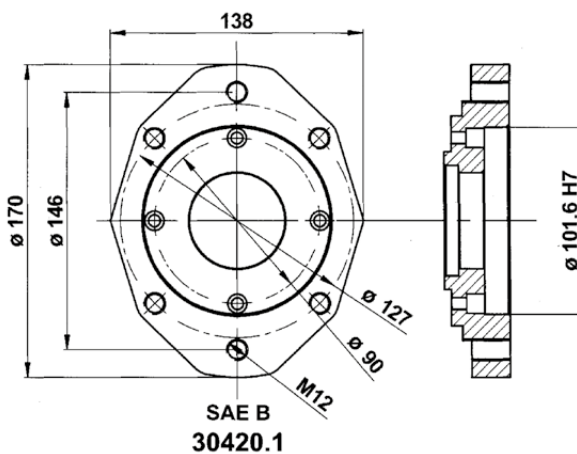
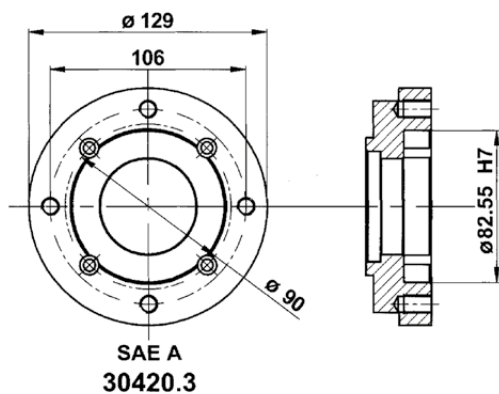
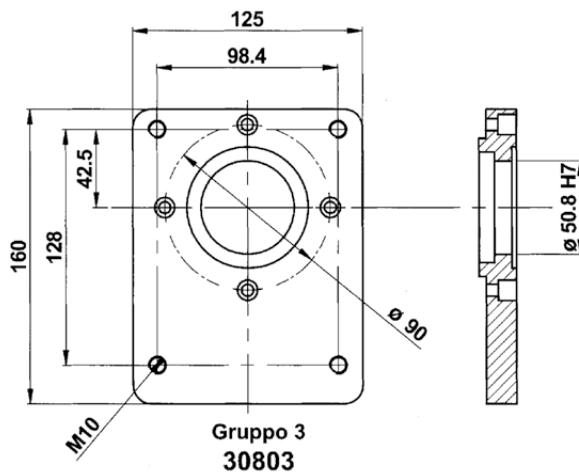
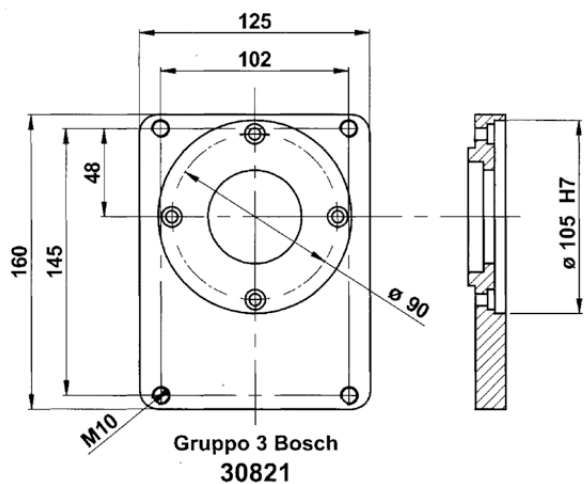

CODICE, CODE, CODE No., CODENUMMER					
Electric absorption	FLANGIA: TIPO, BRIDE: TYPE, FLANGE: TYPE, FLANSCHTYPE				
	Gr.2 BOSCH	Gr.3	Gr. 3 BOSCH	SAE A	SAE B
12 Volt	30933/2B	30935	30933/3B	30933/SA	30933/SB
24 Volt	30934/2B	30936	30934/3B	30934/SA	30934/SB





**OLEODINAMICA BORELLI**  
**HYDRAULIC COMPONENTS**

- TAVOLA RICAMBI INNESTO ELETTRIMAGNETICO 10daNm
- TABLEAU DES PIECES DETACHEES POUR EMBRAYAGE ELECTROMAGNETIQUE 10daNm
- SPARE PARTS TABLE FOR ELECTROMAGNETIC COUPLING 10daNm
- ERSATZTEILLISTE FUR ELEKTROMAGNETISCHE SCHALKUPPLUNGEN 10daNm

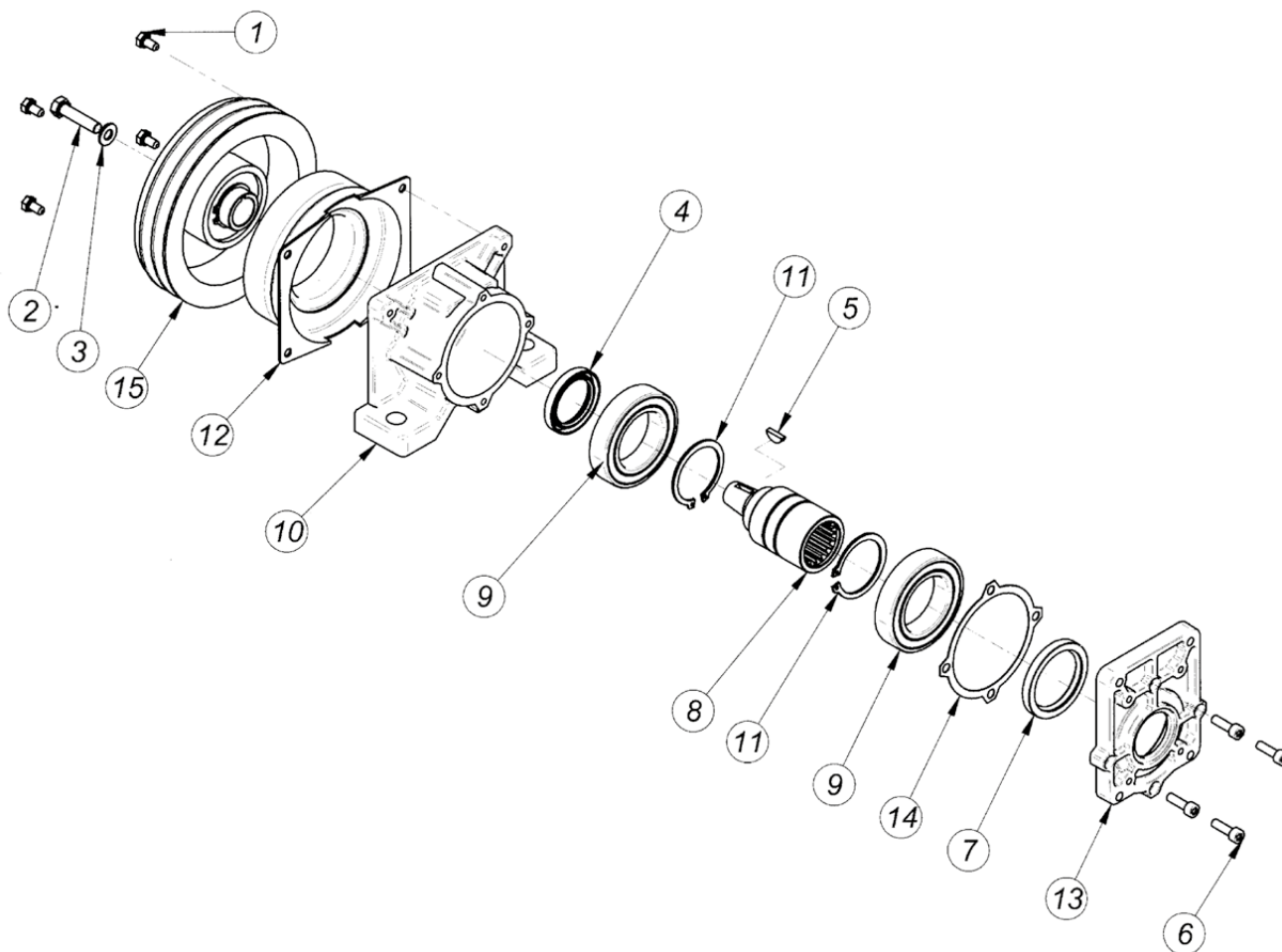

Pos.	CODICE	DENOMINAZIONE	DENOMINATION	DESCRIPTION	BEZEICHNUNG	Q.TA'
1	611428	Vite EN 24017 M6x12	Vis EN24017 M6x12	Soket EN 24017 M6x12	Befestigungsschraube EN 24017 M6x12	4
2	610516	Vite EN 24017 M8x35	Vis EN 24017 M8x35	Socket EN 24017 M8x35	Befestigungsschraube EN 24017 M8x35	1
3	RSPAL8	Rosetta per M8	Rondelle D.8	Washer d.8	Rosette durchm 8	1
4	303550	Anello di tenuta 35x50x7	Bague d'etancheite 35x50x7	Sealing ring 35x50x7	Dichtring 35x50x7	1
5	700465	Linguetta UNI 6606 4x6.5	Languette UNI 6606 4x6.5	Woodruff key UNI 6606 4x6.5	Halbrundkeil UNI 6606 4x6.5	1
6	610620	Vite T.C.E.I M6x20	Vis T.C.H.C. M6x20	Socket capscrew M6x20	Befestigungsschraube UNI 5931 M6x20	4
7	304560	Anello di tenuta 45x60x7	Bague d'etancheite 45x60x7	Sealing ring 45x60x7	Dichtring 45x60x7	1
8	A30901	Albero	Arbre	Shaft	Welle	1
9	506009/2Z	Cuscinetto 6009 2rs	Palier SKF 6009 2RS	Bearing SKF 6009 2RS	Kugellager SKF 6009-2RS	2
10	30009.1	Scatola	Carcasse	Housing	Gehäuse	1
11	904500	Anello elastico d.45	Circlip d.45	Snap ring d.45	Seegerring d.45	2
12	401210/153 402410/153	Bobina	Bobine	Coil	Zundspüle	1
13	30900.1	Flangia per pompe Gr 1 - 2	Flasque puor pompes Gr 1 - 2	Flange for pumps Gr 1 - 2	Flansch fur pompe Gr 1- 2	1
14	30009.1.1	Guarnizione	Joint	Gasket	Dichtung	1
15	4010/153P	Elettrofrizione	Electro-embayage	Electric clutch	Elektroschaltkplung	1



- **INNESTO ELETTROMAGNETICO 10daNm**
- **EMBRAYAGE ELECTROMAGNETIQUE 10daNm**
- **ELECTROMAGNETIC COUPLING 10daNm**
- **ELEKTROMAGNETISCHE SCHALKUPPLUNGEN 10daNm**

SERIE: 30901 12 Volt  
SERIE: 30903 24 Volt

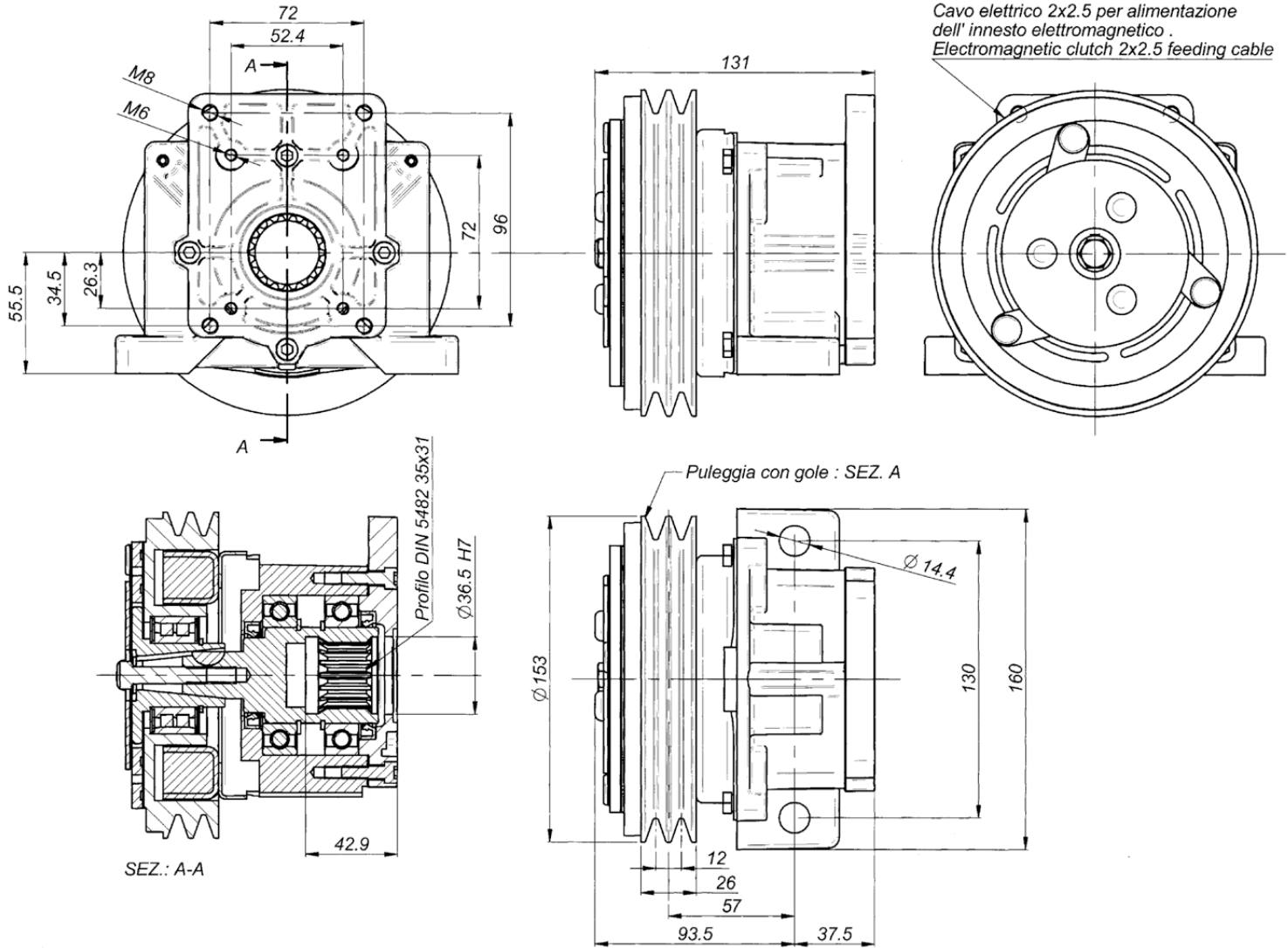

Nominal torque	7,8 daNm		Connection time	25 m/sec		
Static torque	12,5 daNm		Disconnection time	40 m/sec		
Dynamic torque	8,5 daNm	at 500 rpm	Minimum time between two connection	20 sec		
	7,0 daNm	at 1000 rpm				
	4,2 daNm	at 1500 rpm				
	3,5 daNm	at 2000 rpm	Max speed	5000 rpm		
	2,7 daNm	at 2500 rpm	Weight	5,5 Kg		
2,5 daNm	at 3000 rpm					
Electric absorption	Resistance ( $\Omega$ )		Current ( A )		Power ( W )	
	20° C	120° C	20° C	120° C	20° C	120° C
12 V DC	4,00	5,60	3,33	2,00	40,00	24,00
24 V DC	20,00	28,00	1,26	0,77	30,30	18,18

All technical data are at 20°C / at 120 °C the performance are less 20%  
All electromagneteic clutches are reversible.



- FLANGE PER INNESTI ELETTROMAGNETICI 10 daNm
- BRIDE POUR EMBRAYAGES ELECTROMAGNETIQUE 10 daNm
- FLANGES FOR ELECTROMAGNETIC COUPLING 10 daNm
- FLANSCHEN FÜR ELEKTROMAGNETISCHE SCHALT Kupplungen 10 daNm

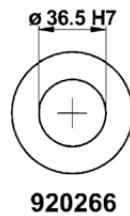
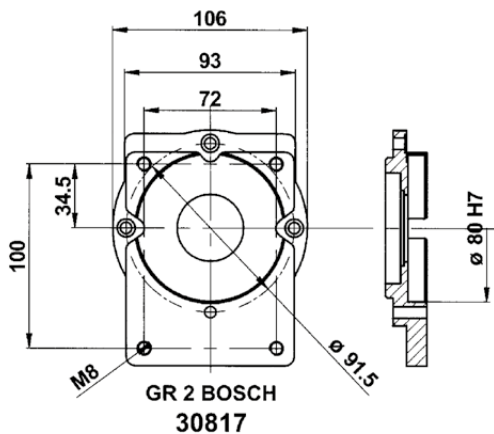
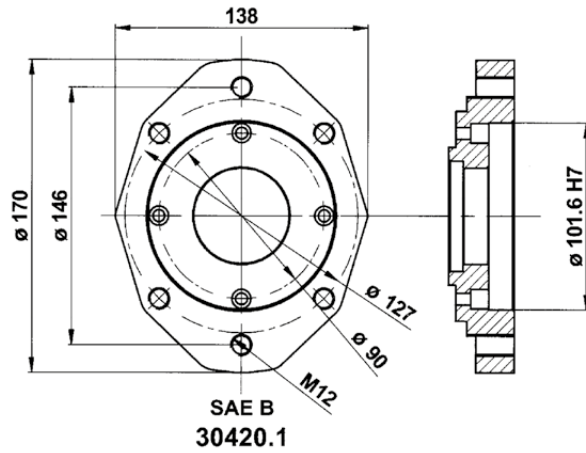
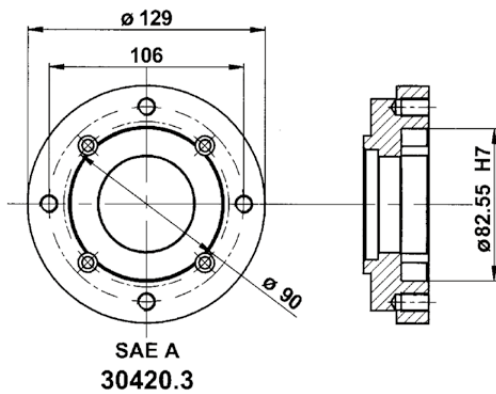
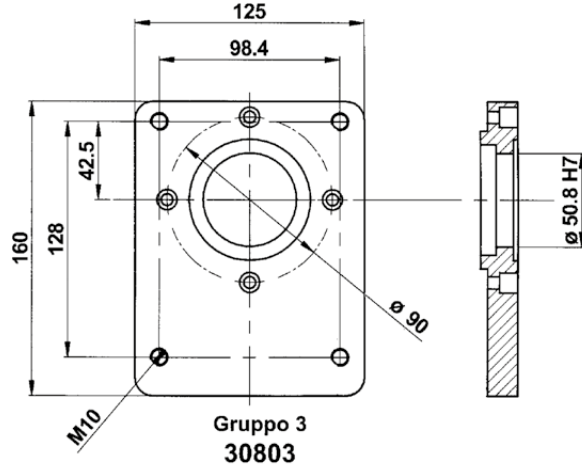
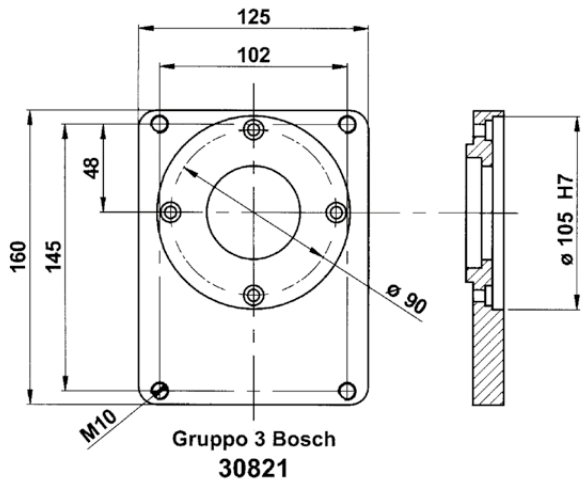

CODICE, CODE, CODE No., CODENUMMER					
Electric absorption	FLANGIA: TIPO, BRIDE: TYPE, FLANGE: TYPE, FLANSCHTYPE				
	Gr.2 BOSCH	Gr.3	Gr. 3 BOSCH	SAE A	SAE B
12 Volt	30917	30909	30925	30901/SA	30901/SB
24 Volt	30919	30911	30927	30903/SA	30903/SB







**OLEODINAMICA BORELLI**  
**HYDRAULIC COMPONENTS**

- TAVOLA RICAMBI INNESTO ELETTROMAGNETICO 10daNm PULEGGIA PLV
- TABLEAU DES PIECES DETACHEES POUR EMBRAYAGE ELECTROMAGNETIQUE 10daNm POULIE PLV
- SPARE PARTS TABLE FOR ELECTROMAGNETIC COUPLING 10daNm PLV PULLEY
- ERSATZTEILLISTE FUR ELEKTROMAGNETISCHE SCHALTKUPPLUNGEN 10daNm PLV

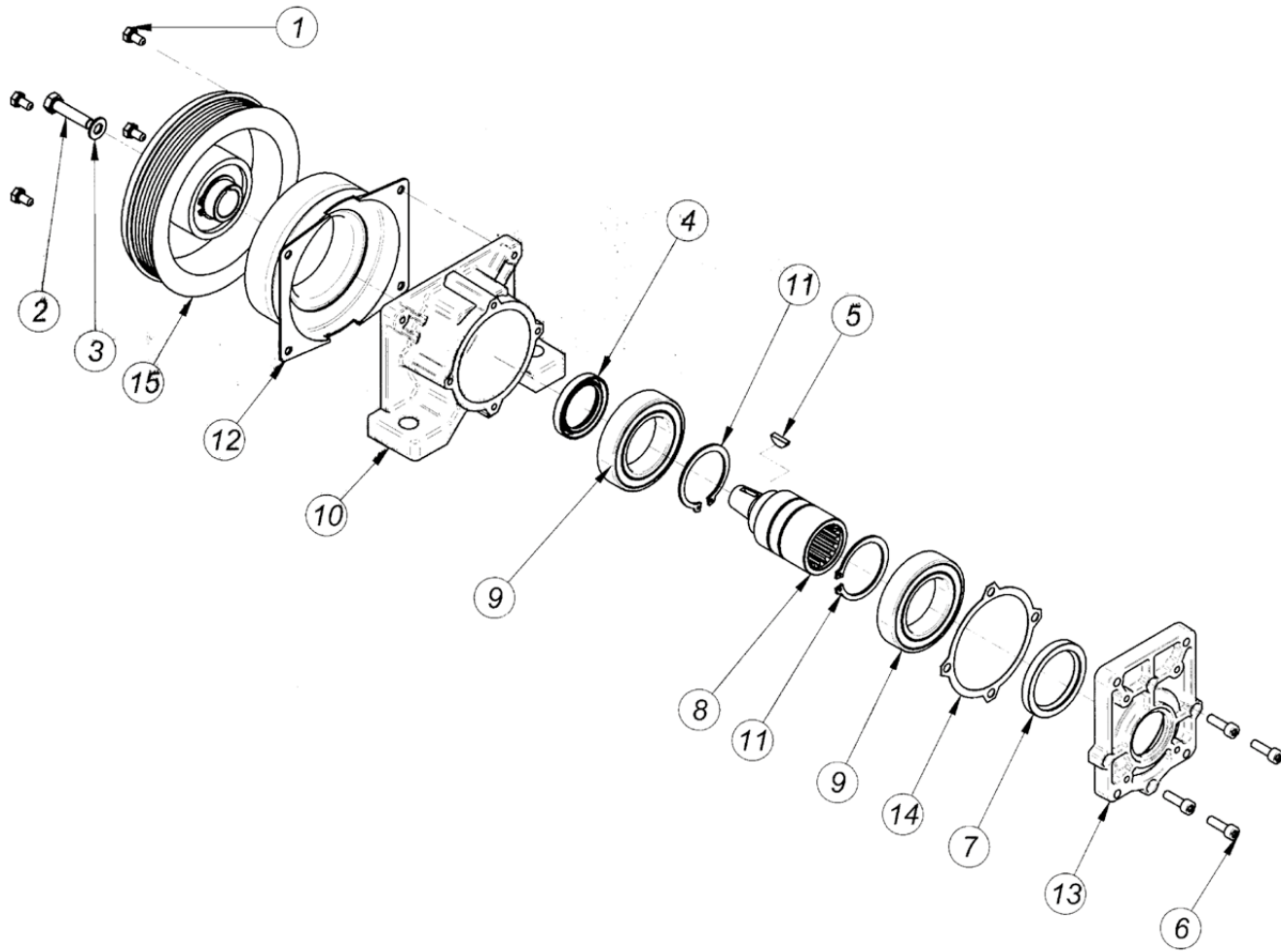

Pos.	CODICE	DENOMINAZIONE	DENOMINATION	DESCRIPTION	BEZEICHNUNG	Q.TA'
1	611428	Vite EN 24017 M6x12	Vis EN24017 M6x12	Soket EN 24017 M6x12	Befestigungsschraube EN 24017 M6x12	4
2	610516	Vite EN 24017 M8x35	Vis EN 24017 M8x35	Socket EN 24017 M8x35	Befestigungsschraube EN 24017 M8x35	1
3	RSPAL8	Rosetta per M8	Rondelle D.8	Washer d.8	Rosette durchm 8	1
4	303550	Anello di tenuta 35x50x7	Bague d'etancheite 35x50x7	Sealing ring 35x50x7	Dichtring 35x50x7	1
5	700465	Linguetta UNI 6606 4x6.5	Languette UNI 6606 4x6.5	Woodruff key UNI 6606 4x6.5	Halbrundkeil UNI 6606 4x6.5	1
6	610620	Vite T.C.E.I M6x20	Vis T.C.H.C. M6x20	Socket capscREW M6x20	Befestigungsschraube UNI 5931 M6x20	4
7	304560	Anello di tenuta 45x60x7	Bague d'etancheite 45x60x7	Sealing ring 45x60x7	Dichtring 45x60x7	1
8	A30901	Albero	Arbre	Shaft	Welle	1
9	506009/2Z	Cuscinetto 6009 2rs	Palier SKF 6009 2RS	Bearing SKF 6009 2RS	Kugellager SKF 6009-2RS	2
10	30009.1	Scatola	Carcasse	Housing	Gehäuse	1
11	904500	Anello elastico d.45	Circlip d.45	Snap ring d.45	Seegerring d.45	2
12	401210/PLV 402410/PLV	Bobina	Bobine	Coil	Zundspule	1
13	30900.1	Flangia per pompe Gr 1 - 2	Flasque puor pompes Gr 1 - 2	Flange for pumps Gr 1 - 2	Flansch fur pumpe Gr 1- 2	1
14	30009.1.1	Guarnizione	Joint	Gasket	Dichtung	1
15	4010/PLV	Elettrofrizione PLV	Electro-embayage PLV	Electric clutch PLV	Elektroschaltkpllung PLV	1



- **INNESTO ELETTROMAGNETICO 10daNm PULEGGIA PLV**
  - *EMBRAYAGE ELECTROMAGNETIQUE 10daNm POULIE PLV*
  - *ELECTROMAGNETIC COUPLING 10daNm PLV PULLEY*
  - *ELEKTROMAGNETISCHE SCHALTKUPPLUNGEN 10daNm PLV*

SERIE: 30901-1/7 12 Volt

SERIE: 30903-1/7 24 Volt

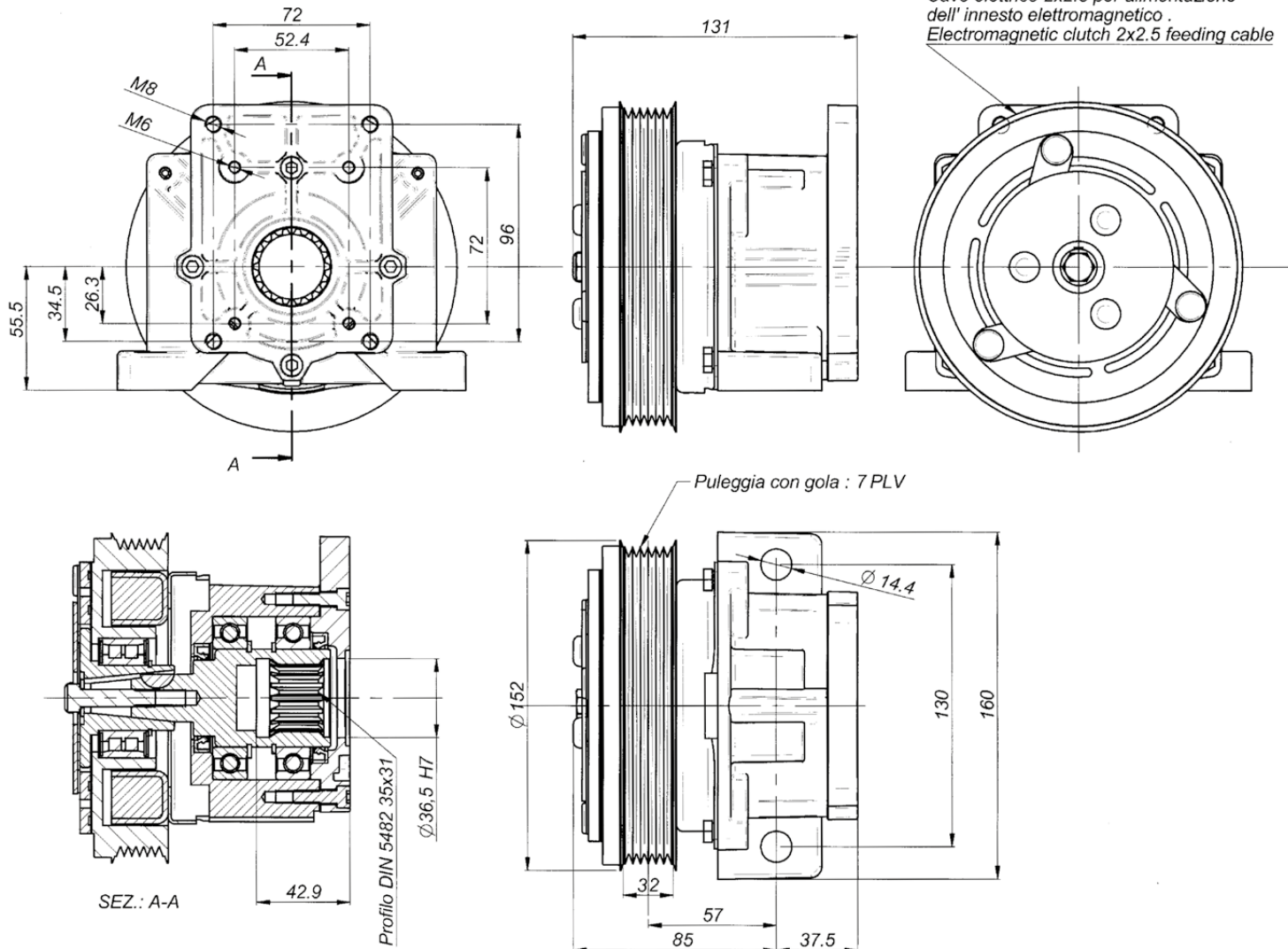

Nominal torque	7,8 daNm		Connection time	25 m/sec		
Static torque	12,5 daNm		Disconnection time	40 m/sec		
Dynamic torque	8,5 daNm	at 500 rpm	Minimun time between two connection	20 sec		
	7,0 daNm	at 1000 rpm				
	4,2 daNm	at 1500 rpm				
	3,5 daNm	at 2000 rpm	Max speed	5000 rpm		
	2,7 daNm	at 2500 rpm	Weight	5,5 Kg		
	2,5 daNm	at 3000 rpm				
Electric absorption	Resistance ( $\Omega$ )		Current ( A )		Power ( W )	
	20° C	120° C	20° C	120° C	20° C	120° C
12 V DC	4,00	5,60	3,33	2,00	40,00	24,00
24 V DC	20,00	28,00	1,26	0,77	30,30	18,18
All technical data are at 20°C / at 120 °C the performance are less 20% All electromagetic clutches are reversible.						



- FLANGE PER INNESTI ELETTROMAGNETICI 10 daNm
- BRIDE POUR EMBRAYAGES ELECTROMAGNETIQUE 10 daNm
- FLANGES FOR ELECTROMAGNETIC COUPLING 10 daNm
- FLANSCHEN FÜR ELEKTROMAGNETISCHE SCHALT Kupplungen 10 daNm

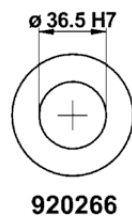
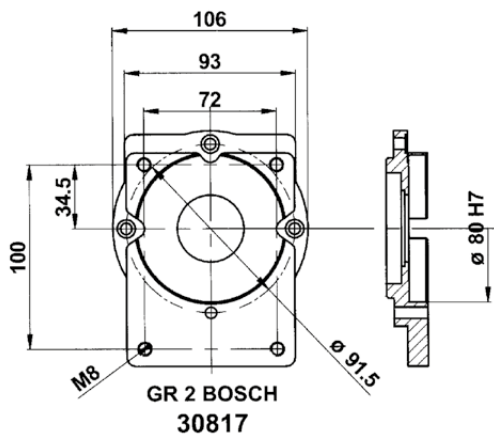
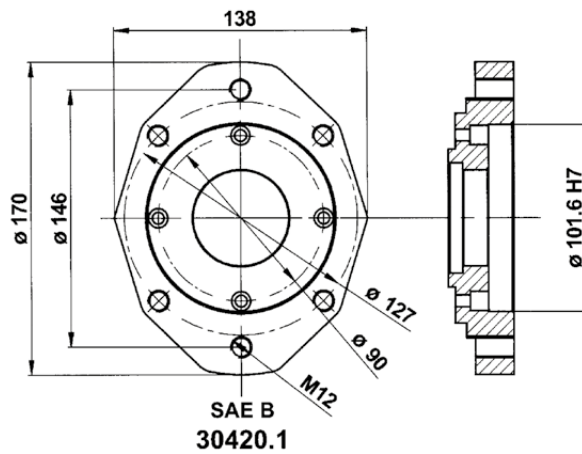
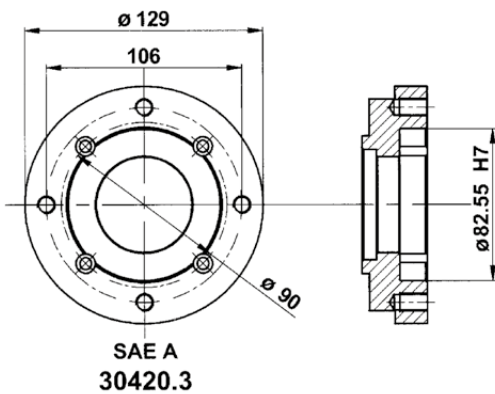
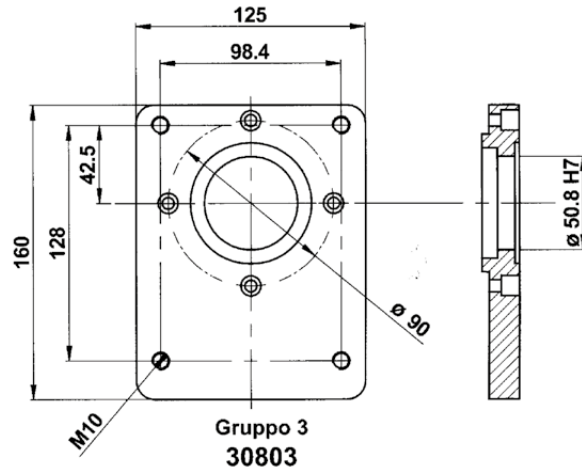
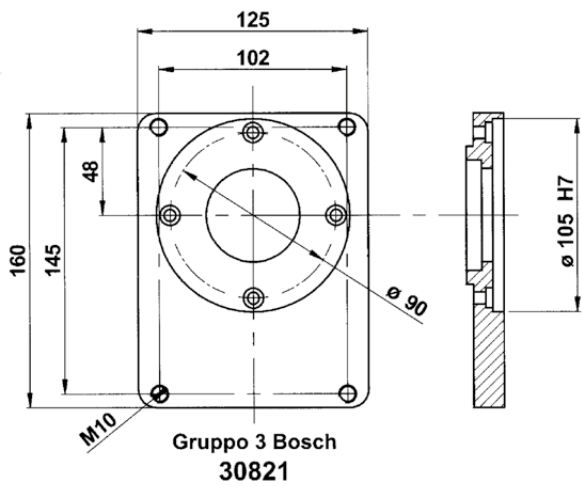

CODICE, CODE, CODE No., CODENUMMER

Electric absorption	FLANGIA: TIPO, BRIDE: TYPE, FLANGE: TYPE, FLANSCHTYPE				
	Gr.2 BOSCH	Gr.3	Gr. 3 BOSCH	SAE A	SAE B
12 Volt	30917-1	30909-1	30925-1	30901-1/SA	30901-1/SB
24 Volt	30919-1	30911-1	30927-1	30903-1/SA	30903-1/SB





**OLEODINAMICA BORELLI**  
**HYDRAULIC COMPONENTS**

- TAVOLA RICAMBI INNESTO ELETTROMAGNETICO 14daNm
- TABLEAU DES PIECES DETACHEES POUR EMBRAYAGE ELECTROMAGNETIQUE 14daNm
- SPARE PARTS TABLE FOR ELECTROMAGNETIC COUPLING 14daNm
- ERSATZTEILLISTE FUR ELEKTROMAGNETISCHE SCHALKUPPLUNGEN 14daNm

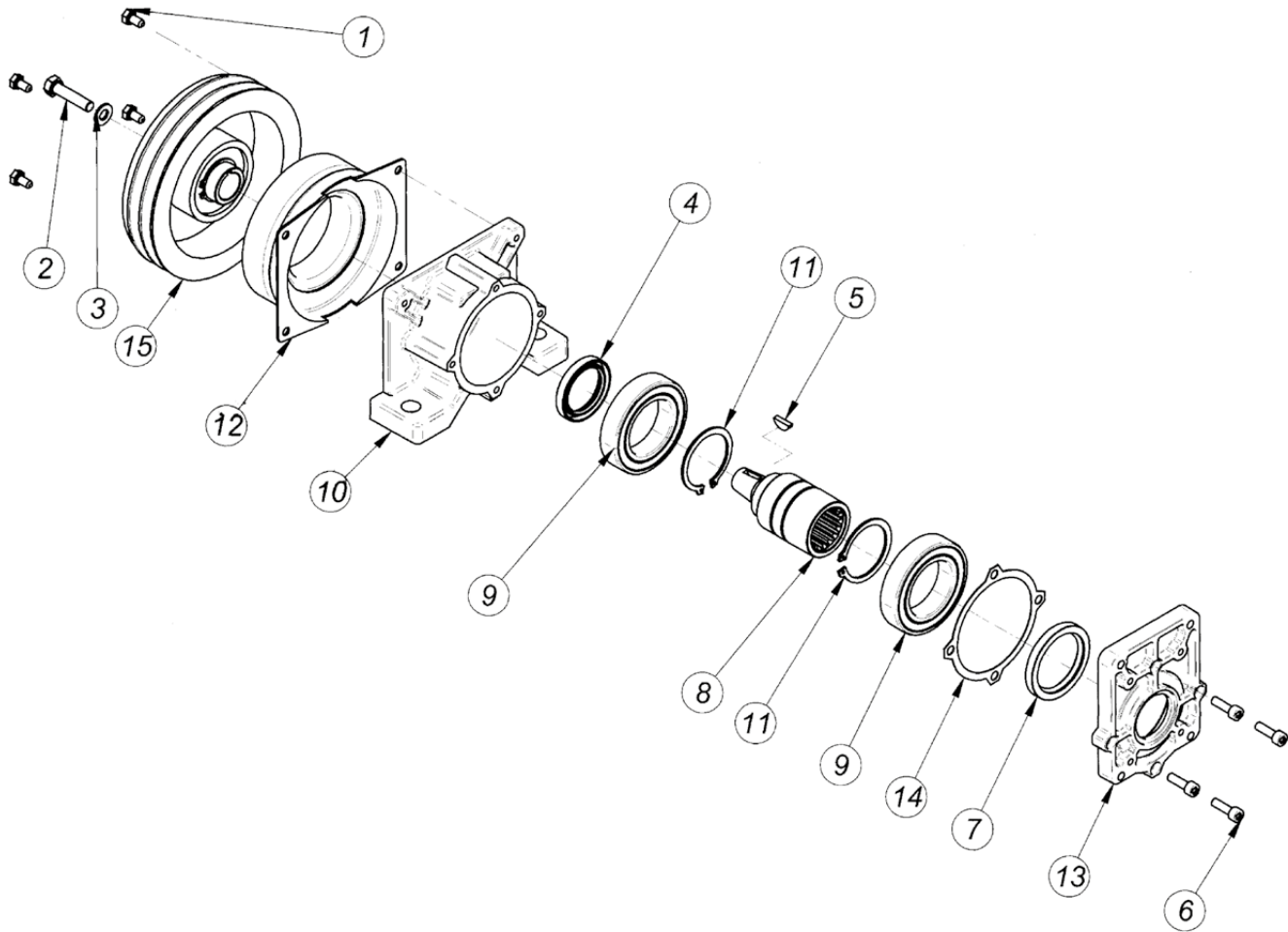

Pos.	CODICE	DENOMINAZIONE	DENOMINATION	DESCRIPTION	BEZEICHNUNG	Q.TA'
1	611428	Vite EN 24017 M6x12	Vis EN24017 M6x12	Soket EN 24017 M6x12	Befestigungsschraube EN 24017 M6x12	4
2	610516	Vite EN 24017 M8x35	Vis EN 24017 M8x35	Socket EN 24017 M8x35	Befestigungsschraube EN 24017 M8x35	1
3	RSPAL8	Rosetta per M8	Rondelle D.8	Washer d.8	Rosette durchm 8	1
4	303550	Anello di tenuta 35x50x7	Bague d'etancheite 35x50x7	Sealing ring 35x50x7	Dichtring 35x50x7	1
5	700465	Linguetta UNI 6606 4x6.5	Languette UNI 6606 4x6.5	Woodruff key UNI 6606 4x6.5	Halbrundkeil UNI 6606 4x6.5	1
6	610620	Vite T.C.E.I M6x20	Vis T.C.H.C. M6x20	Socket capscrew M6x20	Befestigungsschraube UNI 5931 M6x20	4
7	304560	Anello di tenuta 45x60x7	Bague d'etancheite 45x60x7	Sealing ring 45x60x7	Dichtring 45x60x7	1
8	A30901	Albero	Arbre	Shaft	Welle	1
9	506009/2Z	Cuscinetto 6009 2rs	Palier SKF 6009 2RS	Bearing SKF 6009 2RS	Kugellager SKF 6009-2RS	2
10	30009.1	Scatola	Carcasse	Housing	Gehause	1
11	904500	Anello elastico d.45	Circlip d.45	Snap ring d.45	Seegerring d.45	2
12	401214/153 402414/153	Bobina	Bobine	Coil	Zundspule	1
13	30900.1	Flangia per pompe Gr 1 - 2	Flasque puor pompes Gr 1 - 2	Flange for pumps Gr 1 - 2	Flansch fur pumpe Gr 1 - 2	1
14	30009.1.1	Guarnizione	Joint	Gasket	Dichtung	1
15	4014/153P	Elettrofrizione	Electro-embayage	Electric clutch	Elektroschaltkplung	1



- **INNESTO ELETTRIMAGNETICO 14daNm**
- **EMBAYAGE ELECTROMAGNETIQUE 14daNm**
- **ELECTROMAGNETIC COUPLING 14daNm**
- **ELEKTROMAGNETISCHE SCHALKUPPLUNGEN 14daNm**

SERIE: 30929 12 Volt

SERIE: 30930 24 Volt

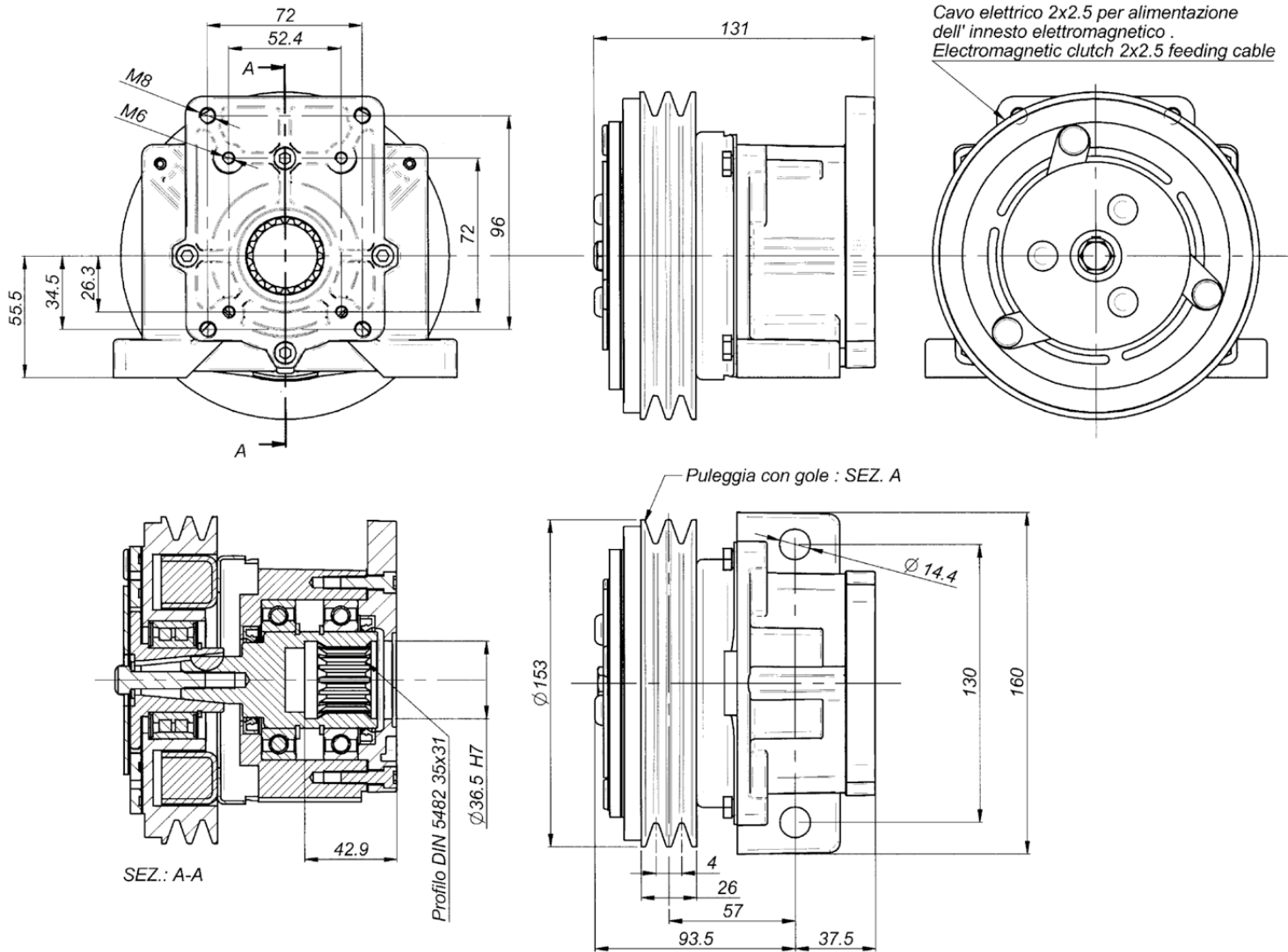

Nominal torque	11,8 daNm		Connection time	25 m/sec		
Static torque	14,0 daNm		Disconnection time	40 m/sec		
Dynamic torque	12,5 daNm	at 500 rpm	Minimum time between two connection	20 sec		
	11,0 daNm	at 1000 rpm				
	8,2 daNm	at 1500 rpm				
	7,5 daNm	at 2000 rpm	Max speed	5000 rpm		
	6,7 daNm	at 2500 rpm	Weight	5,5 Kg		
	6,5 daNm	at 3000 rpm				
Electric absorption	Resistance ( $\Omega$ )		Current ( A )		Power ( W )	
	20° C	120° C	20° C	120° C	20° C	120° C
12 V DC	4,00	5,60	3,33	2,00	40,00	24,00
24 V DC	20,00	28,00	1,26	0,77	30,30	18,18
All technical data are at 20°C / at 120 °C the performance are less 20% All electromagneteic clutches are reversible.						



- FLANGE PER INNESTI ELETTRICITÀ 14 daNm
- BRIDE POUR EMBRAYAGES ELECTROMAGNETIQUE 14 daNm
- FLANGES FOR ELECTROMAGNETIC COUPLING 14 daNm
- FLANSCHEN FÜR ELEKTROMAGNETISCHE SCHALTKUPPLUNGEN 14 daNm

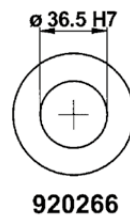
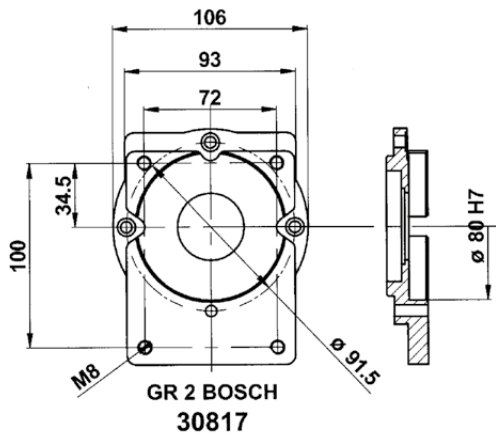
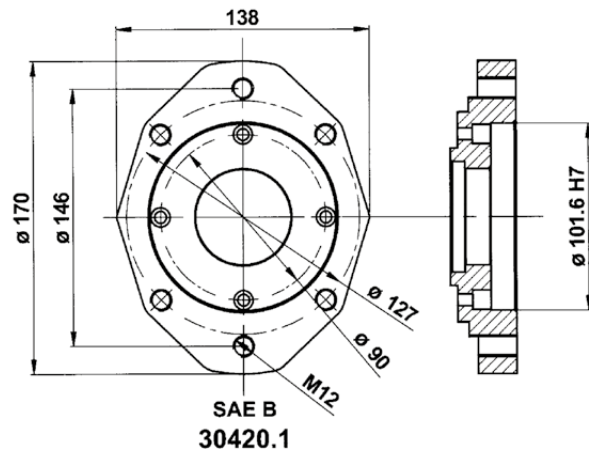
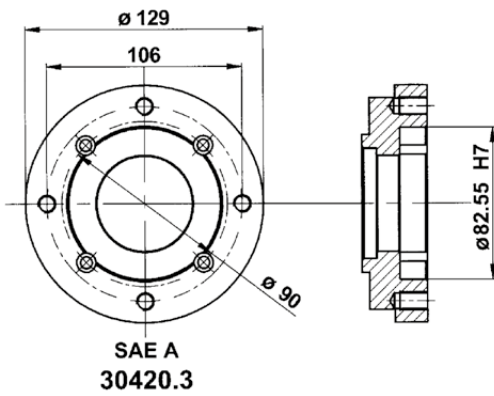
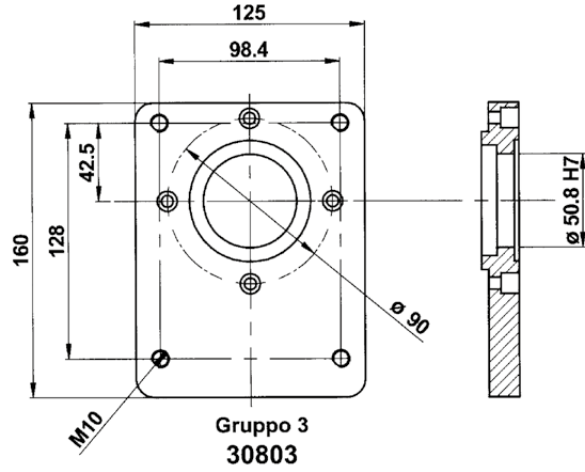
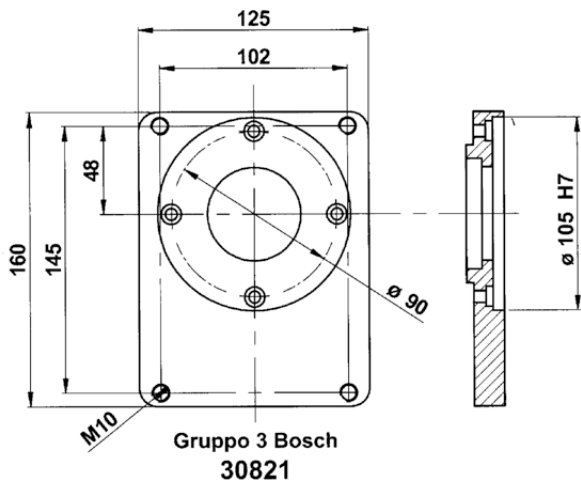

CODICE, CODE, CODE No., CODENUMMER					
Electric absorption	FLANGIA: TIPO, BRIDE: TYPE, FLANGE: TYPE, FLANSCHTYPE				
	Gr.2 BOSCH	Gr.3	Gr. 3 BOSCH	SAE A	SAE B
12 Volt	30929/2B	30931	30931/3B	30929/SA	30929/SB
24 Volt	30930/2B	30932	30932/3B	30930/SA	30930/SB







**OLEODINAMICA BORELLI**  
**HYDRAULIC COMPONENTS**

- TAVOLA RICAMBI INNESTO ELETTROMAGNETICO 14daNm
- TABLEAU DES PIECES DETACHEES POUR EMBRAYAGE ELECTROMAGNETIQUE 14daNm
- SPARE PARTS TABLE FOR ELECTROMAGNETIC COUPLING 14daNm
- ERSATZTEILLISTE FUR ELEKTROMAGNETISCHE SCHALKUPPLUNGEN 14daNm

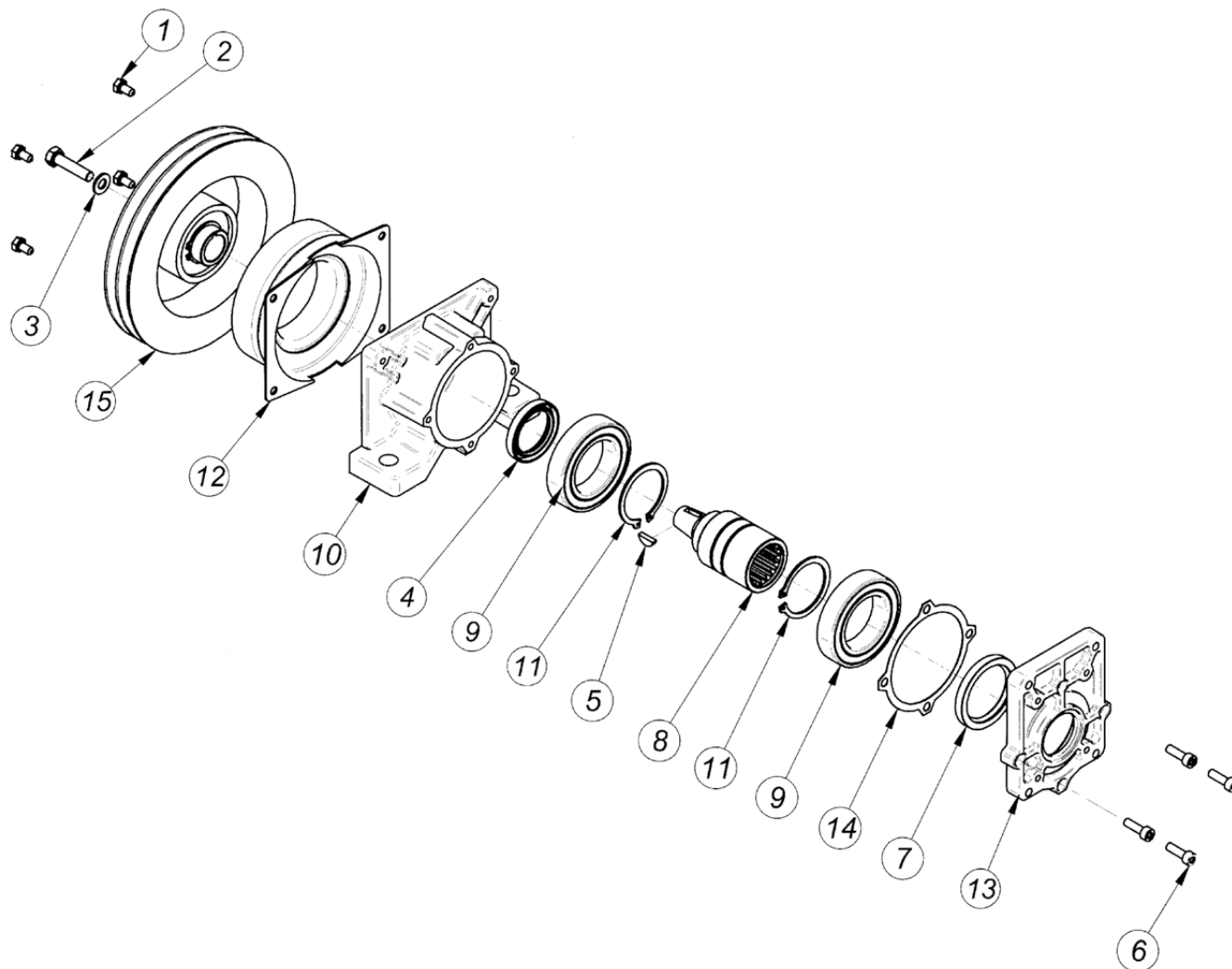

Pos.	CODICE	DENOMINAZIONE	DENOMINATION	DESCRIPTION	BEZEICHNUNG	Q. TA'
1	611428	Vite EN 24017 M6x12	Vis EN24017 M6x12	Soket EN 24017 M6x12	Befestigungsschraube EN 24017 M6x12	4
2	610516	Vite EN 24017 M8x35	Vis EN 24017 M8x35	Socket EN 24017 M8x35	Befestigungsschraube EN 24017 M8x35	1
3	RSPAL8	Rosetta per M8	Rondelle D.8	Washer d.8	Rosette durchm 8	1
4	303550	Anello di tenuta 35x50x7	Bague d'etancheite 35x50x7	Sealing ring 35x50x7	Dichtring 35x50x7	1
5	700465	Linguetta UNI 6606 4x6.5	Languette UNI 6606 4x6.5	Woodruff key UNI 6606 4x6.5	Halbrundkeil UNI 6606 4x6.5	1
6	610620	Vite T.C.E.I M6x20	Vis T.C.H.C. M6x20	Socket capscREW M6x20	Befestigungsschraube UNI 5931 M6x20	4
7	304560	Anello di tenuta 45x60x7	Bague d'etancheite 45x60x7	Sealing ring 45x60x7	Dichtring 45x60x7	1
8	A30901	Albero	Arbre	Shaft	Welle	1
9	506009/2Z	Cuscinetto 6009 2rs	Palier SKF 6009 2RS	Bearing SKF 6009 2RS	Kugellager SKF 6009-2RS	2
10	30009.1	Scatola	Carcasse	Housing	Gehäuse	1
11	904500	Anello elastico d.45	Circlip d.45	Snap ring d.45	Seegerring d.45	2
12	401214/175 402414/175	Bobina	Bobine	Coil	Zundspüle	1
13	30900.1	Flangia per pompe Gr 1 - 2	Flasque puor pompes Gr 1 - 2	Flange for pumps Gr 1 - 2	Flansch fur pumpe Gr 1- 2	1
14	30009.1.1	Guarnizione	Joint	Gasket	Dichtung	1
15	4014/175P	Elettrofrizione	Electro-embayage	Electric clutch	Elektroschaltkupplung	1



- **INNESTO ELETTROMAGNETICO 14daNm**
- **EMBAYAGE ELECTROMAGNETIQUE 14daNm**
- **ELECTROMAGNETIC COUPLING 14daNm**
- **ELEKTROMAGNETISCHE SCHALKUPPLUNGEN 14daNm**

SERIE: 30980 12 Volt

SERIE: 30981 24 Volt

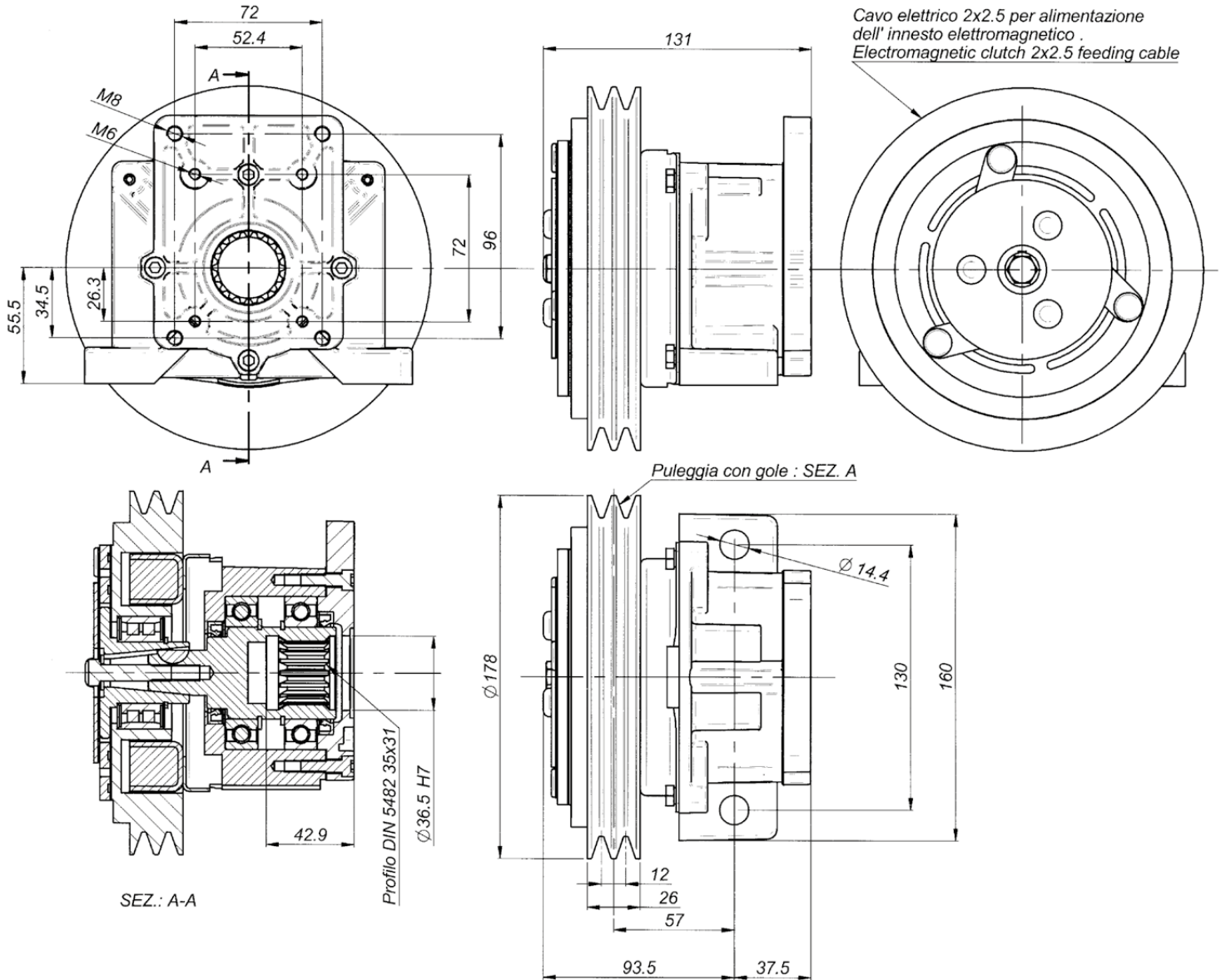

Nominal torque	11,8 daNm		Connection time	25 m/sec		
Static torque	14,0 daNm		Disconnection time	40 m/sec		
Dynamic torque	12,5 daNm	at 500 rpm	Minimum time between two connection	20 sec		
	11,0 daNm	at 1000 rpm				
	8,2 daNm	at 1500 rpm				
	7,5 daNm	at 2000 rpm	Max speed	5000 rpm		
	6,7 daNm	at 2500 rpm	Weight	5,8 Kg		
6,5 daNm	at 3000 rpm					
Electric absorption	Resistance ( $\Omega$ )		Current ( A )		Power ( W )	
	20° C	120° C	20° C	120° C	20° C	120° C
12 V DC	4,00	5,60	3,33	2,00	40,00	24,00
24 V DC	20,00	28,00	1,26	0,77	30,30	18,18
All technical data are at 20°C / at 120 °C the performance are less 20% All electromagneteic clutches are reversible.						

- FLANGE PER INNESTI ELETTROMAGNETICI 14 daNm
- BRIDE POUR EMBRAYAGES ELECTROMAGNETIQUE 14 daNm
- FLANGES FOR ELECTROMAGNETIC COUPLING 14 daNm
- FLANSCHEN FÜR ELEKTROMAGNETISCHE SCHALKUPPLUNGEN 14 daNm

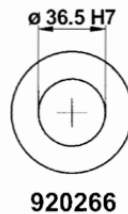
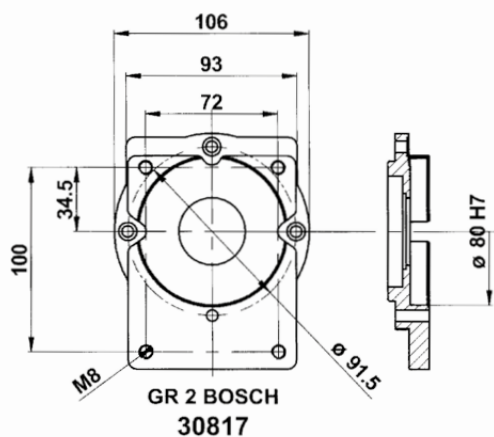
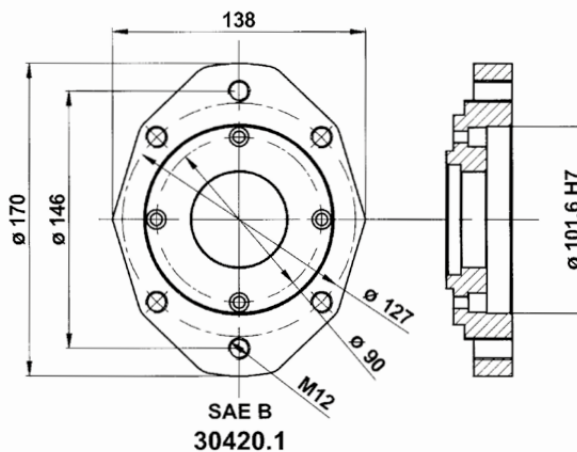
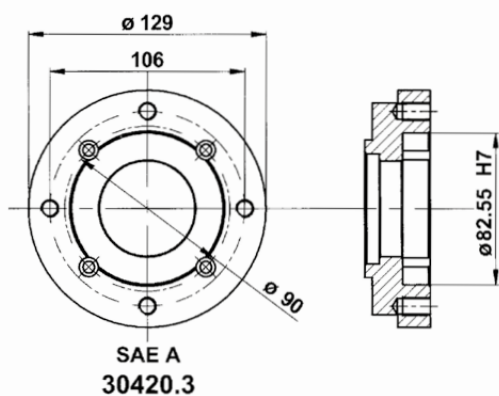
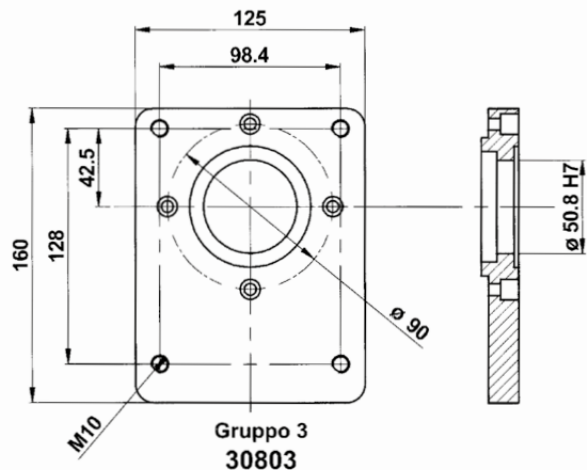
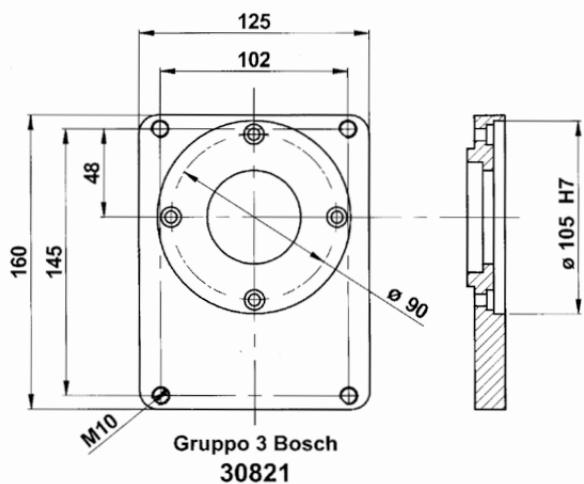

CODICE, CODE, CODE No., CODENUMMER

Electric absorption	FLANGIA: TIPO, BRIDE: TYPE, FLANGE: TYPE, FLANSCHTYPE				
	Gr.2 BOSCH	Gr.3	Gr. 3 BOSCH	SAE A	SAE B
12 Volt	30980/2B	30982	30982/3B	30980/SA	30980/SB
24 Volt	30981/2B	30983	30982/3B	30981/SA	30981/SB





- TAVOLA RICAMBI INNESTO ELETTROMAGNETICO 14daNm PULEGGIA PLV
- TABLEAU DES PIECES DETACHEES POUR EMBRAYAGE ELECTROMAGNETIQUE 14daNm POULIE PLV
- SPARE PARTS TABLE FOR ELECTROMAGNETIC COUPLING 14daNm PLV PULLEY
- ERSATZTEILLISTE FUR ELEKTROMAGNETISCHE SCHALKUPPLUNGEN 14daNm PLV

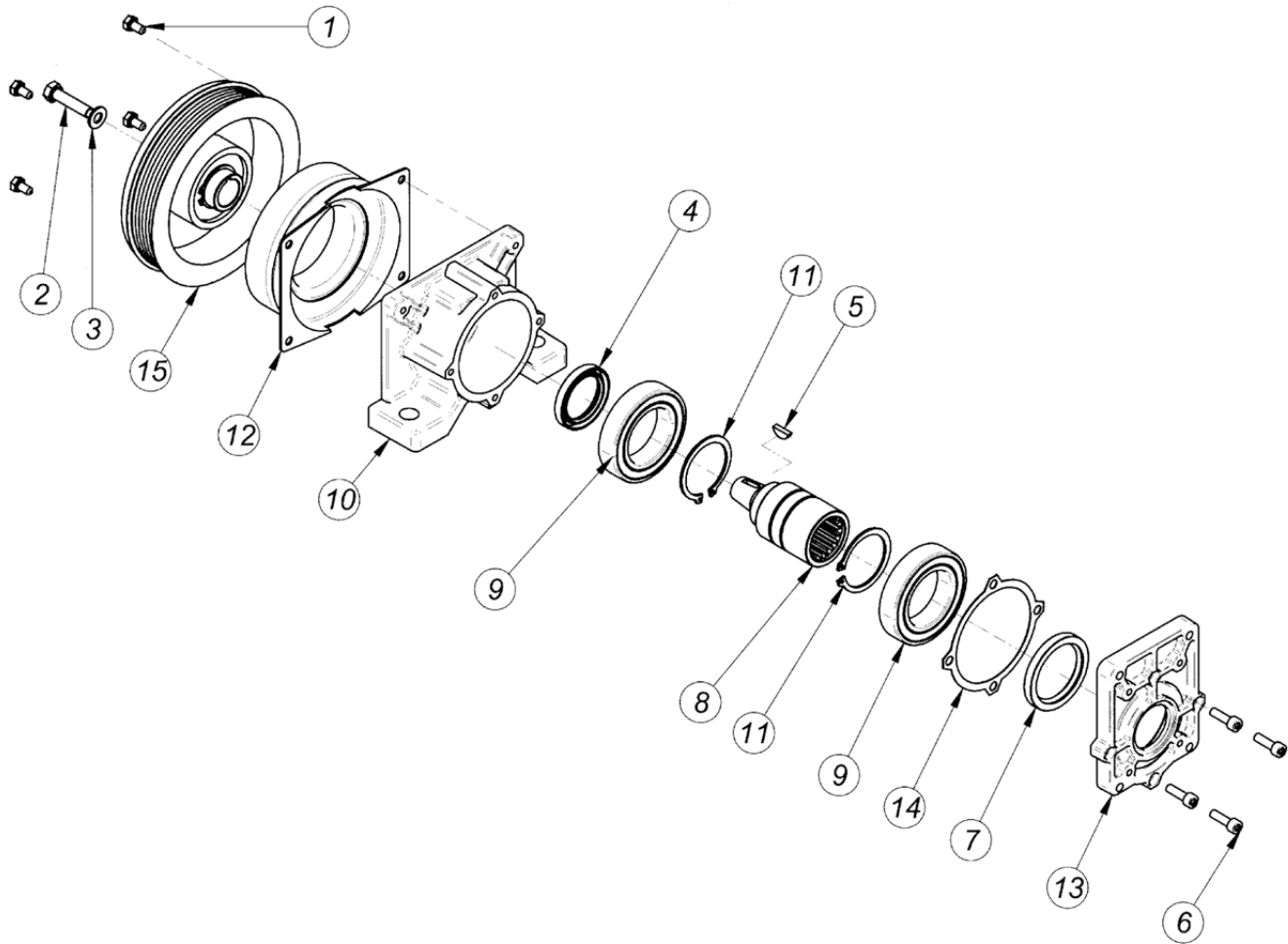

Pos.	CODICE	DENOMINAZIONE	DENOMINATION	DESCRIPTION	BEZEICHNUNG	Q. TA'
1	611428	Vite EN 24017 M6x12	Vis EN24017 M6x12	Soket EN 24017 M6x12	Befestigungsschraube EN 24017 M6x12	4
2	610516	Vite EN 24017 M8x35	Vis EN 24017 M8x35	Socket EN 24017 M8x35	Befestigungsschraube EN 24017 M8x35	1
3	RSPAL8	Rosetta per M8	Rondelle D.8	Washer d.8	Rosette durchm 8	1
4	303550	Anello di tenuta 35x50x7	Bague d'etancheite 35x50x7	Sealing ring 35x50x7	Dichtring 35x50x7	1
5	700465	Linguetta UNI 6606 4x6.5	Languette UNI 6606 4x6.5	Woodruff key UNI 6606 4x6.5	Halbrundkeil UNI 6606 4x6.5	1
6	610620	Vite T.C.E.I M6x20	Vis T.C.H.C. M6x20	Socket capscrew M6x20	Befestigungsschraube UNI 5931 M6x20	4
7	304560	Anello di tenuta 45x60x7	Bague d'etancheite 45x60x7	Sealing ring 45x60x7	Dichtring 45x60x7	1
8	A30901	Albero	Arbre	Shaft	Welle	1
9	506009/2Z	Cuscinetto 6009 2rs	Palier SKF 6009 2RS	Bearing SKF 6009 2RS	Kugellager SKF 6009-2RS	2
10	30009.1	Scatola	Carcasse	Housing	Gehäuse	1
11	904500	Anello elastico d.45	Circlip d.45	Snap ring d.45	Seegerring d.45	2
12	401214/PLV 402414/PLV	Bobina	Bobine	Coil	Zundspüle	1
13	30900.1	Flangia per pompe Gr 1 - 2	Flasque puor pompes Gr 1 - 2	Flange for pumps Gr 1 - 2	Flansch fur pumpe Gr 1- 2	1
14	30009.1.1	Guarnizione	Joint	Gasket	Dichtung	1
15	4014/PLVP	Elettrofrizione PLV	Electro-embayage PLV	Electric clutch PLV	Elektroschaltkupplung PLV	1



- **INNESTO ELETTROMAGNETICO 14daNm PULEGGIA PLV**
  - *EMBAYAGE ELECTROMAGNETIQUE 14daNm POULIE PLV*
  - *ELECTROMAGNETIC COUPLING 14daNm PLV PULLEY*
  - *ELEKTROMAGNETISCHE SCHALKUPPLUNGEN 14daNm PLV*

SERIE: 30929-1/7 12 Volt  
SERIE: 30930-1/7 24 Volt

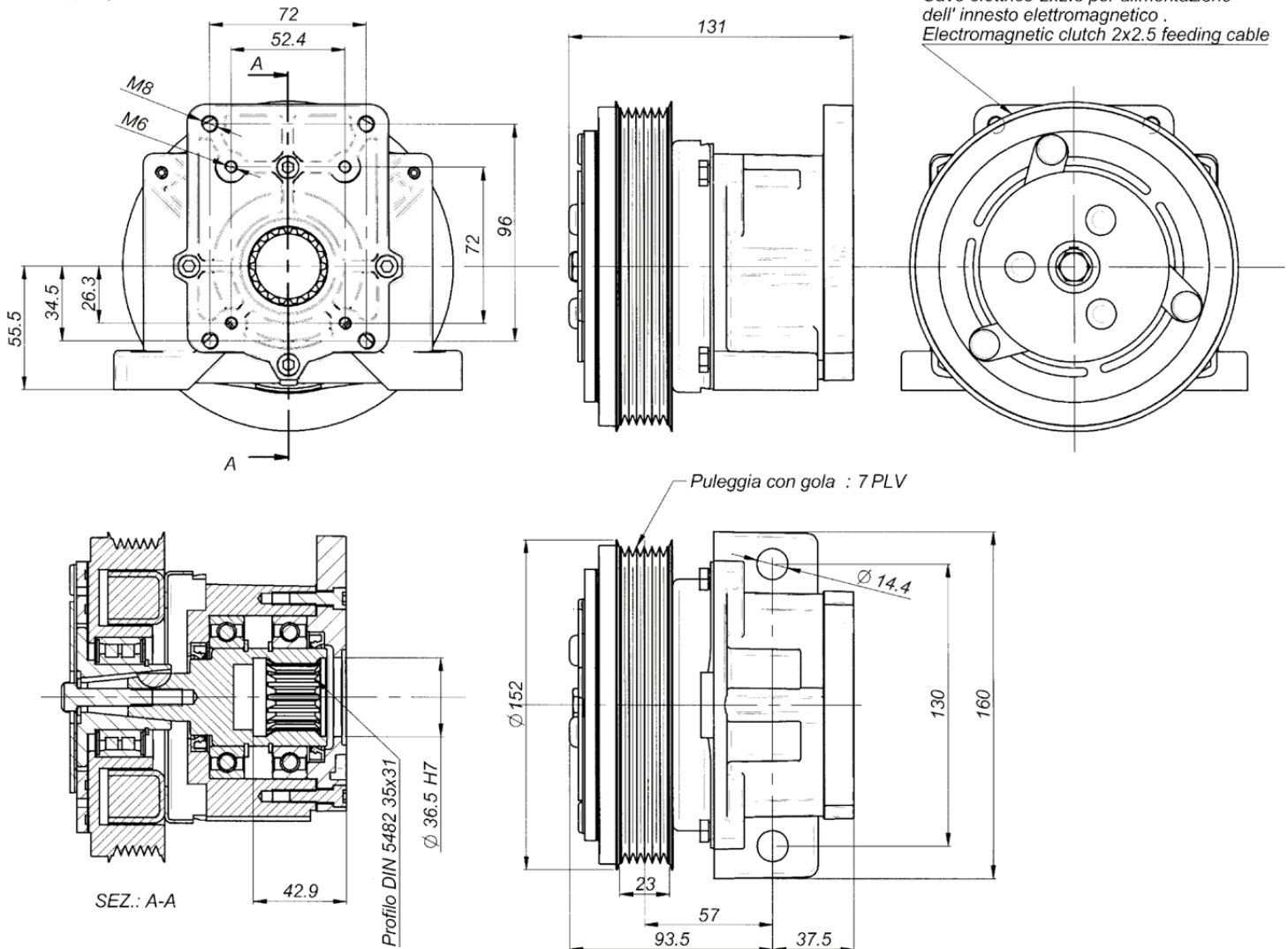

Cavo elettrico 2x2.5 per alimentazione dell' innesto elettromagnetico.  
Electromagnetic clutch 2x2.5 feeding cable

Puleggia con gola : 7 PLV

Profilo DIN 5482 35x31  
Ø 36.5 H7

SEZ.: A-A

Nominal torque	11,8 daNm		Connection time	25 m/sec		
Static torque	14,0 daNm		Disconnection time	40 m/sec		
Dynamic torque	12,5 daNm	at 500 rpm	Minimun time between two connection	20 sec		
	11,0 daNm	at 1000 rpm				
	8,2 daNm	at 1500 rpm				
	7,5 daNm	at 2000 rpm	Max speed	5000 rpm		
	6,7 daNm	at 2500 rpm	Weight	5,5 Kg		
	6,5 daNm	at 3000 rpm				
Electric absorption	Resistance ( Ω )		Current ( A )		Power ( W )	
	20° C	120° C	20° C	120° C	20° C	120° C
12 V DC	4,00	5,60	3,33	2,00	40,00	24,00
24 V DC	20,00	28,00	1,26	0,77	30,30	18,18

All technical data are at 20°C / at 120 °C the performance are less 20%  
All electromagneteic clutches are reversible.



**OLEODINAMICA BORELLI**  
**HYDRAULIC COMPONENTS**

- FLANGE PER INNESTI ELETTRICOMAGNETICI 14 daNm PLV
- BRIDE POUR EMBRAYAGES ELECTROMAGNETIQUE 14 daNm PLV
- FLANGES FOR ELECTROMAGNETIC COUPLING 14 daNm PLV
- FLANSCHEN FÜR ELEKTROMAGNETISCHE SCHALTKUPPLUNGEN 14 daNm PLV

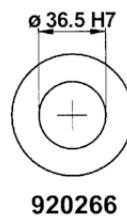
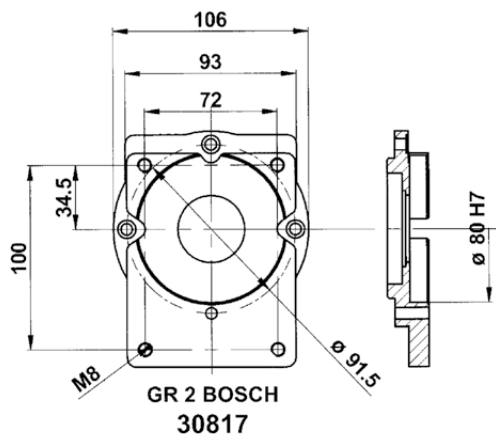
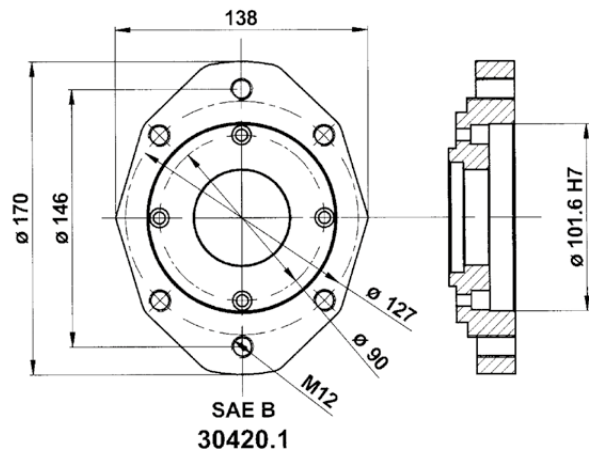
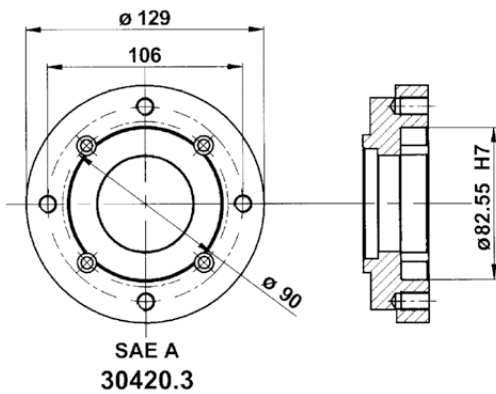
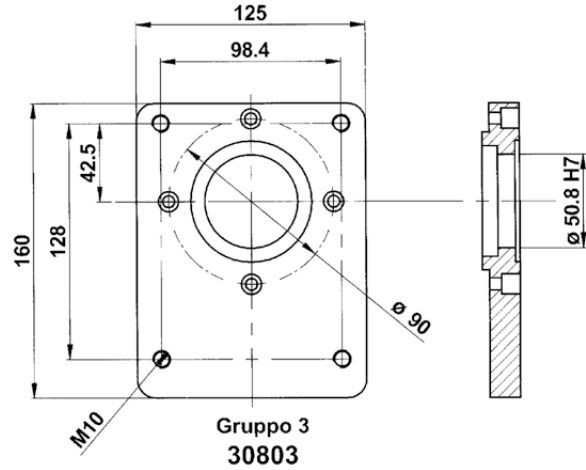
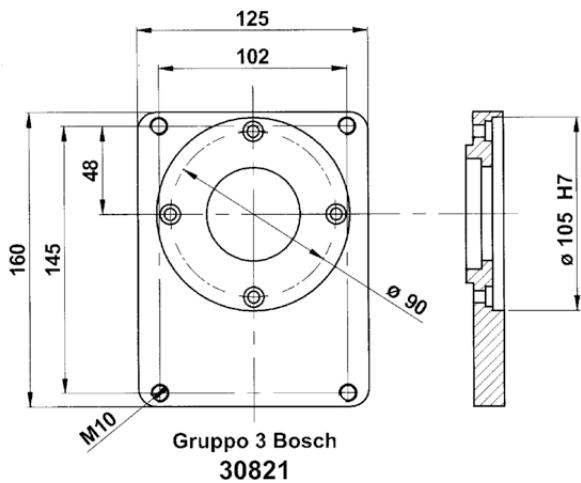

CODICE, CODE, CODE No., CODENUMMER					
Electric absorption	FLANGIA: TIPO, BRIDE: TYPE, FLANGE: TYPE, FLANSCHTYPE				
	Gr.2 BOSCH	Gr.3	Gr. 3 BOSCH	SAE A	SAE B
12 Volt	30929-1/2B	30931-1	30931-1/3B	30929-1/SA	30929-1/SB
24 Volt	30930-1/2B	30932-1	30932-1/3B	30930-1/SA	30930-1/SB







**OLEODINAMICA BORELLI**  
**HYDRAULIC COMPONENTS**

- TAVOLA RICAMBI INNESTO ELETTROMAGNETICO 21daNm
- TABLEAU DES PIECES DETACHEES POUR EMBRAYAGE ELECTROMAGNETIQUE 21daNm
- SPARE PARTS TABLE FOR ELECTROMAGNETIC COUPLING 21daNm
- ERSATZTEILLISTE FUR ELEKTROMAGNETISCHE SCHALKUPPLUNGEN 21daNm

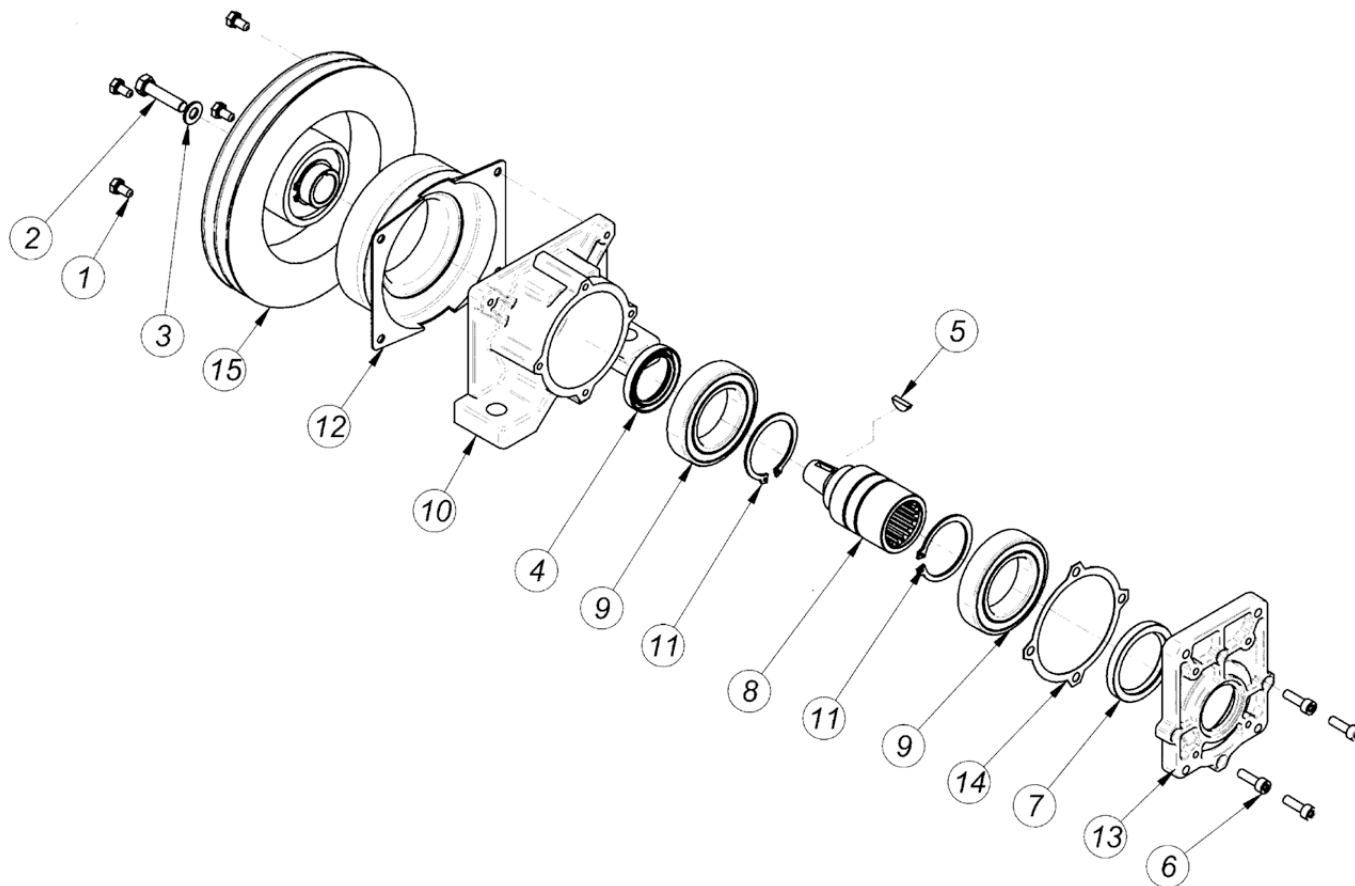

Pos.	CODICE	DENOMINAZIONE	DENOMINATION	DESCRIPTION	BEZEICHNUNG	Q.TA'
1	611428	Vite EN 24017 M6x12	Vis EN24017 M6x12	Soket EN 24017 M6x12	Befestigungsschraube EN 24017 M6x12	4
2	610516	Vite EN 24017 M8x35	Vis EN 24017 M8x35	Socket EN 24017 M8x35	Befestigungsschraube EN 24017 M8x35	1
3	RSPAL8	Rosetta per M8	Rondelle D.8	Washer d.8	Rosette durchm 8	1
4	303550	Anello di tenuta 35x50x7	Bague d'etancheite 35x50x7	Sealing ring 35x50x7	Dichtring 35x50x7	1
5	700465	Linguetta UNI 6606 4x6.5	Languette UNI 6606 4x6.5	Woodruff key UNI 6606 4x6.5	Halbrundkeil UNI 6606 4x6.5	1
6	610620	Vite T.C.E.I M6x20	Vis T.C.H.C. M6x20	Socket capscrew M6x20	Befestigungsschraube UNI 5931 M6x20	4
7	304560	Anello di tenuta 45x60x7	Bague d'etancheite 45x60x7	Sealing ring 45x60x7	Dichtring 45x60x7	1
8	A30901	Albero	Arbre	Shaft	Welle	1
9	506009/2Z	Cuscinetto 6009 2rs	Palier SKF 6009 2RS	Bearing SKF 6009 2RS	Kugellager SKF 6009-2RS	2
10	30009.1	Scatola	Carcasse	Housing	Gehäuse	1
11	904500	Anello elastico d.45	Circlip d.45	Snap ring d.45	Seegerring d.45	2
12	401221/186B 402421/186B	Bobina	Bobine	Coil	Zündspüle	1
13	30900.1	Flangia per pompe Gr 1 - 2	Flasque puor pompes Gr 1 - 2	Flange for pumps Gr 1 - 2	Flansch fur pompe Gr 1- 2	1
14	30009.1.1	Guarnizione	Joint	Gasket	Dichtung	1
15	4021/186BP	Elettrofrizione PLV	Electro-embayage PLV	Electric clutch PLV	Elektroschaltkplplung PLV	1



- **INNESTO ELETTRIMAGNETICO 21daNm**
- **EMBAYAGE ELECTROMAGNETIQUE 21daNm**
- **ELECTROMAGNETIC COUPLING 21daNm**
- **ELEKTROMAGNETISCHE SCHALKUPPLUNGEN 21daNm**

SERIE: 30990 12 Volt

SERIE: 30991 24 Volt

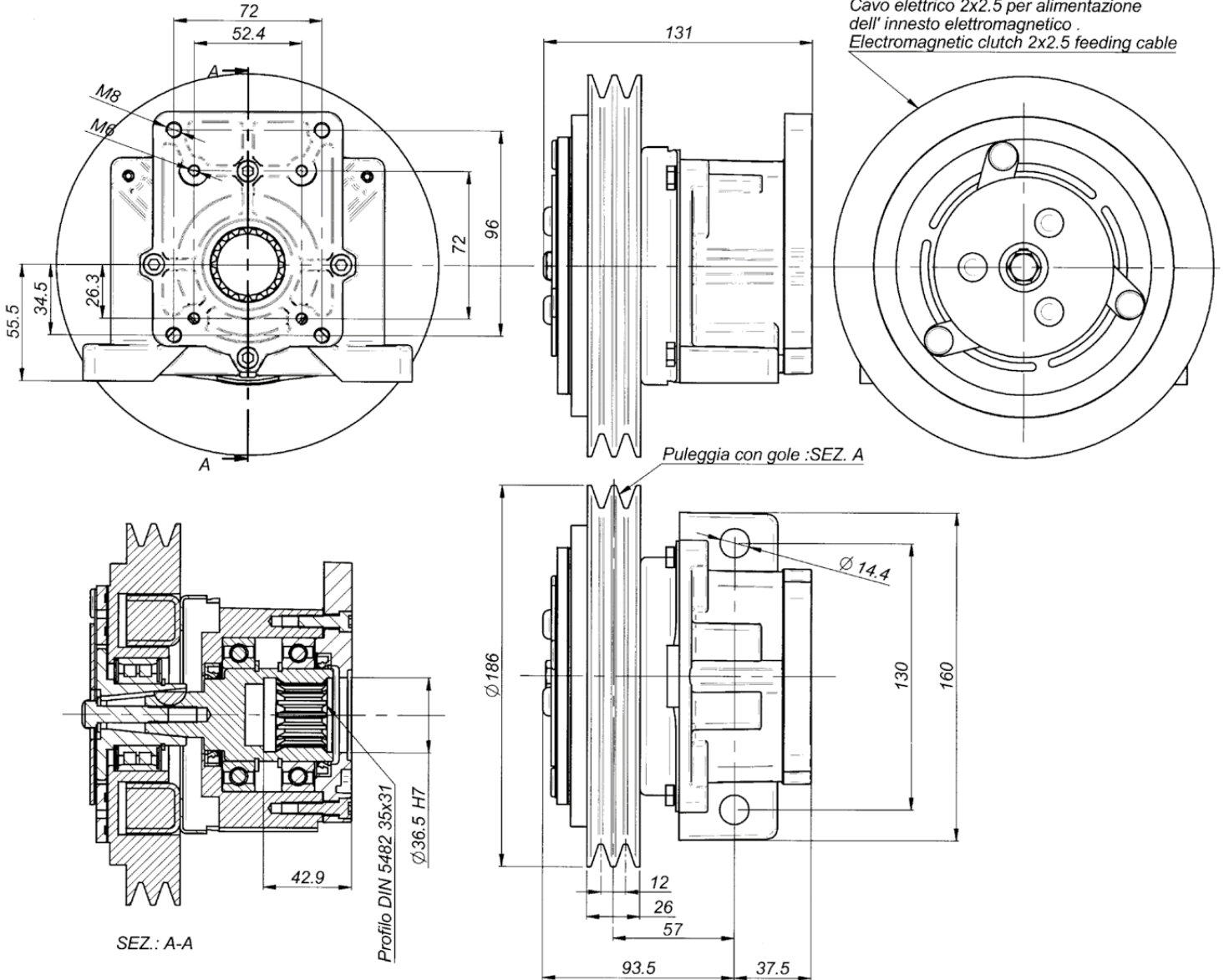

Nominal torque	16,0 daNm		Connection time		25 m/sec	
Static torque	21,0 daNm		Disconnection time		40 m/sec	
Dynamic torque	14,5 daNm	at 500 rpm	Minimum time between two connection		20 sec	
	12,0 daNm	at 1000 rpm				
	9,5 daNm	at 1500 rpm				
	8,8 daNm	at 2000 rpm	Max speed		5000 rpm	
	8,0 daNm	at 2500 rpm	Weight		8 Kg	
7,8 daNm	at 3000 rpm					
Electric absorption	Resistance (Ω)		Current (A)		Power (W)	
	20° C	120° C	20° C	120° C	20° C	120° C
12 V DC	2,96	3,97	4,05	2,71	48,70	32,50
24 V DC	12,30	16,60	1,95	1,31	47,00	30,70

All technical data are at 20°C / at 120 °C the performance are less 20%  
All electromegetic clutches are reversible.



- FLANGE PER INNESTI ELETTRIMAGNETICI 21 daNm
- BRIDE POUR EMBRAYAGES ELECTROMAGNETIQUE 21 daNm
- FLANGES FOR ELECTROMAGNETIC COUPLING 21 daNm
- FLANSCHEN FÜR ELEKTROMAGNETISCHE SCHALTKUPPLUNGEN 21 daNm

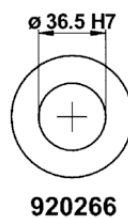
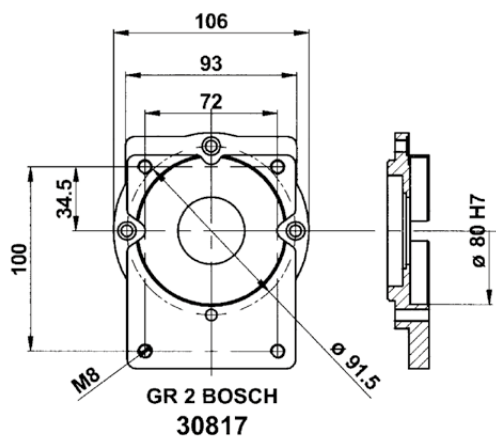
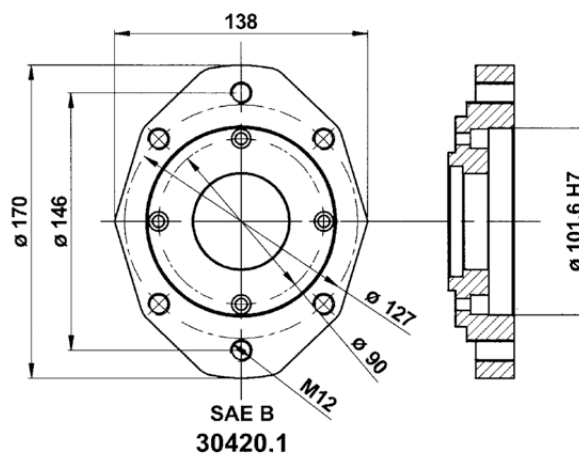
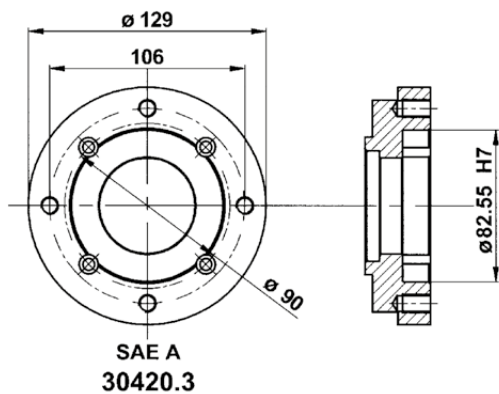
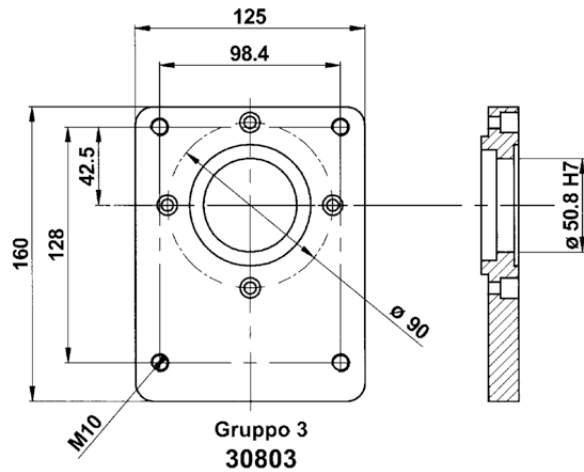
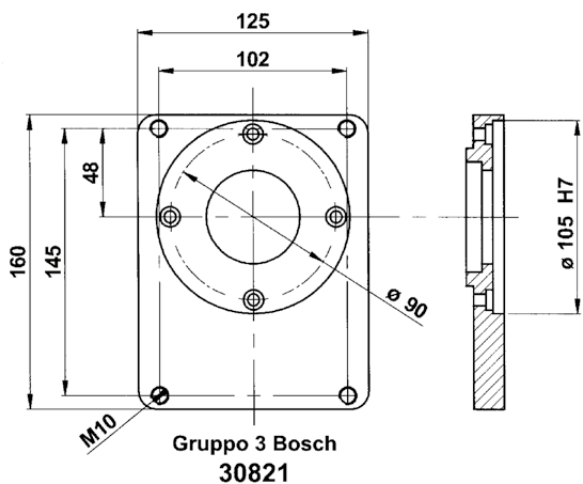

CODICE, CODE, CODE No., CODENUMMER					
Electric absorption	FLANGIA: TIPO, BRIDE: TYPE, FLANGE: TYPE, FLANSCHTYPE				
	Gr.2 BOSCH	Gr.3	Gr. 3 BOSCH	SAE A	SAE B
12 Volt	30990/2B	30992	30992/3B	30990/SA	30990/SB
24 Volt	30991/2B	30993	30993/3B	30991/SA	30991/SB





**OLEODINAMICA BORELLI**  
**HYDRAULIC COMPONENTS**

- TAVOLA RICAMBI INNESTO ELETTROMAGNETICO 50daNm
- TABLEAU DES PIECES DETACHEES POUR EMBRAYAGE ELECTROMAGNETIQUE 50daNm
- SPARE PARTS TABLE FOR ELECTROMAGNETIC COUPLING 50daNm
- ERSATZTEILLISTE FUR ELEKTROMAGNETISCHE SCHALKUPPLUNGEN 50daNm

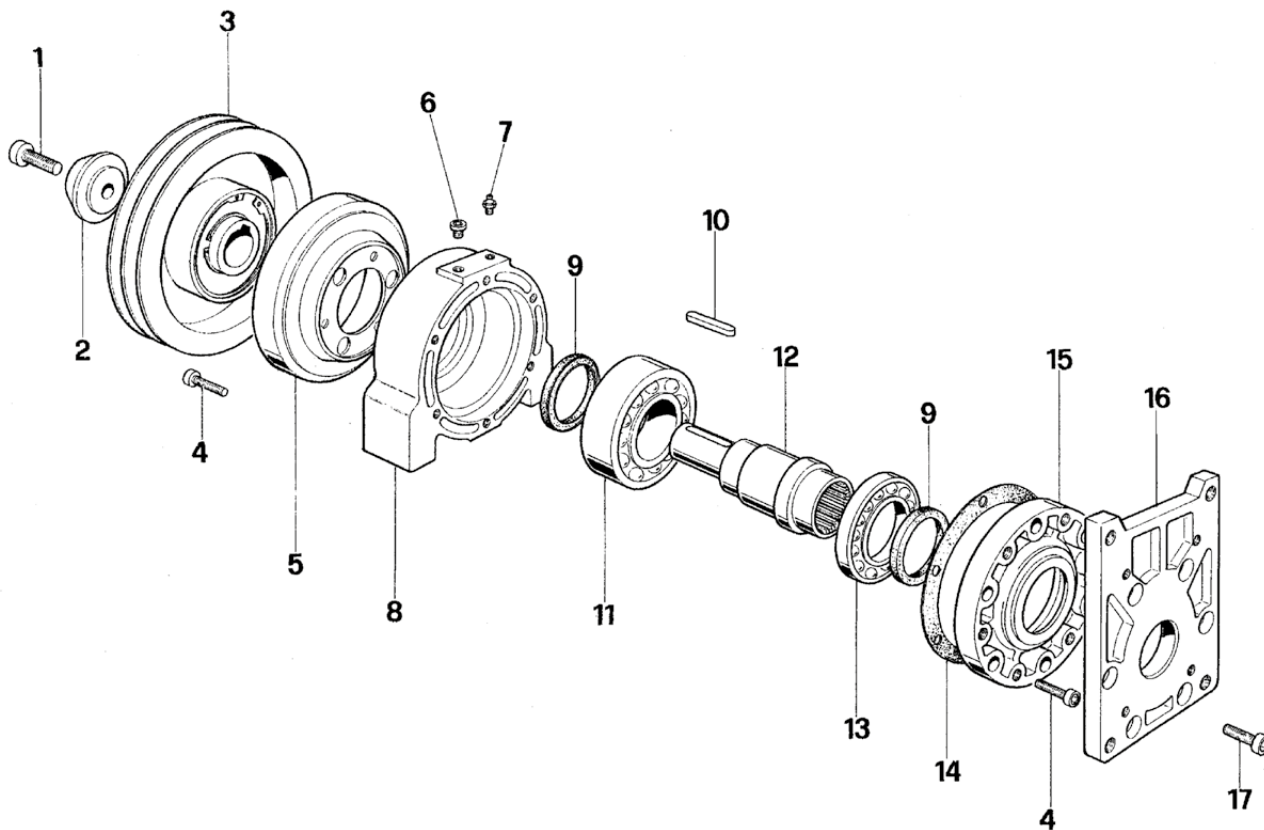

POS.	CODICE	DENOMINAZIONE	DENOMINATION	DESCRIPTION	BEZEICHNUNG	Q.TA'
1	611645	Vite T.C.E.I. M16x45	Vis T.C.H.C. M16x45	Socket capscrew M16x45	Befestigungsschraube UNI 5931 M16x45	1
2	RSP016	Rondella speciale D.16	Special rondelle d.16	Special washer d.16	Rosette d.16	1
3	4050/229BP	Elettrofrizione	Electro-embayage	Electric clutch	Elektroschaltkupplung	1
4	611020	Vite T.C.E.I. M10x20	Vis T.C.H.C. M10x20	Socket capscrew M10x20	Befestigungsschraube UNI 5931 M10x20	3
5	401250/229B 402450/229B	Bobina	Bobine	Coil	Zundspule	1
6	940182	Tappo scarico olio 1/8" G	Bouchon vindage huile 1/8"G	Oil drain plug 1/8"G	Olablabschraube 1/8"G	1
7	500000.1	Ingrassatore M8x1.25	Graisseur M8x1.25	Grease nipple M8x1.25	Fettbuchse M8x1.25	1
8	30009.30	Scatola	Carcasse	Housing	Gehuase	1
9	306075	Anello di tenuta 60x75x8	Bague d'etancheite 60x75x8	Sealing ring 60x75x8	Dichtring , durchm. 60x75x8	2
10	421086	Chiavetta 10x8x60 UNI 6604	Clavette 10x8x60 UNI 6604	Key 10x8x60 UNI 6604	Keil 10x8x60 UNI 6604	1
11	503212/Z	Cuscinetto 3212 A	Pallier 3212 A	Bearing 3212 A	Kugellager 3212 A	1
12	Ac30940	Albero	Arbre	Shaft	Welle	1
13	501601/Z	Cuscinetto 16012 A	Pallier 16012 A	Bearing 16012 A	Kugellager 16012 A	1
14	30470.2	Guarnizione	Joint	Gasket	Dichtung	1
15	30470	Flangia circolare	Bride circulaire	Round flange	Runder flansch	1
16	30900.1	Flangia pompa	Bride	Flange	Flansch	1
17	611025	Vite T.C.E.I. M10x25	Vis T.C.H.C. M10x25	Socket capscrew M10x25	Befestigungsschraube UNI 5931 M10x25	6



- **INNESTO ELETTROMAGNETICO 50daNm**
- *EMBAYAGE ELECTROMAGNETIQUE 50daNm*
- *ELECTROMAGNETIC COUPLING 50daNm*
- *ELEKTROMAGNETISCHE SCHALTKUPPLUNGEN 50daNm*

SERIE: 30940/SF 12 Volt

SERIE: 30941/SF 24 Volt

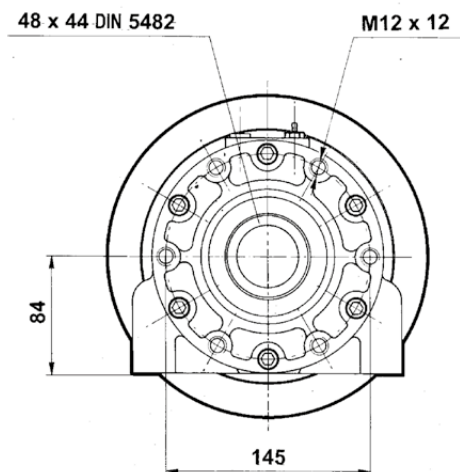
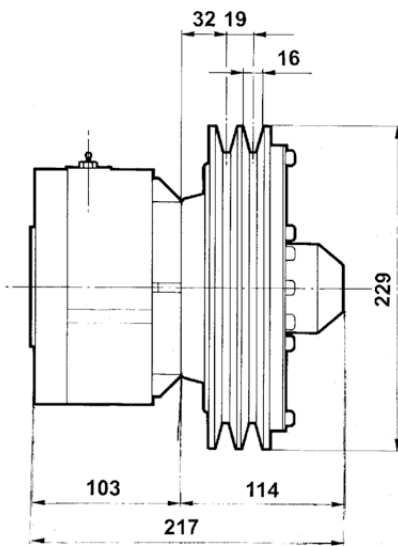
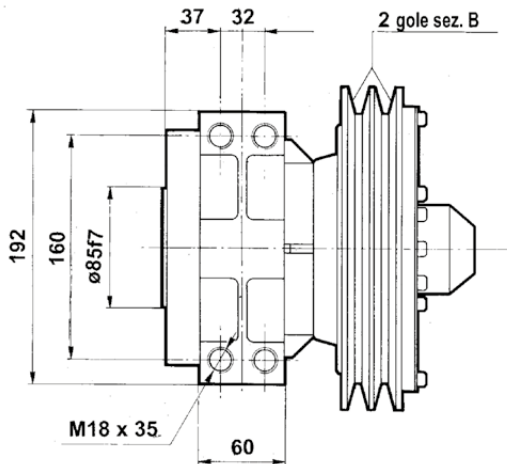

Nominal torque	38,0 daNm		Connection time		25 m/sec	
Static torque	50,0 daNm		Disconnection time		40 m/sec	
Dynamic torque	33,0 daNm	at 500 rpm	Minimum time between two connection		20 sec	
	31,5 daNm	at 1000 rpm				
	28,7 daNm	at 1500 rpm				
	28,0 daNm	at 2000 rpm	Max speed		5000 rpm	
	27,2 daNm	at 2500 rpm	Weight		20 Kg	
27,0 daNm	at 3000 rpm					
Electric absorption	Resistance (Ω)		Current (A)		Power (W)	
	20° C	120° C	20° C	120° C	20° C	120° C
12 V DC	1,81	2,60	6,60	4,62	80,00	56,00
24 V DC	7,40	10,50	3,25	2,30	78,00	54,60

All technical data are at 20°C / at 120 °C the performance are less 20%  
All electromagneteic clutches are reversible.



- FLANGE PER INNESTI ELETTROMAGNETICI 50 daNm
- BRIDE POUR EMBRAYAGES ELECTROMAGNETIQUE 50 daNm
- FLANGES FOR ELECTROMAGNETIC COUPLING 50 daNm
- FLANSCHEN FÜR ELEKTROMAGNETISCHE SCHALT Kupplungen 50 daNm

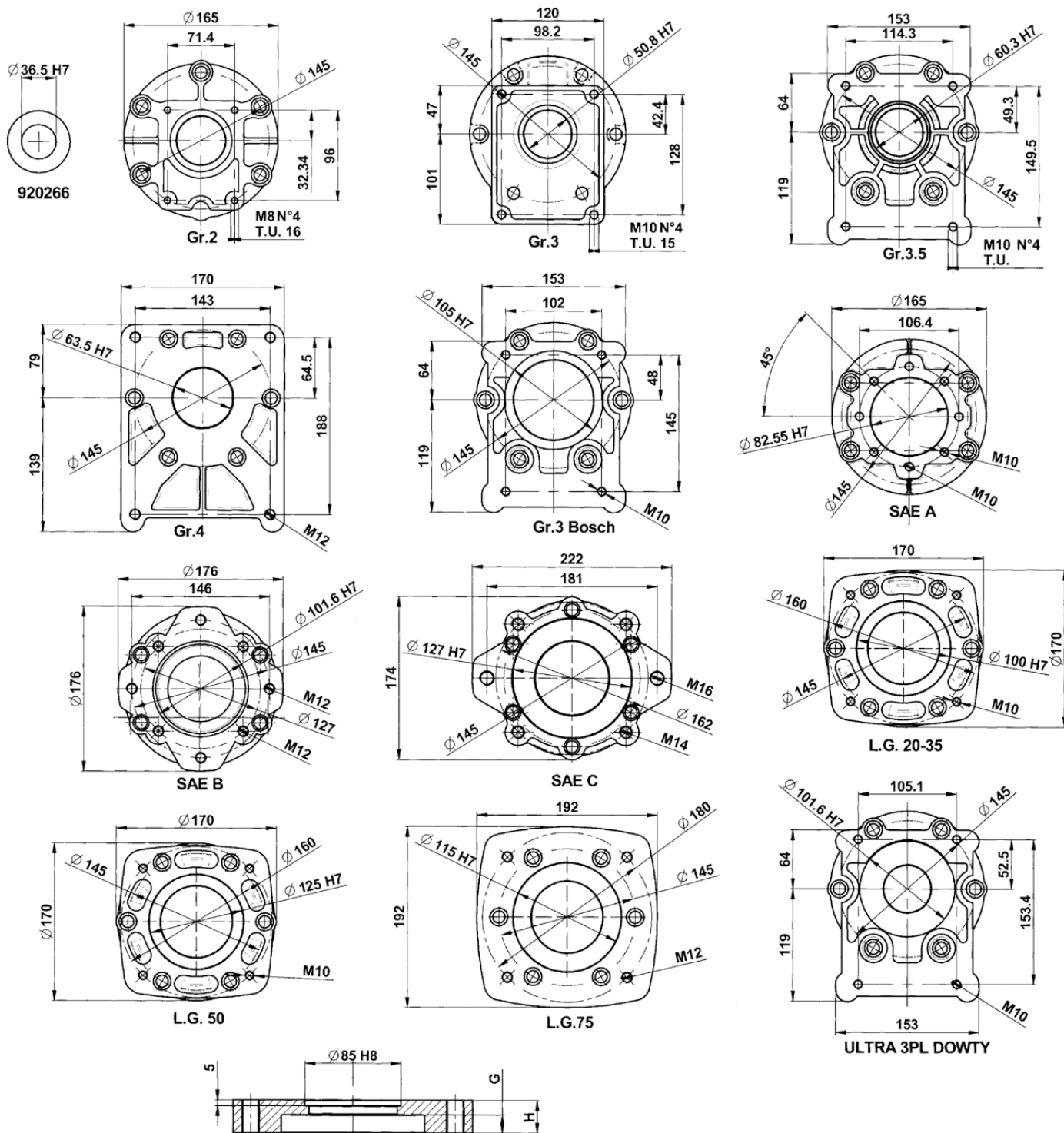

Flangia : Tipo Bride : Type Flange : Type Flanschttype	Gr.2	Gr.3	Gr.3.5	Gr.4	Gr.3 BOSCH	SAE A	SAE B	SAE C	L.G. 20-35	L.G. 50	L.G.75	ULTRA 3PL DOWTY
H	21	23	24	23	19	25	25	28	34	41	41	24.5
G	17	21	11.5	16	12	21	12	16	25	32.5	33	10.5
Codice flangia Code bride Code N. flange Codenummer flanschttype	30400	30401	30402	30403	30417	30420	30422	30432	30461	30462	30463	30471







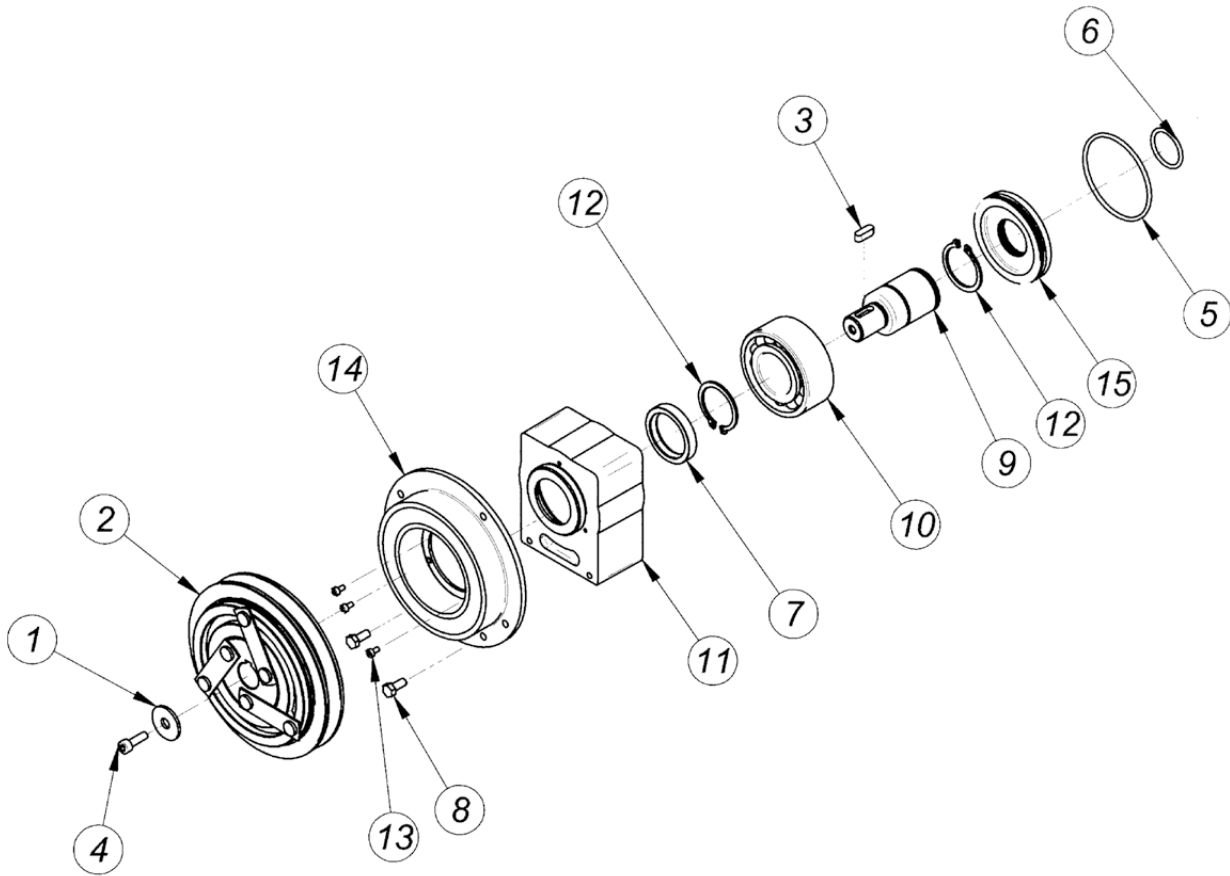

Pos.	CODICE	DENOMINAZIONE	DENOMINATION	DESCRIPTION	BEZEICHNUNG	Q.TA'
1	RSP246	Rosetta UNI 6593 - 6x24x2	Rondelle UNI 6593 - 6x24x2	Washer UNI 6593 - 6x24x2	Rosette UNI 6593 - 6x24x2	1
2	4003/125BP	Puleggia elettrofrizione	Poulie embrayage électrique	Electric clutch pulley	Elektroschaltkupplungsscheibe	1
3	435515	Linguetta UNI 6604 A 5x5x20	Langnette UNI 6604 5x5x20	Woudruff key UNI 6604 5x5x20	Halbrundkeil UNI 6604 5x5x20	1
4	610620	VTCEI UNI 5931 M6x12	Vis TCHC UNI 5931 M6x12	Socket capscrew UNI 5931 M6x12	Befestigungsschraube UNI 5931 M6x12	1
5	403225	Anello OR D.60	Bague torique d.60	O-Ring d.60	O-Ring d.60	1
6	402100	Anello OR	Bague torique	O-Ring	O-Ring	1
7	303040	Anello di tenuta 30x40x7	Bague d'etancheite 30x40x7	Sealing ring 30x40x7	Dichtring 30x40x7	1
8	620512	Vite EN 24017 M5x12	Vis EN 24017 M5x12	Socket EN 24017 M5x12	Befestigungsschraube EN 24017 M5x12	2
9	AC30900	Albero	Arbre	Shaft	Welle	1
10	503206	Cuscinetto SKF 3206	Palier SKF 3206	Bearing SKF 3206	Kugellager SKF 3206	1
11	30009-3/V	Scatola	Carcasse	Housing	Gehäuse	1
12	903000	Anello elastico UNI 7436 - 25	Circlip UNI 7436 - 25	Snap ring UNI 7436 - 25	Seegerring UNI 7436 - 25	2
13	610306	VITE UNI 5931 M3x6	Vis T.C.H.C M3x6 UNI 5931	Socket capscrew M3x6 UNI 5931	Zylinderkopfschraube mit innensechskant M3x6 UNI 5931	3
14	401203/125B 402403/125B	Bobina	Bobine	Coil	Zundspüle	1
15	COP-062	Anello	Bague	Ring	Ring	1



- **INNESTO ELETTROMAGNETICO 3 daNm**
- **EMBRAYAGE ELECTROMAGNETIQUE 3 daNm**
- **ELECTROMAGNETIC COUPLING 3 daNm**
- **ELEKTROMAGNETISCHE SCHALTKUPPLUNGEN 3 daNm**

SERIE: °30900-1 12 Volt  
SERIE: °30900-2 24 Volt

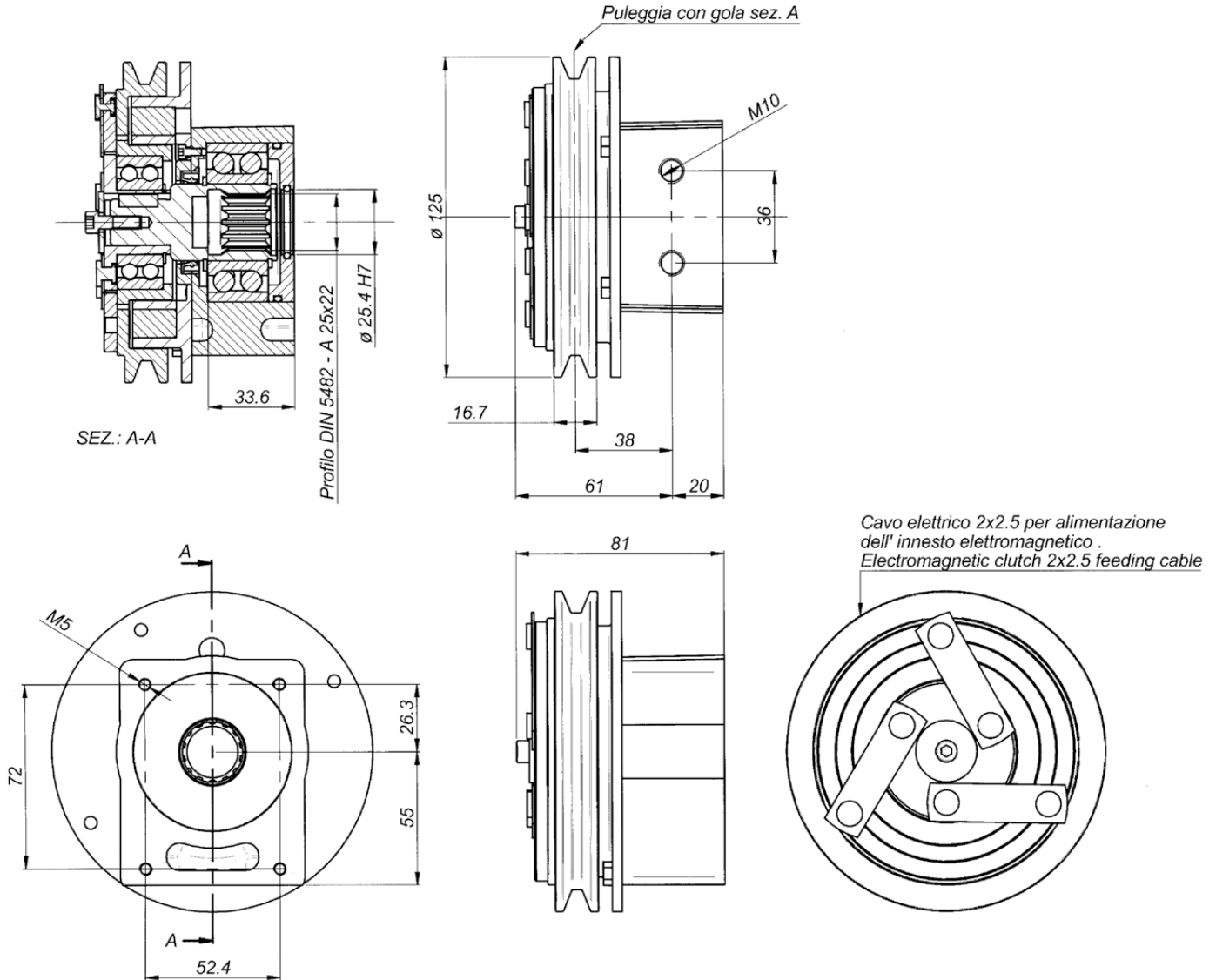

Nominal torque	3,0 daNm		Connection time	25 m/sec		
Static torque	4,5 daNm		Disconnection time	40 m/sec		
Dynamic torque	3,2 daNm	at 500 rpm	Minimum time between two connection	20 sec		
	2,8 daNm	at 1000 rpm				
	1,7 daNm	at 1500 rpm				
	1,4 daNm	at 2000 rpm	Max speed	5000 rpm		
	1,2 daNm	at 2500 rpm	Weight	3 Kg		
0,9 daNm	at 3000 rpm					
Electric absorption	Resistance ( W )		Current ( A )		Power ( W )	
	20° C	120° C	20° C	120° C	20° C	120° C
12 V DC	5,7	7,9	2,1	1,6	25,2	18
24 V DC	21,7	30,7	1,1	0,8	26,5	19

All technical data are at 20°C / at 120° C the performance are less 20%  
All electromagneteic clutches are reversible.



## I nostri cataloghi



## DOVE SIAMO



OLEODINAMICA **BORELLI**  
HYDRAULIC COMPONENTS

**OLEODINAMICA BORELLI**  
di Borelli Claudio

VIA GALVANI, 2 • 42011 BAGNOLO IN PIANO (RE)  
TEL. +39.0522.951628-952080 • FAX +39.0522.951238  
[www.oleodinamicaborelli.it](http://www.oleodinamicaborelli.it) • [info@oleodinamicaborelli.it](mailto:info@oleodinamicaborelli.it)



## LubeTeam Hydraulic S.r.l.

*Administration and Headquarter:*

Via Tufara Scautieri, 6

83018 - San Martino Valle Caudina (AV)

*Office and Warehouse:*

S.S. 7 Appia, Km. 237,00

82011 - Airola BN

ITALY

Tel. +39 0823 950 994

Fax +39 0823 412 546

[www.lubeteam.it](http://www.lubeteam.it) [info@lubeteam.it](mailto:info@lubeteam.it)

Italian VAT / C.F. e P.IVA: 01251720627

Follow us



This document is the property of LubeTeam Hydraulic S.r.l. All data reported here are for the exclusive use of the Receiver. Reproduction is not authorized without writing permission, in all or in part of the content of this document, in accordance to Law 633 art. 171, dated April 22, 1941.

Il presente documento è di proprietà della LubeTeam Hydraulic S.r.l. I dati riportati sono per esclusivo del destinatario. La riproduzione, di tutto o in parte, non è autorizzata senza permesso scritto secondo l'art. 171 della L. 633 del 22 Aprile 1941.