

High pressure ball valves

Hydraulic and Oil&Gas

2- 3 - 4 Way



 HYDRAULIC
COMPONENTS
& FLUID CONTAMINATION
CONTROL













All trademarks belong to their respective owners; third party trademarks, product names, trade names, corporate names and company names mentioned may be trademarks of their respective owners or registered trademarks of other companies and are used for instructional purposes and for the benefit of the owner, without any end of Copyright infringement in force.





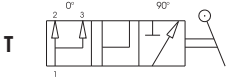

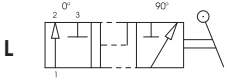
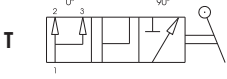

Tutti i marchi riportati appartengono ai legittimi proprietari; marchi di terzi, nomi di prodotti, nomi commerciali, nomi corporativi e società citati possono essere di proprietà dei rispettivi titolari o registrati da altre società e sono stati utilizzati a puro scopo esplicativo e a beneficio del possessore, senza alcun fine di violazione dei diritti di Copyright vigenti.

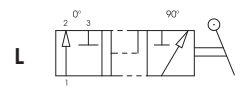
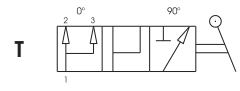

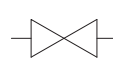
SPECIALIST IN BALL VALVES

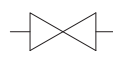

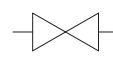

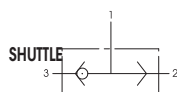



TYPE	DIAGRAM	APPLICATIONS	P.max (Mpa)	CONNECTIONS	DN	MATERIAL	
GEM - pag 29	2-way	Construction Agriculture Hydraulics Paint	50	BSP-NPT-SAE-DIN 1/4	DN6	CS/SS	
							
GE1 - pag 33	2-way	Construction Agriculture Hydraulics Paint Bio gas	50	BSP-NPT-SAE-DIN 1/4	DN6	CS	
			50	3/8	DN10		
			50	1/2	DN13		
GE2 - pag 37	2-way	Construction Agriculture Hydraulics Paint Bio gas	50	BSP-NPT-SAE-DIN 1/8	DN4	CS/SS	
			50	1/4	DN6		
			50	3/8	DN10		
			50	1/2	DN13		
			40	3/4	DN20		
			35	1	DN25		
			35	1 1/4 R	DN25		
			35	1 1/2 R	DN25		
GE3 - pag 45	3-way	Construction Agriculture Hydraulics Paint Bio gas	50	BSP-NPT-SAE-DIN 1/8	DN4	CS/SS	
			50	1/4	DN6		
			50	3/8	DN10		
			50	1/2	DN13		
			35/40	3/4	DN20		
			35	1	DN25		
			35	1 1/4 R	DN25		
			35	1 1/2 R	DN25		
GE5 - pag 53	3-way	Construction Agriculture Hydraulics Paint Bio gas	50	BSP-NPT-SAE-DIN 1/4	DN6	CS	
			50	3/8	DN10		
			50	1/2	DN13		

"The company reserves the right to operate dimensional changes without prior notice".

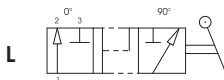
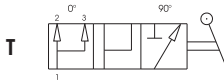
TYPE	DIAGRAM	APPLICATIONS	P.max (Mpa)	CONNECTIONS	DN	MATERIAL
GE3K - pag 57	3-way	Construction Agriculture Hydraulics Paint Bio gas		BSP-NPT-SAE-DIN		CS/SS
			50	1/8	DN4	
			50	1/4	DN6	
			50	3/8	DN10	
			50	1/2	DN13	
			35/40	3/4	DN20	
			35	1	DN25	
			35	1 1/4 R	DN25	
		35	1 1/2 R	DN25		
GEF - pag 61	2-way	Construction Agriculture Hydraulics Paint		ISO6162-1		CS/SS
			21 / 42	1/2	DN13	
			21 / 35	3/4	DN20	
			21 / 35	1	DN25	
GES - pag 65	2-way	Construction Agriculture Hydraulics Paint Mining		SAE J518		CS/SS
			21 / 42	1/2	DN13	
			21 / 35	3/4	DN20	
			21 / 35	1	DN25	
GEC - pag 69	2-way	Construction Agriculture Hydraulics Paint		SAE J1467		CS
			50	1/4	DN6	
			50	3/8	DN10	
			50	1/2	DN13	
			40	3/4	DN20	
		35	1	DN25		
GEV - pag 73	2-way	Construction Agriculture Hydraulics Paint		BSP-NPT-SAE-DIN		CS
			25	1/4	DN6	
			25	3/8	DN10	
			25	1/2	DN13	
			25	3/4	DN20	
		25	1	DN25		



SPECIALIST IN BALL VALVES

TYPE	DIAGRAM	APPLICATIONS	P.max (Mpa)	CONNECTIONS	DN	MATERIAL
GB2 - pag 79	2-way	Construction Agriculture Hydraulics Paint Bio gas		BSP-NPT-SAE-DIN		CS/SS
			35	1 1/4	DN32	
			35	1 1/2	DN40	
			35	2R	DN40	
			35	2	DN50	
GB3 - pag 85	3-way	Construction Agriculture Hydraulics Paint Bio gas		SAE J518		CS/SS
	 		35	1 1/4	DN32	
			35	1 1/2	DN40	
			35	2	DN50	
GBF - pag 89	2-way	Construction Agriculture Hydraulics Paint		ISO6162-1		CS/SS
			21 / 35	1 1/4	DN32	
			21 / 35	1 1/2	DN40	
			21 / 35	2	DN50	
GBS - pag 93	2-way	Construction Agriculture Hydraulics Paint		SAE J518		CS/SS
			21 / 35	1 1/4	DN32	
			21 / 35	1 1/2	DN40	
			21 / 35	2	DN50	
GBC - pag 97	2-way	Construction Agriculture Hydraulics Paint Mining		SAE J1467		CS
			35	1 1/4	DN32	
			35	1 1/2	DN40	
			35	2	DN50	







"The company reserves the right to operate dimensional changes without prior notice".

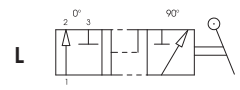
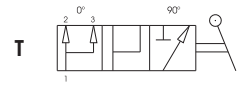

SPECIALIST IN BALL VALVES

TYPE	DIAGRAM	APPLICATIONS	P.max (Mpa)	CONNECTIONS	DN	MATERIAL
G4K - pag 119	4-way			BSP-NPT-SAE-DIN		
	G4 K13	Construction Agriculture Hydraulics Paint	50	1/4	DN6	CS
	G4 K14		50	3/8	DN10	
	G4 K15		40	1/2	DN13	
	G4 K16		35	3/4	DN20	
	G4 K17		35	1	DN25	
	G4 K18		35	1 1/4 R	DN25	
	G4 K19		35	1 1/2 R	DN25	
	G4 K20					
	G4 K21					
	G4 K22					
	G4 K23					
	G4 K24					
	G4 K25					
	G4 K26					
	G4 K27					



TYPE	DIAGRAM	APPLICATIONS	P.max (Mpa)	CONNECTIONS	DN	MATERIAL	
GPK2 - pag 125	2-way	Construction Agriculture Hydraulics Paint		BSP-NPT-SAE-DIN		CS	
				50	1/4		DN6
				50	3/8		DN10
				50	1/2		DN13
				40	3/4		DN20
				35	1		DN25
				35	1 1/4		DN32
		35	1 1/2	DN40			
35	2	DN50					
GPK3 - pag 129	3-way	Construction Agriculture Hydraulics Paint		BSP-NPT-SAE-DIN		CS	
	 			50	1/4		DN6
				50	3/8		DN10
				40	1/2		DN13
				35	3/4		DN20
				35	1		DN25
				35	1 1/4		DN32
		35	1 1/2	DN40			
35	2	DN50					
GRC - pag 135	2-way	Construction Agriculture Hydraulics Paint		ISO6162-1		CS/SS	
				25/35/40	1		DN25
				25/35/40	1 1/4		DN32
				25/35/40	1 1/2		DN40
				25/35/40	2		DN50
				25/35/40	2 1/2		DN65
				25/35/40	3		DN80
				25/35/40	4		DN100
		25/35/40	5	DN125			
GRS - pag 139	2-way	Construction Agriculture Hydraulics Paint		ISO6164		CS/SS	
				21/42	1/2		DN13
				21/42	3/4		DN20
				21/42	1		DN25
				21/42	1 1/4		DN32
				21/42	1 1/2		DN40
				21/42	2		DN50
				42	2 1/2		DN65
				42	3		DN80
				42	4		DN100
		42	5	DN125			







SPECIALIST IN BALL VALVES

TYPE	DIAGRAM	APPLICATIONS	P.max (Mpa)	CONNECTIONS	DN	MATERIAL
GHP - pag 145	2-way	Construction Agriculture Hydraulics Paint	37	BSP-NPT-SAE-DIN		CS/SS
				$\frac{1}{2}$	DN13	
				$\frac{3}{4}$	DN20	
				1	DN25	
				1 $\frac{1}{4}$	DN32	
				1 $\frac{1}{2}$	DN40	
				2	DN50	
				2 $\frac{1}{2}$	DN65	
				3	DN80	
		4	DN100			
GPS - pag 149	2-way	Construction Agriculture Hydraulics Paint	40	BSP-NPT-SAE-DIN		CS
				$\frac{1}{4}$	DN6	
				$\frac{3}{8}$	DN10	
				$\frac{1}{2}$	DN13	
				$\frac{3}{4}$	DN20	
		1	DN25			
RF - pag 153	2-way	Construction Agriculture Hydraulics Paint	35	BSP-NPT-SAE		CS
				$\frac{1}{4}$	DN6	
				$\frac{3}{8}$	DN10	
				$\frac{1}{2}$	DN13	
				$\frac{3}{4}$	DN20	
		1	DN25			
BD - pag 157	2-way	Construction Agriculture Hydraulics Paint	35	SAE J518		CS
				$\frac{1}{4}$	DN6	
				$\frac{3}{8}$	DN10	
				$\frac{1}{2}$	DN13	
				$\frac{3}{4}$	DN20	
		1	DN25			
VU - pag 161	2-way	Construction Agriculture Hydraulics Paint	50	BSP-NPT-SAE		CS/SS
				$\frac{1}{4}$	DN6	
				$\frac{3}{8}$	DN10	
				$\frac{1}{2}$	DN13	
				$\frac{3}{4}$	DN20	
				1	DN25	
				1 $\frac{1}{4}$	DN32	
				1 $\frac{1}{2}$	DN40	
		2	DN50			
VJBA - pag 165	2-way	Construction Agriculture Hydraulics Paint	35	BSP-NPT-SAE		CS
				$\frac{1}{4}$	DN6	
				$\frac{3}{8}$	DN10	
				$\frac{1}{2}$	DN13	
				$\frac{3}{4}$	DN20	
		1	DN25			

TYPE	DIAGRAM	APPLICATIONS	P.max (Mpa)	CONNECTIONS	DN	MATERIAL
GM1 - pag 171	2-way	Construction Petrochemistry		BSP-NPT-SAE-SW-BW		CS/SS
				1/4	DN6	
				3/8	DN10	
				1/2	DN13	
				3/4	DN20	
			1	DN25		
GM - pag 177	2-way	Construction Petrochemistry		BSP-NPT-SAE-SW-BW		CS/SS
			13,8-21-50	1/4	DN6	
			13,8-21-50	3/8	DN10	
			13,8-21-50	1/2	DN13	
			13,8-21-40	3/4	DN20	
			13,8-21-35	1	DN25	
			13,8-21-35	1 1/4	DN32	
			13,8-21-35	1 1/2	DN40	
			13,8-21-35	2	DN50	
			15	2 1/2	DN65	
		10	3	DN80		
5	4	DN100				
GN - pag 189	2-way	Construction Petrochemistry		BSP-NPT-SAE-SW-BW		CS/SS
			42-50	1/4	DN6	
			42-50	3/8	DN10	
			42-50	1/2	DN13	
			42-40	3/4	DN20	
			42-35	1	DN25	
			42-35	1 1/4	DN32	
			42-35	1 1/2	DN40	
		42-35	2	DN50		
SBF - pag 201	2-way	Construction Petrochemistry		ANSI B16.5		CS/SS
			2-5-10-15-25-42	1/2	DN13	
			2-5-10-15-25-42	3/4	DN20	
			2-5-10-15-25-42	1	DN25	
			2-5-10-15-25-42	1 1/4	DN32	
			2-5-10-15-25-42	1 1/2	DN40	
			2-5-10-15-25-42	2	DN50	
			2-5-10-15-25-42	2 1/2	DN65	
			2-5-10-15-25-42	3	DN80	
			2-5-10-15-25-42	4	DN100	
			2-5-10-15-25-42	5	DN125	
		2-5-10-15-25-42	6	DN150		



SPECIALIST IN BALL VALVES

TYPE	DIAGRAM	APPLICATIONS	P.max (Mpa)	CONNECTIONS	DN	MATERIAL
SBF - pag 201	2-way	Construction Petrochemistry	150 LBS UP TO 2500 LBS	ANSI B16.5		CS/SS
				RF	2 x 1 ¹ / ₂	
				RTS	2	
				BW	3 x 2	
				FF	3	
					4 x 3	
					4	
					6 x 4	
SBT - pag 215	2-way	Construction Petrochemistry	150 LBS UP TO 2500 LBS	ANSI B16.5		CS/SS
				RF	6	
				RTS	8 x 6	
				BW	8	
				FF	10 x 8	
					12 x 8	
					10	
					14 x 10	
					12	
					16 x 12	
					14	
					10 x 14	
					16	
					20 x 16	
					20	
					24 x 20	
					22	
					24	
					28 x 24	
			30 x 24			

ACCESSORIES

LOCKINGS KITS - pag 233



LKB FOR GM - GN
 LKF FOR GE - GB - GHP - GPK
 LKB FOR GR
 SECURITY BLOCK FOR GE - GB - GHP - GPK - G3/4K

HANDLES - pag 237



BENT HANDLES
 BUTTERFLY HANDLES
 CUT BENT HANDLES
 CUT STRAIGHT HANDLES
 PIPE HANDLES
 SHORT HANDLES
 STRAIGHT HANDLES

FLANGES - pag 241



CUT FLANGE
 UN-CUT FLANGE

LIMIT SWITCH - pag 245

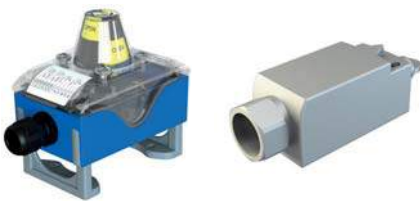

ACTUATED VALVES
 MANUAL VALVES

ACTUATORS - pag 253



ELECTRIC ACTUATORS
 DA ACTUATORS
 SR ACTUATORS
 PNEUMATIC ACTUATORS - TECHNICAL DETAILS

SEALS KITS - pag 279

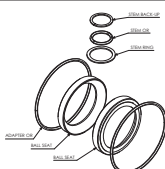

GB
 GE - GE1 - GE5 - GE3K
 GM - GN
 GPK
 GV

GE

GEM - GE1 - GE2 - GE3 - GE5
GE3K - GEF - GES - GEC - GEV



TECH
MATERIAL

KITS
LOCKING - HANDLES
FLANGE - LIMIT SWITCHES
ACTUATORS - SEALS KITS

OIL&GAS
GM1-GM - GN
SBF - SBT

OTHER
GHP - GPS - RF
BD - VU - VUJBA

GR
GRC - GRS

GPK
GPK2 - GPK3

G3K-4K
G3K - G4K

GV
GV2 - GV3

GB
GB2 - GB3 - GBF
GBS - GBC

GE
GEM - GE1 - GE2 - GE3
GE5 - GE3K - GEF
GES - GEC - GEV

+ GEM

2-WAY HIGH PRESSURE BALL VALVES



CARBON STEEL

- Type: ball valve GEM 2 way
- Body: round
- Material: 1,0737
- Ball seats: from DN4 up to DN6
- O-Rings: NBR, FKM, EPDM, MVQ
- Operating pressure: 500 Bar depending on valve size and seal materials selected
- Temp range: -20°C to +100°C depending on seal material selected

GEM	G 1/4		DN6		1	1	1	1	A	B		
Type and way of valve	GAS DIN/ISO 228 BSP	NPT ANSI/ASME B1.20.1	SAE J1926-1	DIN 2353 HEAVY SERIES	DIN 2353 LIGHT SERIES	Nominal dimension	Body material	Adapter material	Stem material	Ball material	Ball seat material	Adapter and stem seal material
GEM 2-way	G 1/4	N 1/4	SAE4	8S 10S	6L 8L	DN6	1 1,0737	1 1,0737	1 1,0737	1 1,0737	A POM D PEEK G PA612 K GEMPTFE C PTFE	B NBR E FKM F EPDM L MVQ

STAINLESS STEEL

- Type: ball valve GEM 2 way
- Body: round
- Material: 1,4305
- Ball seats: from DN4 up to DN6
- O-Rings: NBR, FKM, EPDM, MVQ
- Operating pressure: 500 Bar depending on valve size and seal materials selected
- Temp range: -30°C to +100°C different temperatures on request

GEM	G 1/4		DN6		3	3	3	3	A	B		
Type and way of valve	GAS DIN/ISO 228 BSP	NPT ANSI/ASME B1.20.1	SAE J1926-1	DIN 2353 HEAVY SERIES	DIN 2353 LIGHT SERIES	Nominal dimension	Body material	Adapter material	Stem material	Ball material	Ball seat material	Adapter and stem seal material
GEM 2-way	G 1/4	N 1/4	SAE4	8S 10S	6L 8L	DN6	3 1,4305	3 1,4305	3 1,4305	3 1,4305	A POM D PEEK G PA612 K GEMPTFE C PTFE	B NBR E FKM F EPDM L MVQ

"The company reserves the right to operate dimensional changes without prior notice".



GEM

2-WAY HIGH PRESSURE BALL VALVES

Specialist in Ball Valves

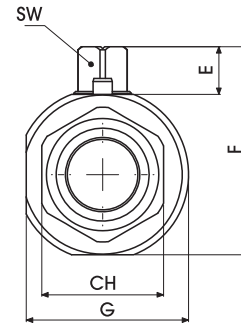
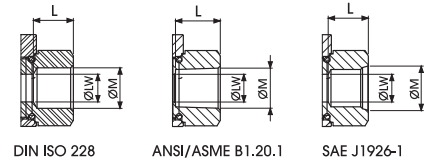
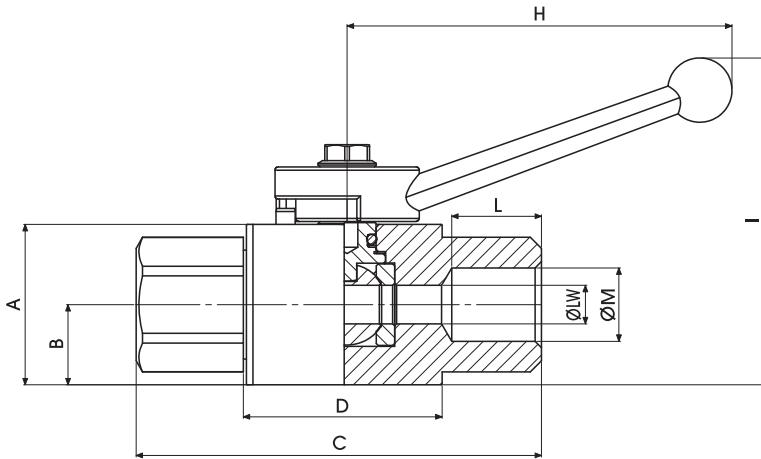

GEM DIN/ISO 228 BSP

Standard

																	CARBON STEEL	STAINLESS STEEL	
TYPE	PN	DN	A	B	C	D	E	F	G	H	I	L	ØM	CH	SW	ØLW	KG	ITEM CODE	ITEM CODE
GEM G 1/4	50 MPa	6	25	12,5	63	31,5	7	32,5	26,8	60	51	14	G 1/4	19	6	6	0,195	G12GGT15011A000	G12GGT15033A000

GEM ANSI/ASME B1.20.1 NPT

Standard

																	CARBON STEEL	STAINLESS STEEL	
TYPE	PN	DN	A	B	C	D	E	F	G	H	I	L	ØM	CH	SW	ØLW	KG	ITEM CODE	ITEM CODE
GEM N 1/4	50 MPa	6	25	12,5	63	31,5	7	32,5	26,8	60	51	14	N 1/4	19	6	6	0,195	G12NNT15011A000	G12NNT15033A000

GEM SAE J1926-1

Standard

																	CARBON STEEL	STAINLESS STEEL	
TYPE	PN	DN	A	B	C	D	E	F	G	H	I	L	ØM	CH	SW	ØLW	KG	ITEM CODE	ITEM CODE
GEM SAE4	50 MPa	6	25	12,5	63	31,5	7	32,5	26,8	60	51	14	7/16-20 UNF	19	6	6	0,195	G12EEE05011A000	G12EEE05033A000

+ GEM 2-WAY HIGH PRESSURE BALL VALVES

www.gemels.it

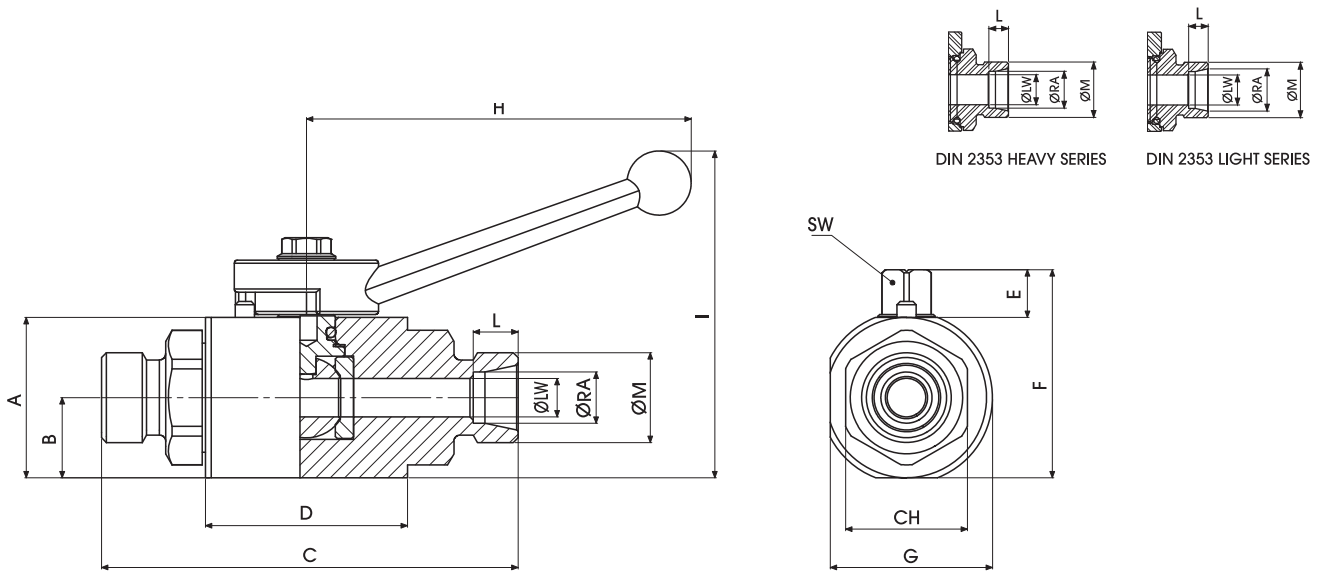

GEM DIN 2353 HEAVY SERIES

Standard

TYPE	PN	DN	A	B	C	D	E	F	G	H	I	L	ØM	CH	SW	ØLW	ØRA	KG	CARBON STEEL	STAINLESS STEEL
																			ITEM CODE	ITEM CODE
GEM 8S	50 MPa	6	25	12,5	65	31,5	7	32,5	26,8	60	51	7	16X1.5	19	6	6	8	0,195	G12DDS05011A000	G12DDS05033A000
GEM 10S	50 MPa	6	25	12,5	65	31,5	7	32,5	26,8	60	51	7	18X1.5	19	6	6	10	0,195	G12DDS15011A000	G12DDS15033A000

GEM DIN 2353 LIGHT SERIES

Standard

TYPE	PN	DN	A	B	C	D	E	F	G	H	I	L	ØM	CH	SW	ØLW	ØRA	KG	CARBON STEEL	STAINLESS STEEL
																			ITEM CODE	ITEM CODE
GEM 6L	50 MPa	6	25	12,5	65	31,5	7	32,5	26,8	60	51	7	M12X1.5	19	6	6	6	0,185	G12DDL05011A000	G12DDL05033A000
GEM 8L	50 MPa	6	25	12,5	65	31,5	7	32,5	26,8	60	51	7	M14X 1.5	19	6	6	8	0,185	G12DDL15011A000	G12DDL15033A000



GEM

2-WAY HIGH PRESSURE BALL VALVES

Specialist in Ball Valves

2016 - Edition 1

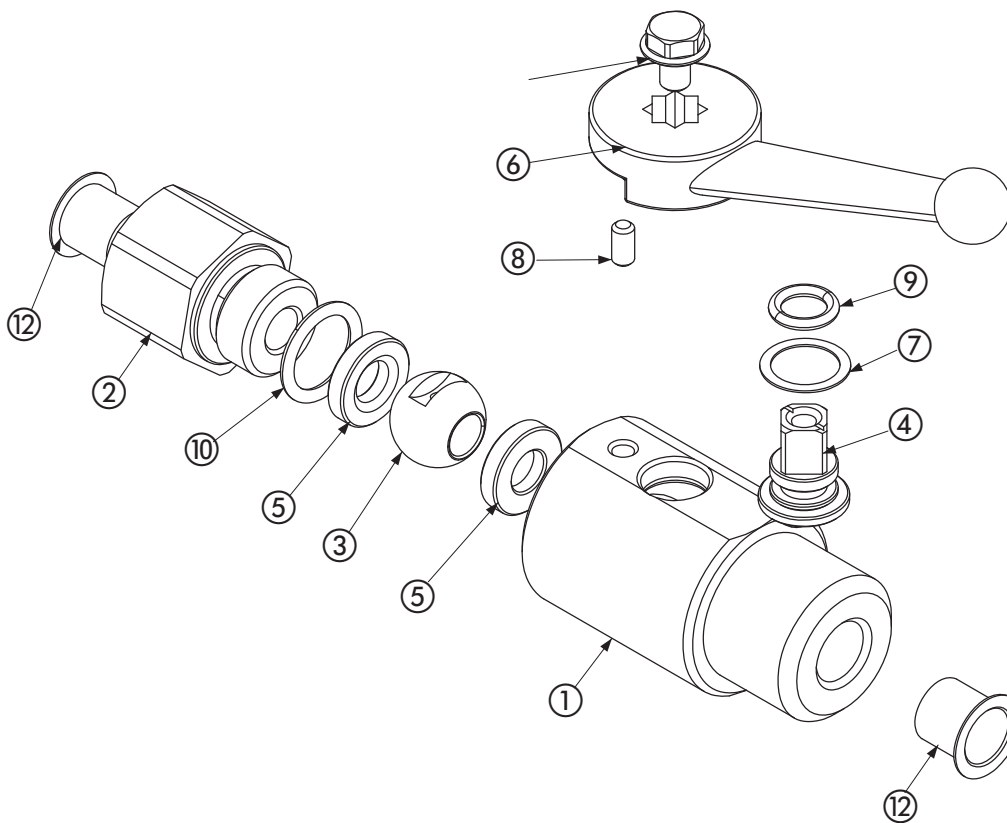

Carbon steel

Pos	Description	Material	Q.tà
1	Body	1,0737	1
2	Adapter	1,0737	1
3	Ball	1,0737	1
4	Stem	1,0737	1
5	Ball seat	POM	2
6	Handle	ZINC	1
7	Stem ring	POM	1
8	Spine	1,0737	1
9	Stem o-ring	NBR	1
10	Adapter o-ring	NBR	2
11	Screw	DIN 6921 8.8	1
12	Caps	PVC	2

On request

- Reduced bore
- O-Ring in FKM, EPDM, HNBR, KALREZ
- Seals in PTFE, PEEK, PA612, GEMPTFE, METAL TO METAL
- Special threads
- Stem in stainless steel 1,4404
- Ball in stainless steel 1,4404
- Pressure class up to PN50 Mpa
- Locking device

For further special requests please consult our technical/commercial service

Stainless steel

Pos	Description	Material	Q.tà
1	Body	1,4305	1
2	Adapter	1,4305	1
3	Ball	1,4404	1
4	Stem	1,4305	1
5	Ball seat	POM	2
6	Handle	ZINC	1
7	Stem ring	POM	1
8	Spine	1,4301	1
9	Stem o-ring	NBR	1
10	Adapter o-ring	NBR	2
11	Screw	DIN 6921 A2	1
12	Caps	PVC	2

On request

- Reduced bore
- O-Ring in FKM, EPDM, HNBR, KALREZ
- Seals in PTFE, PEEK, PA612, GEMPTFE, METAL TO METAL
- Special threads
- Pressure class up to PN50 Mpa
- Locking device

+ GE1

2-WAY HIGH PRESSURE BALL VALVES

SMALLER DESIGN

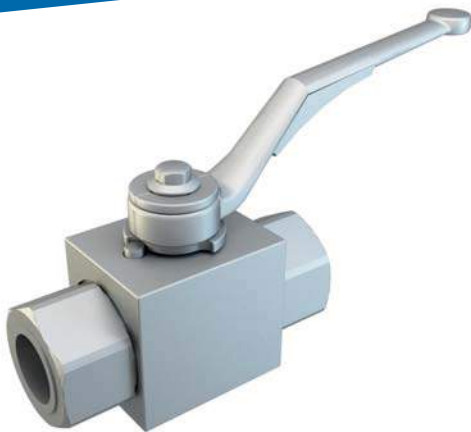

CARBON STEEL

- Type: ball valve GE 2 way 
- Body: block
- Material: 1,0737
- Ball seats: from DN6 up to DN13
- O-Rings: NBR, FKM, EPDM, MVQ
- Operating pressure: 500 Bar depending on valve size and seal materials selected
- Temp range: -20°C to +100°C depending on seal material selected

GE1	G 1/4			DN10	1	1	1	1	A	B
Type and way of valve	GAS	NPT	SAE	Nominal dimension	Body material	Adapter material	Stem material	Ball material	Ball seat material	Adapter and stem seal material
GE2 2-way	DIN/ISO 228 BSP	ANSI/ASME B1.20.1	J1926-1							
	G 1/4	N 1/4	SAE4	DN6	1 1,0737	1 1,0737	1 1,0737	1 1,0737	A POM	B NBR
	G 3/8	N 3/8	SAE6	DN10						
	G 1/2	N 1/2	SAE8	DN13						



2-WAY HIGH PRESSURE BALL VALVES

Specialist in Ball Valves

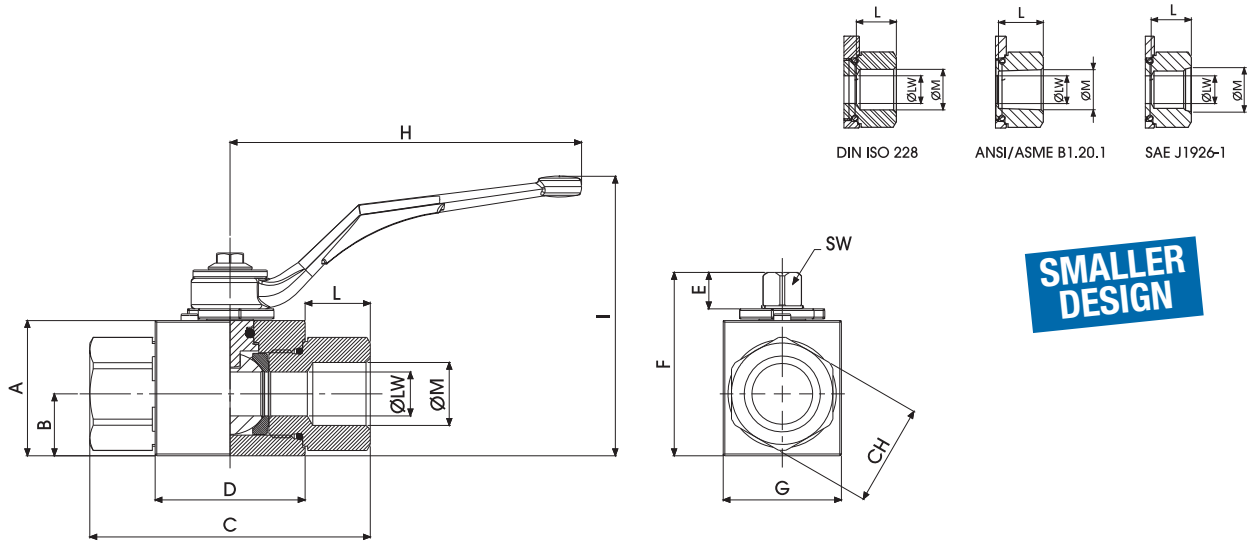

GE1 DIN/ISO 228 BSP

Standard

CARBON STEEL

TYPE	PN	DN	A	B	C	D	E	F	G	H	I	L	ØM	CH	SW	ØLW	KG	ITEM CODE
GE1 G 1/4	50 MPa	6	33	14,3	69	39,4	10,8	47,3	26	104	76	14,8	G 1/4	22	9	6	0,378	GE1GGT15011A000
GE1 G 3/8	50 MPa	10	35	15	71	41,8	10,8	49,3	30	104	78	14,6	G 3/8	27	9	10	0,467	GE1GGT25011A000
GE1 G 1/2	50 MPa	13	40	18,3	83	44,4	10,8	54,3	35	104	83	19,3	G 1/2	30	9	13	0,635	GE1GGT35011A000

GE1 ANSI/ASME B1.20.1 NPT

Standard

CARBON STEEL

TYPE	PN	DN	A	B	C	D	E	F	G	H	I	L	ØM	CH	SW	ØLW	KG	ITEM CODE
GE1 N 1/4	50 MPa	6	33	14,3	69	39,4	10,8	47,3	26	104	76	14,8	N 1/4	22	9	6	0,378	GE1NNT15011A000
GE1 N 3/8	50 MPa	10	35	15	71	41,8	10,8	49,3	30	104	78	14,6	N 3/8	27	9	10	0,467	GE1NNT25011A000
GE1 N 1/2	50 MPa	13	40	18,3	83	44,4	10,8	54,3	35	104	83	19,3	N 1/2	30	9	13	0,635	GE1NNT35011A000

GE1 SAE J1926-1

Standard

CARBON STEEL

TYPE	PN	DN	A	B	C	D	E	F	G	H	I	L	ØM	CH	SW	ØLW	KG	ITEM CODE
GE1 SAE4	50 MPa	6	33	14,3	69	39,4	10,8	47,3	26	104	76	15,5	7/16 UNF	22	9	6	0,378	GE1EEE05011A000
GE1 SAE6	50 MPa	10	35	15	71	41,8	10,8	49,3	30	104	78	16	9/16 UNF	27	9	10	0,467	GE1EEE15011A000
GE1 SAE8	50 MPa	13	40	18,3	83	44,4	10,8	54,3	35	104	83	17,5	3/4 UNF	30	9	13	0,623	GE1EEE25011A000

+ GE1

2-WAY HIGH PRESSURE BALL VALVES

www.gemels.it

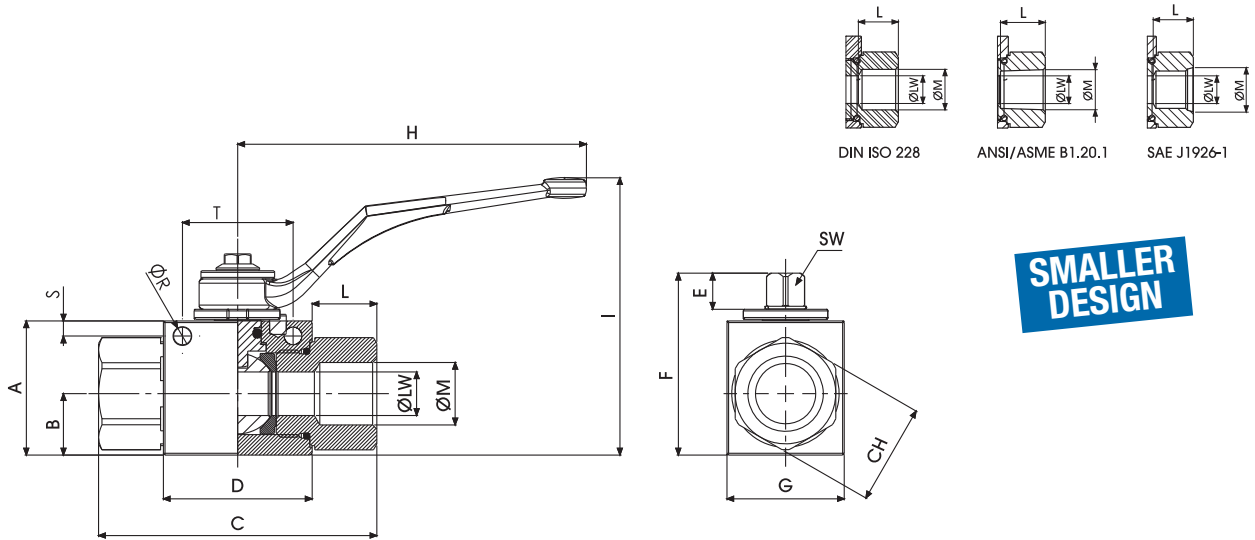

GE1 DIN/ISO 228 BSP

Fixing holes

CARBON STEEL

TYPE	PN	DN	A	B	C	D	E	F	G	H	I	L	ØM	CH	ØR	S	T	SW	ØLW	KG	ITEM CODE
GE1 G 1/4	50 MPa	6	33	14,3	69	39,4	10,8	47,3	26	104	76	14,8	G 1/4	22	5,25	4,5	33	9	6	0,378	GE1GGT15011AF10
GE1 G 3/8	50 MPa	10	35	15	71	41,8	10,8	49,3	30	104	78	14,6	G 3/8	27	5,25	4,5	33	9	10	0,467	GE1GGT25011AF10
GE1 G 1/2	50 MPa	13	40	18,3	83	44,4	10,8	54,3	35	104	83	19,3	G 1/2	30	5,25	4,5	33	9	13	0,635	GE1GGT35011AF10

GE1 ANSI/ASME B1.20.1 NPT

Fixing holes

CARBON STEEL

TYPE	PN	DN	A	B	C	D	E	F	G	H	I	L	ØM	CH	ØR	S	T	SW	ØLW	KG	ITEM CODE
GE1 N 1/4	50 MPa	6	33	14,3	69	39,4	10,8	47,3	26	104	76	14,8	N 1/4	22	5,25	4,5	33	9	6	0,378	GE1NNT15011AF10
GE1 N 3/8	50 MPa	10	35	15	71	41,8	10,8	49,3	30	104	78	14,6	N 3/8	27	5,25	4,5	33	9	10	0,467	GE1NNT25011AF10
GE1 N 1/2	50 MPa	13	40	18,3	83	44,4	10,8	54,3	35	104	83	19,3	N 1/2	30	5,25	4,5	33	9	13	0,635	GE1NNT35011AF10

GE1 SAE J1926-1

Fixing holes

CARBON STEEL

TYPE	PN	DN	A	B	C	D	E	F	G	H	I	L	ØM	CH	ØR	S	T	SW	ØLW	KG	ITEM CODE
GE1 SAE4	50 MPa	6	33	14,3	69	39,4	10,8	47,3	26	104	76	15,5	7/16 UNF	22	5,25	4,5	33	9	6	0,378	GE1EEE05011AF10
GE1 SAE6	50 MPa	10	35	15	71	41,8	10,8	49,3	30	104	78	16	9/16 UNF	27	5,25	4,5	33	9	10	0,467	GE1EEE15011AF10
GE1 SAE8	50 MPa	13	40	18,3	83	44,4	10,8	54,3	35	104	83	17,5	3/4 UNF	30	5,25	4,5	33	9	13	0,623	GE1EEE25011AF10

SMALLER DESIGN

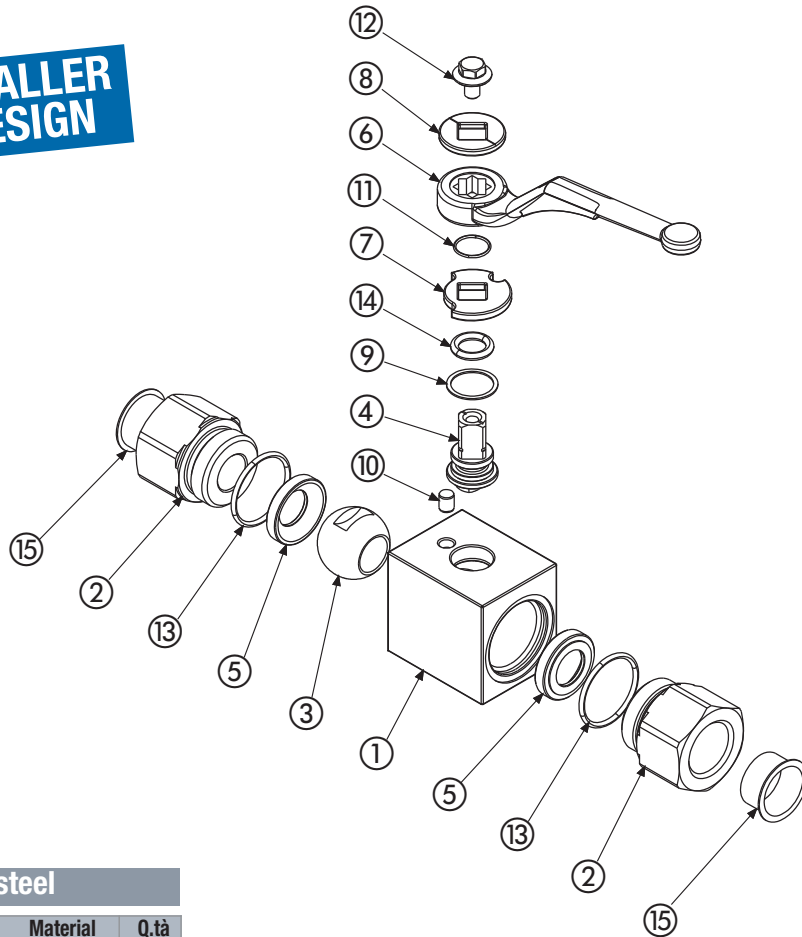

Carbon steel

Pos	Description	Material	Q.tà
1	Body	1,0737	1
2	Adapter	1,0737	2
3	Ball	1,0737	1
4	Stem	1,0737	1
5	Ball seat	POM	2
6	Handle	ZINC	1
7	Washer	1,0116	1
8	Washer	1,0116	1
9	Stem ring	POM	1
10	Spine	1,0737	1
11	Seeger	1,4301	1
12	Adapter o-ring	NBR	2
13	Stem o-ring	NBR	1
14	Screw	Din 6921 8.8	1
15	Caps	PVC	2

For further special requests please consult our technical/commercial service

- On request**
- Reduced bore
 - O-Ring in FKM, EPDM, HNBR, KALREZ
 - Seals in PTFE, PEEK, PA612, GEMPTFE, METAL TO METAL
 - Special threads
 - Stem in stainless steel 1,4404
 - Ball in stainless steel 1,4404
 - Pressure class up to PN50 MPa
 - Pneumatic and electrical actuator
 - Security block
 - Locking device

"The company reserves the right to operate dimensional changes without prior notice".

+ GE2

2-WAY HIGH PRESSURE BALL VALVES



CARBON STEEL

- Type: ball valve GE 2 way
- Body: block
- Material: 1,0737
- Ball seats: from DN4 up to DN25
- O-Rings: NBR, FKM, EPDM, MVQ
- Operating pressure: 500 Bar depending on valve size and seal materials selected
- Temp range: -20°C to +100°C depending on seal material selected

GE2 G 1/2 DN13 1 1 1 1 A B

Type and way of valve	GAS DIN/ISO 228 BSP	NPT ANSI/ASME B1.20.1	SAE J1926-1	DIN 2353 HEAVY SERIES	DIN 2353 LIGHT SERIES	Nominal dimension	Body material	Adapter material	Stem material	Ball material	Ball seat material	Adapter and stem seal material
GE2 2-way	G 1/8	N 1/8	SAE4	8S	6L	DN4	1 1,0737	1 1,0737	1 1,0737	1 1,0737	A POM D PEEK G PA612 K GEMPTFE C PTFE	B NBR E FKM F EPDM L MVQ
	G 1/4	N 1/4	SAE6	10S	8L	DN6						
	G 3/8	N 3/8	SAE8	12S	10L	DN10						
	G 1/2	N 1/2	SAE12	14S	12L	DN13						
	G 3/4	N 3/4	SAE16	16S	15L	DN20						
	G 1	N 1	SAE20R	20S	18L	DN25						
	G 1 1/4 R	N 1 1/4 R	SAE24R	25S	22L							
	G 1 1/2 R	N 1 1/2 R		30S	28L							
				38S	35L							
					42L							

STAINLESS STEEL

- Type: ball valve GE 2 way
- Body: block
- Material: 1,4404
- Ball seats: from DN4 up to DN25
- O-Rings: NBR, FKM, EPDM, MVQ
- Operating pressure: 500 Bar depending on valve size and seal materials selected
- Temp range: -30°C to +100°C different temperatures on request

GE2 G 1/2 DN13 4 4 4 4 A B

Type and way of valve	GAS DIN/ISO 228 BSP	NPT ANSI/ASME B1.20.1	SAE J1926-1	DIN 2353 HEAVY SERIES	DIN 2353 LIGHT SERIES	Nominal dimension	Body material	Adapter material	Stem material	Ball material	Ball seat material	Adapter and stem seal material
GE2 2-way	G 1/8	N 1/8	SAE4	8S	6L	DN4	4 1,4404	4 1,4404	4 1,4404	4 1,4404	A POM D PEEK G PA612 K GEMPTFE C PTFE	B NBR E FKM F EPDM L MVQ
	G 1/4	N 1/4	SAE6	10S	8L	DN6						
	G 3/8	N 3/8	SAE8	12S	10L	DN10						
	G 1/2	N 1/2	SAE12	14S	12L	DN13						
	G 3/4	N 3/4	SAE16	16S	15L	DN20						
	G 1	N 1	SAE20R	20S	18L	DN25						
	G 1 1/4 R	N 1 1/4 R	SAE24R	25S	22L							
	G 1 1/2 R	N 1 1/2 R		30S	28L							
				38S	35L							
					42L							

"The company reserves the right to operate dimensional changes without prior notice".



2-WAY HIGH PRESSURE BALL VALVES

Specialist in Ball Valves

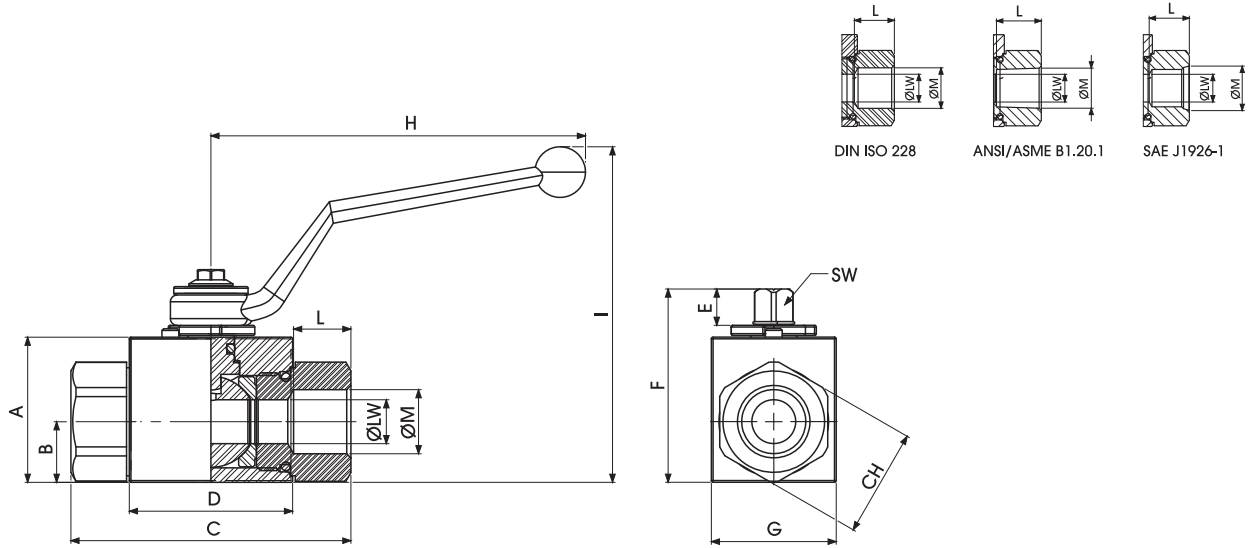

GE2 DIN/ISO 228 BSP

Standard

																	CARBON STEEL	STAINLESS STEEL	
TYPE	PN	DN	A	B	C	D	E	F	G	H	I	L	ØM	CH	SW	ØLW	KG	ITEM CODE	ITEM CODE
GE2 G 1/8	50 MPa	4	35	14,5	71	42,4	11	49	30	110	91,5	11	G 1/8	24	9	4	0,512	GE2GGT05011A000	GE2GGT05044A000
GE2 G 1/4	50 MPa	6	35	14,5	71	42,4	11	49	30	110	91,5	15,5	G 1/4	24	9	6	0,497	GE2GGT15011A000	GE2GGT15044A000
GE2 G 3/8	50 MPa	10	40	17,4	73	44,4	11	54,25	35	110	96,5	15,5	G 3/8	30	9	10	0,652	GE2GGT25011A000	GE2GGT25044A000
GE2 G 1/2	50 MPa	13	43	18	83	48,4	11	57	37	110	99,5	17	G 1/2	32	9	13	0,77	GE2GGT35011A000	GE2GGT35044A000
GE2 G 3/4	40 MPa	20	57	23,4	95	62,5	14	73,5	49	180	106,5	21	G 3/4	41	14	20	1,46	GE2GGT44011A000	GE2GGT44044A000
GE2 G 1	35 MPa	25	65	29,5	112	66,5	14	83,5	55	180	116,5	24	G 1	50	14	25	2,23	GE2GGT53011A000	GE2GGT53044A000
GE2 G 1 1/4 R	35 MPa	25	65	29,5	120	66,5	14	83,5	55	180	116,5	24	G 1 1/4	55	14	25	2,299	GE2GGR63011A000	GE2GGR63044A000
GE2 G 1 1/2 R	35 MPa	25	65	29,5	124	66,5	14	83,5	55	180	116,5	24	G 1 1/2	60	14	25	2,413	GE2GGR73011A000	GE2GGR73044A000

GE2 ANSI/ASME B1.20.1 NPT

Standard

																	CARBON STEEL	STAINLESS STEEL	
TYPE	PN	DN	A	B	C	D	E	F	G	H	I	L	ØM	CH	SW	ØLW	KG	ITEM CODE	ITEM CODE
GE2 N 1/8	50 MPa	4	35	14,5	71	42,4	11	49	30	110	91,5	11	N 1/8	24	9	4	0,512	GE2NNT05011A000	GE2NNT05044A000
GE2 N 1/4	50 MPa	6	35	14,5	71	42,4	11	49	30	110	91,5	17	N 1/4	24	9	6	0,5	GE2NNT15011A000	GE2NNT15044A000
GE2 N 3/8	50 MPa	10	40	17,4	73	44,4	11	54,25	35	110	96,5	17	N 3/8	30	9	10	0,655	GE2NNT25011A000	GE2NNT25044A000
GE2 N 1/2	50 MPa	13	43	18	83	48,4	11	57	37	110	99,5	21	N 1/2	32	9	13	0,771	GE2NNT35011A000	GE2NNT35044A000
GE2 N 3/4	40 MPa	20	57	23,4	95	62,5	14	73,5	49	180	106,5	21	N 3/4	41	14	20	1,478	GE2NNT44011A000	GE2NNT44044A000
GE2 N 1	35 MPa	25	65	29,5	112	66,5	14	83,5	55	180	116,5	24	N 1	50	14	25	2,279	GE2NNT53011A000	GE2NNT53044A000
GE2 N 1 1/4 R	35 MPa	25	65	29,5	120	66,5	14	83,5	55	180	116,5	24	N 1 1/4	55	14	25	2,351	GE2NNR63011A000	GE2NNR63044A000
GE2 N 1 1/2 R	35 MPa	25	65	29,5	124	66,5	14	83,5	55	180	116,5	24	N 1 1/2	60	14	25	2,482	GE2NNR73011A000	GE2NNR73044A000

GE2 SAE J1926-1

Standard

																	CARBON STEEL	STAINLESS STEEL	
TYPE	PN	DN	A	B	C	D	E	F	G	H	I	L	ØM	CH	SW	ØLW	KG	ITEM CODE	ITEM CODE
GE2 SAE4	50 MPa	6	35	14,5	71	42,4	11	49	30	110	91,5	15,5	7/16 UNF	24	9	6	0,504	GE2EEE05011A000	GE2EEE05044A000
GE2 SAE6	50 MPa	10	40	17,4	73	44,4	11	54,25	35	110	96,5	16	9/16 UNF	30	9	10	0,663	GE2EEE15011A000	GE2EEE15044A000
GE2 SAE8	50 MPa	13	43	18	83	48,4	11	57	37	110	99,5	17,5	3/4 UNF	32	9	13	0,779	GE2EEE25011A000	GE2EEE25044A000
GE2 SAE12	40 MPa	20	57	23,4	95	62,5	14	73,5	49	180	106,5	23	1 1/16 UNF	41	14	20	1,441	GE2EEE34011A000	GE2EEE34044A000
GE2 SAE16	35 MPa	25	65	29,5	112	66,5	14	83,5	55	180	116,5	23	1 5/16 UNF	50	14	25	2,335	GE2EEE43011A000	GE2EEE43044A000
GE2 SAE20R	35 MPa	25	65	29,5	120	66,5	14	83,5	55	180	116,5	23	1 5/8 UNF	55	14	25	2,307	GE2EEE53011A000	GE2EEE53044A000
GE2 SAE24R	35 MPa	25	65	29,5	124	66,5	14	83,5	55	180	116,5	23	1 7/8 UNF	60	14	25	2,399	GE2EEE63011A000	GE2EEE63044A000

"The company reserves the right to operate dimensional changes without prior notice".

+ GE2

2-WAY HIGH PRESSURE BALL VALVES

www.gemels.it

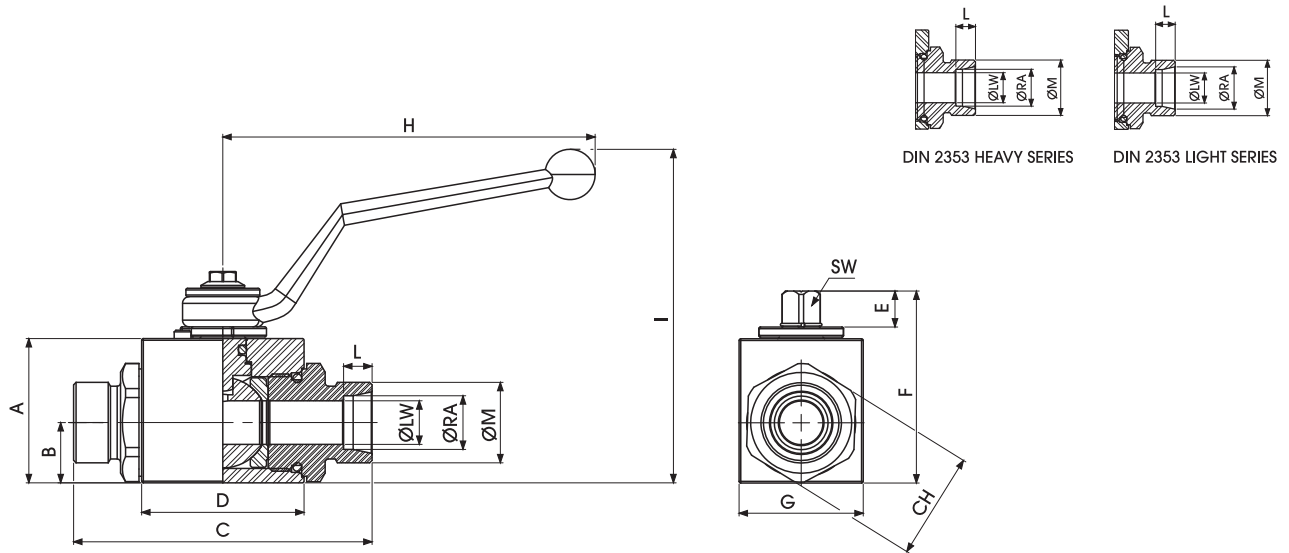

GE2 DIN 2353 HEAVY SERIES

Standard

																	CARBON STEEL	STAINLESS STEEL		
TYPE	PN	DN	A	B	C	D	E	F	G	H	I	L	ØM	CH	SW	ØLW	ØRA	KG	ITEM CODE	ITEM CODE
GE2 8S	50 MPa	4	35	14,5	76	42,4	11	49	30	110	91,5	7	M16x1,5	24	9	4	8	0,501	GE2DDS05011A000	GE2DDS05044A000
GE2 10S	50 MPa	6	35	14,5	76	42,4	11	49	30	110	91,5	7,5	M18x1,5	24	9	6	10	0,501	GE2DDS15011A000	GE2DDS15044A000
GE2 12S	50 MPa	8	35	14,5	76	42,4	11	49	30	110	91,5	7,5	M20x1,5	24	9	8	12	0,501	GE2DDRS5011A000	GE2DDRS5044A000
GE2 12S	50 MPa	10	40	17,4	76	44,4	11	54,25	35	110	96,5	7,5	M20x1,5	30	9	10	12	0,599	GE2DDS25011A000	GE2DDS25044A000
GE2 14S	50 MPa	10	40	17,4	82,5	44,4	11	54,25	35	110	96,5	8	M22x1,5	30	9	10	14	0,629	GE2DDS35011A000	GE2DDS35044A000
GE2 16S	50 MPa	13	43	18	89	48,4	11	57	37	110	99,5	8,5	M24x1,5	32	9	13	16	0,67	GE2DDS45011A000	GE2DDS45044A000
GE2 20S	50 MPa	13	43	18	93	48,4	11	57	37	110	99,5	10,5	M30x2	32	9	13	20	0,786	GE2DDS55011A000	GE2DDS55044A000
GE2 25S	40 MPa	20	57	23,4	111	62,5	14	73,5	49	180	106,5	12	M36x2	41	14	20	25	1,485	GE2DDS64011A000	GE2DDS64044A000
GE2 30S	35 MPa	25	65	29,5	121	66,5	14	83,5	55	180	116,5	13	M42x2	50	14	25	30	2,145	GE2DDS73011A000	GE2DDS73044A000
GE2 38S	35 MPa	25	65	29,5	131	66,5	14	83,5	55	180	116,5	16	M52x2	55	14	25	38	2,373	GE2DDS83011A000	GE2DDS83044A000

GE2 DIN 2353 LIGHT SERIES

Standard

																	CARBON STEEL	STAINLESS STEEL		
TYPE	PN	DN	A	B	C	D	E	F	G	H	I	L	ØM	CH	SW	ØLW	ØRA	KG	ITEM CODE	ITEM CODE
GE2 6L	50 MPa	6	35	14,5	76	42,4	11	49	30	110	91,5	7	M12x1,5	24	9	6	6	0,475	GE2DDL05011A000	GE2DDL05044A000
GE2 8L	50 MPa	6	35	14,5	76	42,4	11	49	30	110	91,5	7	M14x1,5	24	9	6	8	0,477	GE2DDL15011A000	GE2DDL15044A000
GE2 10L	50 MPa	6	35	14,5	76	42,4	11	49	30	110	91,5	7	M16x1,5	24	9	6	10	0,475	GE2DDR15011A000	GE2DDR15044A000
GE2 10L	50 MPa	10	40	17,4	76,5	44,4	11	54,25	35	110	96,5	7	M16x1,5	30	9	10	10	0,597	GE2DDL25011A000	GE2DDL25044A000
GE2 12L	50 MPa	10	40	17,4	79,5	44,4	11	54,25	35	110	96,5	7	M18x1,5	30	9	10	12	0,616	GE2DDL35011A000	GE2DDL35044A000
GE2 15L	50 MPa	13	43	18	87	48,4	11	57	37	110	99,5	7	M22x1,5	32	9	13	15	0,731	GE2DDL45011A000	GE2DDL45044A000
GE2 18L	50 MPa	13	43	18	87	48,4	11	57	37	110	99,5	7,5	M26x1,5	32	9	13	18	0,748	GE2DDL55011A000	GE2DDL55044A000
GE2 22L	40 MPa	20	57	23,4	110	62,5	14	73,5	49	180	106,5	7,5	M30x2	41	14	20	22	1,463	GE2DDL64011A000	GE2DDL64044A000
GE2 28L	35 MPa	25	65	29,5	117	66,5	14	83,5	55	180	116,5	7,5	M36x2	50	14	25	28	2,131	GE2DDL73011A000	GE2DDL73044A000
GE2 35L	35 MPa	25	65	29,5	119	66,5	14	83,5	55	180	116,5	10,5	M45x2	50	14	25	35	2,163	GE2DDL83011A000	GE2DDL83044A000
GE2 42L	35 MPa	25	65	29,5	119	66,5	14	83,5	55	180	116,5	11	M52x2	55	14	25	42	2,256	GE2DDL93011A000	GE2DDL93044A000



2-WAY HIGH PRESSURE BALL VALVES

Specialist in Ball Valves

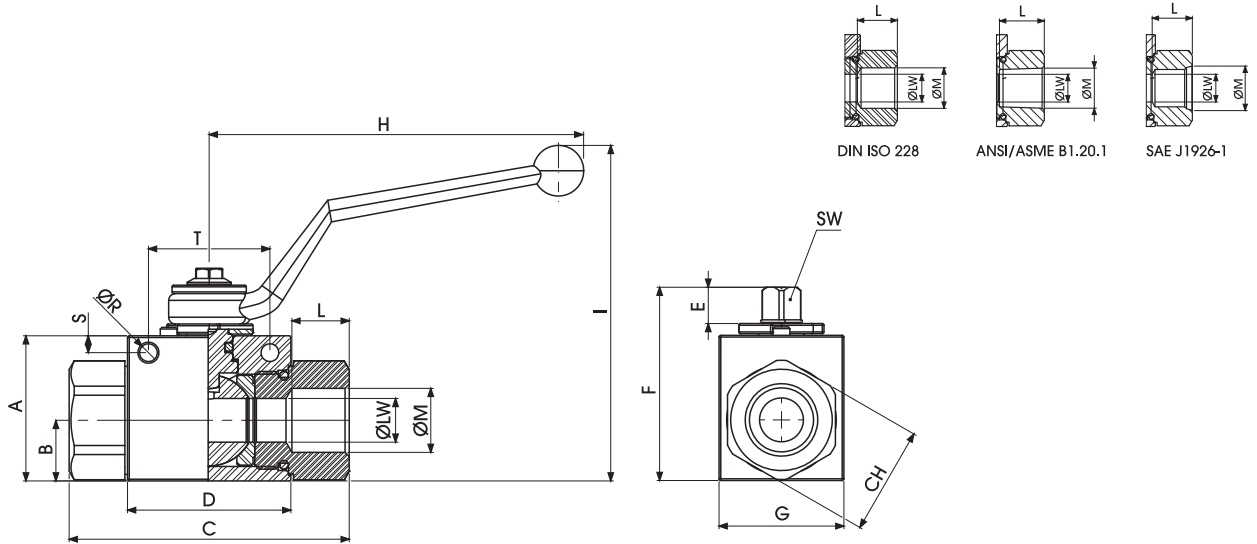

GE2 DIN/ISO 228 BSP

Fixing holes

																			CARBON STEEL	STAINLESS STEEL		
TYPE	PN	DN	A	B	C	D	E	F	G	H	I	L	ØM	CH	ØR	S	T	SW	ØLW	KG	ITEM CODE	ITEM CODE
GE2 G 1/8	50 MPa	4	35	14,5	71	42,4	11	49	30	110	91,5	11	G 1/8	24	5,25	4,5	34	9	4	0,505	GE2GGT05011AF10	GE2GGT05044AF10
GE2 G 1/4	50 MPa	6	35	14,5	71	42,4	11	49	30	110	91,5	15,5	G 1/4	24	5,25	4,5	34	9	6	0,49	GE2GGT15011AF10	GE2GGT15044AF10
GE2 G 3/8	50 MPa	10	40	17,4	73	44,4	11	54,25	35	110	96,5	15,5	G 3/8	30	5,25	4,5	34	9	10	0,644	GE2GGT25011AF10	GE2GGT25044AF10
GE2 G 1/2	50 MPa	13	43	18	83	48,4	11	57	37	110	99,5	17	G 1/2	32	5,25	5	36	9	13	0,757	GE2GGT35011AF10	GE2GGT35044AF10
GE2 G 3/4	40 MPa	20	57	23,4	95	62,5	14	73,5	49	180	106,5	21	G 3/4	41	6,25	6	50	14	20	1,438	GE2GGT44011AF10	GE2GGT44044AF10
GE2 G 1	35 MPa	25	65	29,5	112	66,5	14	83,5	55	180	116,5	24	G 1	50	6,25	6	50	14	25	2,223	GE2GGT53011AF10	GE2GGT53044AF10
GE2 G 1 1/4 R	35 MPa	25	65	29,5	120	66,5	14	83,5	55	180	116,5	24	G 1 1/4	55	6,25	6	50	14	25	2,273	GE2GGR63011AF10	GE2GGR63044AF10
GE2 G 1 1/2 R	35 MPa	25	65	29,5	124	66,5	14	83,5	55	180	116,5	24	G 1 1/2	60	6,25	6	50	14	25	2,386	GE2GGR73011AF10	GE2GGR73044AF10

GE2 ANSI/ASME B1.20.1 NPT

Fixing holes

																			CARBON STEEL	STAINLESS STEEL		
TYPE	PN	DN	A	B	C	D	E	F	G	H	I	L	ØM	CH	ØR	S	T	SW	ØLW	KG	ITEM CODE	ITEM CODE
GE2 N 1/8	50 MPa	4	35	14,5	71	42,4	11	49	30	110	91,5	11	N 1/8	24	5,25	4,5	34	9	4	0,505	GE2NNT05011AF10	GE2NNT05044AF10
GE2 N 1/4	50 MPa	6	35	14,5	71	42,4	11	49	30	110	91,5	17	N 1/4	24	5,25	4,5	34	9	6	0,49	GE2NNT15011AF10	GE2NNT15044AF10
GE2 N 3/8	50 MPa	10	40	17,4	73	44,4	11	54,25	35	110	96,5	17	N 3/8	30	5,25	4,5	34	9	10	0,644	GE2NNT25011AF10	GE2NNT25044AF10
GE2 N 1/2	50 MPa	13	43	18	83	48,4	11	57	37	110	99,5	21	N 1/2	32	5,25	5	36	9	13	0,757	GE2NNT35011AF10	GE2NNT35044AF10
GE2 N 3/4	40 MPa	20	57	23,4	95	62,5	14	73,5	49	180	106,5	21	N 3/4	41	6,25	6	50	14	20	1,438	GE2NNT44011AF10	GE2NNT44044AF10
GE2 N 1	35 MPa	25	65	29,5	112	66,5	14	83,5	55	180	116,5	24	N 1	50	6,25	6	50	14	25	2,223	GE2NNT53011AF10	GE2NNT53044AF10
GE2 N 1 1/4 R	35 MPa	25	65	29,5	120	66,5	14	83,5	55	180	116,5	24	N 1 1/4	55	6,25	6	50	14	25	2,273	GE2NNR63011AF10	GE2NNR63044AF10
GE2 N 1 1/2 R	35 MPa	25	65	29,5	124	66,5	14	83,5	55	180	116,5	24	N 1 1/2	60	6,25	6	50	14	25	2,386	GE2NNR73011AF10	GE2NNR73044AF10

GE2 SAE J1926-1

Fixing holes

																			CARBON STEEL	STAINLESS STEEL		
TYPE	PN	DN	A	B	C	D	E	F	G	H	I	L	ØM	CH	ØR	S	T	SW	ØLW	KG	ITEM CODE	ITEM CODE
GE2 SAE4	50 MPa	6	35	14,5	71	42,4	11	49	30	110	91,5	15,5	7/16 UNF	24	5,25	4,5	34	9	6	0,49	GE2EEE05011AF10	GE2EEE05044AF10
GE2 SAE6	50 MPa	10	40	17,4	73	44,4	11	54,25	35	110	96,5	16	9/16 UNF	30	5,25	4,5	34	9	10	0,644	GE2EEE15011AF10	GE2EEE15044AF10
GE2 SAE8	50 MPa	13	43	18	83	48,4	11	57	37	110	99,5	17,5	3/4 UNF	32	5,25	5	36	9	13	0,757	GE2EEE25011AF10	GE2EEE25044AF10
GE2 SAE12	40 MPa	20	57	23,4	95	62,5	14	73,5	49	180	106,5	23	1 1/16 UNF	41	6,25	6	50	14	20	1,438	GE2EEE34011AF10	GE2EEE34044AF10
GE2 SAE16	35 MPa	25	65	29,5	112	66,5	14	83,5	55	180	116,5	23	1 5/16 UNF	50	6,25	6	50	14	25	2,223	GE2EEE43011AF10	GE2EEE43044AF10
GE2 SAE20R	35 MPa	25	65	29,5	120	66,5	14	83,5	55	180	116,5	23	1 5/8 UNF	55	6,25	6	50	14	25	2,273	GE2EEE53011AF10	GE2EEE53044AF10
GE2 SAE24R	35 MPa	25	65	29,5	124	66,5	14	83,5	55	180	116,5	23	1 7/8 UNF	60	6,25	6	50	14	25	2,386	GE2EEE63011AF10	GE2EEE63044AF10

"The company reserves the right to operate dimensional changes without prior notice".

+ GE2

2-WAY HIGH PRESSURE BALL VALVES

www.gemels.it

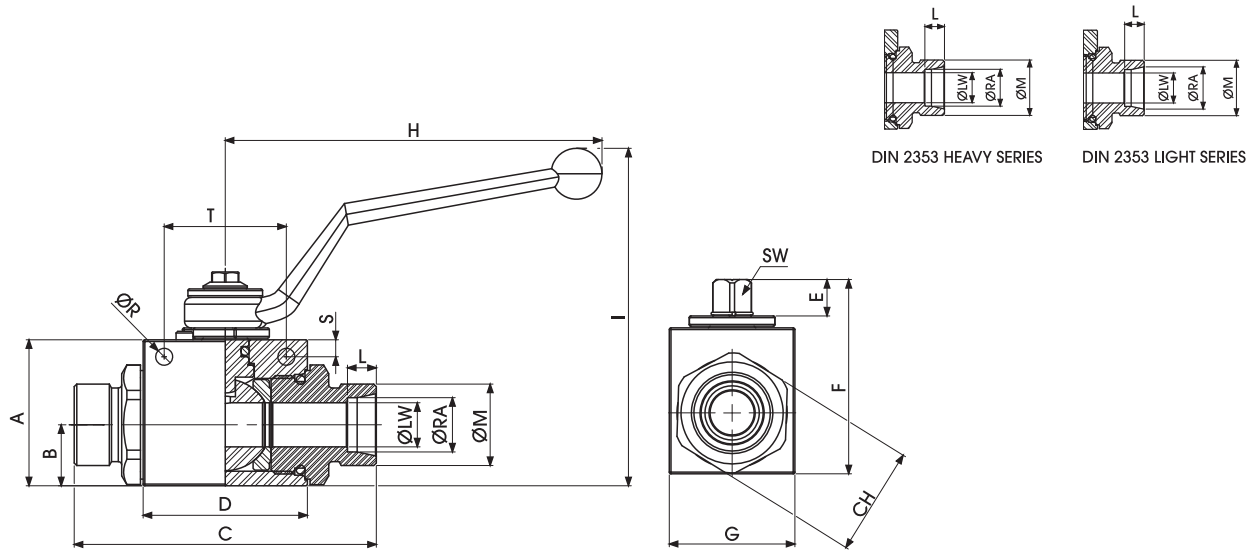

GE2 DIN 2353 HEAVY SERIES

Fixing holes

CARBON STEEL STAINLESS STEEL

TYPE	PN	DN	A	B	C	D	E	F	G	H	I	L	ØM	CH	ØR	S	T	SW	ØLW	ØRA	KG	ITEM CODE	ITEM CODE
GE2 8S	50 MPa	4	35	14,5	76	42,4	11	49	30	110	91,5	7	M16x1,5	24	4,25	4	34	9	4	8	0,405	GE2DDS05011AF10	GE2DDS05044AF10
GE2 10S	50 MPa	6	35	14,5	76	42,4	11	49	30	110	91,5	7,5	M18x1,5	24	4,25	4	34	9	6	10	0,47	GE2DDS15011AF10	GE2DDS15044AF10
GE2 12S	50 MPa	8	35	14,5	76	42,4	11	49	30	110	91,5	7,5	M20x1,5	24	4,25	4	34	9	8	12	0,468	GE2DRS5011AF10	GE2DRS5044AF10
GE2 12S	50 MPa	10	40	17,4	76	44,4	11	54,25	35	110	96,5	7,5	M20x1,5	30	4,25	4	34	9	10	12	0,589	GE2DDS25011AF10	GE2DDS25044AF10
GE2 14S	50 MPa	10	40	17,4	83	44,4	11	54,25	35	110	96,5	8	M22x1,5	30	4,25	4	34	9	10	14	0,608	GE2DDS35011AF10	GE2DDS35044AF10
GE2 16S	50 MPa	13	43	18	89	48,4	11	57	37	110	99,5	8,5	M24x1,5	32	5,25	5	36	9	13	16	0,72	GE2DDS45011AF10	GE2DDS45044AF10
GE2 20S	50 MPa	13	43	18	93	48,4	11	57	37	110	99,5	10,5	M30x2	32	5,25	5	36	9	13	20	0,737	GE2DDS55011AF10	GE2DDS55044AF10
GE2 25S	40 MPa	20	57	23,4	111	62,5	14	73,5	49	180	106,5	12	M36x2	41	6,25	6	50	14	20	25	1,463	GE2DDS64011AF10	GE2DDS64044AF10
GE2 30S	35 MPa	25	65	29,5	121	66,5	14	83,5	55	180	116,5	13	M42x2	50	6,25	6	50	14	25	30	2,111	GE2DDS73011AF10	GE2DDS73044AF10
GE2 38S	35 MPa	25	65	29,5	131	66,5	14	83,5	55	180	116,5	16	M52x2	55	6,25	6	50	14	25	38	2,143	GE2DDS83011AF10	GE2DDS83044AF10

GE2 DIN 2353 LIGHT SERIES

Fixing holes

CARBON STEEL STAINLESS STEEL

TYPE	PN	DN	A	B	C	D	E	F	G	H	I	L	ØM	CH	ØR	S	T	SW	ØLW	ØRA	KG	ITEM CODE	ITEM CODE
GE2 6L	50 MPa	6	35	14,5	76	42,4	11	49	30	110	91,5	7	M12x1,5	24	5,25	4,5	34	9	6	6	0,405	GE2DDL05011AF10	GE2DDL05044AF10
GE2 8L	50 MPa	6	35	14,5	76	42,4	11	49	30	110	91,5	7	M14x1,5	24	5,25	4,5	34	9	6	8	0,47	GE2DDL15011AF10	GE2DDL15044AF10
GE2 10L	50 MPa	6	35	14,5	76	42,4	11	49	30	110	91,5	7	M16x1,5	24	5,25	4,5	34	9	6	10	0,468	GE2DRL5011AF10	GE2DRL5044AF10
GE2 10L	50 MPa	10	40	17,4	77	44,4	11	54,25	35	110	96,5	7	M16x1,5	30	5,25	4,5	34	9	10	10	0,589	GE2DDL25011AF10	GE2DDL25044AF10
GE2 12L	50 MPa	10	40	17,4	80	44,4	11	54,25	35	110	96,5	7	M18x1,5	30	5,25	4,5	34	9	10	12	0,608	GE2DDL35011AF10	GE2DDL35044AF10
GE2 15L	50 MPa	13	43	18	87	48,4	11	57	37	110	99,5	7	M22x1,5	32	5,25	5	36	9	13	15	0,72	GE2DDL45011AF10	GE2DDL45044AF10
GE2 18L	50 MPa	13	43	18	87	48,4	11	57	37	110	99,5	7,5	M26x1,5	32	5,25	5	36	9	13	18	0,737	GE2DDL55011AF10	GE2DDL55044AF10
GE2 22L	40 MPa	20	57	23,4	110	62,5	14	73,5	49	180	106,5	7,5	M30x2	41	6,25	6	50	14	20	22	1,463	GE2DDL64011AF10	GE2DDL64044AF10
GE2 28L	35 MPa	25	65	29,5	117	66,5	14	83,5	55	180	116,5	7,5	M36x2	50	6,25	6	50	14	25	28	2,111	GE2DDL73011AF10	GE2DDL73044AF10
GE2 35L	35 MPa	25	65	29,5	119	66,5	14	83,5	55	180	116,5	10,5	M45x2	50	6,25	6	50	14	25	35	2,143	GE2DDL83011AF10	GE2DDL83044AF10
GE2 42L	35 MPa	25	65	29,5	119	66,5	14	83,5	55	180	116,5	11	M52x2	55	6,25	6	50	14	25	42	2,236	GE2DDL93011AF10	GE2DDL93044AF10



2-WAY HIGH PRESSURE BALL VALVES

Specialist in Ball Valves

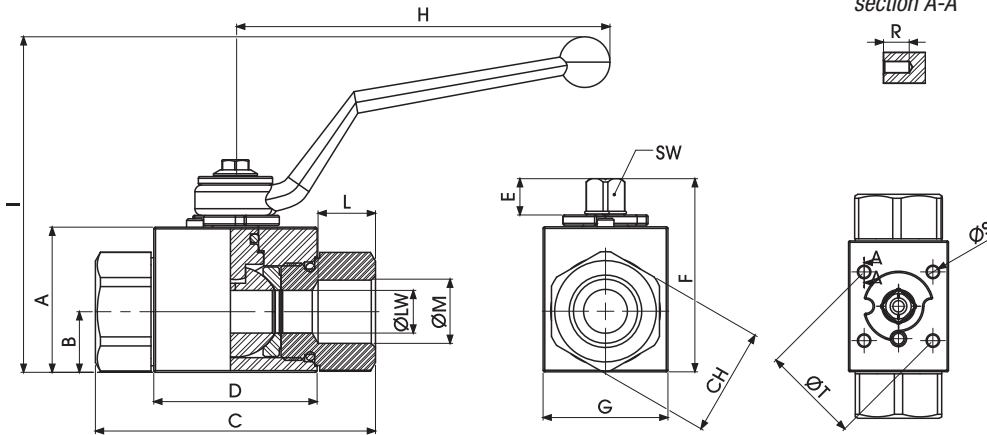
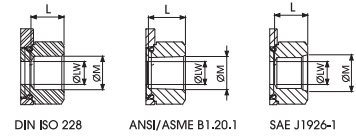

GE2 DIN/ISO 228 BSP

Fixing holes DIN/ISO5211

																				CARBON STEEL	STAINLESS STEEL		
TYPE	PN	DN	A	B	C	D	E	F	G	H	I	L	ØM	CH	R	ØS	ØT	ISO5211	SW	LW	KG	ITEM CODE	ITEM CODE
GE2 G 1/8	50 MPa	4	35	14,5	71	42,4	11	49	30	110	91,5	11	G 1/8	24	9	M4	35	F03	9	4	0,505	GE2GGT05011AF50	GE2GGT05044AF50
GE2 G 1/4	50 MPa	6	35	14,5	71	42,4	11	49	30	110	91,5	15,5	G 1/4	24	9	M4	35	F03	9	6	0,49	GE2GGT15011AF50	GE2GGT15044AF50
GE2 G 3/8	50 MPa	10	40	17,4	73	44,4	11	54,25	35	110	96,5	15,5	G 3/8	30	9	M5	36	F03	9	10	0,644	GE2GGT25011AF50	GE2GGT25044AF50
GE2 G 1/2	50 MPa	13	43	18	83	48,4	11	57	37	110	99,5	17	G 1/2	32	9	M5	36	F03	9	13	0,757	GE2GGT35011AF50	GE2GGT35044AF50
GE2 G 3/4	40 MPa	20	57	23,4	95	62,5	14	73,5	49	180	106,5	21	G 3/4	41	15	M6	50	F05	14	20	1,438	GE2GGT44011AF50	GE2GGT44044AF50
GE2 G 1	35 MPa	25	65	29,5	112	66,5	14	83,5	55	180	116,5	24	G 1	50	15	M6	50	F05	14	25	2,223	GE2GGT53011AF50	GE2GGT53044AF50
GE2 G 1 1/4 R	35 MPa	25	65	29,5	120	66,5	14	83,5	55	180	116,5	24	G 1 1/4	55	15	M6	50	F05	14	25	2,273	GE2GGR63011AF50	GE2GGR63044AF50
GE2 G 1 1/2 R	35 MPa	25	65	29,5	124	66,5	14	83,5	55	180	116,5	24	G 1 1/2	60	15	M6	50	F05	14	25	2,386	GE2GGR73011AF50	GE2GGR73044AF50

GE2 ANSI/ASME B1.20.1 NPT

Fixing holes DIN/ISO5211

																				CARBON STEEL	STAINLESS STEEL		
TYPE	PN	DN	A	B	C	D	E	F	G	H	I	L	ØM	CH	R	ØS	ØT	ISO5211	SW	LW	KG	ITEM CODE	ITEM CODE
GE2 N 1/8	50 MPa	4	35	14,5	71	42,4	11	49	30	110	91,5	11	N 1/8	24	9	M4	35	F03	9	4	0,505	GE2NNT05011AF50	GE2NNT05044AF50
GE2 N 1/4	50 MPa	6	35	14,5	71	42,4	11	49	30	110	91,5	17	N 1/4	24	9	M4	35	F03	9	6	0,49	GE2NNT15011AF50	GE2NNT15044AF50
GE2 N 3/8	50 MPa	10	40	17,4	73	44,4	11	54,25	35	110	96,5	17	N 3/8	30	9	M5	36	F03	9	10	0,644	GE2NNT25011AF50	GE2NNT25044AF50
GE2 N 1/2	50 MPa	13	43	18	83	48,4	11	57	37	110	99,5	21	N 1/2	32	9	M5	36	F03	9	13	0,757	GE2NNT35011AF50	GE2NNT35044AF50
GE2 N 3/4	40 MPa	20	57	23,4	95	62,5	14	73,5	49	180	106,5	21	N 3/4	41	15	M6	50	F05	14	20	1,438	GE2NNT44011AF50	GE2NNT44044AF50
GE2 N 1	35 MPa	25	65	29,5	112	66,5	14	83,5	55	180	116,5	24	N 1	50	15	M6	50	F05	14	25	2,223	GE2NNT53011AF50	GE2NNT53044AF50
GE2 N 1 1/4 R	35 MPa	25	65	29,5	120	66,5	14	83,5	55	180	116,5	24	N 1 1/4	55	15	M6	50	F05	14	25	2,273	GE2NNR63011AF50	GE2NNR63044AF50
GE2 N 1 1/2 R	35 MPa	25	65	29,5	124	66,5	14	83,5	55	180	116,5	24	N 1 1/2	60	15	M6	50	F05	14	25	2,386	GE2NNR73011AF50	GE2NNR73044AF50

GE2 SAE J1926-1

Fixing holes DIN/ISO5211

																				CARBON STEEL	STAINLESS STEEL		
TYPE	PN	DN	A	B	C	D	E	F	G	H	I	L	ØM	CH	R	ØS	ØT	ISO5211	SW	LW	KG	ITEM CODE	ITEM CODE
GE2 SAE4	50 MPa	6	35	14,5	71	42,4	11	49	30	110	91,5	15,5	7/16 UNF	24	9	M4	35	F03	9	6	0,49	GE2EEE05011AF50	GE2EEE05044AF50
GE2 SAE6	50 MPa	10	40	17,4	73	44,4	11	54,25	35	110	96,5	16	9/16 UNF	30	9	M5	36	F03	9	10	0,644	GE2EEE15011AF50	GE2EEE15044AF50
GE2 SAE8	50 MPa	13	43	18	83	48,4	11	57	37	110	99,5	17,5	3/4 UNF	32	9	M5	36	F03	9	13	0,757	GE2EEE25011AF50	GE2EEE25044AF50
GE2 SAE12	40 MPa	20	57	23,4	95	62,5	14	73,5	49	180	106,5	23	1 1/16 UNF	41	15	M6	50	F05	14	20	1,438	GE2EEE34011AF50	GE2EEE34044AF50
GE2 SAE16	35 MPa	25	65	29,5	112	66,5	14	83,5	55	180	116,5	23	1 3/16 UNF	50	15	M6	50	F05	14	25	2,223	GE2EEE43011AF50	GE2EEE43044AF50
GE2 SAE20R	35 MPa	25	65	29,5	120	66,5	14	83,5	55	180	116,5	23	1 5/8 UNF	55	15	M6	50	F05	14	25	2,273	GE2EEE53011AF50	GE2EEE53044AF50
GE2 SAE24R	35 MPa	25	65	29,5	124	66,5	14	83,5	55	180	116,5	23	1 7/8 UNF	60	15	M6	50	F05	14	25	2,386	GE2EEE63011AF50	GE2EEE63044AF50

"The company reserves the right to operate dimensional changes without prior notice".

+ GE2

2-WAY HIGH PRESSURE BALL VALVES

www.gemels.it

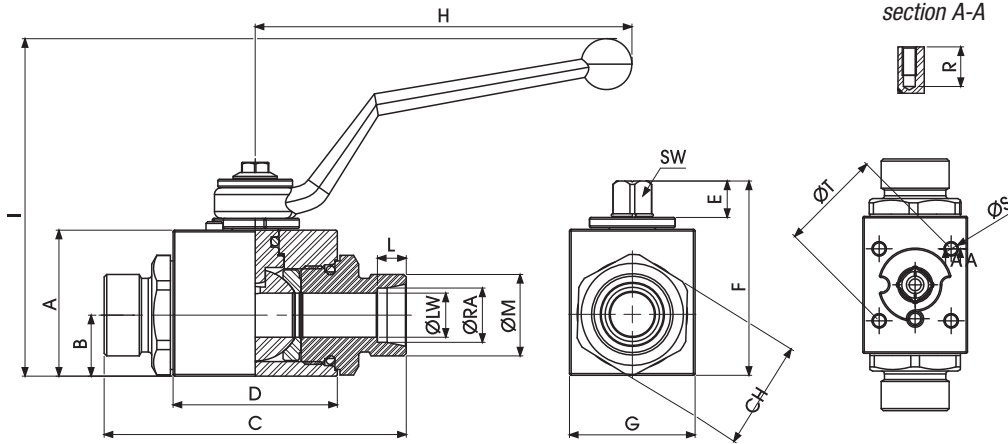
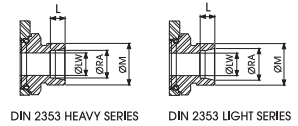

GE2 DIN 2353 HEAVY SERIES

Fixing holes DIN/ISO5211

																				CARBON STEEL	STAINLESS STEEL			
TYPE	PN	DN	A	B	C	D	E	F	G	H	I	L	ØM	CH	R	ØS	ØT	ISO5211	SW	ØLW	ØRA	KG	ITEM CODE	ITEM CODE
GE2 8S	50 MPa	4	35	14,5	76	42,4	11	49	30	110	91,5	7	M16x1,5	24	9	M4	35	F03	9	4	8	0,405	GE2DDS05011AF50	GE2DDS05044AF50
GE2 10S	50 MPa	6	35	14,5	76	42,4	11	49	30	110	91,5	7,5	M18x1,5	24	9	M4	35	F03	9	6	10	0,47	GE2DDS15011AF50	GE2DDS15044AF50
GE2 12S	50 MPa	8	35	14,5	76	42,4	11	49	30	110	91,5	7,5	M20x1,5	24	9	M4	35	F03	9	8	12	0,468	GE2DRS5011AF50	GE2DRS5044AF50
GE2 12S	50 MPa	10	40	17,4	76	44,4	11	54,25	35	110	96,5	7,5	M20x1,5	30	9	M5	36	F03	9	10	12	0,589	GE2DDS25011AF50	GE2DDS25044AF50
GE2 14S	50 MPa	10	40	17,4	83	44,4	11	54,25	35	110	96,5	8	M22x1,5	30	9	M5	36	F03	9	10	14	0,608	GE2DDS35011AF50	GE2DDS35044AF50
GE2 16S	50 MPa	13	43	18	89	48,4	11	57	37	110	99,5	8,5	M24x1,5	32	9	M5	36	F03	9	13	16	0,72	GE2DDS45011AF50	GE2DDS45044AF50
GE2 20S	50 MPa	13	43	18	93	48,4	11	57	37	110	99,5	10,5	M30x2	32	9	M5	36	F03	9	13	20	0,737	GE2DDS55011AF50	GE2DDS55044AF50
GE2 25S	40 MPa	20	57	23,4	111	62,5	14	73,5	49	180	106,5	12	M36x2	41	15	M6	50	F05	14	20	25	1,463	GE2DDS64011AF50	GE2DDS64044AF50
GE2 30S	35 MPa	25	65	29,5	121	66,5	14	83,5	55	180	116,5	13	M42x2	50	15	M6	50	F05	14	25	30	2,111	GE2DDS73011AF50	GE2DDS73044AF50
GE2 38S	35 MPa	25	65	29,5	131	66,5	14	83,5	55	180	116,5	16	M52x2	55	15	M6	50	F05	14	25	38	2,143	GE2DDS83011AF50	GE2DDS83044AF50

GE2 DIN 2353 LIGHT SERIES

Fixing holes DIN/ISO5211

																				CARBON STEEL	STAINLESS STEEL			
TYPE	PN	DN	A	B	C	D	E	F	G	H	I	L	ØM	CH	R	ØS	ØT	ISO5211	SW	ØLW	ØRA	KG	ITEM CODE	ITEM CODE
GE2 6L	50 MPa	6	35	14,5	76	42,4	11	49	30	110	91,5	7	M12x1,5	24	9	M4	35	F03	9	6	6	0,405	GE2DDL05011AF50	GE2DDL05044AF50
GE2 8L	50 MPa	6	35	14,5	76	42,4	11	49	30	110	91,5	7	M14x1,5	24	9	M4	35	F03	9	6	8	0,47	GE2DDL15011AF50	GE2DDL15044AF50
GE2 10L	50 MPa	6	35	14,5	76	42,4	11	49	30	110	91,5	7	M16x1,5	24	9	M4	35	F03	9	6	10	0,468	GE2DRRL5011AF50	GE2DRRL5044AF50
GE2 10L	50 MPa	10	40	17,4	77	44,4	11	54,25	35	110	96,5	7	M16x1,5	30	9	M5	36	F03	9	10	10	0,589	GE2DDL25011AF50	GE2DDL25044AF50
GE2 12L	50 MPa	10	40	17,4	80	44,4	11	54,25	35	110	96,5	7	M18x1,5	30	9	M5	36	F03	9	10	12	0,608	GE2DDL35011AF50	GE2DDL35044AF50
GE2 15L	50 MPa	13	43	18	87	48,4	11	57	37	110	99,5	7	M22x1,5	32	9	M5	36	F03	9	13	15	0,72	GE2DDL45011AF50	GE2DDL45044AF50
GE2 18L	50 MPa	13	43	18	87	48,4	11	57	37	110	99,5	12	M26x1,5	32	9	M5	36	F03	9	13	18	0,737	GE2DDL55011AF50	GE2DDL55044AF50
GE2 22L	40 MPa	20	57	23,4	110	62,5	14	73,5	49	180	106,5	14	M30x2	41	15	M6	50	F05	14	20	22	1,463	GE2DDL64011AF50	GE2DDL64044AF50
GE2 28L	35 MPa	25	65	29,5	117	66,5	14	83,5	55	180	116,5	14	M36x2	50	15	M6	50	F05	14	25	28	2,111	GE2DDL73011AF50	GE2DDL73044AF50
GE2 35L	35 MPa	25	65	29,5	119	66,5	14	83,5	55	180	116,5	16	M45x2	50	15	M6	50	F05	14	25	35	2,143	GE2DDL83011AF50	GE2DDL83044AF50
GE2 42L	35 MPa	25	65	29,5	119	66,5	14	83,5	55	180	116,5	16	M52x2	55	15	M6	50	F05	14	25	42	2,236	GE2DDL93011AF50	GE2DDL93044AF50

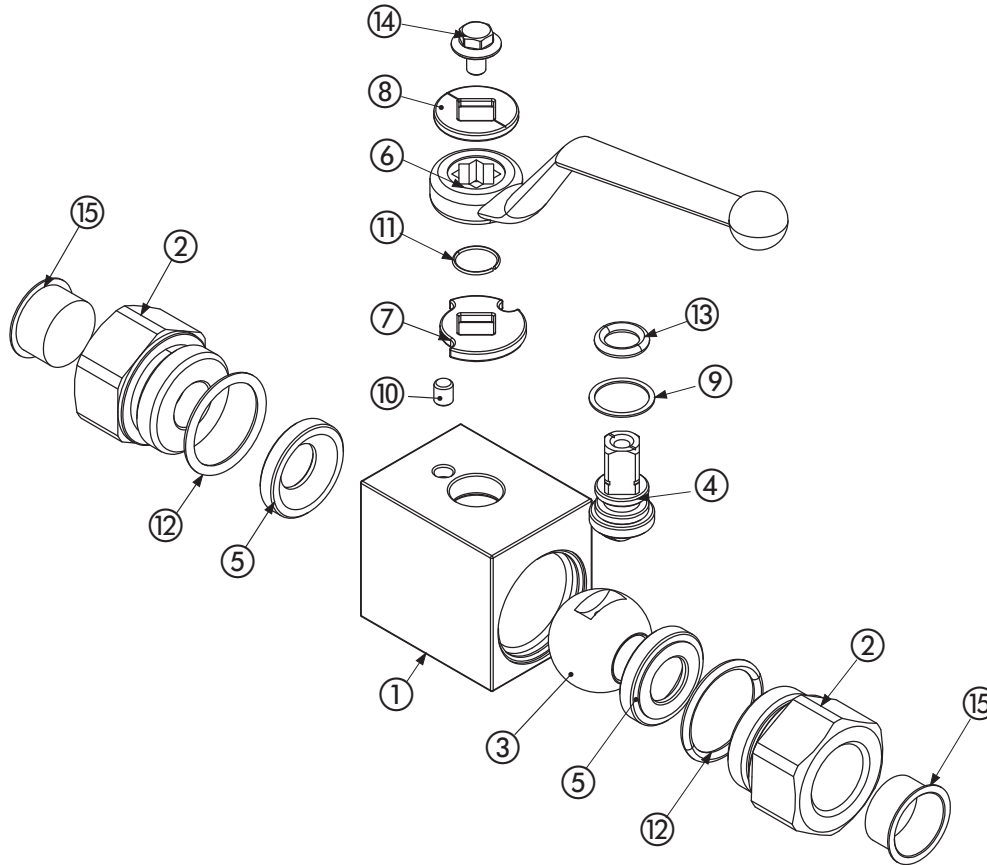

Carbon steel

Pos	Description	Material	Q.tà
1	Body	1,0737	1
2	Adapter	1,0737	2
3	Ball	1,0737	1
4	Stem	1,0737	1
5	Ball seat	POM	2
6	Handle	ZINC	1
7	Washer	1,0116	1
8	Washer	1,0116	1
9	Stem ring	POM	1
10	Spine	1,0737	1
11	Seeger	1,4301	1
12	Adapter o-ring	NBR	2
13	Stem o-ring	NBR	1
14	Screw	Din 6921 8.8	1
15	Caps	PVC	2

On request

- Reduced bore
- O-Ring in FKM, EPDM, HNBR, KALREZ
- Seals in PTFE, PEEK, PA612, GEMPTFE, METAL TO METAL
- Special threads
- Stem in stainless steel 1,4404
- Ball in stainless steel 1,4404
- Pressure class up to PN50 MPa
- Pneumatic and electrical actuator
- Security block
- Locking device

Stainless steel

Pos	Description	Material	Q.tà
1	Body	1,4404	1
2	Adapter	1,4404	2
3	Ball	1,4404	1
4	Stem	1,4404	1
5	Ball seat	POM	2
6	Handle	ZINC	1
7	Washer	1,4301	1
8	Washer	1,4301	1
9	Stem ring	POM	1
10	Spine	1,4301	1
11	Seeger	1,4301	1
12	Adapter o-ring	NBR	2
13	Stem o-ring	NBR	1
14	Screw	Din 6921 A2	1
15	Caps	PVC	2

On request

- Reduced bore
- O-Ring in FKM, EPDM, HNBR, KALREZ
- Seals in PTFE, PEEK, PA612, GEMPTFE, METAL TO METAL
- Special threads
- Pressure class up to PN50 MPa
- Pneumatic and electrical actuator
- Security block
- Locking device

For further special requests please consult our technical/commercial service

+ GE3

3-WAY HIGH PRESSURE BALL VALVES



CARBON STEEL

- Type: ball valve GE 3 way
- Body: block
- Material: 1,0737
- Ball seats: from DN4 up to DN25
- O-Rings: NBR, FKM, EPDM, MVQ
- Operating pressure: 500 Bar depending on valve size and seal materials selected
- Temp range: -20°C to +100°C depending on seal material selected

GE3	G 1/2		DN13		1	1	1	1	A	B		
Type and way of valve	GAS DIN/ISO 228 BSP	NPT ANSI/ASME B1.20.1	SAE J1926-1	DIN 2353 HEAVY SERIES	DIN 2353 LIGHT SERIES	Nominal dimension	Body material	Adapter material	Stem material	Ball material	Ball seat material	Adapter and stem seal material
GE3 3-way	G 1/8	N 1/8	SAE4	8S	6L	DN4	1 1,0737	1 1,0737	1 1,0737	1 1,0737	A POM D PEEK G PA612 K GEMPTFE C PTFE	B NBR E FKM F EPDM L MVQ
	G 1/4	N 1/4	SAE6	10S	8L	DN6						
	G 3/8	N 3/8	SAE8	12S	10L	DN10						
	G 1/2	N 1/2	SAE12	14S	12L	DN13						
	G 3/4	N 3/4	SAE16	16S	15L	DN20						
	G 1	N 1	SAE20R	20S	18L	DN25						
	G 1 1/4 R	N 1 1/4 R	SAE24R	25S	22L							
	G 1 1/2 R	N 1 1/2 R		30S	28L							
				38S	35L							
					42L							

STAINLESS STEEL

- Type: ball valve GE 3 way
- Body: block
- Material: 1,4404
- Ball seats: from DN4 up to DN25
- O-Rings: NBR, FKM, EPDM, MVQ
- Operating pressure: 500 Bar depending on valve size and seal materials selected
- Temp range: -30°C to +100°C different temperatures on request

GE3	G 1/2		DN13		4	4	4	4	A	B		
Type and way of valve	GAS DIN/ISO 228 BSP	NPT ANSI/ASME B1.20.1	SAE J1926-1	DIN 2353 HEAVY SERIES	DIN 2353 LIGHT SERIES	Nominal dimension	Body material	Adapter material	Stem material	Ball material	Ball seat material	Adapter and stem seal material
GE3 3-way	G 1/8	N 1/8	SAE4	8S	6L	DN4	4 1,4404	4 1,4404	4 1,4404	4 1,4404	A POM D PEEK G PA612 K GEMPTFE C PTFE	B NBR E FKM F EPDM L MVQ
	G 1/4	N 1/4	SAE6	10S	8L	DN6						
	G 3/8	N 3/8	SAE8	12S	10L	DN10						
	G 1/2	N 1/2	SAE12	14S	12L	DN13						
	G 3/4	N 3/4	SAE16	16S	15L	DN20						
	G 1	N 1	SAE20R	20S	18L	DN25						
	G 1 1/4 R	N 1 1/4 R	SAE24R	25S	22L							
	G 1 1/2 R	N 1 1/2 R		30S	28L							
				38S	35L							
					42L							

"The company reserves the right to operate dimensional changes without prior notice".

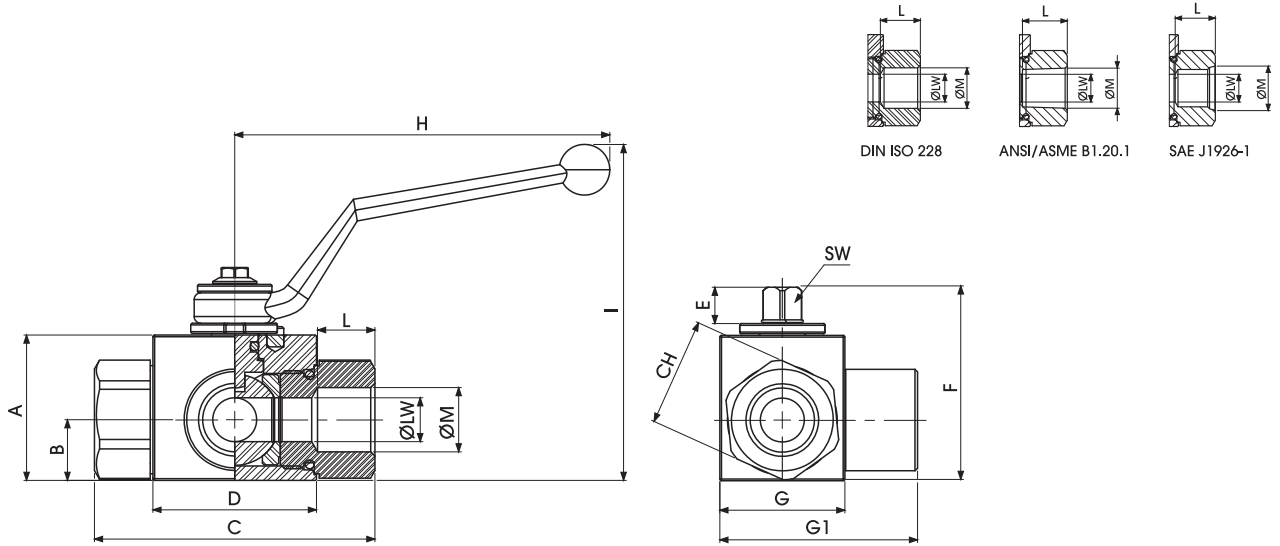

GE3 DIN/ISO 228 BSP

Standard

TYPE	PN	DN	A	B	C	D	E	F	G	G1	H	I	L	ØM	CH	SW	ØLW	KG	CARBON STEEL	STAINLESS STEEL
																			ITEM CODE	ITEM CODE
GE3 G 1/8	50 MPa	4	35	14,5	71	42,4	11	49	30	48,5	110	91,5	11	G 1/8	24	9	4	0,558	GE3GGT04011A000	GE3GGT04044A000
GE3 G 1/4	50 MPa	6	35	14,5	71	42,4	11	49	30	48,5	110	91,5	15,5	G 1/4	24	9	6	0,536	GE3GGT14011A000	GE3GGT14044A000
GE3 G 3/8	50 MPa	10	40	17,4	73	44,4	11	54,25	35	54,5	110	96,5	15,5	G 3/8	30	9	10	0,695	GE3GGT24011A000	GE3GGT24044A000
GE3 G 1/2	50 MPa	13	43	18	83	48,4	11	57	37	58,5	110	99,5	17	G 1/2	32	9	13	0,825	GE3GGT33011A000	GE3GGT33044A000
GE3 G 3/4	35/40 MPa	20	57	23,4	95	62,5	14	73,5	49	75	180	106,5	21	G 3/4	41	14	20	1,583	GE3GGT44011A000	GE3GGT43044A000
GE3 G 1	35 MPa	25	65	29,5	112	66,5	14	83,5	55	89	180	116,5	24	G 1	50	14	25	2,421	GE3GGT53011A000	GE3GGT53044A000
GE3 G 1 1/4 R	35 MPa	25	65	29,5	120	66,5	14	83,5	55	89	180	116,5	24	G 1 1/4	55	14	25	2,601	GE3GGR63011A000	GE3GGR63044A000
GE3 G 1 1/2 R	35 MPa	25	65	29,5	124	66,5	14	83,5	55	89	180	116,5	24	G 1 1/2	60	14	25	2,756	GE3GGR73011A000	GE3GGR73044A000

GE3 ANSI/ASME B1.20.1 NPT

Standard

TYPE	PN	DN	A	B	C	D	E	F	G	G1	H	I	L	ØM	CH	SW	ØLW	KG	CARBON STEEL	STAINLESS STEEL
																			ITEM CODE	ITEM CODE
GE3 N 1/8	50 MPa	4	35	14,5	71	42,4	11	49	30	48,5	110	91,5	11	N 1/8	24	9	4	0,558	GE3NNT04011A000	GE3NNT04044A000
GE3 N 1/4	50 MPa	6	35	14,5	71	42,4	11	49	30	48,5	110	91,5	17	N 1/4	24	9	6	0,536	GE3NNT14011A000	GE3NNT14044A000
GE3 N 3/8	50 MPa	10	40	17,4	73	44,4	11	54,25	35	54,5	110	96,5	17	N 3/8	30	9	10	0,695	GE3NNT24011A000	GE3NNT24044A000
GE3 N 1/2	50 MPa	13	43	18	83	48,4	11	57	37	58,5	110	99,5	21	N 1/2	32	9	13	0,825	GE3NNT33011A000	GE3NNT33044A000
GE3 N 3/4	35/40 MPa	20	57	23,4	95	62,5	14	73,5	49	75	180	106,5	21	N 3/4	41	14	20	1,583	GE3NNT44011A000	GE3NNT43044A000
GE3 N 1	35 MPa	25	65	29,5	112	66,5	14	83,5	55	89	180	116,5	24	N 1	50	14	25	2,421	GE3NNT53011A000	GE3NNT53044A000
GE3 N 1 1/4 R	35 MPa	25	65	29,5	120	66,5	14	83,5	55	89	180	116,5	24	N 1 1/4	55	14	25	2,601	GE3NNR63011A000	GE3NNR63044A000
GE3 N 1 1/2 R	35 MPa	25	65	29,5	124	66,5	14	83,5	55	89	180	116,5	24	N 1 1/2	60	14	25	2,756	GE3NNR73011A000	GE3NNR73044A000

GE3 SAE J1926-1

Standard

TYPE	PN	DN	A	B	C	D	E	F	G	G1	H	I	L	ØM	CH	SW	ØLW	KG	CARBON STEEL	STAINLESS STEEL
																			ITEM CODE	ITEM CODE
GE3 SAE4	50 MPa	6	35	14,5	71	42,4	11	49	30	48,5	110	91,5	15,5	7/16 UNF	24	9	6	0,536	GE3EEE04011A000	GE3EEE04044A000
GE3 SAE6	50 MPa	10	40	17,4	73	44,4	11	54,25	35	54,5	110	96,5	16	9/16 UNF	30	9	10	0,695	GE3EEE14011A000	GE3EEE14044A000
GE3 SAE8	50 MPa	13	43	18	83	48,4	11	57	37	58,5	110	99,5	17,5	3/4 UNF	32	9	13	0,825	GE3EEE23011A000	GE3EEE23044A000
GE3 SAE12	35/40 MPa	20	57	23,4	95	62,5	14	73,5	49	75	180	106,5	23	1 1/16 UNF	41	14	20	1,583	GE3EEE340011A000	GE3EEE33044A000
GE3 SAE16	35 MPa	25	65	29,5	112	66,5	14	83,5	55	89	180	116,5	23	1 5/16 UNF	50	14	25	2,421	GE3EEE43011A000	GE3EEE43044A000
GE3 SAE20R	35 MPa	25	65	29,5	120	66,5	14	83,5	55	89	180	116,5	23	1 5/8 UNF	55	14	25	2,601	GE3EEE53011A000	GE3EEE53044A000
GE3 SAE24R	35 MPa	25	65	29,5	124	66,5	14	83,5	55	89	180	116,5	23	1 7/8 UNF	60	14	25	2,756	GE3EEE63011A000	GE3EEE63044A000

+ GE3

3-WAY HIGH PRESSURE BALL VALVES

www.gemels.it

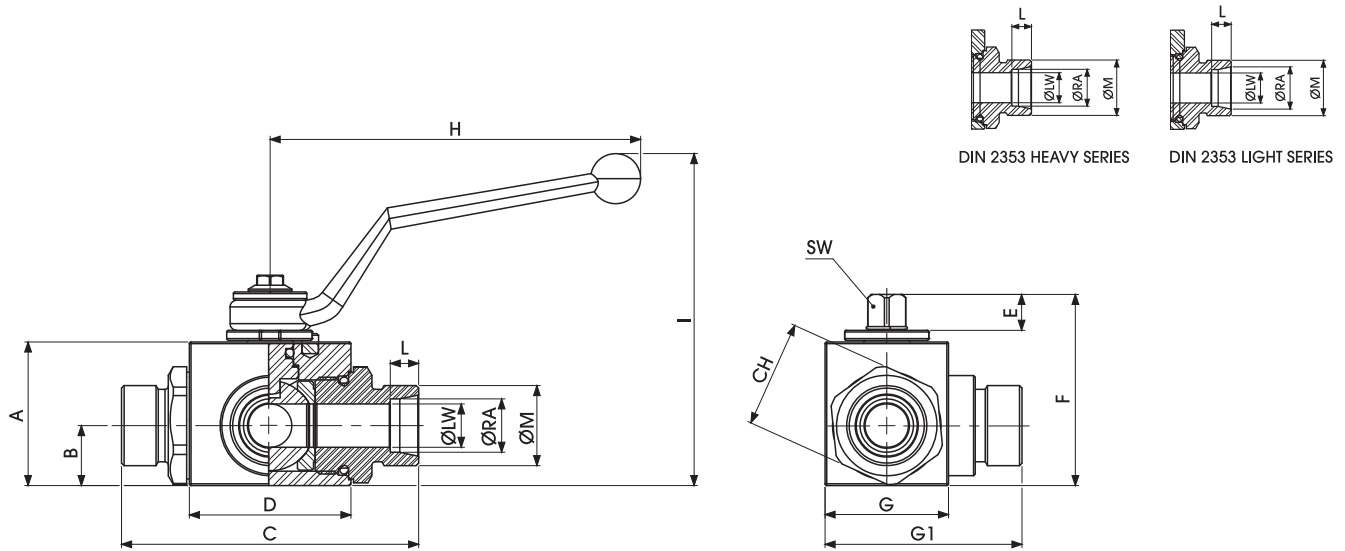

GE3 DIN 2353 HEAVY SERIES

Standard

TYPE	PN	DN	A	B	C	D	E	F	G	G1	H	I	L	ØM	CH	SW	ØLW	ØRA	KG	CARBON STEEL	STAINLESS STEEL
																				ITEM CODE	ITEM CODE
GE3 8S	50 MPa	4	35	14,5	76	42,4	11	49	30	48,5	110	91,5	7	M16x1,5	24	9	4	8	0,53	GE3DDS04011A000	GE3DDS04044A000
GE3 10S	50 MPa	6	35	14,5	76	42,4	11	49	30	48,5	110	91,5	7,5	M18x1,5	24	9	6	10	0,532	GE3DDS14011A000	GE3DDS14044A000
GE3 12S	50 MPa	8	35	14,5	76	42,4	11	49	30	48,5	110	91,5	7,5	M20x1,5	24	9	8	12	0,535	GE3DDRS4011A000	GE3DDRS4044A000
GE3 12S	50 MPa	10	40	17,4	76	44,4	11	54,25	35	54,5	110	96,5	7,5	M20x1,5	30	9	10	12	0,633	GE3DDS24011A000	GE3DDS24044A000
GE3 14S	50 MPa	10	40	17,4	82,5	44,4	11	54,25	35	54,5	110	96,5	8	M22x1,5	30	9	10	14	0,665	GE3DDS34011A000	GE3DDS34044A000
GE3 16S	50 MPa	13	43	18	89	48,4	11	57	37	59	110	99,5	8,5	M24x1,5	32	9	13	16	0,722	GE3DDS43011A000	GE3DDS43044A000
GE3 20S	50 MPa	13	43	18	93	48,4	11	57	37	59	110	99,5	10,5	M30x2	32	9	13	20	0,861	GE3DDS53011A000	GE3DDS53044A000
GE3 25S	35/40 MPa	20	57	23,4	111	62,5	14	73,5	49	75	180	106,5	12	M36x2	41	14	20	25	1,639	GE3DDS64011A000	GE3DDS63044A000
GE3 30S	35 MPa	25	65	29,5	121	66,5	14	83,5	55	89	180	116,5	13	M42x2	50	14	25	30	2,361	GE3DDS73011A000	GE3DDS73044A000
GE3 38S	35 MPa	25	65	29,5	131	66,5	14	83,5	55	89	180	116,5	16	M52x2	55	14	25	38	2,655	GE3DDS83011A000	GE3DDS83044A000

GE3 DIN 2353 LIGHT SERIES

Standard

TYPE	PN	DN	A	B	C	D	E	F	G	G1	H	I	L	ØM	CH	SW	ØLW	ØRA	KG	CARBON STEEL	STAINLESS STEEL
																				ITEM CODE	ITEM CODE
GE3 6L	50 MPa	6	35	14,5	76	42,4	11	49	30	48,5	110	91,5	7	M12x1,5	24	9	6	6	0,53	GE3DDL04011A000	GE3DDL04044A000
GE3 8L	50 MPa	6	35	14,5	76	42,4	11	49	30	48,5	110	91,5	7	M14x1,5	24	9	6	8	0,532	GE3DDL14011A000	GE3DDL14044A000
GE3 10L	50 MPa	6	35	14,5	76	42,4	11	49	30	48,5	110	91,5	7	M16x1,5	24	9	6	10	0,535	GE3DDRL4011A000	GE3DDRL4044A000
GE3 10L	50 MPa	10	40	17,4	76,5	44,4	11	54,25	35	54,5	110	96,5	7	M16x1,5	30	9	10	10	0,633	GE3DDL24011A000	GE3DDL24044A000
GE3 12L	50 MPa	10	40	17,4	79,5	44,4	11	54,25	35	54,5	110	96,5	7	M18x1,5	30	9	10	12	0,665	GE3DDL34011A000	GE3DDL34044A000
GE3 15L	50 MPa	13	43	18	87	48,4	11	57	37	59	110	99,5	7	M22x1,5	32	9	13	15	0,722	GE3DDL43011A000	GE3DDL43044A000
GE3 18L	50 MPa	13	43	18	87	48,4	11	57	37	59	110	99,5	7,5	M26x1,5	32	9	13	18	0,861	GE3DDL53011A000	GE3DDL53044A000
GE3 22L	35/40 MPa	20	57	23,4	110	62,5	14	73,5	49	75	180	106,5	7,5	M30x2	41	14	20	22	1,639	GE3DDL64011A000	GE3DDL63044A000
GE3 28L	35 MPa	25	65	29,5	117	66,5	14	83,5	55	89	180	116,5	7,5	M36x2	50	14	25	28	2,361	GE3DDL73011A000	GE3DDL73044A000
GE3 35L	35 MPa	25	65	29,5	119	66,5	14	83,5	55	89	180	116,5	10,5	M45x2	50	14	25	35	2,361	GE3DDL83011A000	GE3DDL83044A000
GE3 42L	35 MPa	25	65	29,5	119	66,5	14	83,5	55	89	180	116,5	11	M52x2	55	14	25	42	2,456	GE3DDL93011A000	GE3DDL93044A000

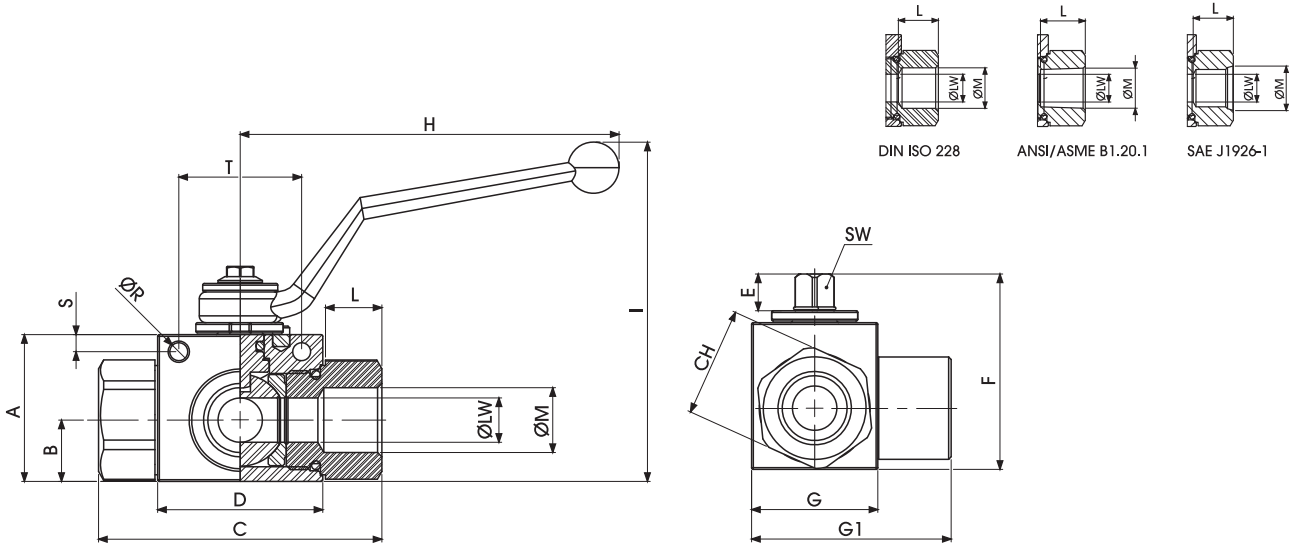

GE3 DIN/ISO 228 BSP

Fixing holes

		CARBON STEEL																		STAINLESS STEEL			
TYPE	PN	DN	A	B	C	D	E	F	G	G1	H	I	L	ØM	CH	ØR	S	T	SW	ØLW	KG	ITEM CODE	ITEM CODE
GE3 G 1/8	50 MPa	4	35	14,5	71	42,4	11	49	30	48,5	110	91,5	11	G 1/8	24	5,25	4,5	34	9	4	0,558	GE3GGT04011AF10	GE3GGT04044AF10
GE3 G 1/4	50 MPa	6	35	14,5	71	42,4	11	49	30	48,5	110	91,5	15,5	G 1/4	24	5,25	4,5	34	9	6	0,536	GE3GGT14011AF10	GE3GGT14044AF10
GE3 G 3/8	50 MPa	10	40	17,4	73	44,4	11	54,25	35	54,5	110	96,5	15,5	G 3/8	30	5,25	4,5	34	9	10	0,695	GE3GGT24011AF10	GE3GGT24044AF10
GE3 G 1/2	50 MPa	13	43	18	83	48,4	11	57	37	58,5	110	99,5	17	G 1/2	32	5,25	5	36	9	13	0,825	GE3GGT33011AF10	GE3GGT33044AF10
GE3 G 3/4	35/40 MPa	20	57	23,4	95	62,5	14	73,5	49	75	180	106,5	21	G 3/4	41	6,25	6	50	14	20	1,583	GE3GGT44011AF10	GE3GGT43044AF10
GE3 G 1	35 MPa	25	65	29,5	112	66,5	14	83,5	55	89	180	116,5	24	G 1	50	6,25	6	50	14	25	2,421	GE3GGT53011AF10	GE3GGT53044AF10
GE3 G 1 1/4 R	35 MPa	25	65	29,5	120	66,5	14	83,5	55	89	180	116,5	24	G 1 1/4	55	6,25	6	50	14	25	2,601	GE3GGR63011AF10	GE3GGR63044AF10
GE3 G 1 1/2 R	35 MPa	25	65	29,5	124	66,5	14	83,5	55	89	180	116,5	24	G 1 1/2	60	6,25	6	50	14	25	2,756	GE3GGR73011AF10	GE3GGR73044AF10

GE3 ANSI/ASME B1.20.1 NPT

Fixing holes

		CARBON STEEL																		STAINLESS STEEL			
TYPE	PN	DN	A	B	C	D	E	F	G	G1	H	I	L	ØM	CH	ØR	S	T	SW	ØLW	KG	ITEM CODE	ITEM CODE
GE3 N 1/8	50 MPa	4	35	14,5	71	42,4	11	49	30	48,5	110	91,5	11	N 1/8	24	5,25	4,5	34	9	4	0,558	GE3NNT04011AF10	GE3NNT04044AF10
GE3 N 1/4	50 MPa	6	35	14,5	71	42,4	11	49	30	48,5	110	91,5	15,5	N 1/4	24	5,25	4,5	34	9	6	0,536	GE3NNT14011AF10	GE3NNT14044AF10
GE3 N 3/8	50 MPa	10	40	17,4	73	44,4	11	54,25	35	54,5	110	96,5	15,5	N 3/8	30	5,25	4,5	34	9	10	0,695	GE3NNT24011AF10	GE3NNT24044AF10
GE3 N 1/2	50 MPa	13	43	18	83	48,4	11	57	37	58,5	110	99,5	17	N 1/2	32	5,25	5	36	9	13	0,825	GE3NNT33011AF10	GE3NNT33044AF10
GE3 N 3/4	35/40 MPa	20	57	23,4	95	62,5	14	73,5	49	75	180	106,5	21	N 3/4	41	6,25	6	50	14	20	1,583	GE3NNT44011AF10	GE3NNT43044AF10
GE3 N 1	35 MPa	25	65	29,5	112	66,5	14	83,5	55	89	180	116,5	24	N 1	50	6,25	6	50	14	25	2,421	GE3NNT53011AF10	GE3NNT53044AF10
GE3 N 1 1/4 R	35 MPa	25	65	29,5	120	66,5	14	83,5	55	89	180	116,5	24	N 1 1/4	55	6,25	6	50	14	25	2,601	GE3NNR63011AF10	GE3NNR63044AF10
GE3 N 1 1/2 R	35 MPa	25	65	29,5	124	66,5	14	83,5	55	89	180	116,5	24	N 1 1/2	60	6,25	6	50	14	25	2,756	GE3NNR73011AF10	GE3NNR73044AF10

GE3 SAE J1926-1

Fixing holes

		CARBON STEEL																		STAINLESS STEEL			
TYPE	PN	DN	A	B	C	D	E	F	G	G1	H	I	L	ØM	CH	ØR	S	T	SW	ØLW	KG	ITEM CODE	ITEM CODE
GE3 SAE4	50 MPa	6	35	14,5	71	42,4	11	49	30	48,5	110	91,5	15,5	7/16 UNF	24	5,25	4,5	34	9	6	0,536	GE3EEE04011AF10	GE3EEE04044AF10
GE3 SAE6	50 MPa	10	40	17,4	73	44,4	11	54,25	35	54,5	110	96,5	16	9/16 UNF	30	5,25	4,5	34	9	10	0,695	GE3EEE14011AF10	GE3EEE14044AF10
GE3 SAE8	50 MPa	13	43	18	83	48,4	11	57	37	58,5	110	99,5	17,5	3/4 UNF	32	5,25	5	36	9	13	0,825	GE3EEE23011AF10	GE3EEE23044AF10
GE3 SAE12	35/40 MPa	20	57	23,4	95	62,5	14	73,5	49	75	180	106,5	23	1 1/16 UNF	41	6,25	6	50	14	20	1,583	GE3EEE34011AF10	GE3EEE33044AF10
GE3 SAE16	35 MPa	25	65	29,5	112	66,5	14	83,5	55	89	180	116,5	23	1 5/16 UNF	50	6,25	6	50	14	25	2,421	GE3EEE43011AF10	GE3EEE43044AF10
GE3 SAE20R	35 MPa	25	65	29,5	120	66,5	14	83,5	55	89	180	116,5	23	1 3/8 UNF	55	6,25	6	50	14	25	2,601	GE3EEE53011AF10	GE3EEE53044AF10
GE3 SAE24R	35 MPa	25	65	29,5	124	66,5	14	83,5	55	89	180	116,5	23	1 7/8 UNF	60	6,25	6	50	14	25	2,756	GE3EEE63011AF10	GE3EEE63044AF10

"The company reserves the right to operate dimensional changes without prior notice".

+ GE3

3-WAY HIGH PRESSURE BALL VALVES

www.gemels.it

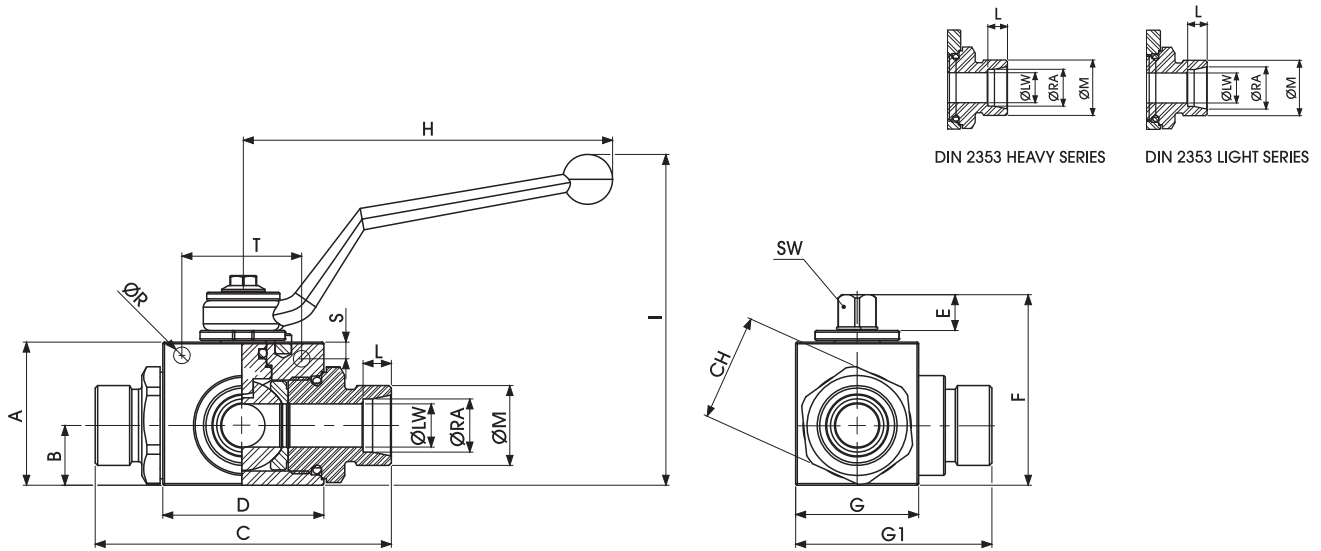

GE3 DIN 2353 HEAVY SERIES

Fixing holes

																				CARBON STEEL	STAINLESS STEEL			
TYPE	PN	DN	A	B	C	D	E	F	G	G1	H	I	L	ØM	CH	ØR	S	T	SW	ØLW	ØRA	KG	ITEM CODE	ITEM CODE
GE3 8S	50 MPa	4	35	14,5	76	42,4	11	49	30	48,5	110	91,5	7	M16x1,5	24	5,25	4,5	34	9	4	8	0,53	GE3DDS04011AF10	GE3DDS04044AF10
GE3 10S	50 MPa	6	35	14,5	76	42,4	11	49	30	48,5	110	91,5	7,5	M18x1,5	24	5,25	4,5	34	9	6	10	0,532	GE3DDS14011AF10	GE3DDS14044AF10
GE3 12S	50 MPa	8	35	14,5	76	42,4	11	49	30	48,5	110	91,5	7,5	M20x1,5	24	5,25	4,5	34	9	8	12	0,535	GE3DDRS4011AF10	GE3DDRS4044AF10
GE3 12S	50 MPa	10	40	17,4	76	44,4	11	54,25	35	54,5	110	96,5	7,5	M20x1,5	30	5,25	4,5	34	9	10	12	0,633	GE3DDS24011AF10	GE3DDS24044AF10
GE3 14S	50 MPa	10	40	17,4	83	44,4	11	54,25	35	54,5	110	96,5	8	M22x1,5	30	5,25	4,5	34	9	10	14	0,665	GE3DDS34011AF10	GE3DDS34044AF10
GE3 16S	50 MPa	13	43	18	89	48,4	11	57	37	59	110	99,5	8,5	M24x1,5	32	5,25	5	36	9	13	16	0,722	GE3DDS43011AF10	GE3DDS43044AF10
GE3 20S	50 MPa	13	43	18	93	48,4	11	57	37	59	110	99,5	10,5	M30x2	32	5,25	5	36	9	13	20	0,861	GE3DDS53011AF10	GE3DDS53044AF10
GE3 25S	35/40 MPa	20	57	23,4	111	62,5	14	73,5	49	75	180	106,5	12	M36x2	41	6,25	6	50	14	20	25	1,639	GE3DDS64011AF10	GE3DDS63044AF10
GE3 30S	35 MPa	25	65	29,5	121	66,5	14	83,5	55	89	180	116,5	13	M42x2	50	6,25	6	50	14	25	30	2,361	GE3DDS73011AF10	GE3DDS73044AF10
GE3 38S	35 MPa	25	65	29,5	131	66,5	14	83,5	55	89	180	116,5	16	M52x2	55	6,25	6	50	14	25	38	2,655	GE3DDS83011AF10	GE3DDS83044AF10

GE3 DIN 2353 LIGHT SERIES

Fixing holes

																				CARBON STEEL	STAINLESS STEEL			
TYPE	PN	DN	A	B	C	D	E	F	G	G1	H	I	L	ØM	CH	ØR	S	T	SW	ØLW	ØRA	KG	ITEM CODE	ITEM CODE
GE3 6L	50 MPa	6	35	14,5	76	42,4	11	49	30	48,5	110	91,5	7	M12x1,5	24	5,25	4,5	34	9	6	6	0,53	GE3DDL04011AF10	GE3DDL04044AF10
GE3 8L	50 MPa	6	35	14,5	76	42,4	11	49	30	48,5	110	91,5	7	M14x1,5	24	5,25	4,5	34	9	6	8	0,532	GE3DDL14011AF10	GE3DDL14044AF10
GE3 10L	50 MPa	6	35	14,5	76	42,4	11	49	30	48,5	110	91,5	7	M16x1,5	24	5,25	4,5	34	9	6	10	0,535	GE3DDR14011AF10	GE3DDR14044AF10
GE3 10L	50 MPa	10	40	17,4	77	44,4	11	54,25	35	54,5	110	96,5	7	M16x1,5	30	5,25	4,5	34	9	10	10	0,633	GE3DDL24011AF10	GE3DDL24044AF10
GE3 12L	50 MPa	10	40	17,4	80	44,4	11	54,25	35	54,5	110	96,5	7	M18x1,5	30	5,25	4,5	34	9	10	12	0,665	GE3DDL34011AF10	GE3DDL34044AF10
GE3 15L	50 MPa	13	43	18	87	48,4	11	57	37	59	110	99,5	7	M22x1,5	32	5,25	5	36	9	13	15	0,722	GE3DDL43011AF10	GE3DDL43044AF10
GE3 18L	50 MPa	13	43	18	87	48,4	11	57	37	59	110	99,5	7,5	M26x1,5	32	5,25	5	36	9	13	18	0,861	GE3DDL53011AF10	GE3DDL53044AF10
GE3 22L	35/40 MPa	20	57	23,4	110	62,5	14	73,5	49	75	180	106,5	7,5	M30x2	41	6,25	6	50	14	20	22	1,639	GE3DDL64011AF10	GE3DDL63044AF10
GE3 28L	35 MPa	25	65	29,5	117	66,5	14	83,5	55	89	180	116,5	7,5	M36x2	50	6,25	6	50	14	25	28	2,361	GE3DDL73011AF10	GE3DDL73044AF10
GE3 35L	35 MPa	25	65	29,5	119	66,5	14	83,5	55	89	180	116,5	10,5	M45x2	50	6,25	6	50	14	25	35	2,361	GE3DDL83011AF10	GE3DDL83044AF10
GE3 42L	35 MPa	25	65	29,5	119	66,5	14	83,5	55	89	180	116,5	11	M52x2	55	6,25	6	50	14	25	42	2,456	GE3DDL93011AF10	GE3DDL93044AF10



3-WAY HIGH PRESSURE BALL VALVES

Specialist in Ball Valves

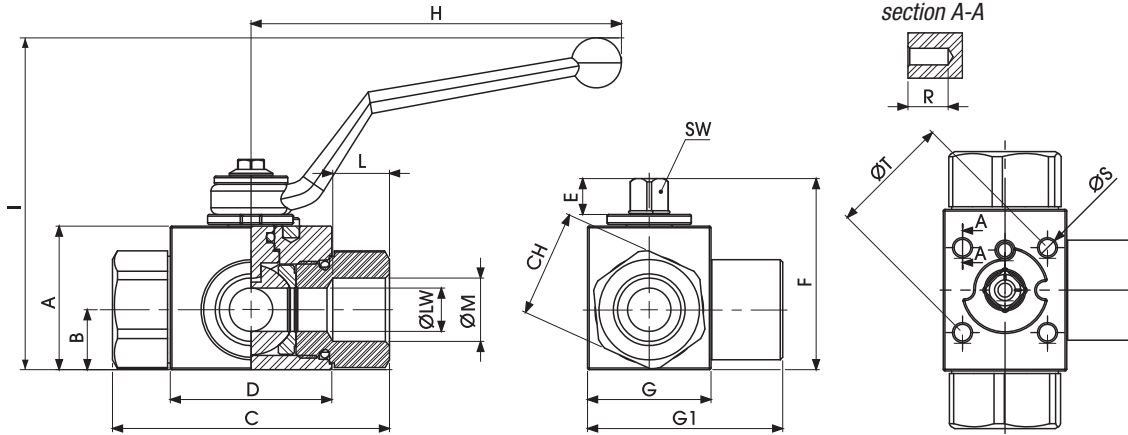
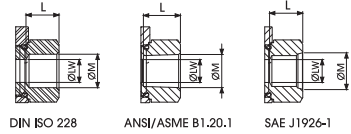

GE3 DIN/ISO 228 BSP

Fixing holes DIN/ISO5211

																				CARBON STEEL	STAINLESS STEEL			
TYPE	PN	DN	A	B	C	D	E	F	G	G1	H	I	L	ØM	CH	R	ØS	ØT	ISO5211	SW	LW	KG	ITEM CODE	ITEM CODE
GE3 G 1/8	50 MPa	4	35	14,5	71	42,4	11	49	30	48,5	110	91,5	11	G 1/8	24	9,5	M4	35	F03	9	4	0,558	GE3GGT04011AF50	GE3GGT04044AF50
GE3 G 1/4	50 MPa	6	35	14,5	71	42,4	11	49	30	48,5	110	91,5	15,5	G 1/4	24	9,5	M4	35	F03	9	6	0,536	GE3GGT14011AF50	GE3GGT14044AF50
GE3 G 3/8	50 MPa	10	40	17,4	73	44,4	11	54,25	35	54,5	110	96,5	15,5	G 3/8	30	9,5	M5	36	F03	9	10	0,695	GE3GGT24011AF50	GE3GGT24044AF50
GE3 G 1/2	50 MPa	13	43	18	83	48,4	11	57	37	58,5	110	99,5	17	G 1/2	32	9,5	M5	36	F03	9	13	0,825	GE3GGT33011AF50	GE3GGT33044AF50
GE3 G 3/4	35/40 MPa	20	57	23,4	95	62,5	14	73,5	49	75	180	106,5	21	G 3/4	41	15	M6	50	F05	14	20	1,583	GE3GGT44011AF50	GE3GGT43044AF50
GE3 G 1	35 MPa	25	65	29,5	112	66,5	14	83,5	55	89	180	116,5	24	G 1	50	15	M6	50	F05	14	25	2,421	GE3GGT53011AF50	GE3GGT53044AF50
GE3 G 1 1/4 R	35 MPa	25	65	29,5	120	66,5	14	83,5	55	89	180	116,5	24	G 1 1/4	55	15	M6	50	F05	14	25	2,601	GE3GGR63011AF50	GE3GGR63044AF50
GE3 G 1 1/2 R	35 MPa	25	65	29,5	124	66,5	14	83,5	55	89	180	116,5	24	G 1 1/2	60	15	M6	50	F05	14	25	2,756	GE3GGR73011AF50	GE3GGR73044AF50

GE3 ANSI/ASME B1.20.1 NPT

Fixing holes DIN/ISO5211

																				CARBON STEEL	STAINLESS STEEL			
TYPE	PN	DN	A	B	C	D	E	F	G	G1	H	I	L	ØM	CH	R	ØS	ØT	ISO5211	SW	LW	KG	ITEM CODE	ITEM CODE
GE3 N 1/8	50 MPa	4	35	14,5	71	42,4	11	49	30	48,5	110	91,5	11	N 1/8	24	9	M4	35	F03	9	4	0,558	GE3NNT04011AF50	GE3NNT04044AF50
GE3 N 1/4	50 MPa	6	35	14,5	71	42,4	11	49	30	48,5	110	91,5	17	N 1/4	24	9	M4	35	F03	9	6	0,536	GE3NNT14011AF50	GE3NNT14044AF50
GE3 N 3/8	50 MPa	10	40	17,4	73	44,4	11	54,25	35	54,5	110	96,5	17	N 3/8	30	9	M5	36	F03	9	10	0,695	GE3NNT24011AF50	GE3NNT24044AF50
GE3 N 1/2	50 MPa	13	43	18	83	48,4	11	57	37	58,5	110	99,5	21	N 1/2	32	9	M5	36	F03	9	13	0,825	GE3NNT33011AF50	GE3NNT33044AF50
GE3 N 3/4	35/40 MPa	20	57	23,4	95	62,5	14	73,5	49	75	180	106,5	21	N 3/4	41	15	M6	50	F05	14	20	1,583	GE3NNT44011AF50	GE3NNT43044AF50
GE3 N 1	35 MPa	25	65	29,5	112	66,5	14	83,5	55	89	180	116,5	24	N 1	50	15	M6	50	F05	14	25	2,421	GE3NNT53011AF50	GE3NNT53044AF50
GE3 N 1 1/4 R	35 MPa	25	65	29,5	120	66,5	14	83,5	55	89	180	116,5	24	N 1 1/4	55	15	M6	50	F05	14	25	2,601	GE3NNR63011AF50	GE3NNR63044AF50
GE3 N 1 1/2 R	35 MPa	25	65	29,5	124	66,5	14	83,5	55	89	180	116,5	24	N 1 1/2	60	15	M6	50	F05	14	25	2,756	GE3NNR73011AF50	GE3NNR73044AF50

GE3 SAE J1926-1

Fixing holes DIN/ISO5211

																				CARBON STEEL	STAINLESS STEEL			
TYPE	PN	DN	A	B	C	D	E	F	G	G1	H	I	L	ØM	CH	R	ØS	ØT	ISO5211	SW	LW	KG	ITEM CODE	ITEM CODE
GE3 SAE4	50 MPa	6	35	14,5	71	42,4	11	49	30	48,5	110	91,5	15,5	7/16 UNF	24	9	M4	35	F03	9	6	0,536	GE3EEE04011AF50	GE3EEE04044AF50
GE3 SAE6	50 MPa	10	40	17,4	73	44,4	11	54,25	35	54,5	110	96,5	16	9/16 UNF	30	9	M5	36	F03	9	10	0,695	GE3EEE14011AF50	GE3EEE14044AF50
GE3 SAE8	50 MPa	13	43	18	83	48,4	11	57	37	58,5	110	99,5	17,5	3/4 UNF	32	9	M5	36	F03	9	13	0,825	GE3EEE23011AF50	GE3EEE23044AF50
GE3 SAE12	35/40 MPa	20	57	23,4	95	62,5	14	73,5	49	75	180	106,5	23	1 1/16 UNF	41	15	M6	50	F05	14	20	1,583	GE3EEE34011AF50	GE3EEE33044AF50
GE3 SAE16	35 MPa	25	65	29,5	112	66,5	14	83,5	55	89	180	116,5	23	1 5/16 UNF	50	15	M6	50	F05	14	25	2,421	GE3EEE43011AF50	GE3EEE43044AF50
GE3 SAE20R	35 MPa	25	65	29,5	120	66,5	14	83,5	55	89	180	116,5	23	1 5/8 UNF	55	15	M6	50	F05	14	25	2,601	GE3EEE53011AF50	GE3EEE53044AF50
GE3 SAE24R	35 MPa	25	65	29,5	124	66,5	14	83,5	55	89	180	116,5	23	1 7/8 UNF	60	15	M6	50	F05	14	25	2,756	GE3EEE63011AF50	GE3EEE63044AF50

"The company reserves the right to operate dimensional changes without prior notice".

+ GE3

3-WAY HIGH PRESSURE BALL VALVES

www.gemels.it

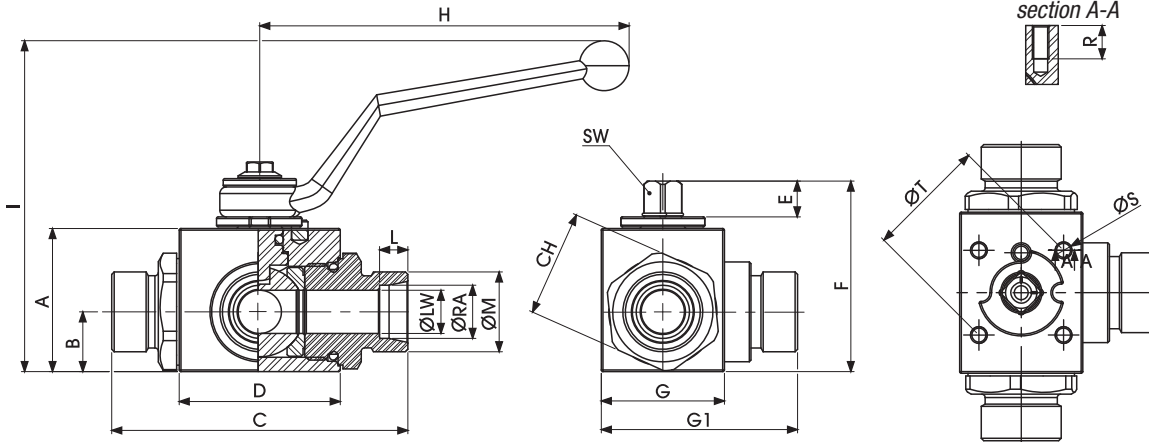
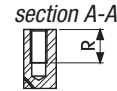
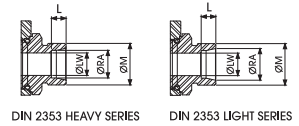

GE3 DIN 2353 HEAVY SERIES

Fixing holes DIN/ISO5211

																		CARBON STEEL		STAINLESS STEEL					
TYPE	PN	DN	A	B	C	D	E	F	G	G1	H	I	L	ØM	CH	R	ØS	ØT	ISO5211	SW	ØLW	ØRA	KG	ITEM CODE	ITEM CODE
GE3 8S	50 MPa	4	35	14,5	76	42,4	11	49	30	48,5	110	91,5	7	M16x1,5	24	9	M4	35	F03	9	4	8	0,53	GE3DDS04011AF50	GE3DDS04044AF50
GE3 10S	50 MPa	6	35	14,5	76	42,4	11	49	30	48,5	110	91,5	7,5	M18x1,5	24	9	M4	35	F03	9	6	10	0,532	GE3DDS14011AF50	GE3DDS14044AF50
GE3 12S	50 MPa	8	35	14,5	76	42,4	11	49	30	48,5	110	91,5	7,5	M20x1,5	24	9	M4	35	F03	9	8	12	0,535	GE3DDRS4011AF50	GE3DDRS4044AF50
GE3 12S	50 MPa	10	40	17,4	76	44,4	11	54,25	35	54,5	110	96,5	7,5	M20x1,5	30	9	M5	36	F03	9	10	12	0,633	GE3DDS24011AF50	GE3DDS24044AF50
GE3 14S	50 MPa	10	40	17,4	83	44,4	11	54,25	35	54,5	110	96,5	8	M22x1,5	30	9	M5	36	F03	9	10	14	0,665	GE3DDS34011AF50	GE3DDS34044AF50
GE3 16S	50 MPa	13	43	18	89	48,4	11	57	37	59	110	99,5	8,5	M24x1,5	32	9	M5	36	F03	9	13	16	0,722	GE3DDS43011AF50	GE3DDS43044AF50
GE3 20S	50 MPa	13	43	18	93	48,4	11	57	37	59	110	99,5	10,5	M30x2	32	9	M5	36	F03	9	13	20	0,861	GE3DDS53011AF50	GE3DDS53044AF50
GE3 25S	35/40 MPa	20	57	23,4	111	62,5	14	73,5	49	75	180	106,5	12	M36x2	41	15	M6	50	F05	14	20	25	1,639	GE3DDS64011AF50	GE3DDS63044AF50
GE3 30S	35 MPa	25	65	29,5	121	66,5	14	83,5	55	89	180	116,5	13	M42x2	50	15	M6	50	F05	14	25	30	2,361	GE3DDS73011AF50	GE3DDS73044AF50
GE3 38S	35 MPa	25	65	29,5	131	66,5	14	83,5	55	89	180	116,5	16	M52x2	55	15	M6	50	F05	14	25	38	2,655	GE3DDS83011AF50	GE3DDS83044AF50

GE3 DIN 2353 LIGHT SERIES

Fixing holes DIN/ISO5211

																		CARBON STEEL		STAINLESS STEEL					
TYPE	PN	DN	A	B	C	D	E	F	G	G1	H	I	L	ØM	CH	R	ØS	ØT	ISO5211	SW	ØLW	ØRA	KG	ITEM CODE	ITEM CODE
GE3 6L	50 MPa	6	35	14,5	76	42,4	11	49	30	48,5	110	91,5	7	M12x1,5	24	9	M4	35	F03	9	6	6	0,53	GE3DDL04011AF50	GE3DDL04044AF50
GE3 8L	50 MPa	6	35	14,5	76	42,4	11	49	30	48,5	110	91,5	7	M14x1,5	24	9	M4	35	F03	9	6	8	0,532	GE3DDL14011AF50	GE3DDL14044AF50
GE3 10L	50 MPa	6	35	14,5	76	42,4	11	49	30	48,5	110	91,5	7	M16x1,5	24	9	M4	35	F03	9	6	10	0,535	GE3DRL4011AF50	GE3DRL4044AF50
GE3 10L	50 MPa	10	40	17,4	77	44,4	11	54,25	35	54,5	110	96,5	7	M16x1,5	30	9	M5	36	F03	9	10	10	0,633	GE3DDL24011AF50	GE3DDL24044AF50
GE3 12L	50 MPa	10	40	17,4	80	44,4	11	54,25	35	54,5	110	96,5	7	M18x1,5	30	9	M5	36	F03	9	10	12	0,665	GE3DDL34011AF50	GE3DDL34044AF50
GE3 15L	50 MPa	13	43	18	87	48,4	11	57	37	59	110	99,5	7	M22x1,5	32	9	M5	36	F03	9	13	15	0,722	GE3DDL43011AF50	GE3DDL43044AF50
GE3 18L	50 MPa	13	43	18	87	48,4	11	57	37	59	110	99,5	7,5	M26x1,5	32	9	M5	36	F03	9	13	18	0,861	GE3DDL53011AF50	GE3DDL53044AF50
GE3 22L	35/40 MPa	20	57	23,4	110	62,5	14	73,5	49	75	180	106,5	7,5	M30x2	41	15	M6	50	F05	14	20	22	1,639	GE3DDL64011AF50	GE3DDL63044AF50
GE3 28L	35 MPa	25	65	29,5	117	66,5	14	83,5	55	89	180	116,5	7,5	M36x2	50	15	M6	50	F05	14	25	28	2,361	GE3DDL73011AF50	GE3DDL73044AF50
GE3 35L	35 MPa	25	65	29,5	119	66,5	14	83,5	55	89	180	116,5	10,5	M45x2	50	15	M6	50	F05	14	25	35	2,361	GE3DDL83011AF50	GE3DDL83044AF50
GE3 42L	35 MPa	25	65	29,5	119	66,5	14	83,5	55	89	180	116,5	11	M52x2	55	15	M6	50	F05	14	25	42	2,456	GE3DDL93011AF50	GE3DDL93044AF50

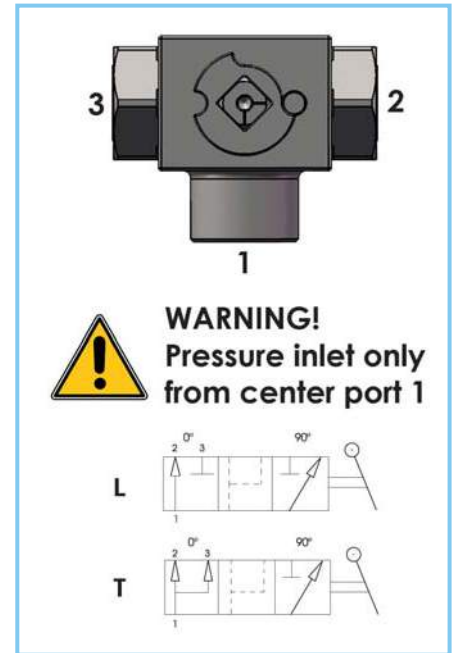
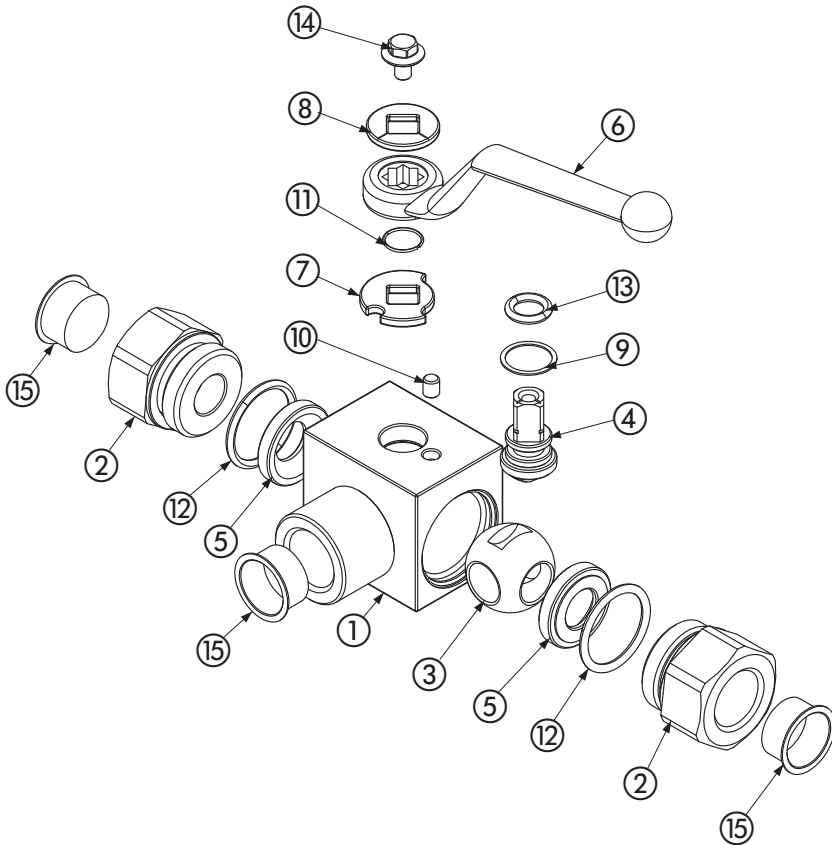

Carbon steel			
Pos	Description	Material	Q.tà
1	Body	1,0737	1
2	Adapter	1,0737	2
3	Ball	1,0737	1
4	Stem	1,0737	1
5	Ball seat	POM	2
6	Handle	ZINC	1
7	Washer	1,0116	1
8	Washer	1,0116	1
9	Stem ring	POM	1
10	Spine	1,0737	1
11	Seeger	1,4301	1
12	Adapter o-ring	NBR	2
13	Stem o-ring	NBR	1
14	Screw	Din 6921 8.8	1
15	Caps	PVC	3

Stainless steel			
Pos	Description	Material	Q.tà
1	Body	1,4404	1
2	Adapter	1,4404	2
3	Ball	1,4404	1
4	Stem	1,4404	1
5	Ball seat	POM	2
6	Handle	ZINC	1
7	Washer	1,4301	1
8	Washer	1,4301	1
9	Stem ring	POM	1
10	Spine	1,4301	1
11	Seeger	1,4301	1
12	Adapter o-ring	NBR	2
13	Stem o-ring	NBR	1
14	Screw	Din 6921 A2	1
15	Caps	PVC	3

For further special requests please consult our technical/commercial service

- On request**
- Reduced bore
 - O-Ring in FKM, EPDM, HNBR, KALREZ
 - Seals in PTFE, PEEK, PA612, GEMPTFE, METAL TO METAL
 - Special threads
 - Stem in stainless steel 1,4404
 - Ball in stainless steel 1,4404
 - Pressure class up to PN40 MPa
 - Pneumatic and electrical actuator
 - Security block
 - Locking device

- On request**
- Reduced bore
 - O-Ring in FKM, EPDM, HNBR, KALREZ
 - Seals in PTFE, PEEK, PA612, GEMPTFE, METAL TO METAL
 - Special threads
 - Pressure class up to PN40 MPa
 - Pneumatic and electrical actuator
 - Security block
 - Locking device

+ GE5

3-WAY HIGH PRESSURE BALL VALVES

SMALLER DESIGN

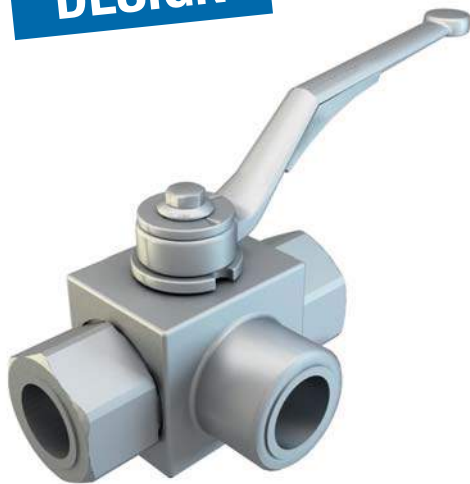

CARBON STEEL

- Type: ball valve GE 3 way
- Body: block
- Material: 1,0737
- Ball seats: from DN6 up to DN13
- O-Rings: NBR, FKM, EPDM, MVQ
- Operating pressure: 500 Bar depending on valve size and seal materials selected
- Temp range: -20°C to +100°C depending on seal material selected

GE5	G 3/8			DN10	1	1	1	1	A	B
Type and way of valve	GAS DIN/ISO 228 BSP	NPT ANSI/ASME B1.20.1	SAE J1926-1	Nominal dimension	Body material	Adapter material	Stem material	Ball material	Ball seat material	Adapter and stem seal material
GE3 3-way	G 1/4	N 1/4	SAE4	DN6	1 1,0737	1 1,0737	1 1,0737	1 1,0737	A POM	B NBR
	G 3/8	N 3/8	SAE6	DN10						
	G 1/2	N 1/2	SAE8	DN13						



3-WAY HIGH PRESSURE BALL VALVES

Specialist in Ball Valves

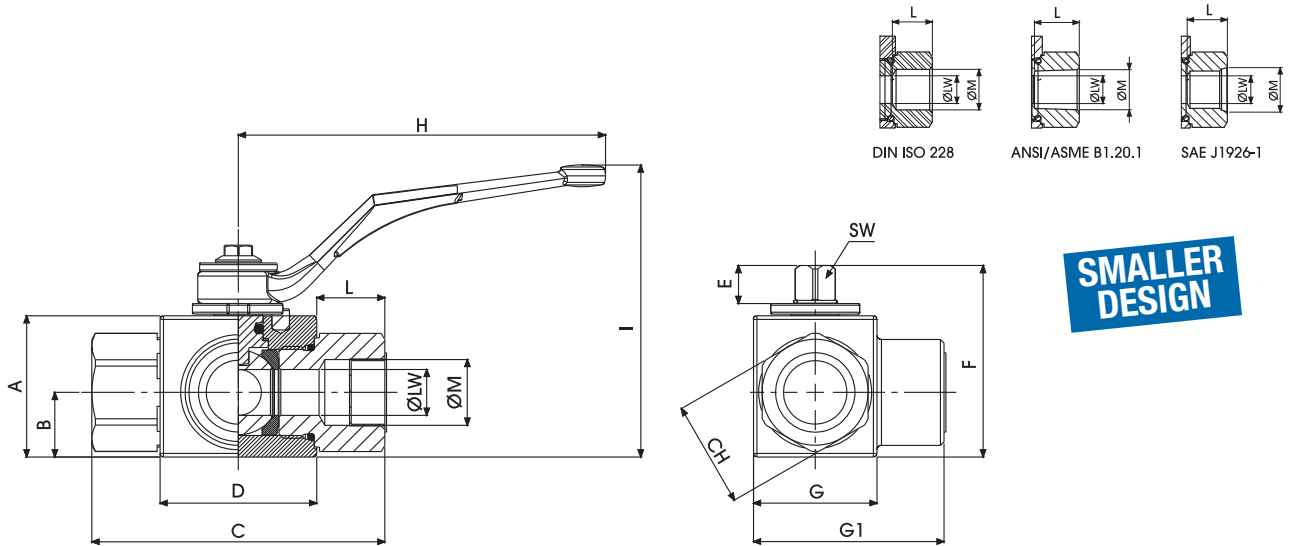

GE5 DIN/ISO 228 BSP

Standard

CARBON STEEL

TYPE	PN	DN	A	B	C	D	E	F	G	G1	H	I	L	ØM	CH	SW	ØLW	KG	ITEM CODE
GE5 G 1/4	50 MPa	6	33	14,3	69	39,4	10,8	47,3	26	42	104	76	14,8	G 1/4	22	9	6	0,411	GE5GGT15011A000
GE5 G 3/8	50 MPa	10	35	15	71	41,8	10,8	49,3	30	46	104	78	14,6	G 3/8	27	9	10	0,512	GE5GGT25011A000
GE5 G 1/2	50 MPa	13	40	18,3	83	44,4	10,8	54,3	35	54	104	83	19,3	G 1/2	30	9	13	0,693	GE5GGT35011A000

GE5 ANSI/ASME B1.20.1 NPT

Standard

CARBON STEEL

TYPE	PN	DN	A	B	C	D	E	F	G	G1	H	I	L	ØM	CH	SW	ØLW	KG	ITEM CODE
GE5 N 1/4	50 MPa	6	33	14,3	69	39,4	10,8	47,3	26	42	104	76	14,8	N 1/4	24	9	6	0,411	GE5NNT15011A000
GE5 N 3/8	50 MPa	10	35	15	71	41,8	10,8	49,3	30	46	104	78	14,6	N 3/8	30	9	10	0,512	GE5NNT25011A000
GE5 N 1/2	50 MPa	13	40	18,3	83	44,4	10,8	54,3	35	54	104	83	19,3	N 1/2	32	9	13	0,693	GE5NNT35011A000

GE5 SAE J1926-1

Standard

CARBON STEEL

TYPE	PN	DN	A	B	C	D	E	F	G	G1	H	I	L	ØM	CH	SW	ØLW	KG	ITEM CODE
GE5 SAE4	50 MPa	6	33	14,3	69	39,4	10,8	47,3	26	42	104	76	14,8	7/16 UNF	24	9	6	0,411	GE5EEE05011A000
GE5 SAE6	50 MPa	10	35	15	71	41,8	10,8	49,3	30	46	104	78	14,6	9/16 UNF	30	9	10	0,512	GE5EEE15011A000
GE5 SAE8	50 MPa	13	40	18,3	83	44,4	10,8	54,3	35	54	104	83	19,3	3/4 UNF	32	9	13	0,693	GE5EEE25011A000

+ GE5

3-WAY HIGH PRESSURE BALL VALVES

www.gemels.it

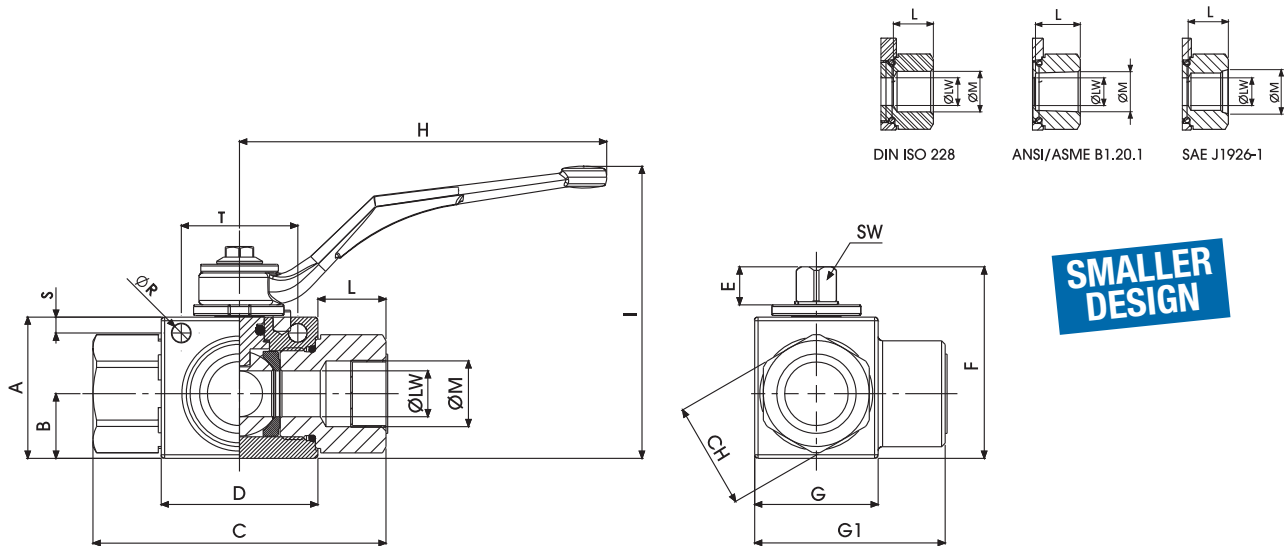

GE5 DIN/ISO 228 BSP

Fixing holes

CARBON STEEL

TYPE	PN	DN	A	B	C	D	E	F	G	G1	H	I	L	ØM	CH	ØR	S	T	SW	ØLW	KG	ITEM CODE
GE5 G 1/4	50 MPa	6	33	14,3	69	39,4	10,8	47,3	26	42	104	76	14,8	G 1/4	22	5,25	4,5	33	9	6	0,411	GE5GGT15011AF10
GE5 G 3/8	50 MPa	10	35	15	71	41,8	10,8	49,3	30	46	104	78	14,6	G 3/8	27	5,25	4,5	33	9	10	0,512	GE5GGT25011AF10
GE5 G 1/2	50 MPa	13	40	18,3	83	44,4	10,8	54,3	35	54	104	83	19,3	G 1/2	30	5,25	4,5	33	9	13	0,693	GE5GGT35011AF10

GE5 ANSI/ASME B1.20.1 NPT

Fixing holes

CARBON STEEL

TYPE	PN	DN	A	B	C	D	E	F	G	G1	H	I	L	ØM	CH	ØR	S	T	SW	ØLW	KG	ITEM CODE
GE5 N 1/4	50 MPa	6	33	14,3	69	39,4	10,8	47,3	26	42	104	76	14,8	N 1/4	22	5,25	4,5	33	9	6	0,411	GE5NNT15011AF10
GE5 N 3/8	50 MPa	10	35	15	71	41,8	10,8	49,3	30	46	104	78	14,6	N 3/8	27	5,25	4,5	33	9	10	0,512	GE5NNT25011AF10
GE5 N 1/2	50 MPa	13	40	18,3	83	44,4	10,8	54,3	35	54	104	83	19,3	N 1/2	30	5,25	4,5	33	9	13	0,693	GE5NNT35011AF10

GE5 SAE J1926-1

Fixing holes

CARBON STEEL

TYPE	PN	DN	A	B	C	D	E	F	G	G1	H	I	L	ØM	CH	ØR	S	T	SW	ØLW	KG	ITEM CODE
GE5 SAE4	50 MPa	6	33	14,3	69	39,4	10,8	47,3	26	42	104	76	14,8	7/16 UNF	22	5,25	4,5	33	9	6	0,411	GE5EEE05011AF10
GE5 SAE6	50 MPa	10	35	15	71	41,8	10,8	49,3	30	46	104	78	14,6	9/16 UNF	27	5,25	4,5	33	9	10	0,512	GE5EEE15011AF10
GE5 SAE8	50 MPa	13	40	18,3	83	44,4	10,8	54,3	35	54	104	83	19,3	3/4 UNF	30	5,25	4,5	33	9	13	0,693	GE5EEE25011AF10

SMALLER DESIGN

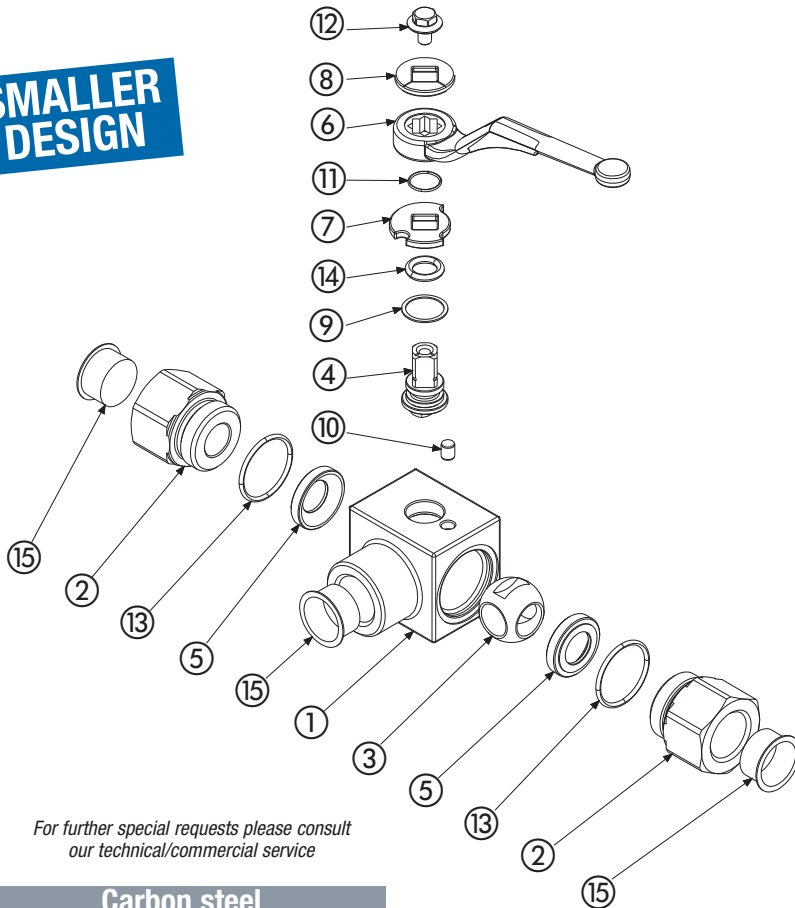

For further special requests please consult our technical/commercial service

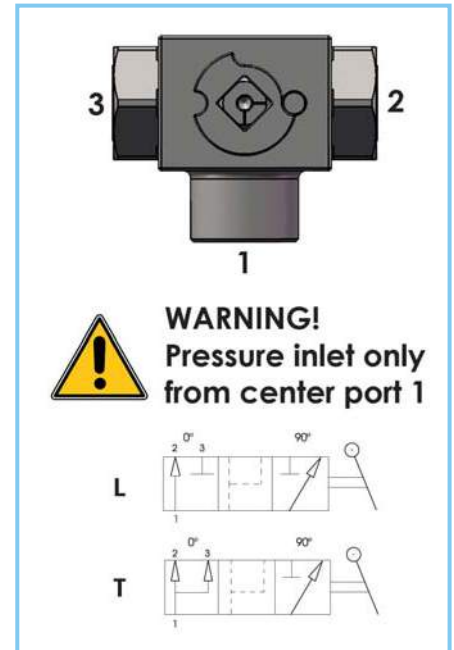

Carbon steel			
Pos	Description	Material	Q.tà
1	Body	1,0737	1
2	Adapter	1,0737	2
3	Ball	1,0737	1
4	Stem	1,0737	1
5	Ball seat	POM	2
6	Handle	ZINC	1
7	Washer	1,0116	1
8	Washer	1,0116	1
9	Stem ring	POM	1
10	Spine	1,0737	1
11	Seeger	1,4301	1
12	Adapter o-ring	NBR	2
13	Stem o-ring	NBR	1
14	Screw	Din 6921 8.8	1
15	Caps	PVC	3

- On request**
- Reduced bore
 - O-Ring in FKM, EPDM, HNBR, KALREZ
 - Seals in PTFE, PEEK, PA612, GEMPTFE, METAL TO METAL
 - Special threads
 - Stem in stainless steel 1,4404
 - Ball in stainless steel 1,4404
 - Pressure class up to PN50 MPa
 - Pneumatic and electrical actuator
 - Security block
 - Locking device

+ GE3K

3-WAY HIGH PRESSURE BALL VALVES



CARBON STEEL

- Type: ball valve GE 3 way
- Body: block
- Material: 1,0737
- Ball seats: from DN4 up to DN25
- O-Rings: NBR
- Operating pressure: 500 Bar depending on valve size and seal materials selected
- Temp range: -20°C to +100°C depending on seal material selected

GE3K	G 1/2			DN13	2	1	1	1	A	B
Type and way of valve	GAS	NPT	SAE	Nominal dimension	Body material	Adapter material	Stem material	Ball material	Ball seat material	Adapter and stem seal material
GE3 3-way	DIN/ISO 228 BSP	ANSI/ASME B1.20.1	J1926-1							
	G 1/8	N 1/8	SAE4	DN4	2 1,0737	1 1,0737	1 1,0737	1 1,0737	A POM	B NBR
	G 1/4	N 1/4	SAE6	DN6						
	G 3/8	N 3/8	SAE8	DN10						
	G 1/2	N 1/2	SAE12	DN13						
	G 3/4	N 3/4	SAE16	DN20						
	G 1	N 1	SAE20R	DN25						
	G 1 1/4 R	N 1 1/4 R	SAE24R							
	G 1 1/2 R	N 1 1/2 R								

STAINLESS STEEL

- Type: ball valve GE 3 way
- Body: block
- Material: 1,4404
- Ball seats: from DN4 up to DN25
- O-Rings: NBR
- Operating pressure: 500 Bar depending on valve size and seal materials selected
- Temp range: -30°C to +100°C different temperatures on request

GE3K	G 1/2			DN13	4	4	4	4	A	B
Type and way of valve	GAS	NPT	SAE	Nominal dimension	Body material	Adapter material	Stem material	Ball material	Ball seat material	Adapter and stem seal material
GE3 3-way	DIN/ISO 228 BSP	ANSI/ASME B1.20.1	J1926-1							
	G 1/8	N 1/8	SAE4	DN4	4 1,4404	4 1,4404	4 1,4404	4 1,4404	A POM	B NBR
	G 1/4	N 1/4	SAE6	DN6						
	G 3/8	N 3/8	SAE8	DN10						
	G 1/2	N 1/2	SAE12	DN13						
	G 3/4	N 3/4	SAE16	DN20						
	G 1	N 1	SAE20R	DN25						
	G 1 1/4 R	N 1 1/4 R	SAE24R							
	G 1 1/2 R	N 1 1/2 R								

"The company reserves the right to operate dimensional changes without prior notice".

+ GE3K 3-WAY HIGH PRESSURE BALL VALVES

Specialist in Ball Valves

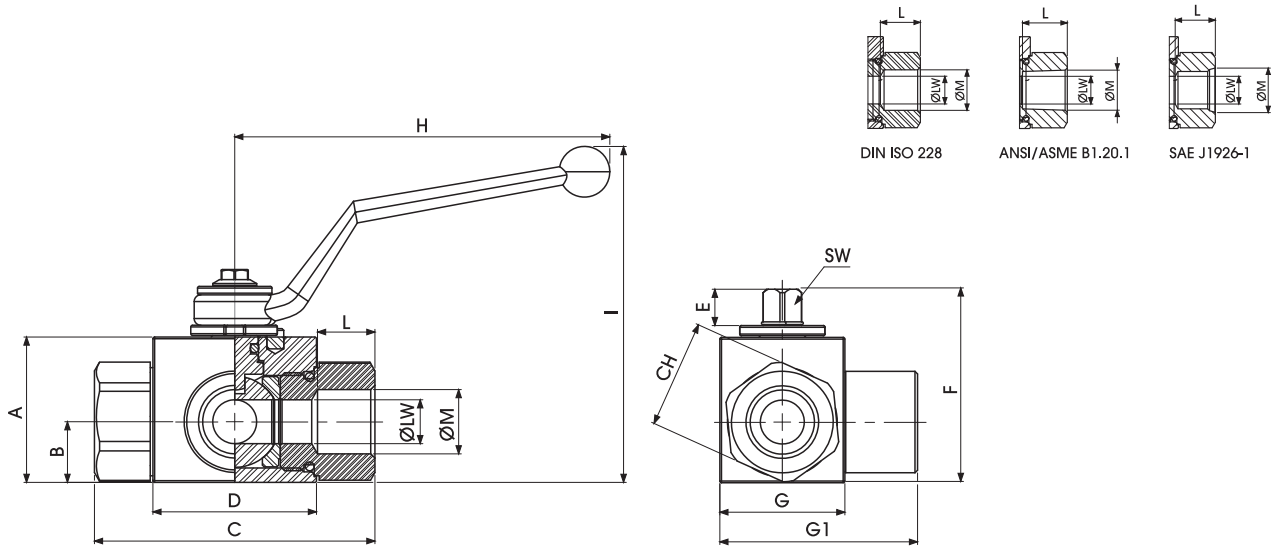

GE3K DIN/ISO 228 BSP

Standard

TYPE	PN	DN	A	B	C	D	E	F	G	G1	H	I	L	ØM	CH	SW	ØLW	KG	CARBON STEEL	STAINLESS STEEL
																			ITEM CODE	ITEM CODE
GE3K G 1/8	50 MPa	4	35	14,5	71	42,4	11	49	30	48,5	110	91,5	11	G 1/8	24	9	4	0,558	GK3GGT04011A000	GK3GGT04044A000
GE3K G 1/4	50 MPa	6	35	14,5	71	42,4	11	49	30	48,5	110	91,5	15,5	G 1/4	24	9	6	0,536	GK3GGT14011A000	GK3GGT14044A000
GE3K G 3/8	50 MPa	10	40	17,4	73	44,4	11	54,25	35	54,5	110	96,5	15,5	G 3/8	30	9	10	0,695	GK3GGT24011A000	GK3GGT24044A000
GE3K G 1/2	50 MPa	13	43	18	83	48,4	11	57	37	58,5	110	99,5	17	G 1/2	32	9	13	0,825	GK3GGT33011A000	GK3GGT33044A000
GE3K G 3/4	35/40 MPa	20	57	23,4	95	62,5	14	73,5	49	75	180	106,5	21	G 3/4	41	14	20	1,583	GK3GGT44011A000	GK3GGT43044A000
GE3K G 1	35 MPa	25	65	29,5	105	66,5	14	83,5	55	89	180	116,5	24	G 1	50	14	25	2,421	GK3GGT53011A000	GK3GGT53044A000
GE3K G 1 1/4 R	35 MPa	25	65	29,5	120	66,5	14	83,5	55	89	180	116,5	24	G 1 1/4	55	14	25	2,601	GK3GGR63011A000	GK3GGR63044A000
GE3K G 1 1/2 R	35 MPa	25	65	29,5	124	66,5	14	83,5	55	89	180	116,5	24	G 1 1/2	60	14	25	2,756	GK3GGR73011A000	GK3GGR73044A000

GE3K ANSI/ASME B1.20.1 NPT

Standard

TYPE	PN	DN	A	B	C	D	E	F	G	G1	H	I	L	ØM	CH	SW	ØLW	KG	CARBON STEEL	STAINLESS STEEL
																			ITEM CODE	ITEM CODE
GE3K N 1/8	50 MPa	4	35	14,5	71	42,4	11	49	30	48,5	110	91,5	11	N 1/8	24	9	4	0,558	GK3NNT04011A000	GK3NNT04044A000
GE3K N 1/4	50 MPa	6	35	14,5	71	42,4	11	49	30	48,5	110	91,5	17	N 1/4	24	9	6	0,536	GK3NNT14011A000	GK3NNT14044A000
GE3K N 3/8	50 MPa	10	40	17,4	73	44,4	11	54,25	35	54,5	110	96,5	17	N 3/8	30	9	10	0,695	GK3NNT24011A000	GK3NNT24044A000
GE3K N 1/2	50 MPa	13	43	18	83	48,4	11	57	37	58,5	110	99,5	21	N 1/2	32	9	13	0,825	GK3NNT33011A000	GK3NNT33044A000
GE3K N 3/4	35/40 MPa	20	57	23,4	95	62,5	14	73,5	49	75	180	106,5	21	N 3/4	41	14	20	1,583	GK3NNT44011A000	GK3NNT43044A000
GE3K N 1	35 MPa	25	65	29,5	105	66,5	14	83,5	55	89	180	116,5	24	N 1	50	14	25	2,421	GK3NNT53011A000	GK3NNT53044A000
GE3K N 1 1/4 R	35 MPa	25	65	29,5	120	66,5	14	83,5	55	89	180	116,5	24	N 1 1/4	55	14	25	2,601	GK3NNR63011A000	GK3NNR63044A000
GE3K N 1 1/2 R	35 MPa	25	65	29,5	124	66,5	14	83,5	55	89	180	116,5	24	N 1 1/2	60	14	25	2,756	GK3NNR73011A000	GK3NNR73044A000

+ GE3K 3-WAY HIGH PRESSURE BALL VALVES

www.gemels.it

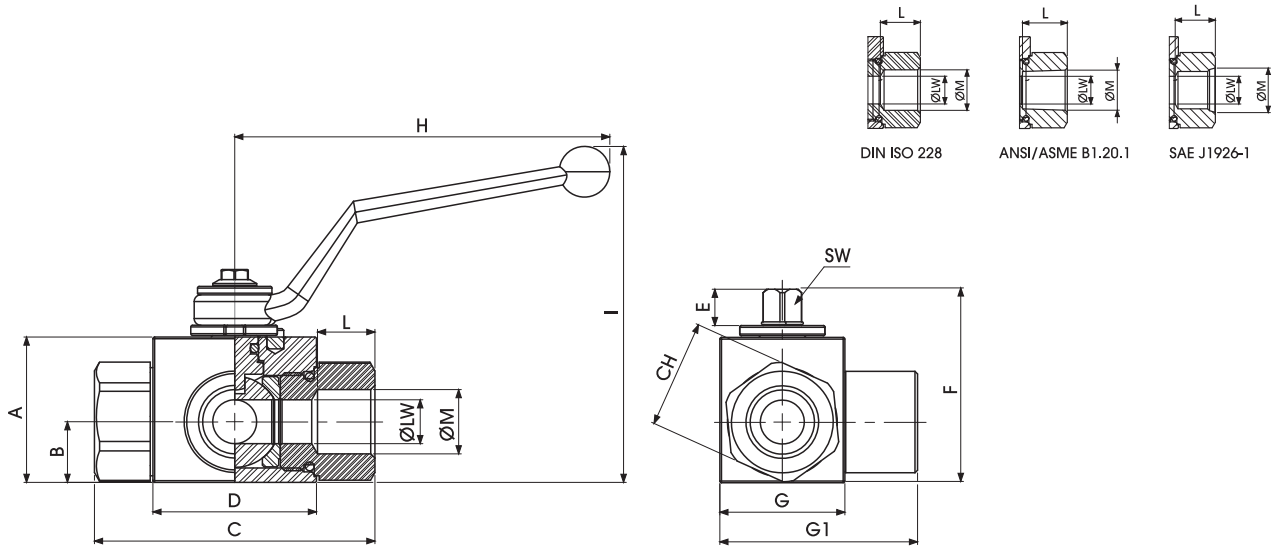

GE3K SAE J1926-1

Standard

TYPE	PN	DN	A	B	C	D	E	F	G	G1	H	I	L	ØM	CH	SW	ØLW	KG	CARBON STEEL	STAINLESS STEEL
																			ITEM CODE	ITEM CODE
GE3K SAE4	50 MPa	6	35	14,5	71	42,4	11	49	30	48,5	110	91,5	15,5	7/16 UNF	24	9	6	0,536	GK3EEE04011A000	GK3EEE04044A000
GE3K SAE6	50 MPa	10	40	17,4	73	44,4	11	54,25	35	54,5	110	96,5	16	9/16 UNF	30	9	10	0,695	GK3EEE14011A000	GK3EEE14044A000
GE3K SAE8	50 MPa	13	43	18	83	48,4	11	57	37	58,5	110	99,5	17,5	3/4 UNF	32	9	13	0,825	GK3EEE23011A000	GK3EEE23044A000
GE3K SAE12	35/40 MPa	20	57	23,4	95	62,5	14	73,5	49	75	180	106,5	23	1 1/16 UNF	41	14	20	1,583	GK3EEE34011A000	GK3EEE34044A000
GE3K SAE16	35 MPa	25	65	29,5	105	66,5	14	83,5	55	89	180	116,5	23	1 5/16 UNF	50	14	25	2,421	GK3EEE43011A000	GK3EEE43044A000
GE3K SAE20R	35 MPa	25	65	29,5	120	66,5	14	83,5	55	89	180	116,5	23	1 5/8 UNF	55	14	25	2,601	GK3EEE53011A000	GK3EEE53044A000
GE3K SAE24R	35 MPa	25	65	29,5	124	66,5	14	83,5	55	89	180	116,5	23	1 7/8 UNF	60	14	25	2,756	GK3EEE63011A000	GK3EEE63044A000

+ GE3K 3-WAY HIGH PRESSURE BALL VALVES

www.gemels.it

2016 - Edition 1

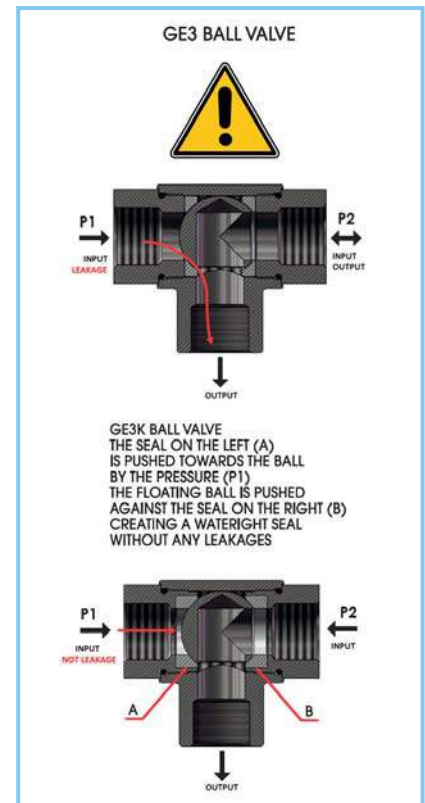
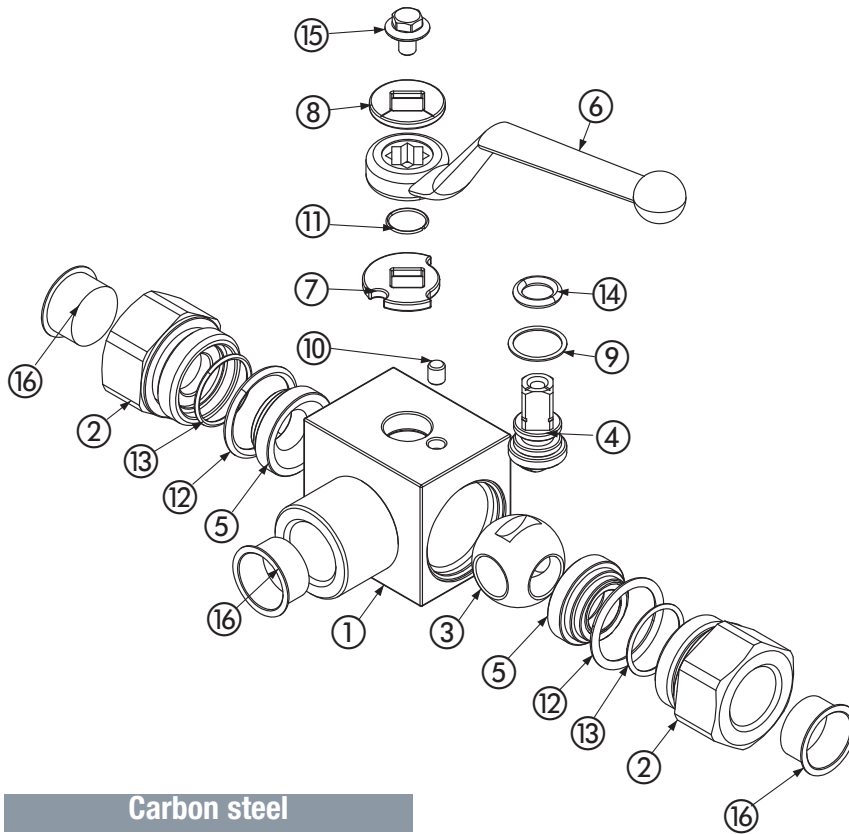

Carbon steel			
Pos	Description	Material	Q.tà
1	Body	1,0737	1
2	Adapter	1,0737	2
3	Ball	1,0737	1
4	Stem	1,0737	1
5	Ball seat	POM	2
6	Handle	ZINC	1
7	Washer	1,0116	1
8	Washer	1,0116	1
9	Stem ring	POM	1
10	Spine	1,0737	1
11	Seeger	1,4301	1
12	Adapter o-ring	NBR	2
13	Seal o-ring	NBR	2
14	Stem o-ring	NBR	1
15	Screw	Din 6921 8.8	1
16	Caps	PVC	3

On request

- Reduced bore
- O-Ring in FKM, EPDM, HNBR, KALREZ
- Seals in PTFE, PEEK, PA612, GEMPTFE, METAL TO METAL
- Special threads
- Stem in stainless steel 1,4404
- Ball in stainless steel 1,4404
- Pressure class up to PN40 MPa
- Pneumatic and electrical actuator
- Security block
- Locking device

"The company reserves the right to operate dimensional changes without prior notice".

Stainless steel			
Pos	Description	Material	Q.tà
1	Body	1,4404	1
2	Adapter	1,4404	2
3	Ball	1,4404	1
4	Stem	1,4404	1
5	Ball seat	POM	2
6	Handle	ZINC	1
7	Washer	1,0116	1
8	Washer	1,4301	1
9	Stem ring	POM	1
10	Spine	1,4301	1
11	Seeger	1,4301	1
12	Adapter o-ring	NBR	2
13	Seal o-ring	NBR	2
14	Stem o-ring	NBR	1
15	Screw	Din 6921 A2	1
16	Caps	PVC	3

On request

- Reduced bore
- O-Ring in FKM, EPDM, HNBR, KALREZ
- Seals in PTFE, PEEK, PA612, GEMPTFE, METAL TO METAL
- Special threads
- Pressure class up to PN40 MPa
- Pneumatic and electrical actuator
- Security block
- Locking device

+ GEF

2-WAY HIGH PRESSURE BALL VALVES



CARBON STEEL

- Type: ball valve GEF 2 way
- Body: block
- Material: 1,0737
- Ball seats: from DN13 up to DN25
- O-Rings: NBR, FKM, EPDM, MVQ
- Operating pressure: S3000 (PN210) S6000 (PN420) depending on valve size and seal materials selected
- Temp range: -20°C to +100°C depending on seal material selected

GE	F3	DN13	1	1	1	1	A	B
Type and way of valve GE 2-way	Valves dimension of pressure (psi) F3 F6	Nominal dimension DN13 DN20 DN25	Body material 1 1,0737	Adapter material 1 1,0737	Stem material 1 1,0737	Ball material 1 1,0737	Ball seat material A POM D PEEK G PA612 K GEMPTFE C PTFE	Adapter and stem seal material B NBR E FKM F EPDM L MVQ

STAINLESS STEEL

- Type: ball valve GEF 2 way
- Body: block
- Material: 1,4404
- Ball seats: from DN13 up to DN25
- O-Rings: NBR, FKM, EPDM, MVQ
- Operating pressure: S3000 (PN210) S6000 (PN420) depending on valve size and seal materials selected
- Temp range: -30°C to +100°C different temperatures on request

GE	F3	DN13	4	4	4	4	A	B
Type and way of valve GE 2-way	Valves dimension of pressure (psi) F3 F6	Nominal dimension DN13 DN20 DN25	Body material 4 1,4404	Adapter material 4 1,4404	Stem material 4 1,4404	Ball material 4 1,4404	Ball seat material A POM D PEEK G PA612 K GEMPTFE C PTFE	Adapter and stem seal material B NBR E FKM F EPDM L MVQ

"The company reserves the right to operate dimensional changes without prior notice".



2-WAY HIGH PRESSURE BALL VALVES

Specialist in Ball Valves

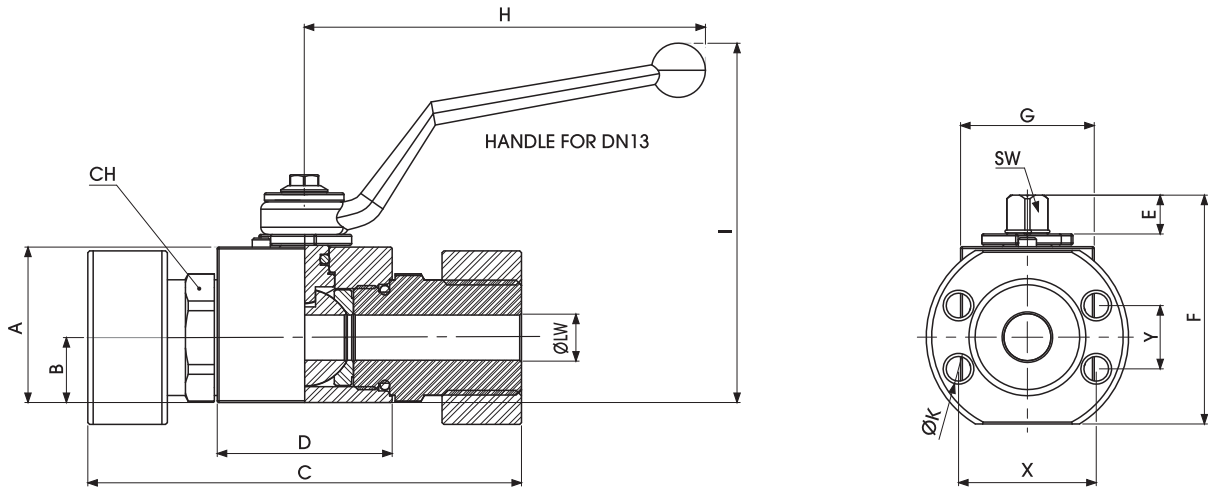

GEF SAE J518 S3000

Standard

CARBON STEEL STAINLESS STEEL

TYPE	PN	DN	A	B	C	D	E	F	G	H	I	CH	X	Y	ØK	SW	ØLW	KG	ITEM CODE	ITEM CODE
GEF3	5000 Psi	13	43	18	120	48,4	11	57	37	110	99,5	32	38,1	17,5	M8	9	13	1,504	GE2FFC0L011A000	GE2FFC0L044A000
GEF3	5000 Psi	20	55	23,4	136	62,5	14	73,5	45	180	106,5	41	47,6	22,2	M10	14	20	2,608	GE2FFC1L011A000	GE2FFC1L044A000
GEF3	5000 Psi	25	65	29,5	148	66,5	14	83,5	55	180	116,5	50	52,4	26,2	M10	14	25	3,891	GE2FFC2L011A000	GE2FFC2L044A000

GEF SAE J518 S3000 UNC

Standard

CARBON STEEL STAINLESS STEEL

TYPE	PN	DN	A	B	C	D	E	F	G	H	I	CH	X	Y	ØK	SW	ØLW	KG	ITEM CODE	ITEM CODE
GEF3	5000 Psi	13	43	18	120	48,4	11	57	37	110	99,5	32	38,1	17,5	$5/16-18$ UNC	9	13	1,504	GE2FUC0L011A000	GE2FUC0L044A000
GEF3	5000 Psi	20	55	23,4	136	62,5	14	73,5	45	180	106,5	41	47,6	22,2	$3/8-16$ UNC	14	20	2,608	GE2FUC1L011A000	GE2FUC1L044A000
GEF3	5000 Psi	25	65	29,5	148	66,5	14	83,5	55	180	116,5	50	52,4	26,2	$3/8-16$ UNC	14	25	3,891	GE2FUC2L011A000	GE2FUC2L044A000

+ GEF

2-WAY HIGH PRESSURE BALL VALVES

www.gemels.it

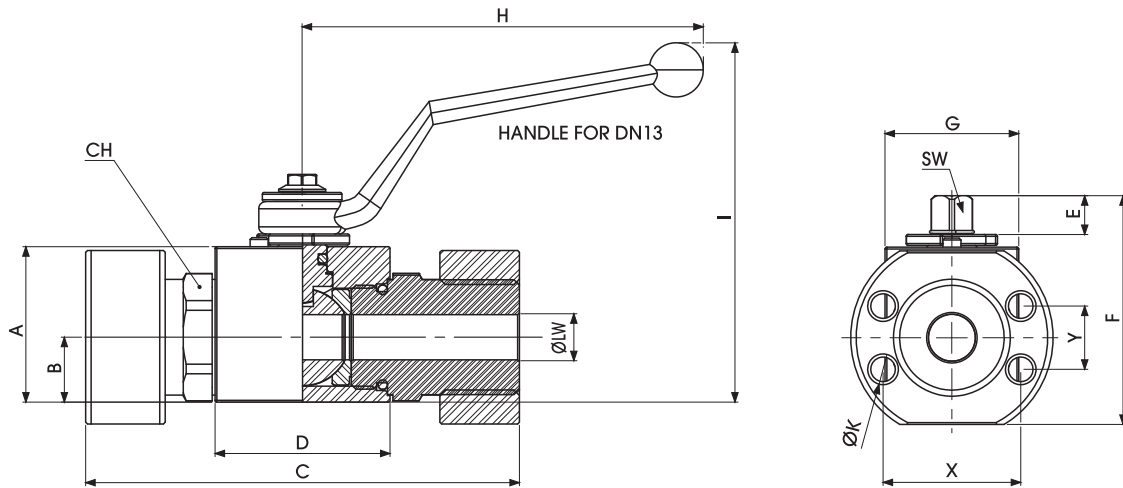

GEF SAE J518 S6000

Standard

TYPE	PN	DN	A	B	C	D	E	F	G	H	I	CH	X	Y	ØK	SW	ØLW	KG	CARBON STEEL	STAINLESS STEEL
																			ITEM CODE	ITEM CODE
GEF6	6000 Psi	13	43	18	120	48,4	11	57	37	110	99,5	32	40,5	18,2	M8	9	13	1,504	GE2FFC6G011A000	GE2FFC6G044A000
GEF6	5800 Psi	20	55	23,4	136	62,5	14	73,5	45	180	106,5	41	50,8	23,8	M10	14	20	2,608	GE2FFC74011A000	GE2FFC74044A000
GEF6	5000 Psi	25	65	29,5	148	66,5	14	83,5	55	180	116,5	50	57,2	27,8	M12	14	25	3,891	GE2FFC83011A000	GE2FFC83044A000

GEF SAE J518 S6000 UNC

Standard

TYPE	PN	DN	A	B	C	D	E	F	G	H	I	CH	X	Y	ØK	SW	ØLW	KG	CARBON STEEL	STAINLESS STEEL
																			ITEM CODE	ITEM CODE
GEF6	6000 Psi	13	43	18	120	48,4	11	57	37	110	99,5	32	40,5	18,2	$5/16-18$ UNC	9	13	1,504	GE2FUC6G011A000	GE2FUC6G044A000
GEF6	5800 Psi	20	55	23,4	136	62,5	14	73,5	45	180	106,5	41	50,8	23,8	$3/8-16$ UNC	14	20	2,608	GE2FUC74011A000	GE2FUC74044A000
GEF6	5000 Psi	25	65	29,5	148	66,5	14	83,5	55	180	116,5	50	57,2	27,8	$7/16-14$ UNC	14	25	3,891	GE2FUC83011A000	GE2FUC83044A000

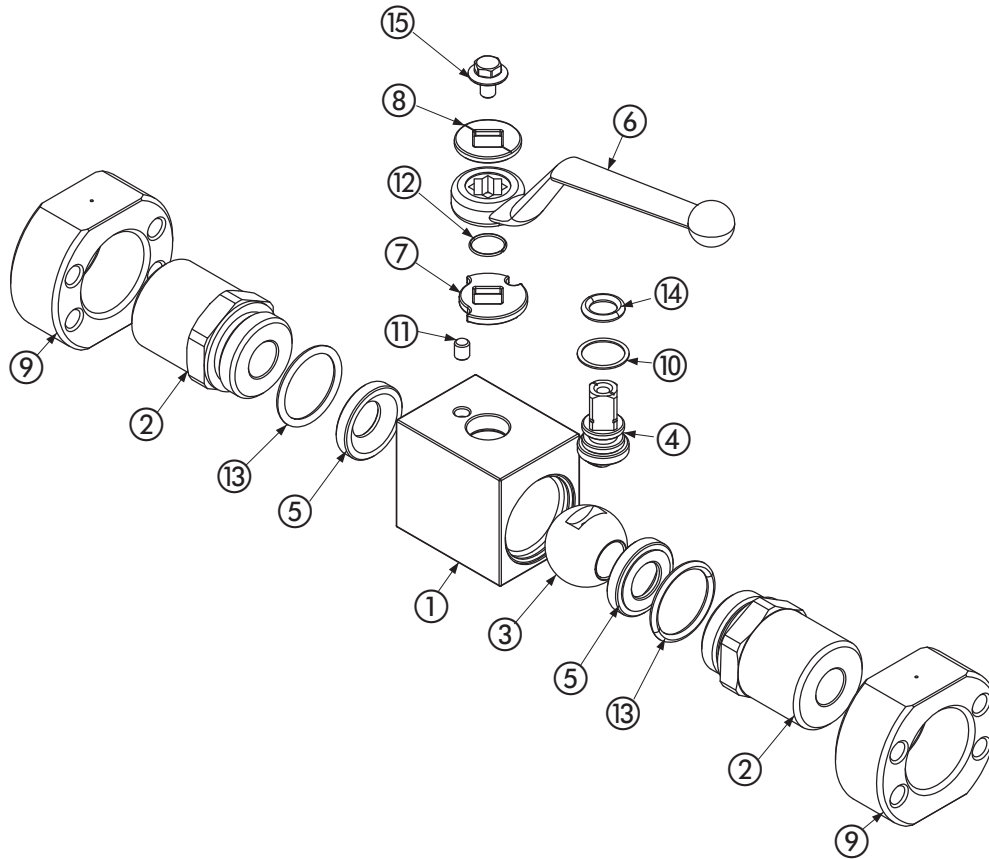

Carbon steel

Pos	Description	Material	Q.tà
1	Body	1,0737	1
2	Adapter	1,0737	2
3	Ball	1,0737	1
4	Stem	1,0737	1
5	Ball seat	POM	2
6	Handle	ZINC	1
7	Washer	1,0116	1
8	Washer	1,0116	1
9	Flange	1,0737	2
10	Stem ring	POM	1
11	Spine	1,0737	1
12	Seeger	1,4301	1
13	Adapter o-ring	NBR	2
14	Stem o-ring	NBR	1
15	Screw	Din 6921 8.8	1

On request

- Reduced bore
- O-Ring in FKM, EPDM, HNBR, KALREZ
- Seals in PTFE, PEEK, PA612, GEMPTFE, METAL TO METAL
- Special threads
- Stem in stainless steel 1,4404
- Ball in stainless steel 1,4404
- Pressure class up to PN6000 Psi
- Pneumatic and electrical actuator
- Locking device

Stainless steel

Pos	Description	Material	Q.tà
1	Body	1,4404	1
2	Adapter	1,4404	2
3	Ball	1,4404	1
4	Stem	1,4404	1
5	Ball seat	POM	2
6	Handle	ZINC	1
7	Washer	1,4301	1
8	Washer	1,4301	1
9	Flange	1,4404	2
10	Stem ring	POM	1
11	Spine	1,4301	1
12	Seeger	1,4301	1
13	Adapter o-ring	NBR	2
14	Stem o-ring	NBR	1
15	Screw	Din 6921 A2	1

On request

- Reduced bore
- O-Ring in FKM, EPDM, HNBR, KALREZ
- Seals in PTFE, PEEK, PA612, GEMPTFE, METAL TO METAL
- Special threads
- Pressure class up to PN6000 Psi
- Pneumatic and electrical actuator
- Locking device

For further special requests please consult our technical/commercial service

+ GES

2-WAY HIGH PRESSURE BALL VALVES

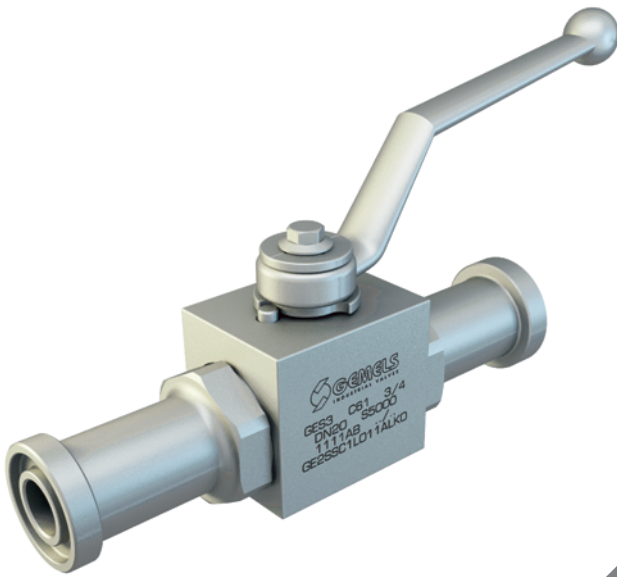

CARBON STEEL

- Type: ball valve GES 2 way
- Body: block
- Material: 1,0737
- Ball seats: from DN13 up to DN25
- O-Rings: NBR, FKM, EPDM, MVQ
- Operating pressure: S3000 (PN210) S6000 (PN420) depending on valve size and seal materials selected
- Temp range: -20°C to +100°C depending on seal material selected

GE	S3	DN13	1	1	1	1	A	B
Type and way of valve GE 2-way	Valves dimension of pressure (psi) S3 S6	Nominal dimension DN13 DN20 DN25	Body material 1 1,0737	Adapter material 1 1,0737	Stem material 1 1,0737	Ball material 1 1,0737	Ball seat material A POM D PEEK G PA612 K GEMPTFE C PTFE	Adapter and stem seal material B NBR E FKM F EPDM L MVQ

STAINLESS STEEL

- Type: ball valve GES 2 way
- Body: block
- Material: 1,4404
- Ball seats: from DN13 up to DN25
- O-Rings: NBR, FKM, EPDM, MVQ
- Operating pressure: S3000 (PN210) S6000 (PN420) depending on valve size and seal materials selected
- Temp range: -30°C to +100°C different temperatures on request

GE	S3	DN13	4	4	4	4	A	B
Type and way of valve GE 2-way	Valves dimension of pressure (psi) S3 S6	Nominal dimension DN13 DN20 DN25	Body material 4 1,4404	Adapter material 4 1,4404	Stem material 4 1,4404	Ball material 4 1,4404	Ball seat material A POM D PEEK G PA612 K GEMPTFE C PTFE	Adapter and stem seal material B NBR E FKM F EPDM L MVQ

"The company reserves the right to operate dimensional changes without prior notice".



2-WAY HIGH PRESSURE BALL VALVES

Specialist in Ball Valves

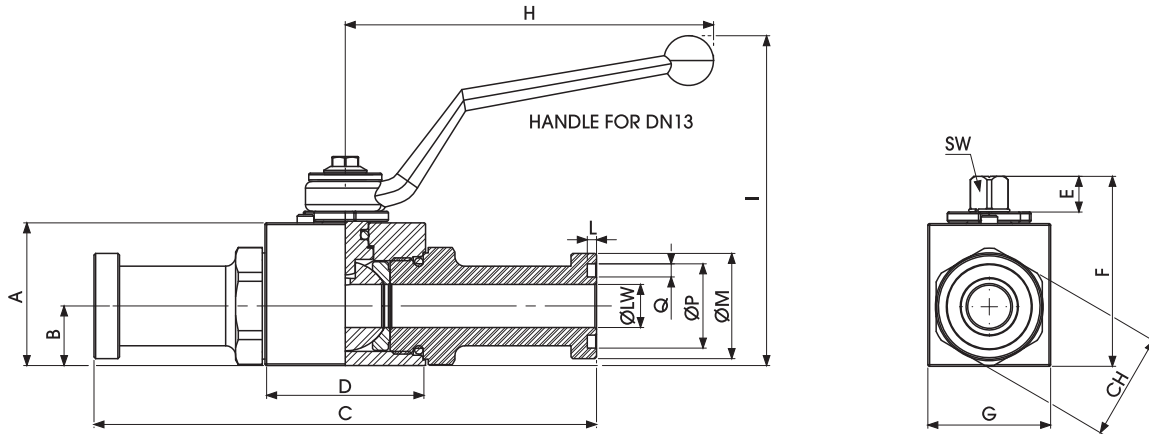

GES SAE J518 S3000

Standard

		CARBON STEEL																	STAINLESS STEEL		
TYPE	PN	DN	A	B	C	D	E	F	G	H	I	L	ØM	CH	ØP	Q	SW	ØLW	KG	ITEM CODE	ITEM CODE
GES3	5000 Psi	13	43	18	151,5	48,4	11	57	37	110	99,5	2,79	30,2	32	25,4	3,94	9	13	0,96	GE2SSC0L011A000	GE2SSC0L044A000
GES3	5000 Psi	20	55	23,4	162	62,5	14	73,5	45	180	106,5	2,79	38,1	41	31,75	3,94	14	20	1,717	GE2SSC1L011A000	GE2SSC1L044A000
GES3	5000 Psi	25	65	29,5	178	66,5	14	83,5	55	180	116,5	2,79	44,4	50	39,2	3,94	14	25	2,597	GE2SSC2L011A000	GE2SSC2L044A000

+ GES

2-WAY HIGH PRESSURE BALL VALVES

www.gemels.it

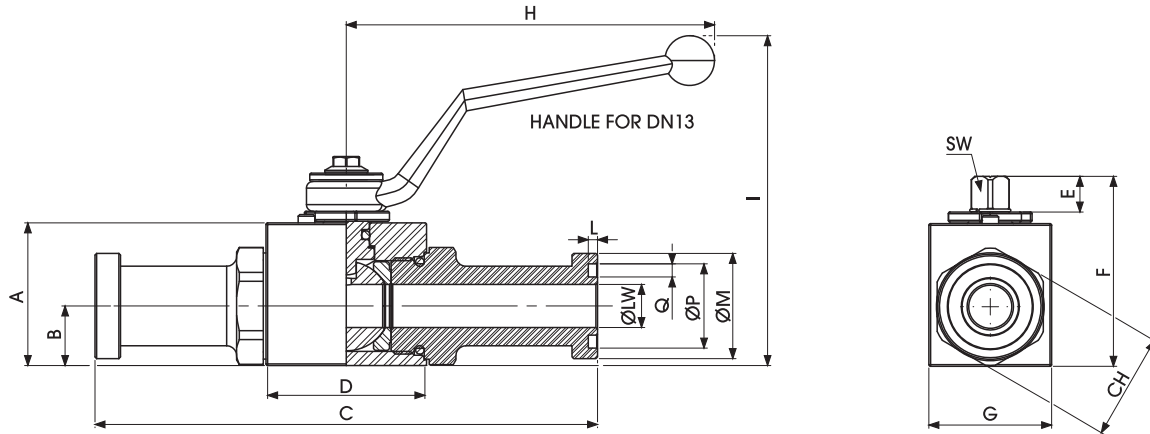

GES SAE J518 S6000

Standard

TYPE	PN	DN	A	B	C	D	E	F	G	H	I	L	ØM	CH	ØP	Q	SW	ØLW	KG	CARBON STEEL	STAINLESS STEEL
																				ITEM CODE	ITEM CODE
GES6	6000 Psi	13	43	18	151,5	48,4	11	57	37	110	99,5	2,79	31,6	32	25,4	3,94	9	13	0,956	GE2SSC6G011A000	GE2SSC6G044A000
GES6	5800 Psi	20	55	23,4	174	62,5	14	73,5	45	180	106,5	2,79	41,3	41	31,75	3,94	14	20	1,792	GE2SSC74011A000	GE2SSC74044A000
GES6	5000 Psi	25	65	29,5	198	66,5	14	83,5	55	180	116,5	2,79	47,8	50	39,2	3,94	14	25	2,759	GE2SSC83011A000	GE2SSC83044A000

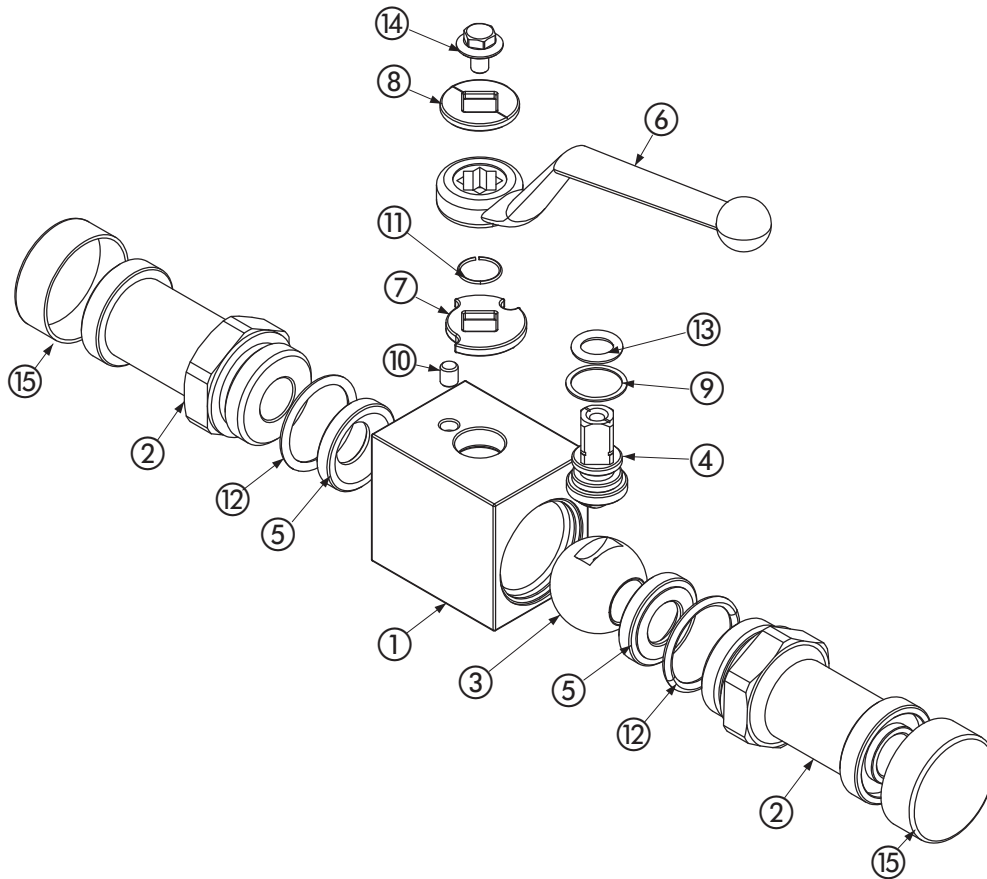

Carbon steel

Pos	Description	Material	Q.tà
1	Body	1,0737	1
2	Adapter	1,0737	2
3	Ball	1,0737	1
4	Stem	1,0737	1
5	Ball seat	POM	2
6	Handle	ZINC	1
7	Washer	1,0116	1
8	Washer	1,0116	1
9	Stem ring	POM	1
10	Spine	1,0737	1
11	Seeger	1,4301	1
12	Adapter o-ring	NBR	2
13	Stem o-ring	NBR	1
14	Screw	Din 6921 8.8	1
15	Caps	PVC	2

On request

- Reduced bore
- O-Ring in FKM, EPDM, HNBR, KALREZ
- Seals in PTFE, PEEK, PA612, GEMPTFE, METAL TO METAL
- Special threads
- Stem in stainless steel 1,4404
- Ball in stainless steel 1,4404
- Pressure class up to PN6000 Psi
- Pneumatic and electrical actuator
- Locking device

Stainless steel

Pos	Description	Material	Q.tà
1	Body	1,4404	1
2	Adapter	1,4404	2
3	Ball	1,4404	1
4	Stem	1,4404	1
5	Ball seat	POM	2
6	Handle	ZINC	1
7	Washer	1,4301	1
8	Washer	1,4301	1
9	Stem ring	POM	1
10	Spine	1,4301	1
11	Seeger	1,4301	1
12	Adapter o-ring	NBR	2
13	Stem o-ring	NBR	1
14	Screw	Din 6921 A2	1
15	Caps	PVC	2

On request

- Reduced bore
- O-Ring in FKM, EPDM, HNBR, KALREZ
- Seals in PTFE, PEEK, PA612, GEMPTFE, METAL TO METAL
- Special threads
- Pressure class up to PN6000 Psi
- Pneumatic and electrical actuator
- Locking device

For further special requests please consult our technical/commercial service

+ GEC

2-WAY HIGH PRESSURE BALL VALVES



CARBON STEEL

- Type: ball valve GEC 2 way
- Body: square
- Material: 1,0737
- Ball seats: from DN6 up to DN25
- O-Rings: NBR, FKM, EPDM, MVQ
- Operating pressure: 500 Bar depending on valve size and seal materials selected
- Temp range: -20°C to +100°C depending on seal material selected

GEC	SAE8 M			DN13	1	1	1	1	A	B
Type and way of valve	Valves dimension of pressure (psi)			Nominal dimension	Body material	Adapter material	Stem material	Ball material	Ball seat material	Adapter and stem seal material
GEC 2-way	MALE	FEMALE	MALE-FEMALE							
	SAE4	SAE4	SAE4	DN6	1 1,0737	1 1,0737	1 1,0737	1 1,0737	A POM	B NBR
	SAE6	SAE6	SAE6	DN20					D PEEK	E FKM
	SAE8	SAE8	SAE8	DN10					G PA612	F EPDM
	SAE12	SAE12	SAE12	DN13					K GEMPTFE	L MVQ
	SAE16	SAE16	SAE16	DN20					C PTFE	
				DN25						



2-WAY HIGH PRESSURE BALL VALVES

Specialist in Ball Valves

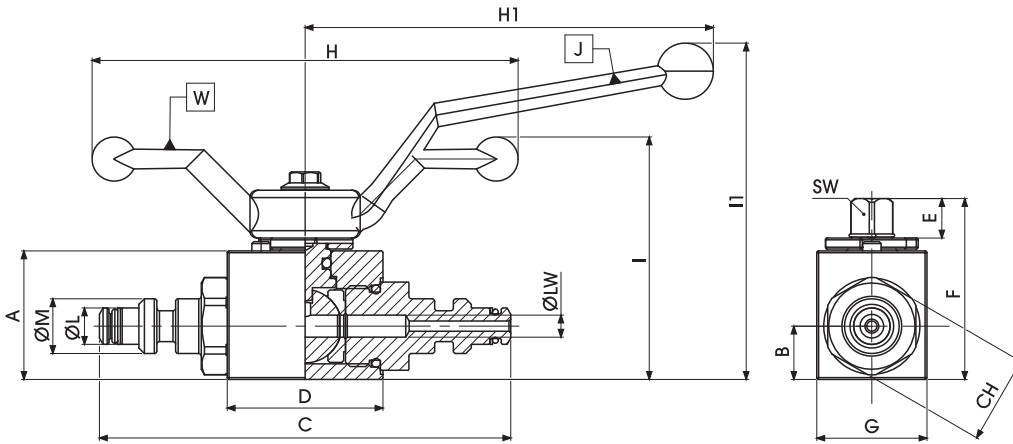

(***) ABOUT HANDLE, THE FINAL CODE WILL BE:
 000 STANDARD HANDLE (J)
 021 BUTTERFLY HANDLE (W)
 FROM DN6 TO DN25

GEC MALE SAEJ1467

Standard

CARBON STEEL

TYPE	PN	DN	A	B	C	D	E	F	G	H	H1	I	I1	ØL	ØM	CH	SW	ØLW	KG	ITEM CODE
GEC SAE4	50 MPa	6	35	42	112	42,4	11	49	30	116	110	66	91,5	10	15	24	9	6	0,584	GE2MCE05011A(***)
GEC SAE6	50 MPa	10	40	44	115	44,4	11	54,25	35	116	110	71	96,5	14	20	30	9	10	0,766	GE2MCE15011A(***)
GEC SAE8	50 MPa	13	43	48	117	48,4	11	57	37	116	110	74	99,5	18	24	32	9	13	0,891	GE2MCE25011A(***)
GEC SAE12	40 MPa	20	55	62	133	62,5	14	73,5	45	116	180	87	106,5	24	29	41	14	20	1,565	GE2MCE34011A(***)
GEC SAE16	35 MPa	25	65	66,5	151,5	66,5	14	83,5	55	116	180	97	116,5	31	39	50	14	25	2,396	GE2MCE43011A(***)

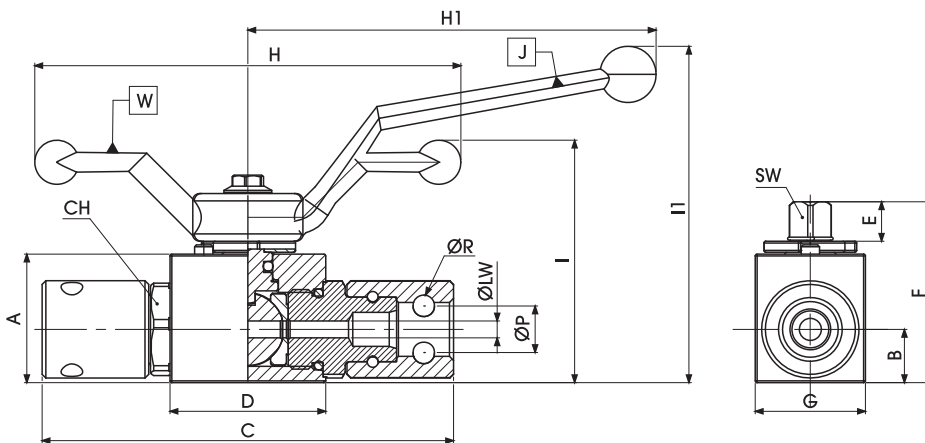

(***) ABOUT HANDLE, THE FINAL CODE WILL BE:
 000 STANDARD HANDLE (J)
 021 BUTTERFLY HANDLE (W)
 FROM DN6 TO DN25

GEC FEMALE SAEJ1467

Standard

CARBON STEEL

TYPE	PN	DN	A	B	C	D	E	F	G	H	H1	I	I1	CH	ØP	ØR	SW	ØLW	KG	ITEM CODE
GEC SAE4	50 MPa	6	35	42	112	42,4	11	49	30	116	110	66	91,5	24	13	6	9	6	0,584	GE2FCE05011A(***)
GEC SAE6	50 MPa	10	40	44	115	44,4	11	54,25	35	116	110	71	96,5	30	18	6	9	10	0,766	GE2FCE15011A(***)
GEC SAE8	50 MPa	13	43	48	117	48,4	11	57	37	116	110	74	99,5	32	22	6	9	13	0,891	GE2FCE25011A(***)
GEC SAE12	40 MPa	20	55	62	133	62,5	14	73,5	45	116	180	87	106,5	41	27	6	14	20	1,565	GE2FCE34011A(***)
GEC SAE16	35 MPa	25	65	66,5	151,5	66,5	14	83,5	55	116	180	97	116,5	50	36	8,5	14	25	2,396	GE2FCE43011A(***)

+ GEC

2-WAY HIGH PRESSURE BALL VALVES

www.gemels.it

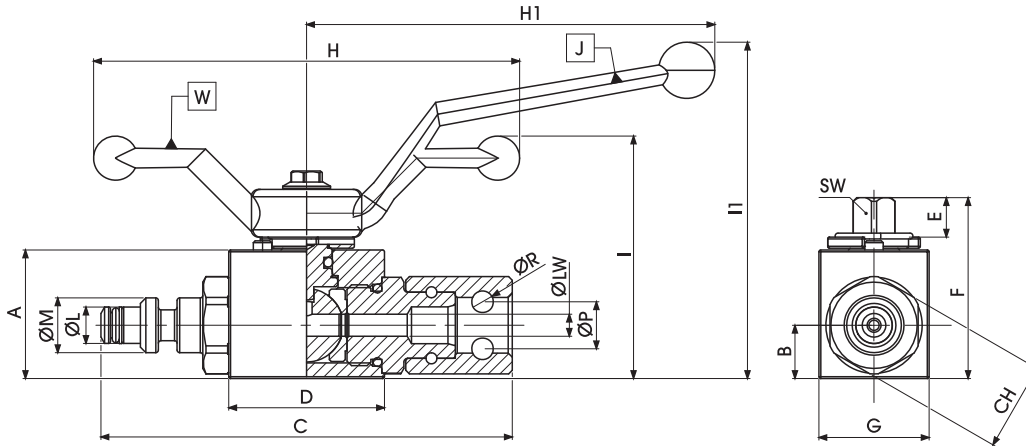

(***)
ABOUT HANDLE, THE FINAL CODE WILL BE:
000 STANDARD HANDLE (J)
021 BUTTERFLY HANDLE (W)
FROM DN6 TO DN25

GEC MALE FEMALE SAEJ1467

Standard

CARBON STEEL

TYPE	PN	DN	A	B	C	D	E	F	G	H	H1	I	I1	ØL	ØM	CH	ØP	ØR	SW	ØLW	KG	ITEM CODE
GEC SAE4	50 MPa	6	35	42	112	42,4	11	49	30	116	110	66	91,5	10	15	24	13	6	9	6	0,584	GE2MFE05011A(***)
GEC SAE6	50 MPa	10	40	44	115	44,4	11	54,25	35	116	110	71	96,5	14	20	30	18	6	9	10	0,766	GE2MFE15011A(***)
GEC SAE8	50 MPa	13	43	48	117	48,4	11	57	37	116	110	74	99,5	18	24	32	22	6	9	13	0,891	GE2MFE25011A(***)
GEC SAE12	40 MPa	20	55	62	133	62,5	14	73,5	45	116	180	87	106,5	24	29	41	27	6	14	20	1,565	GE2MFE34011A(***)
GEC SAE16	35 MPa	25	65	66,5	151,5	66,5	14	83,5	55	116	180	97	116,5	31	39	50	36	8,5	14	25	2,396	GE2MFE43011A(***)

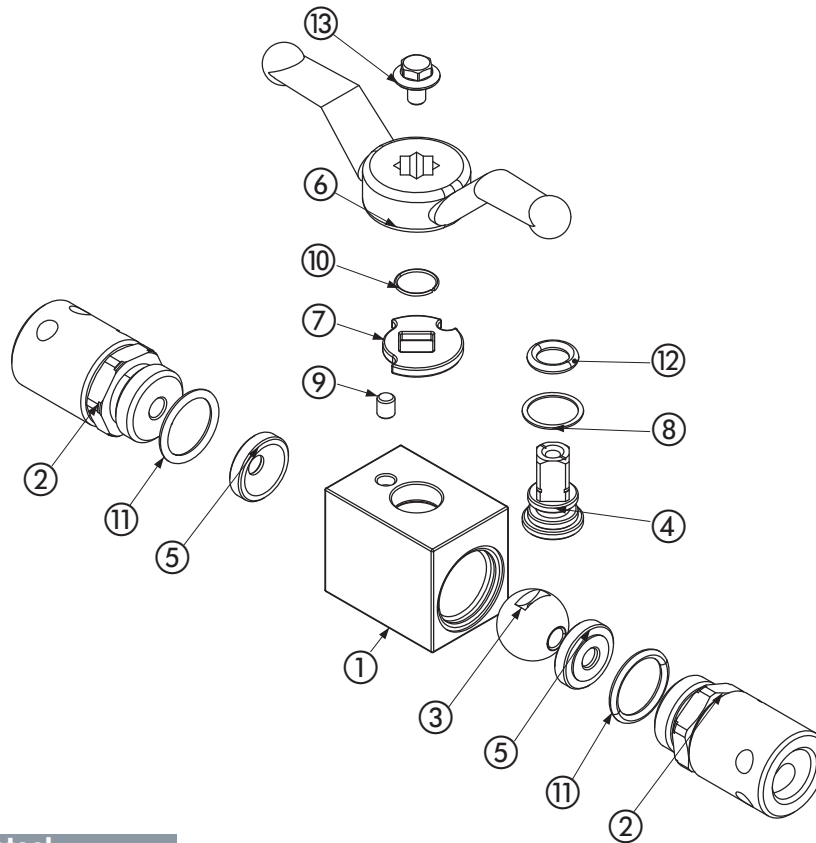

Carbon steel

Pos	Description	Material	Q.tà
1	Body	1,0737	1
2	Adapter	1,0737	2
3	Ball	1,0737	1
4	Stem	1,0737	1
5	Ball seat	POM	2
6	Handle	ZINC	1
7	Washer	1,0116	1
8	Stem ring	POM	1
9	Spine	1,0737	1
10	Seeger	1,4301	1
11	Adapter o-ring	NBR	2
12	Stem o-ring	NBR	1
13	Screw	Din 6921 8.8	1

- On request**
- Reduced bore
 - O-Ring in FKM, EPDM, HNBR, KALREZ
 - Seals in PTFE, PEEK, PA612, GEMPTFE, METAL TO METAL
 - Special threads
 - Stem in stainless steel 1,4404
 - Ball in stainless steel 1,4404
 - Pressure class up to PN50 Mpa
 - Pneumatic and electrical actuator
 - Locking device

• For further special requests please consult our technical/commercial service

+ GEV

SHUTTLE VALVES

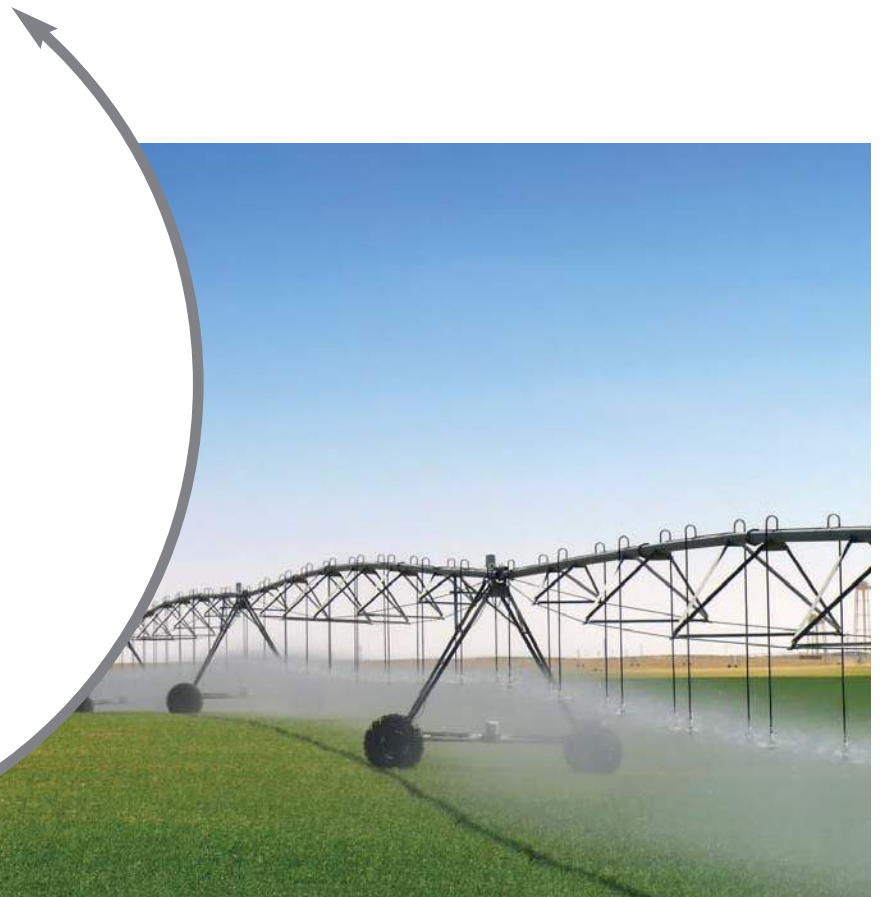

CARBON STEEL

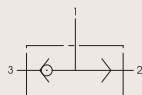

- Type: ball valve GEV 3 way
- Body: square
- Material: 1,0737
- Ball seats: from DN6 up to DN25
- Operating pressure: PN 250
- Temp range: -20°C to +100°C depending on seal material selected

	GEV		G 1/2		DN13	CS	
Type and way of valve	GAS DIN/ISO 228 BSP	NPT ANSI/ASME B1.20.1	SAE J1926-1	DIN 2353 HEAVY SERIES	DIN 2353 LIGHT SERIES	Nominal dimension	Material
GEV 3-way	G 1/8	N 1/8	SAE4	8S	8L	DN6	CS Carbon steel
	G 1/4	N 1/4	SAE6	14S	10L	DN10	
	G 3/8	N 3/8	SAE8	20S	15L	DN13	
	G 1/2	N 1/2	SAE12	25S	22L	DN20	
	G 3/4	N 3/4	SAE16	30S	28L	DN25	
	G 1	N 1	SAE20R				

+ GEV SHUTTLE VALVES

Specialist in Ball Valves

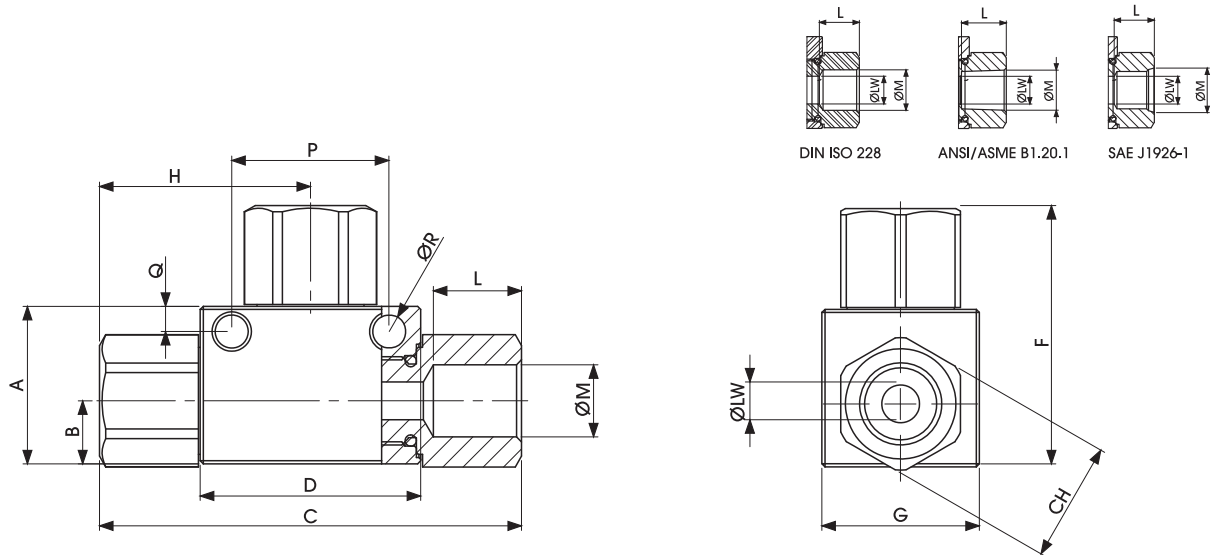

GEV DIN/ISO 228 BSP

Standard

CARBON STEEL

TYPE	PN	DN	A	B	C	D	F	G	H	L	ØM	ØLW	P	Q	ØR	CH	KG	ITEM CODE
GEV 1/4	25 Mpa	6	25	10	67	35	41	25	33,5	15,5	G 1/4	6	25	3,5	5,25	19	0,47	GEVGGT120110000
GEV 3/8	25 Mpa	10	40	17,4	78,6	50	54,3	35	39,3	15,5	G 3/8	10	40	5	5,25	30	0,679	GEVGGT220110000
GEV 1/2	25 Mpa	13	40	17,4	88,5	55	57,3	35	44,8	17	G 1/2	13	45	5	5,25	32	0,725	GEVGGT320110000
GEV 3/4	25 Mpa	20	55	23	107,5	75	71,5	45	53,5	21	G 3/4	20	60	6	6,25	41	1,724	GEVGGT420110000
GEV 1"	25 Mpa	25	65	31	126	80	93	60	63	24	G 1"	25	60	6	6,25	50	2,917	GEVGGT520110000

GEV ANSI/ASME B1.20.1 NPT

Standard

CARBON STEEL

TYPE	PN	DN	A	B	C	D	F	G	H	L	ØM	ØLW	P	Q	ØR	CH	KG	ITEM CODE
GEV N 1/4	25 Mpa	6	25	10	67	35	41	25	33,5	15,5	N 1/4	6	25	3,5	5,25	19	0,47	GEVNNT120110000
GEV N 3/8	25 Mpa	10	40	17,4	78,6	50	54,3	35	39,3	15,5	N 3/8	10	40	5	5,25	30	0,679	GEVNNT220110000
GEV N 1/2	25 Mpa	13	40	17,4	88,5	55	57,3	35	44,8	17	N 1/2	13	45	5	5,25	32	0,725	GEVNNT320110000
GEV N 3/4	25 Mpa	20	55	23	107,5	75	71,5	45	53,5	21	N 3/4	20	60	6	6,25	41	1,724	GEVNNT420110000
GEV N 1"	25 Mpa	25	65	31	126	80	93	60	63	24	N 1"	25	60	6	6,25	50	2,917	GEVNNT520110000

GEV SAE J1926-1

Standard

CARBON STEEL

TYPE	PN	DN	A	B	C	D	F	G	H	L	ØM	ØLW	P	Q	ØR	CH	KG	ITEM CODE
GEV SAE4	25 Mpa	6	25	10	67	35	41	25	33,5	15,5	7/16 UNF	6	25	3,5	5,25	19	0,47	GEVEEE020110000
GEV SAE6	25 Mpa	10	40	17,4	78,6	50	54,3	35	39,3	15,5	9/16 UNF	10	40	5	5,25	30	0,679	GEVEEE120110000
GEV SAE8	25 Mpa	13	40	17,4	88,5	55	57,3	35	44,8	17	3/4 UNF	13	45	5	5,25	32	0,725	GEVEEE220110000
GEV SAE12	25 Mpa	20	55	23	107,5	75	71,5	45	53,5	21	1 1/16 UNF	20	60	6	6,25	41	1,724	GEVEEE320110000
GEV SAE16	25 Mpa	25	65	31	126	80	93	60	63	24	1 5/16 UNF	25	60	6	6,25	50	2,917	GEVEEE420110000

+ GEV SHUTTLE VALVES

www.gemels.it

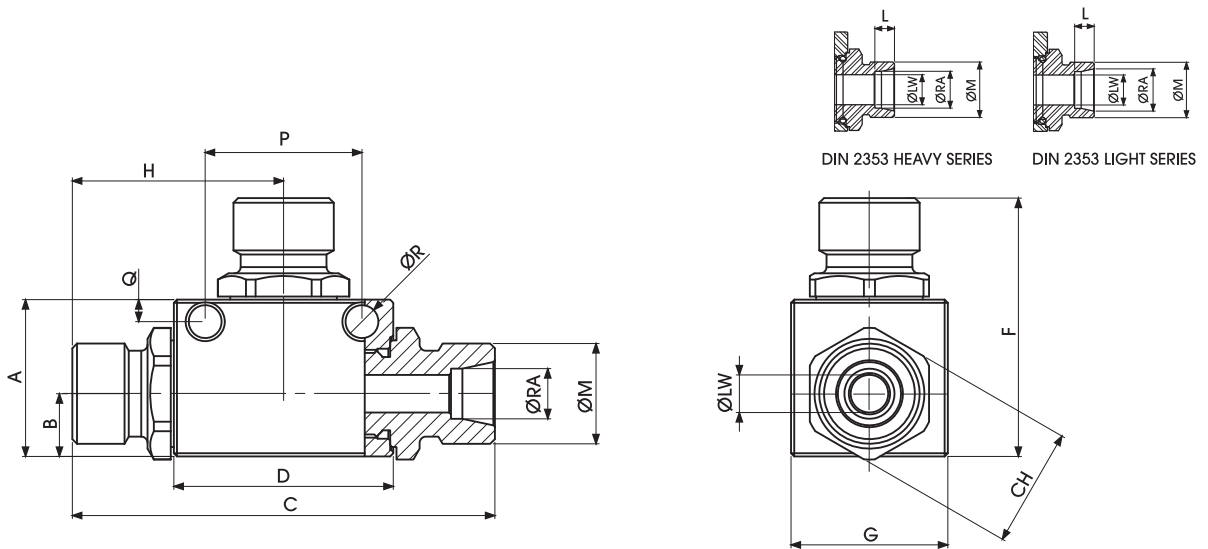

GEV DIN 2353 HEAVY SERIES

Standard

CARBON STEEL

TYPE	PN	DN	A	B	C	D	F	G	H	L	ØM	ØLW	ØRA	CH	P	Q	ØR	KG	ITEM CODE
GEV 8S	25 MPa	6	25	10	67	35	41	25	33,5	7	M16x1.5	6	8	19	25	3,5	5,25	0,438	GEVDDS020110000
GEV 14S	25 MPa	10	40	17,4	88	50	59	35	44	7	M22x1.5	10	14	30	40	5	5,25	0,759	GEVDDS320110000
GEV 20S	25 MPa	13	40	17,4	99,5	55	62	35	49,8	10,5	M30x2	13	20	32	45	5	5,25	0,776	GEVDDS520110000
GEV 25S	25 MPa	20	55	23	123,5	75	78,5	50	61,75	12	M36x2	20	25	41	60	6	6,25	1,773	GEVDDS620110000
GEV 30S	25 MPa	25	70	31	134	75	97	60	67	13,5	M42x2	25	30	50	60	6	6,25	2,696	GEVDDS720110000

GEV DIN 2353 LIGHT SERIES

Standard

CARBON STEEL

TYPE	PN	DN	A	B	C	D	F	G	H	L	ØM	ØLW	ØRA	CH	P	Q	ØR	KG	ITEM CODE
GEV 8L	25 MPa	6	25	10	67	35	41	25	33,5	6,7	M14x1.5	6	8	19	25	3,5	5,25	0,44	GEVDDL120110000
GEV 10L	25 MPa	10	40	17,4	82,2	50	56,1	35	41,1	6,7	M18x1.5	10	10	30	40	5	5,25	0,63	GEVDDL220110000
GEV 15L	25 MPa	13	40	17,4	93,6	55	59	35	46,8	7	M22x1.5	13	15	32	45	5	5,25	0,696	GEVDDL420110000
GEV 22L	25 MPa	20	55	23	122,3	75	78,5	50	61,3	7,5	M30x2	20	22	41	60	6	6,25	1,746	GEVDDL620110000
GEV 28L	25 MPa	25	70	31	131	75	95	60	65,5	7,5	M36x2	25	28	50	60	6	6,25	2,639	GEVDDL720110000

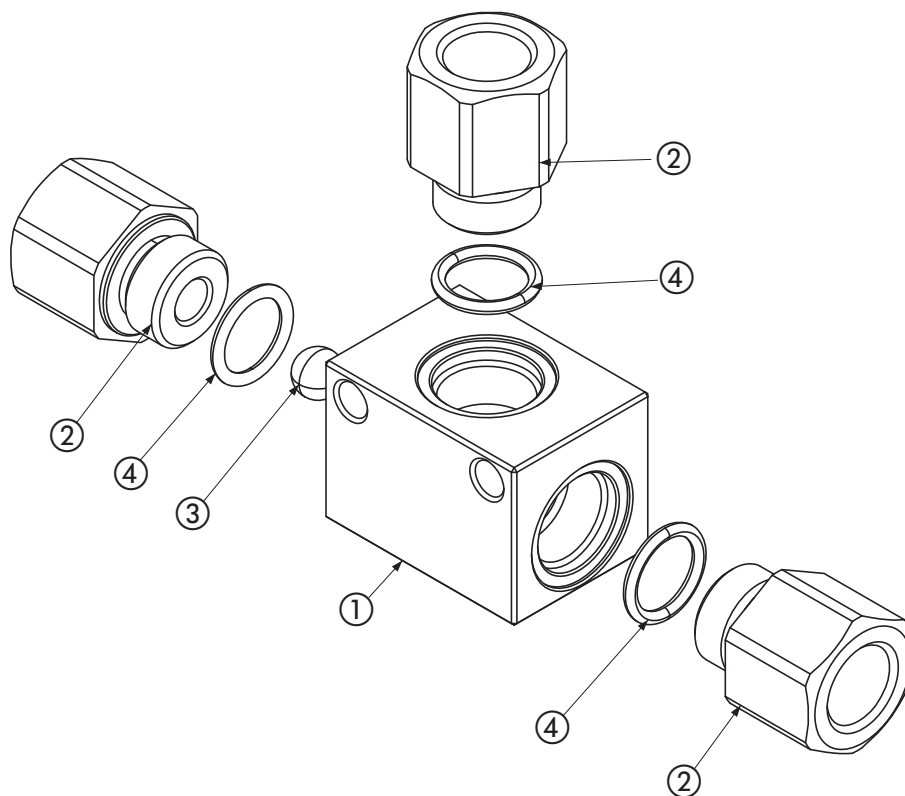

Carbon steel

Pos	Description	Material	Q.tà
1	Body	1,0737	1
2	Adapter	1,0737	2
3	Ball	UNI3545	1
4	Adapter o-ring	NBR	2

For further special requests please consult our technical/commercial service

On request

- Reduced bore
- O-Ring in FKM, EPDM, HNBR, KALREZ
- Special threads
- Pressure class up to PN25 MPa

GB

GB2 - GB3 - GBF - GBS -GBC



TECH
MATERIAL

KITS
LOCKING - HANDLES
FLANGE - LIMIT SWITCHES
ACTUATORS - SEALS KITS

OIL&GAS
GM1-GM - GN
SBF - SBT

OTHER
GHP - GPS - RF
BD - VU - VUBA

GR
GRC - GRS

GPK
GPK2 - GPK3

G3K-4K
G3K - G4K

GV
GV2 - GV3

GB
GB2 - GB3 - GBF
GBS -GBC

GE
GEM - GE1 - GE2 - GE3
GE5 - GE3K - GEF
GES - GEC - GEV

+ GB2

2-WAY HIGH PRESSURE BALL VALVES



CARBON STEEL

- Type: ball valve GB 2 way
- Body: round
- Material: 1,0570 / 1,0737
- Ball seats: from DN32 up to DN50
- O-Rings: NBR, FKM, EPDM, MVQ
- Operating pressure: 350 Bar depending on valve size and seal materials selected
- Temp range: -20°C to +100°C depending on seal material selected

	GB2		G 1 1/2		DN32		2	2	1	1	A	B
Type and way of valve	GAS DIN/ISO 228 BSP	NPT ANSI/ASME B1.20.1	SAE J1926-1	DIN 2353 HEAVY SERIES	DIN 2353 LIGHT SERIES	Nominal dimension	Body material	Adapter material	Stem material	Ball material	Ball seat material	Adapter and stem seal material
GB2 2-way	G 1 1/4	N 1 1/4	SAE20	38S	35L	DN32	2 1,0570	2 1,0570	1 1,0737	1 1,0737	A POM D PEEK G PA612 K GEMPTFE C PTFE	B NBR E FKM F EPDM L MVQ
	G 1 1/2	N 1 1/2	SAE24		42L	DN40						
	G 2R	N 2R	SAE32			DN50						
	G 2	N 2										

STAINLESS STEEL

- Type: ball valve GB 2 way
- Body: round
- Material: 1,4404
- Ball seats: from DN32 up to DN50
- O-Rings: NBR, FKM, EPDM, MVQ
- Operating pressure: 350 Bar depending on valve size and seal materials selected
- Temp range: -30°C to +100°C different temperatures on request

	GB2		G 1 1/2		DN32		4	4	4	4	A	B
Type and way of valve	GAS DIN/ISO 228 BSP	NPT ANSI/ASME B1.20.1	SAE J1926-1	DIN 2353 HEAVY SERIES	DIN 2353 LIGHT SERIES	Nominal dimension	Body material	Adapter material	Stem material	Ball material	Ball seat material	Adapter and stem seal material
GB2 2-way	G 1 1/4	N 1 1/4	SAE20	38S	35L	DN32	4 1,4404	4 1,4404	4 1,4404	4 1,4404	A POM D PEEK G PA612 K GEMPTFE C PTFE	B NBR E FKM F EPDM L MVQ
	G 1 1/2	N 1 1/2	SAE24		42L	DN40						
	G 2R	N 2R	SAE32			DN50						
	G 2	N 2										

"The company reserves the right to operate dimensional changes without prior notice".

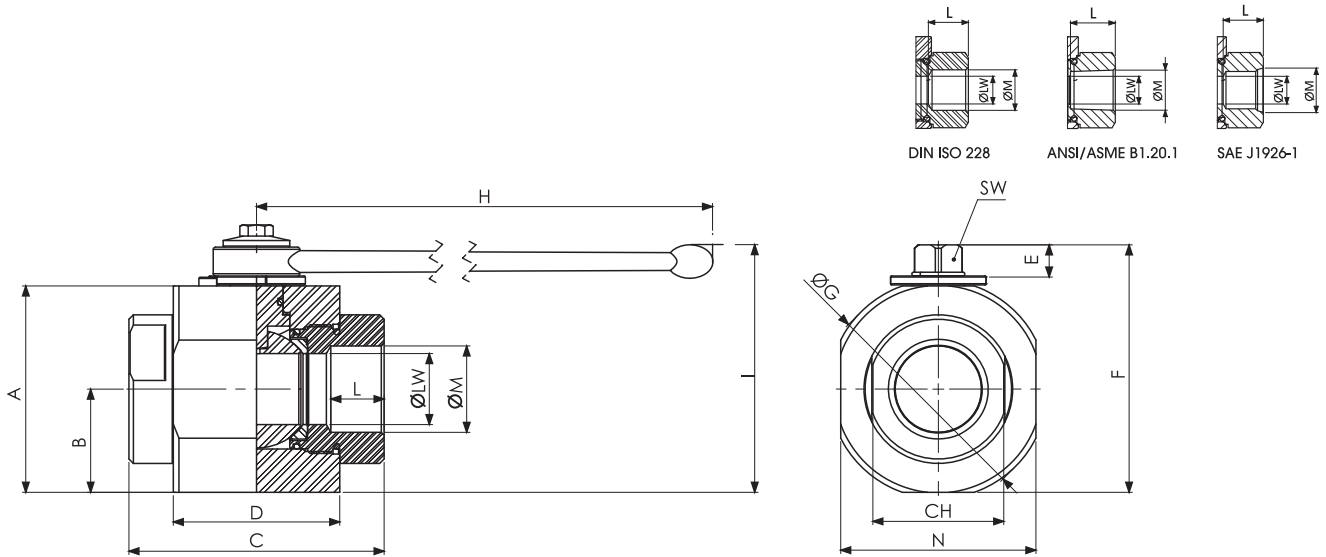

GB2 DIN/ISO 228 BSP

Standard

TYPE	PN	DN	A	B	C	D	E	F	ØG	H	I	L	ØM	N	CH	SW	ØLW	KG	CARBON STEEL	STAINLESS STEEL
																			ITEM CODE	ITEM CODE
GB2 G 1 1/4	35 MPa	32	93	46,5	115	75	13,5	111,5	98	300	120,5	24	G 1 1/4	88	60	17	32	6,975	GB2GGT63021A000	GB2GGT63044A000
GB2 G 1 1/2	35 MPa	40	107	53,5	131	85	13,5	125,5	113	300	134,5	25	G 1 1/2	102	75	17	40	7,393	GB2GGT73021A000	GB2GGT73044A000
GB2 G 2R	35 MPa	40	107	53,5	131	85	13,5	125,5	113	300	134,5	25	G 2	102	75	17	40	6,975	GB2GGR83021A000	GB2GGR83044A000
GB2 G 2	35 MPa	50	114	57	140	98	13,5	132,5	123	300	141,5	27	G 2	118	85	17	50	9,046	GB2GGT83021A000	GB2GGT83044A000

GB2 ANSI/ASME B1.20.1 NPT

Standard

TYPE	PN	DN	A	B	C	D	E	F	ØG	H	I	L	ØM	N	CH	SW	ØLW	KG	CARBON STEEL	STAINLESS STEEL
																			ITEM CODE	ITEM CODE
GB2 N 1 1/4	35 MPa	32	93	46,5	115	75	13,5	111,5	98	300	120,5	24	N 1 1/4	88	60	17	32	6,975	GB2NNT63021A000	GB2NNT63044A000
GB2 N 1 1/2	35 MPa	40	107	53,5	131	85	13,5	125,5	113	300	134,5	25	N 1 1/2	102	75	17	40	7,393	GB2NNT73021A000	GB2NNT73044A000
GB2 N 2R	35 MPa	40	107	53,5	131	85	13,5	125,5	113	300	134,5	25	N 2	102	75	17	40	6,975	GB2NNR83021A000	GB2NNR83044A000
GB2 N 2	35 MPa	50	114	57	140	98	13,5	132,5	123	300	141,5	27	N 2	118	85	17	50	9,046	GB2NNT83021A000	GB2NNT83044A000

GB2 SAE J1926-1

Standard

TYPE	PN	DN	A	B	C	D	E	F	ØG	H	I	L	ØM	N	CH	SW	ØLW	KG	CARBON STEEL	STAINLESS STEEL
																			ITEM CODE	ITEM CODE
GB2 SAE20	35 MPa	32	93	46,5	115	75	13,5	111,5	98	300	120,5	24	1 5/8 UNF	88	60	17	32	6,975	GB2EEE53021A000	GB2EEE53044A000
GB2 SAE24	35 MPa	40	107	53,5	131	85	13,5	125,5	113	300	134,5	25	1 7/8 UNF	102	75	17	40	7,393	GB2EEE63021A000	GB2EEE63044A000
GB2 SAE32	35 MPa	50	114	57	140	98	13,5	132,5	123	300	141,5	27	2 1/2 UNF	118	85	17	50	9,046	GB2EEE73021A000	GB2EEE73044A000

+ GB2

2-WAY HIGH PRESSURE BALL VALVES

www.gemels.it

GB2

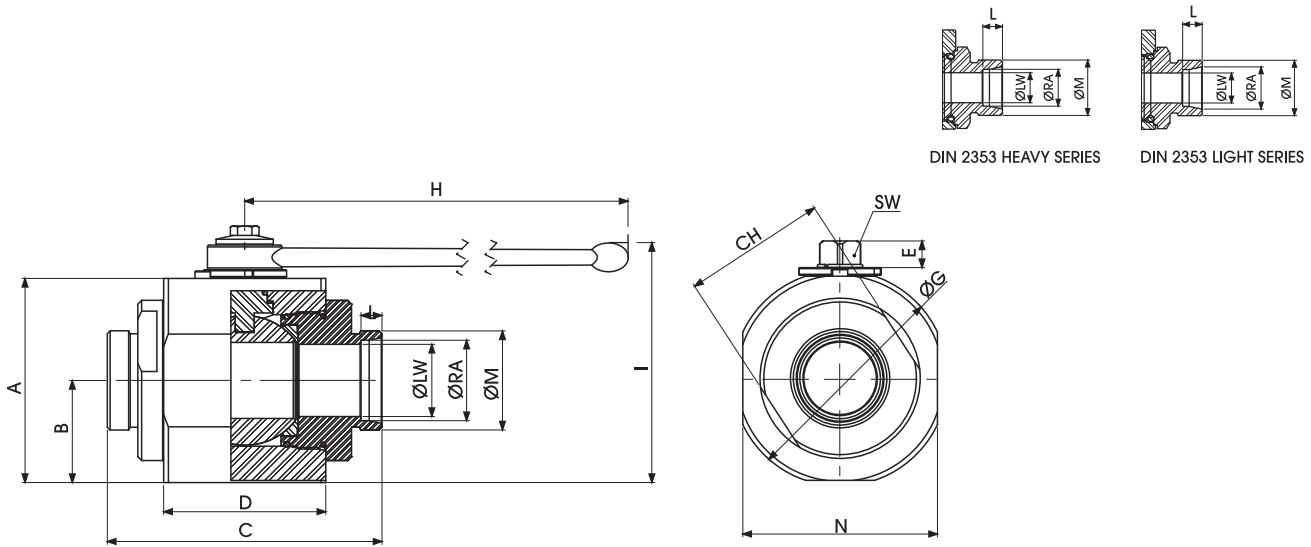

GB2 DIN 2353 HEAVY SERIES

Standard

TYPE	PN	DN	A	B	C	D	E	F	ØG	H	I	L	ØM	N	CH	SW	ØLW	ØRA	KG	CARBON STEEL	STAINLESS STEEL
																				ITEM CODE	ITEM CODE
GB2 38S	35 MPa	32	93	46,5	146	75	13,5	111,5	98	300	120,5	16	M52x2	88	60	17	32	38,3	5,229	GB2DDS93021A000	GB2DDS93044A000

GB2 DIN 2353 LIGHT SERIES

Standard

TYPE	PN	DN	A	B	C	D	E	F	ØG	H	I	L	ØM	N	CH	SW	ØLW	ØRA	KG	CARBON STEEL	STAINLESS STEEL
																				ITEM CODE	ITEM CODE
GB2 35L	35 MPa	32	93	46,5	135	75	13,5	111,5	98	300	120,5	10,5	M45x2	88	60	17	32	35,3	5,079	GB2DDLA3021A000	GB2DDLA3044A000
GB2 42L	35 MPa	40	107	53,5	144	85	13,5	125,5	113	300	134,5	11	M52x2	102	75	17	40	42,3	7,144	GB2DDL3021A000	GB2DDL3044A000

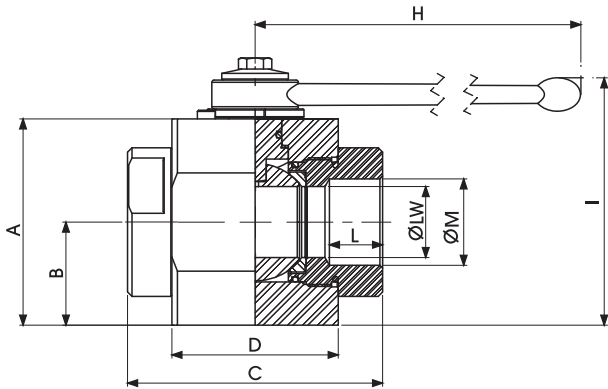
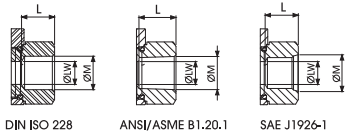

SECTION C-C
SCALE 1:1

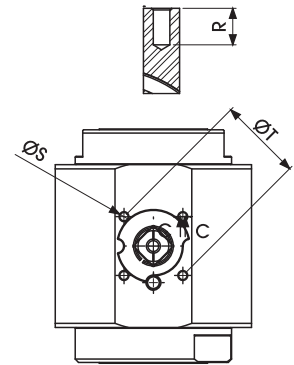

GB2 DIN/ISO 228 BSP

Fixing holes DIN/ISO5211

																				CARBON STEEL	STAINLESS STEEL	
TYPE	PN	DN	A	B	C	D	E	F	ØG	I	L	ØM	N	CH	R	ØS	ØT	SW	ØLW	KG	ITEM CODE	ITEM CODE
GB2 G 1 1/4	35 MPa	32	93	46,5	115	75	13,5	111,5	98	120,5	24	G 1 1/4	88	60	11	M6	50	17	32	6,975	GB2GGT63021AF50	GB2GGT63044AF50
GB2 G 1 1/2	35 MPa	40	107	53,5	131	85	13,5	125,5	113	134,5	25	G 1 1/2	102	75	11	M6	50	17	40	7,393	GB2GGT73021AF50	GB2GGT73044AF50
GB2 G 2R	35 MPa	40	107	53,5	131	85	13,5	125,5	113	134,5	25	G 2	102	75	11	M6	50	17	40	6,975	GB2GGR83021AF50	GB2GGR83044AF50
GB2 G 2	35 MPa	50	114	57	140	98	13,5	132,5	123	141,5	27	G 2	118	85	11	M6	50	17	50	9,046	GB2GGT83021AF50	GB2GGT83044AF50

GB2 ANSI/ASME B1.20.1 NPT

Fixing holes DIN/ISO5211

																				CARBON STEEL	STAINLESS STEEL	
TYPE	PN	DN	A	B	C	D	E	F	ØG	I	L	ØM	N	CH	R	ØS	ØT	SW	ØLW	KG	ITEM CODE	ITEM CODE
GB2 N 1 1/4	35 MPa	32	93	46,5	115	75	13,5	111,5	98	120,5	24	N 1 1/4	88	60	11	M6	50	17	32	6,975	GB2NNT63021AF50	GB2NNT63044AF50
GB2 N 1 1/2	35 MPa	40	107	53,5	131	85	13,5	125,5	113	134,5	25	N 1 1/2	102	75	11	M6	50	17	40	7,393	GB2NNT73021AF50	GB2NNT73044AF50
GB2 N 2R	35 MPa	40	107	53,5	131	85	13,5	125,5	113	134,5	25	N 2	102	75	11	M6	50	17	40	6,975	GB2NNR83021AF50	GB2NNR83044AF50
GB2 N 2	35 MPa	50	114	57	140	98	13,5	132,5	123	141,5	27	N 2	118	85	11	M6	50	17	50	9,046	GB2NNT83021AF50	GB2NNT83044AF50

GB2 SAE J1926-1

Fixing holes DIN/ISO5211

																				CARBON STEEL	STAINLESS STEEL	
TYPE	PN	DN	A	B	C	D	E	F	ØG	I	L	ØM	N	CH	R	ØS	ØT	SW	ØLW	KG	ITEM CODE	ITEM CODE
GB2 SAE20	35 MPa	32	93	46,5	115	75	13,5	111,5	98	120,5	24	1 5/8 UNF	88	60	11	M6	50	17	32	6,975	GB2EEE53021AF50	GB2EEE53044AF50
GB2 SAE24	35 MPa	40	107	53,5	131	85	13,5	125,5	113	134,5	25	1 7/8 UNF	102	75	11	M6	50	17	40	7,393	GB2EEE63021AF50	GB2EEE63044AF50
GB2 SAE32	35 MPa	50	114	57	140	98	13,5	132,5	123	141,5	300	2 1/2 UNF	118	85	11	M6	50	17	50	9,046	GB2EEE73021AF50	GB2EEE73044AF50

+ GB2

2-WAY HIGH PRESSURE BALL VALVES

www.gemels.it

GB2

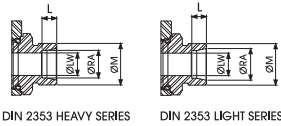

SECTION A-A
SCALE 1:1.7

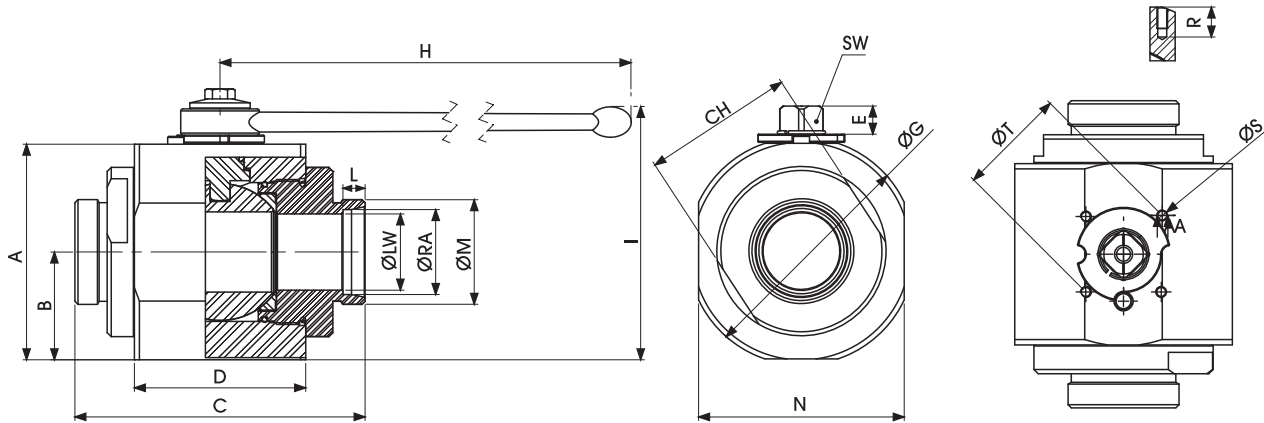

GB2 DIN 2353 HEAVY SERIES

Fixing holes DIN/ISO5211

CARBON STEEL STAINLESS STEEL

TYPE	PN	DN	A	B	C	D	E	F	ØG	I	L	ØM	N	CH	R	ØS	ØT	SW	ØLW	ØRA	KG	ITEM CODE	ITEM CODE
GB2 38S	35 MPa	32	93	46,5	146	75	13,5	111,5	98	120,5	16	M52x2	88	60	11	M6	50	17	32	38,3	5,229	GB2DDS93021AF50	GB2DDS93044AF50

GB2 DIN 2353 LIGHT SERIES

Fixing holes DIN/ISO5211

CARBON STEEL STAINLESS STEEL

TYPE	PN	DN	A	B	C	D	E	F	ØG	I	L	ØM	N	CH	R	ØS	ØT	SW	ØLW	ØRA	KG	ITEM CODE	ITEM CODE
GB2 35L	35 MPa	32	93	46,5	135	75	13,5	111,5	98	120,5	10,5	M45x2	88	60	11	M6	50	17	32	35,3	5,079	GB2DDLA3021AF50	GB2DDLA3044AF50
GB2 42L	35 MPa	40	107	53,5	144	85	13,5	125,5	113	134,5	11	M52x2	102	75	11	M6	50	17	40	42,3	7,144	GB2DDL3021AF50	GB2DDL3044AF50

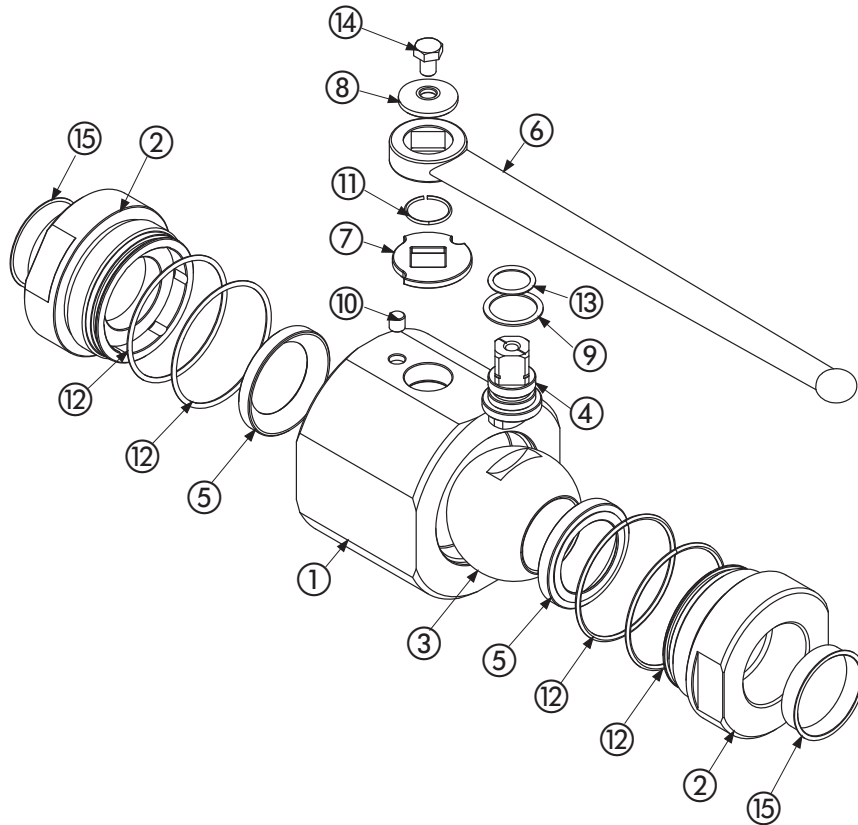

Carbon steel

Pos	Description	Material	Q.tà
1	Body	1,0570	1
2	Adapter	1,0570	2
3	Ball	1,0737	1
4	Stem	1,0737	1
5	Ball seat	POM	2
6	Handle	1,0116	1
7	Washer	1,0116	1
8	Washer	1,0737	1
9	Stem ring	POM	1
10	Spine	1,0737	1
11	Seeger	1,4301	1
12	Adapter o-ring	NBR	4
13	Stem o-ring	NBR	1
14	Screw	ISO4017 8.8	1
15	Caps	PVC	2

On request

- Reduced bore
- O-Ring in FKM, EPDM, HNBR, KALREZ
- Seals in PTFE, PEEK, PA612, GEMPTFE, METAL TO METAL
- Special threads
- Stem in stainless steel 1,4404
- Ball in stainless steel 1,4404
- Pressure class up to PN35 MPa
- Pneumatic and electrical actuator
- Security block
- Locking device

Stainless steel

Pos	Description	Material	Q.tà
1	Body	1,4044	1
2	Adapter	1,4044	2
3	Ball	1,4044	1
4	Stem	1,4301	1
5	Ball seat	POM	2
6	Handle	1,4031	1
7	Washer	1,4031	1
8	Washer	1,4031	1
9	Stem ring	POM	1
10	Spine	1,4301	1
11	Seeger	1,4301	1
12	Adapter o-ring	NBR	4
13	Stem o-ring	NBR	1
14	Screw	ISO4017 A2	1
15	Caps	PVC	2

On request

- Reduced bore
- O-Ring in FKM, EPDM, HNBR, KALREZ
- Seals in PTFE, PEEK, PA612, GEMPTFE, METAL TO METAL
- Special threads
- Pressure class up to PN35 MPa
- Pneumatic and electrical actuator
- Security block
- Locking device

For further special requests please consult our technical/commercial service

+ GB3

3-WAY HIGH PRESSURE BALL VALVES

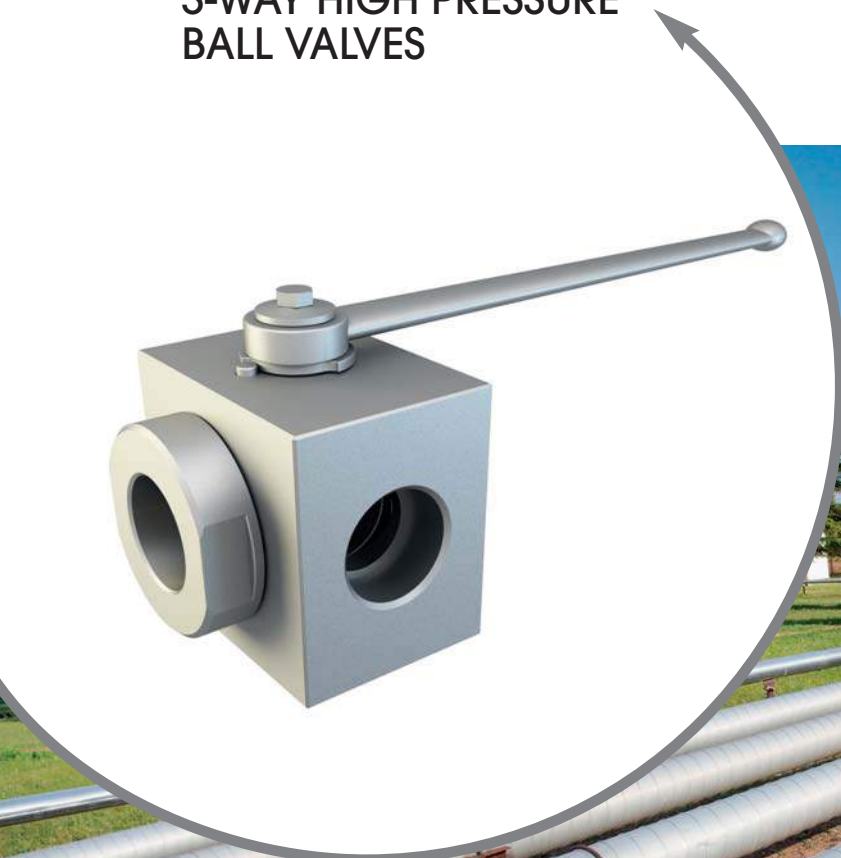

CARBON STEEL

- Type: ball valve GB 3 way
- Body: square
- Material: 1,0570/1,0737
- Ball seats: from DN32 up to DN50
- O-Rings: NBR, FKM, EPDM, MVQ
- Operating pressure: 350 Bar depending on valve size and seal materials selected
- Temp range: -20°C to +100°C depending on seal material selected

GB3	G 1 1/2		DN40	2	2	1	1	A	B
Type and way of valve	GAS DIN/ISO 228 BSP	NPT ANSI/ASME B1.20.1	Nominal dimension	Body material	Adapter material	Stem material	Ball material	Ball seat material	Adapter and stem seal material
GB3 3-way	G 1 1/4	N 1 1/4	DN32	2 1,0570	2 1,0570	1 1,0737	1 1,0737	A POM D PEEK G PA612 K GEMPTFE C PTFE	B NBR E FKM F EPDM L MVQ

STAINLESS STEEL

- Type: ball valve GB 3 way
- Body: square
- Material: 1,4404/1,4404
- Ball seats: from DN32 up to DN50
- O-Rings: NBR, FKM, EPDM, MVQ
- Operating pressure: 350 Bar depending on valve size and seal materials selected
- Temp range: -30°C to +100°C different temperatures on request

GB3	G 1 1/2		DN40	4	4	4	4	A	B
Type and way of valve	GAS DIN/ISO 228 BSP	NPT ANSI/ASME B1.20.1	Nominal dimension	Body material	Adapter material	Stem material	Ball material	Ball seat material	Adapter and stem seal material
GB3 3-way	G 1 1/4	N 1 1/4	DN32	4 1,4404	4 1,4404	4 1,4404	4 1,4404	A POM D PEEK G PA612 K GEMPTFE C PTFE	B NBR E FKM F EPDM L MVQ

"The company reserves the right to operate dimensional changes without prior notice".

+ GB3

3-WAY HIGH PRESSURE BALL VALVES

Specialist in Ball Valves

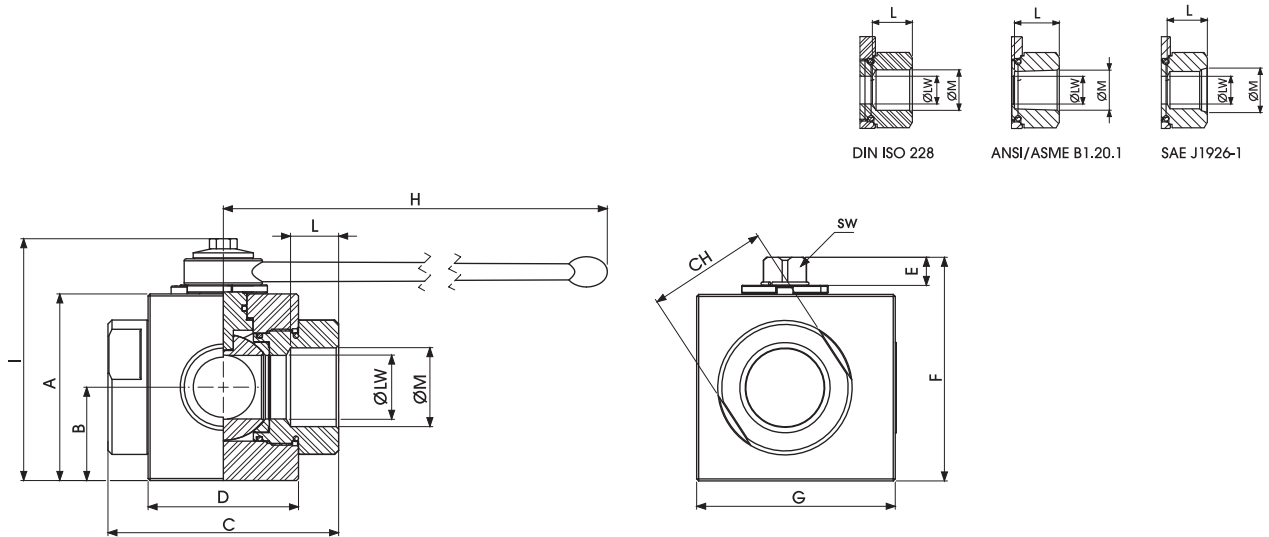

GB3 DIN/ISO 228 BSP

Standard

																	CARBON STEEL	STAINLESS STEEL	
TYPE	PN	DN	A	B	C	D	E	F	G	H	I	L	ØM	CH	SW	ØLW	KG	ITEM CODE	ITEM CODE
GB3 G 1 1/4	35 MPa	32	93	46,5	115	75	13,5	111,5	99	300	120,5	24	G 1 1/4	60	17	32	5,725	GB3GGT63021A000	GB3GGT63044A000
GB3 G 1 1/2	35 MPa	40	107	53,5	131	85	13,5	125,5	115	300	134,5	25	G 1 1/2	75	17	40	8,632	GB3GGT73021A000	GB3GGT73044A000
GB3 G 2	35 MPa	50	114	57	140	98	13,5	132,5	128	300	141,5	27	G 2	85	17	50	10,607	GB3GGT83021A000	GB3GGT83044A000

GB3 ANSI/ASME B1.20.1 NPT

Standard

																	CARBON STEEL	STAINLESS STEEL	
TYPE	PN	DN	A	B	C	D	E	F	G	H	I	L	ØM	CH	SW	ØLW	KG	ITEM CODE	ITEM CODE
GB3 N 1 1/4	35 MPa	32	93	46,5	115	75	13,5	111,5	99	300	120,5	24	N 1 1/4	60	17	32	5,725	GB3NNT63021A000	GB3NNT63044A000
GB3 N 1 1/2	35 MPa	40	107	53,5	131	85	13,5	125,5	115	300	134,5	25	N 1 1/2	75	17	40	8,632	GB3NNT73021A000	GB3NNT73044A000
GB3 N 2	35 MPa	50	114	57	140	98	13,5	132,5	128	300	141,5	27	N 2	85	17	50	10,607	GB3NNT83021A000	GB3NNT83044A000

+ GB3

3-WAY HIGH PRESSURE BALL VALVES

www.gemels.it

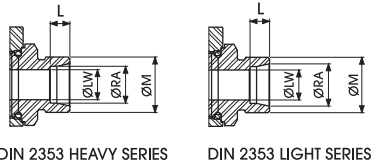

SECTION A-A
SCALE 1:1

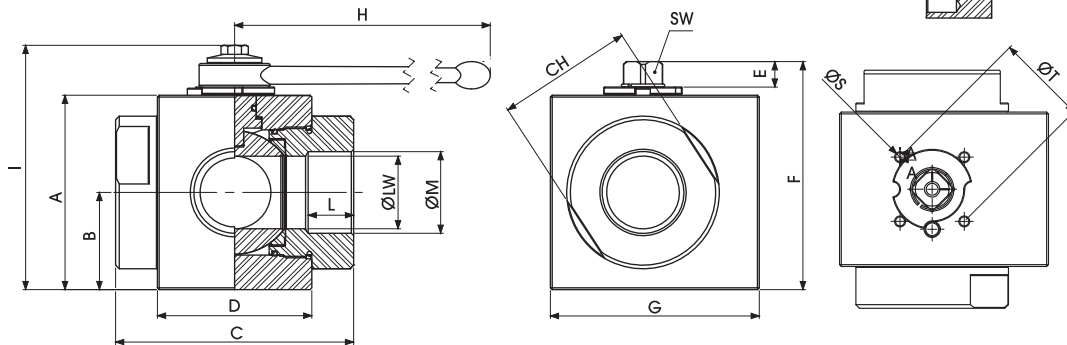

GB3 DIN/ISO 228 BSP

fixing hole

																					CARBON STEEL	STAINLESS STEEL	
TYPE	PN	DN	A	B	C	D	E	F	G	H	I	L	ØM	CH	R	ØS	ØT	ISO5211	SW	ØLW	KG	ITEM CODE	ITEM CODE
GB3 G 1 1/4	35 MPa	32	93	46,5	115	75	13,5	111,5	99	300	120,5	24	G 1 1/4	60	11	M6	50	F05	17	32	5,725	GB3GGT63021AF50	GB3GGT63044AF50
GB3 G 1 1/2	35 MPa	40	107	53,5	131	85	13,5	125,5	115	300	134,5	25	G 1 1/2	75	11	M6	50	F05	17	40	8,632	GB3GGT73021AF50	GB3GGT73044AF50
GB3 G 2	35 MPa	50	114	57	140	98	13,5	132,5	128	300	141,5	27	G 2	85	11	M6	50	F05	17	50	10,607	GB3GGT83021AF50	GB3GGT83044AF50

GB3 ANSI/ASME B1.20.1 NPT

fixing hole

																					CARBON STEEL	STAINLESS STEEL	
TYPE	PN	DN	A	B	C	D	E	F	G	H	I	L	ØM	CH	R	ØS	ØT	ISO5211	SW	ØLW	KG	ITEM CODE	ITEM CODE
GB3 N 1 1/4	35 MPa	32	93	46,5	115	75	13,5	111,5	99	300	120,5	24	N 1 1/4	60	11	M6	50	F05	17	32	5,725	GB3NNT63021AF50	GB3NNT63044AF50
GB3 N 1 1/2	35 MPa	40	107	53,5	131	85	13,5	125,5	115	300	134,5	25	N 1 1/2	75	11	M6	50	F05	17	40	8,632	GB3NNT73021AF50	GB3NNT73044AF50
GB3 N 2	35 MPa	50	114	57	140	98	13,5	132,5	128	300	141,5	27	N 2	85	11	M6	50	F05	17	50	10,607	GB3NNT83021AF50	GB3NNT83044AF50

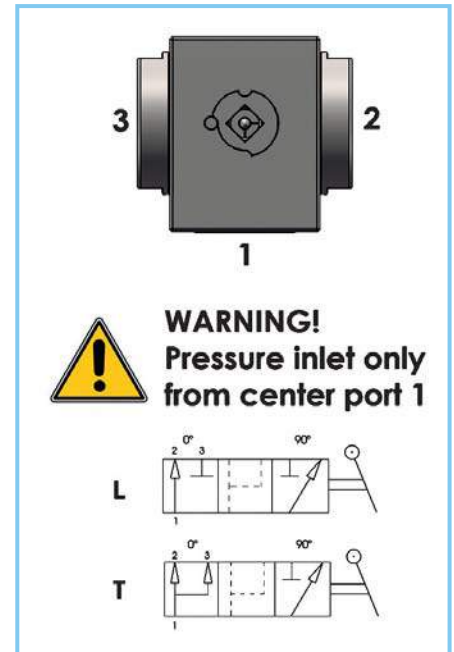
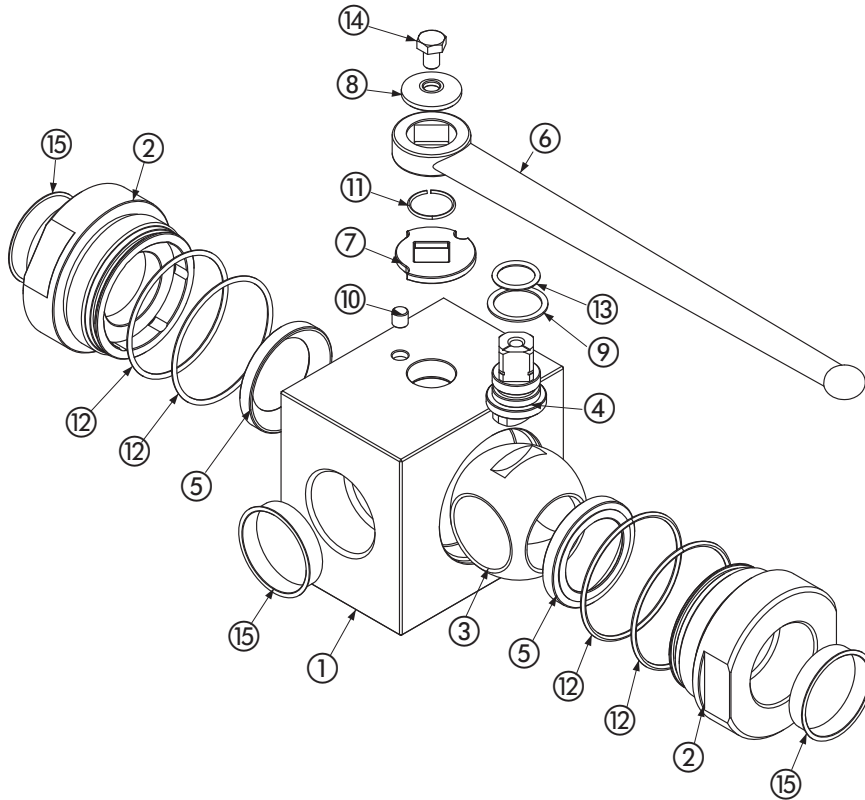

Carbon steel			
Pos	Description	Material	Q.tà
1	Body	1,0570	1
2	Adapter	1,0570	2
3	Ball	1,0737	1
4	Stem	1,0737	1
5	Ball seat	POM	2
6	Handle	1,0116	1
7	Washer	1,0116	1
8	Washer	1,0116	1
9	Stem ring	POM	1
10	Spine	1,0737	1
11	Seeger	1,4301	1
12	Adapter o-ring	NBR	4
13	Stem o-ring	NBR	1
14	Screw	ISO4017 8.8	1
15	Caps	PVC	3

Stainless steel			
Pos	Description	Material	Q.tà
1	Body	1,4404	1
2	Adapter	1,4404	2
3	Ball	1,4404	1
4	Stem	1,4404	1
5	Ball seat	POM	2
6	Handle	1,4301	1
7	Washer	1,4301	1
8	Washer	1,4301	1
9	Stem ring	POM	1
10	Spine	1,4301	1
11	Seeger	1,4301	1
12	Adapter o-ring	NBR	4
13	Stem o-ring	NBR	1
14	Screw	ISO4017 A2	1
15	Caps	PVC	3

For further special requests please consult our technical/commercial service

- On request**
- Reduced bore
 - O-Ring in FKM, EPDM, HNBR, KALREZ
 - Seals in PTFE, PEEK, PA612, GEMPTFE, METAL TO METAL
 - Special threads
 - Stem in stainless steel 1,4404
 - Ball in stainless steel 1,4404
 - Pressure class up to PN35 MPa
 - Pneumatic and electrical actuator
 - Locking device

- On request**
- Reduced bore
 - O-Ring in FKM, EPDM, HNBR, KALREZ
 - Seals in PTFE, PEEK, PA612, GEMPTFE, METAL TO METAL
 - Special threads
 - Pressure class up to PN35 MPa
 - Pneumatic and electrical actuator
 - Locking device

+ GBF

2-WAY HIGH PRESSURE BALL VALVES



CARBON STEEL

- Type: ball valve GB 2 way
- Body: round
- Material: 1,0570/1,0737
- Ball seats: from DN32 up to DN50
- O-Rings: NBR, FKM, EPDM, MVQ
- Operating pressure: S3000 (210 bar), S6000 (350 bar) depending on valve size and seal materials selected
- Temp range: -20°C to +100°C depending on seal material selected

GB	F3	DN32	2	2	1	1	A	B
Type and way of valve GB 2-way	Valves dimension of pressure (psi) F3 F6	Nominal dimension	Body material	Adapter material	Stem material	Ball material	Ball seat material	Adapter and stem seal material
	S3000 S6000	DN32 DN40 DN50	2 1,0570	2 1,0570	1 1,0737	1 1,0737	A POM D PEEK G PA612 K GEMPTFE C PTFE	B NBR E FKM F EPDM L MVQ

STAINLESS STEEL

- Type: ball valve GB 2 way
- Body: round
- Material: 1,4404/1,4404
- Ball seats: from DN32 up to DN50
- O-Rings: NBR, FKM, EPDM, MVQ
- Operating pressure: S3000 (210 bar), S6000 (350 bar) depending on valve size and seal materials selected
- Temp range: -30°C to +100°C different temperatures on request

GB	F3	DN32	4	4	4	4	A	B
Type and way of valve GB 2-way	Valves dimension of pressure (psi) F3 F6	Nominal dimension	Body material	Adapter material	Stem material	Ball material	Ball seat material	Adapter and stem seal material
	S3000 S6000	DN32 DN40 DN50	4 1,4404	4 1,4404	4 1,4404	4 1,4404	A POM D PEEK G PA612 K GEMPTFE C PTFE	B NBR E FKM F EPDM L MVQ

"The company reserves the right to operate dimensional changes without prior notice".



2-WAY HIGH PRESSURE BALL VALVES

Specialist in Ball Valves

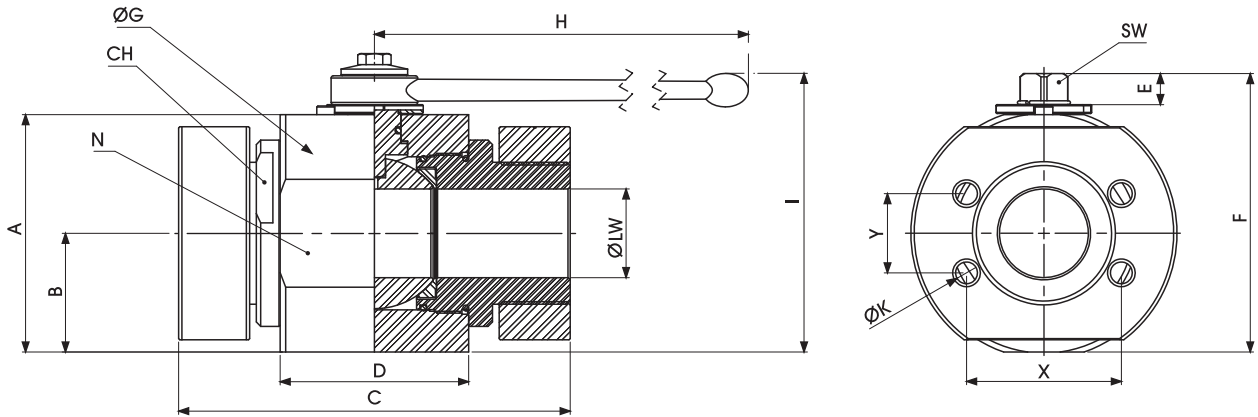

GBF SAE J518 S3000

Standard

TYPE	PN	DN	A	B	C	D	E	F	ØG	H	I	N	X	Y	ØK	CH	SW	ØLW	KG	CARBON STEEL	STAINLESS STEEL
																				ITEM CODE	ITEM CODE
GBF3	4000 Psi	32	93	46,5	172	75	13,5	111,5	98	300	120,5	88	58,7	30,2	M10	60	17	32	8,102	GB2FFC3L021A000	GB2FFC3L044A000
GBF3	3000 Psi	40	107	53,5	176,5	85	13,5	125,5	113	300	134,5	102	69,8	35,7	M12	75	17	40	11,142	GB2FFC4L021A000	GB2FFC4L044A000
GBF3	3000 Psi	50	114	57	196	98	13,5	132,5	123	300	141,5	118	77,8	42,9	M12	85	17	50	15,343	GB2FFC5L021A000	GB2FFC5L044A000

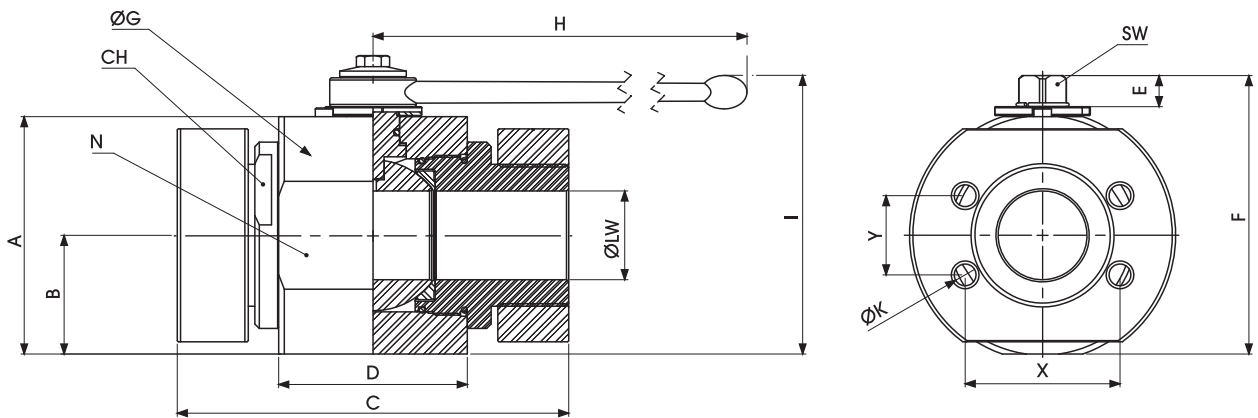

GBF SAE J518 S3000 UNC

Standard

TYPE	PN	DN	A	B	C	D	E	F	ØG	H	I	N	X	Y	ØK	CH	SW	ØLW	KG	CARBON STEEL	STAINLESS STEEL
																				ITEM CODE	ITEM CODE
GBF3	4000 Psi	32	93	46,5	172	75	13,5	111,5	98	300	120,5	88	58,7	30,2	7/16-14 UNC	60	17	32	8,102	GB2FUC3L021A000	GB2FUC3L044A000
GBF3	3000 Psi	40	107	53,5	176,5	85	13,5	125,5	113	300	134,5	102	69,8	35,7	1/2-13 UNC	75	17	40	11,142	GB2FUC4L021A000	GB2FUC4L044A000
GBF3	3000 Psi	50	114	57	196	98	13,5	132,5	123	300	141,5	118	77,8	42,9	1/2-13 UNC	85	17	50	15,343	GB2FUC5L021A000	GB2FUC5L044A000

"The company reserves the right to operate dimensional changes without prior notice".

+ GBF

2-WAY HIGH PRESSURE BALL VALVES

www.gemels.it

GBF

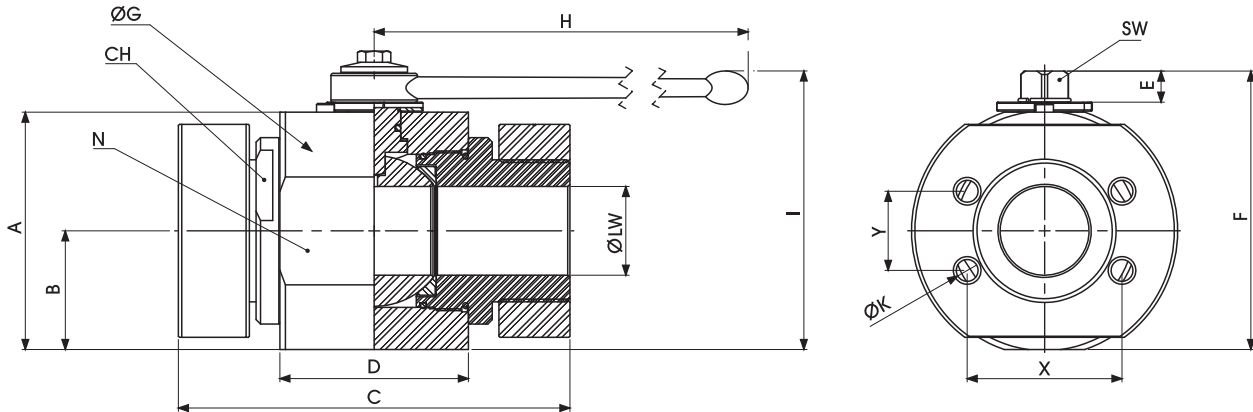

GBF SAE J518 S6000

Standard

TYPE	PN	DN	A	B	C	D	E	F	ØG	H	I	N	X	Y	ØK	CH	SW	ØLW	KG	CARBON STEEL	STAINLESS STEEL
																				ITEM CODE	ITEM CODE
GBF6	5000 Psi	32	93	46,5	172	75	13,5	111,5	98	300	120,5	88	66,7	31,8	M12	60	17	32	8,102	GB2FFC93021A000	GB2FFC93044A000
GBF6	5000 Psi	40	107	53,5	176,5	85	13,5	125,5	113	300	134,5	102	79,4	36,5	M16	75	17	40	11,142	GB2FFCA3021A000	GB2FFCA3044A000
GBF6	5000 Psi	50	114	57	196	98	13,5	132,5	123	300	141,5	118	96,8	44,5	M20	80	17	50	15,343	GB2FFCB3021A000	GB2FFCB3044A000

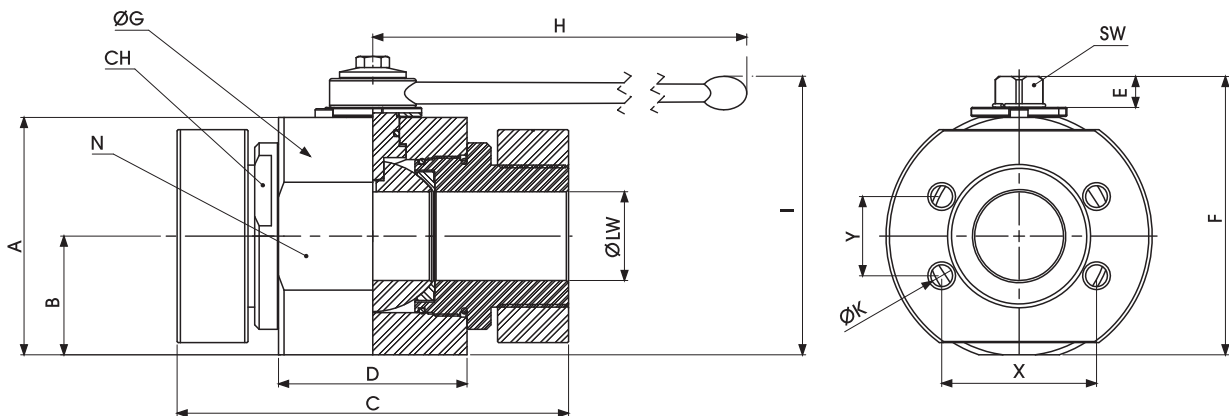

GBF SAE J518 S6000 UNC

Standard

TYPE	PN	DN	A	B	C	D	E	F	ØG	H	I	N	X	Y	ØK	CH	SW	ØLW	KG	CARBON STEEL	STAINLESS STEEL
																				ITEM CODE	ITEM CODE
GBF6	5000 Psi	32	93	46,5	172	75	13,5	111,5	98	300	120,5	88	66,7	31,8	1/2-13 UNC	60	17	32	8,102	GB2FUC93021A000	GB2FUC93044A000
GBF6	5000 Psi	40	107	53,5	176,5	85	13,5	125,5	113	300	134,5	102	79,4	36,5	5/8-11 UNC	75	17	40	11,142	GB2FUCA3021A000	GB2FUCA3044A000
GBF6	5000 Psi	50	114	57	196	98	13,5	132,5	123	300	141,5	118	96,8	44,5	3/4-10 UNC	85	17	50	15,343	GB2FUCB3021A000	GB2FUCB3044A000

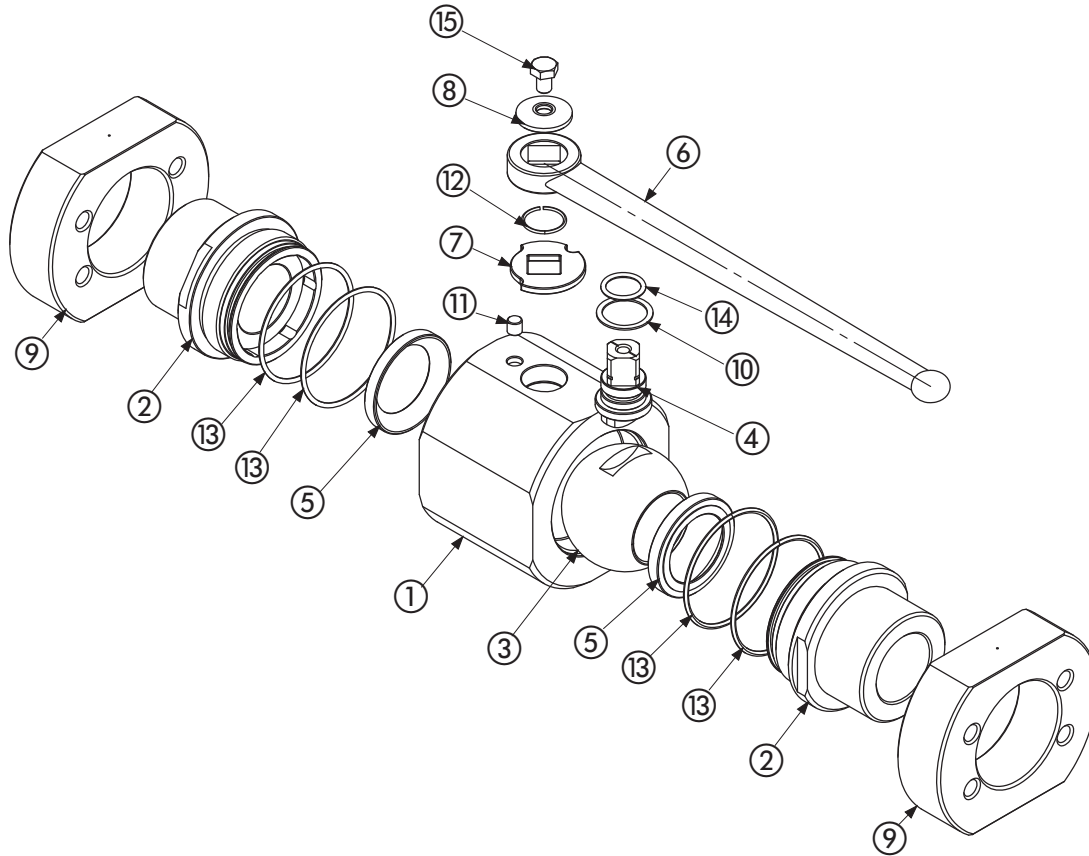

Carbon steel

Pos	Description	Material	Q.tà
1	Body	1,0570	1
2	Adapter	1,0570	2
3	Ball	1,0737	1
4	Stem	1,0737	1
5	Ball seat	POM	2
6	Handle	1,0116	1
7	Washer	1,0116	1
8	Washer	1,0737	1
9	Flange	1,0570	2
10	Stem ring	POM	1
11	Spine	1,0737	1
12	Seeger	1,4301	1
13	Adapter o-ring	NBR	4
14	Stem o-ring	NBR	1
15	Screw	ISO4017 8.8	1

On request

- Reduced bore
- O-Ring in FKM, EPDM, HNBR, KALREZ
- Seals in PTFE, PEEK, PA612, GEMPTFE, METAL TO METAL
- Special threads
- Stem in stainless steel 1,4404
- Ball in stainless steel 1,4404
- Pressure class up to PN5000 Psi
- Pneumatic and electrical actuator
- Locking device

Stainless steel

Pos	Description	Material	Q.tà
1	Body	1,4044	1
2	Adapter	1,4044	2
3	Ball	1,4044	1
4	Stem	1,4301	1
5	Ball seat	POM	2
6	Handle	1,4301	1
7	Washer	1,4301	1
8	Washer	1,4301	1
9	Flange	1,4044	2
10	Stem ring	POM	1
11	Spine	1,4301	1
12	Seeger	1,4301	1
13	Adapter o-ring	NBR	4
14	Stem o-ring	NBR	1
15	Screw	ISO4017 A2	1

On request

- Reduced bore
- O-Ring in FKM, EPDM, HNBR, KALREZ
- Seals in PTFE, PEEK, PA612, GEMPTFE, METAL TO METAL
- Special threads
- Pressure class up to PN5000 Psi
- Pneumatic and electrical actuator
- Locking device

For further special requests please consult our technical/commercial service

+ GBS

2-WAY HIGH PRESSURE BALL VALVES



CARBON STEEL

- Type: ball valve GB 2 way
- Body: round
- Material: 1,0570/1,0737
- Ball seats: from DN32 up to DN50
- O-Rings: NBR, FKM, EPDM, MVQ
- Operating pressure: S3000 (210 bar), S6000 (350 bar) depending on valve size and seal materials selected
- Temp range: -20°C to +100°C depending on seal material selected

GB	S3	DN32	2	2	1	1	A	B
Type and way of valve GB 2-way	Valves dimension of pressure (psi) S3 S6	Nominal dimension DN32 DN40 DN50	Body material 2 1,0570	Adapter material 2 1,0570	Stem material 1 1,0737	Ball material 1 1,0737	Ball seat material A POM D PEEK G PA612 K GEMPTFE C PTFE	Adapter and stem seal material B NBR E FKM F EPDM L MVQ

STAINLESS STEEL

- Type: ball valve GB 2 way
- Body: round
- Material: 1,4404/1,4404
- Ball seats: from DN32 up to DN50
- O-Rings: NBR, FKM, EPDM, MVQ
- Operating pressure: S3000 (210 bar), S6000 (350 bar) depending on valve size and seal materials selected
- Temp range: -30°C to +100°C different temperatures on request

GB	S3	DN32	4	4	4	4	A	B
Type and way of valve GB 2-way	Valves dimension of pressure (psi) S3 S6	Nominal dimension DN32 DN40 DN50	Body material 4 1,4404	Adapter material 4 1,4404	Stem material 4 1,4404	Ball material 4 1,4404	Ball seat material A POM D PEEK G PA612 K GEMPTFE C PTFE	Adapter and stem seal material B NBR E FKM F EPDM L MVQ

"The company reserves the right to operate dimensional changes without prior notice".



2-WAY HIGH PRESSURE BALL VALVES

Specialist in Ball Valves

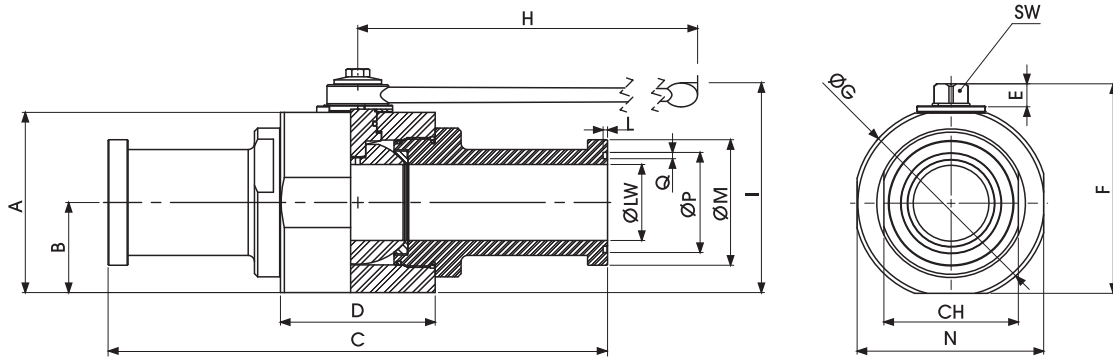

GBS SAE J518 S3000

Standard

																				CARBON STEEL	STAINLESS STEEL	
TYPE	PN	DN	A	B	C	D	E	F	ØG	H	I	L	ØM	N	CH	ØP	Q	SW	ØLW	KG	ITEM CODE	ITEM CODE
GBS3	4000 Psi	32	93	46,5	190,5	75	13,5	111,5	98	300	120,5	2,79	50,8	88	60	44,45	3,94	17	32	5,429	GB2SSC3L021A000	GB2SSC3L044A000
GBS3	3000 Psi	40	107	53,5	230,5	85	13,5	125,5	113	300	134,5	2,79	60,26	102	75	53,67	3,94	17	40	8,265	GB2SSC4L021A000	GB2SSC4L044A000
GBS3	3000 Psi	50	114	57	232	98	13,5	132,5	123	300	141,5	2,79	71,4	118	85	63,25	3,94	17	50	9,865	GB2SSC5L021A000	GB2SSC5L044A000

"The company reserves the right to operate dimensional changes without prior notice".

+ GBS

2-WAY HIGH PRESSURE BALL VALVES

www.gemels.it

GBS

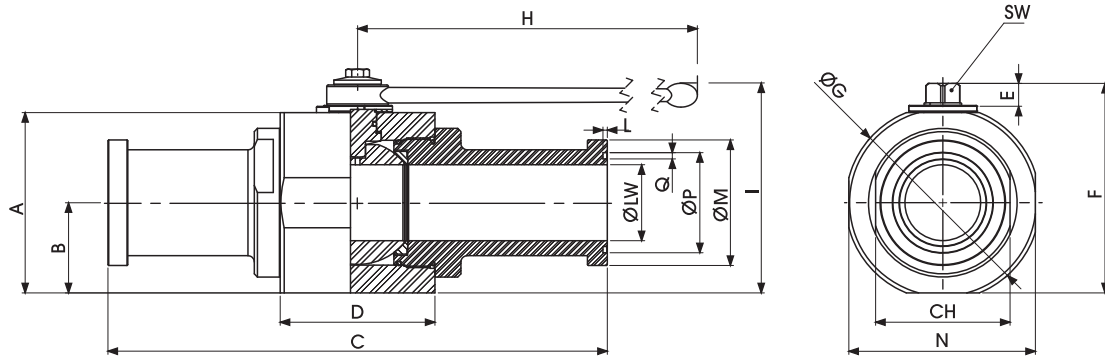

GBS SAE J518 S6000

Standard

TYPE	PN	DN	A	B	C	D	E	F	ØG	H	I	L	ØM	N	CH	ØP	Q	SW	ØLW	KG	CARBON STEEL	STAINLESS STEEL
																					ITEM CODE	ITEM CODE
GBS6	5000 Psi	32	93	46,5	223	75	13,5	111,5	98	300	120,5	2,79	54	88	60	44,45	3,94	17	32	5,828	GB2SSC93021A000	GB2SSC93044A000
GBS6	5000 Psi	40	107	53,5	281	85	13,5	125,5	113	300	134,5	2,79	63,46	102	75	53,67	3,94	17	40	8,251	GB2SSCA3021A000	GB2SSCA3044A000
GBS6	5000 Psi	50	114	57	316	98	13,5	132,5	123	300	141,5	2,79	79,4	118	85	63,25	3,94	17	50	11,774	GB2SSCB3021A000	GB2SSCB3044A000

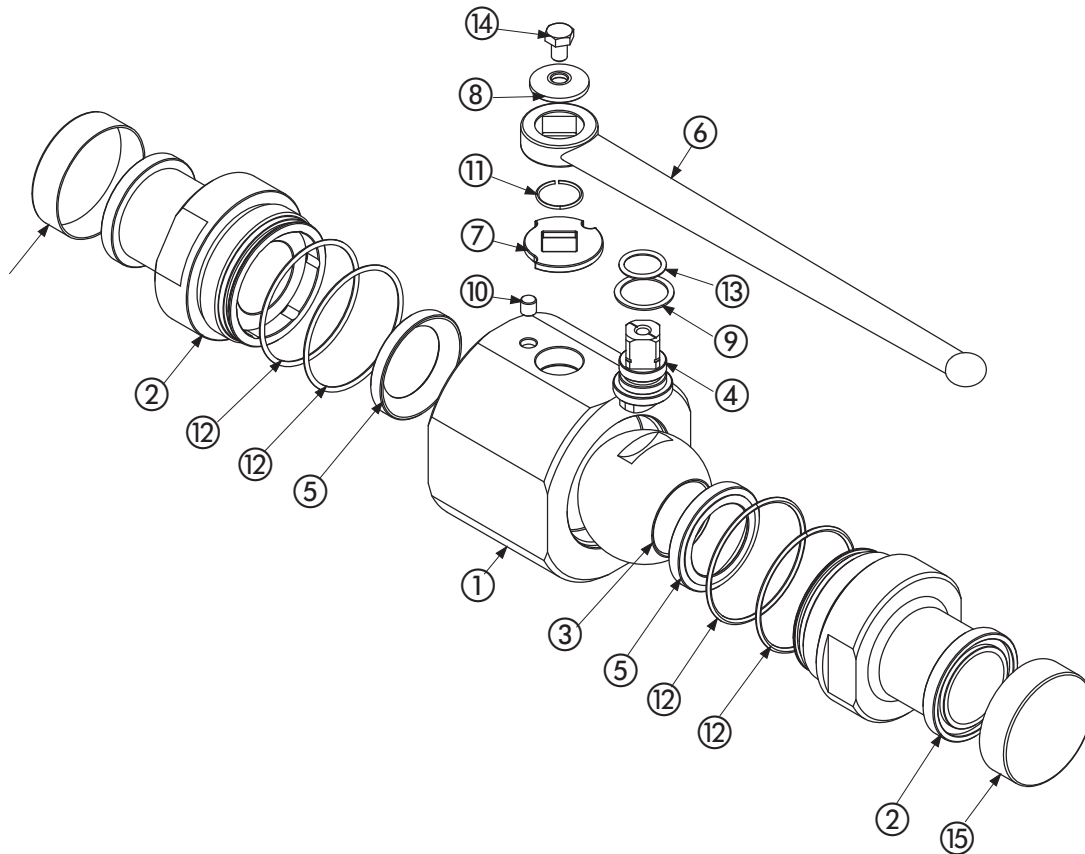

Carbon steel

Pos	Description	Material	Q.tà
1	Body	1,0570	1
2	Adapter	1,0570	2
3	Ball	1,0737	1
4	Stem	1,0737	1
5	Ball seat	POM	2
6	Handle	1,0116	1
7	Washer	1,0116	1
8	Washer	1,0737	1
9	Stem ring	POM	1
10	Spine	1,0737	1
11	Seeger	1,4301	1
12	Adapter o-ring	NBR	4
13	Stem o-ring	NBR	1
14	Screw	ISO4017 8.8	1
15	Caps	PVC	2

- On request**
- Reduced bore
 - O-Ring in FKM, EPDM, HNBR, KALREZ
 - Seals in PTFE, PEEK, PA612, GEMPTFE, METAL TO METAL
 - Special threads
 - Stem in stainless steel 1,4404
 - Ball in stainless steel 1,4404
 - Pressure class up to PN5000 Psi
 - Pneumatic and electrical actuator
 - Locking device
 - Cut and uncut flange S3000-S6000

For further special requests please consult our technical/commercial service

Stainless steel

Pos	Description	Material	Q.tà
1	Body	1,4404	1
2	Adapter	1,4404	2
3	Ball	1,4404	1
4	Stem	1,4404	1
5	Ball seat	POM	2
6	Handle	1,4301	1
7	Washer	1,4301	1
8	Washer	1,4301	1
9	Stem ring	POM	1
10	Spine	1,4301	1
11	Seeger	1,4301	1
12	Adapter o-ring	NBR	4
13	Stem o-ring	NBR	1
14	Screw	ISO4017 A2	1
15	Caps	PVC	2

- On request**
- Reduced bore
 - O-Ring in FKM, EPDM, HNBR, KALREZ
 - Seals in PTFE, PEEK, PA612, GEMPTFE, METAL TO METAL
 - Special threads
 - Pressure class up to PN5000 Psi
 - Pneumatic and electrical actuator
 - Locking device
 - Cut and uncut flange S3000-S6000

+ GBC

2-WAY HIGH PRESSURE BALL VALVES



CARBON STEEL

- Type: ball valve GBC 2 way
- Body: round
- Material: 1,0570/1,0737
- Ball seats: from DN32 up to DN50
- O-Rings: NBR, FKM, EPDM, MVQ
- Operating pressure: 350 Bar depending on valve size and seal materials selected
- Temp range: -20°C to +100°C depending on seal material selected

GBC	SAE32 M	DN32	1	1	1	1	A	B		
Type and way of valve	Valves dimension of pressure (psi)			Nominal dimension	Body material	Adapter material	Stem material	Ball material	Ball seat material	Adapter and stem seal material
GBC 2-way	MALE	FEMALE	MALE-FEMALE							
	SAE20	SAE20	SAE20	DN32	2 1,0570	2 1,0570	1 1,0737	1 1,0737	A POM	B NBR
	SAE24	SAE24	SAE24	DN40					D PEEK	E FKM
	SAE32	SAE32	SAE32	DN50					G PA612	F EPDM
									K GEMPTFE	L MVQ
									C PTFE	



2-WAY HIGH PRESSURE BALL VALVES

Specialist in Ball Valves

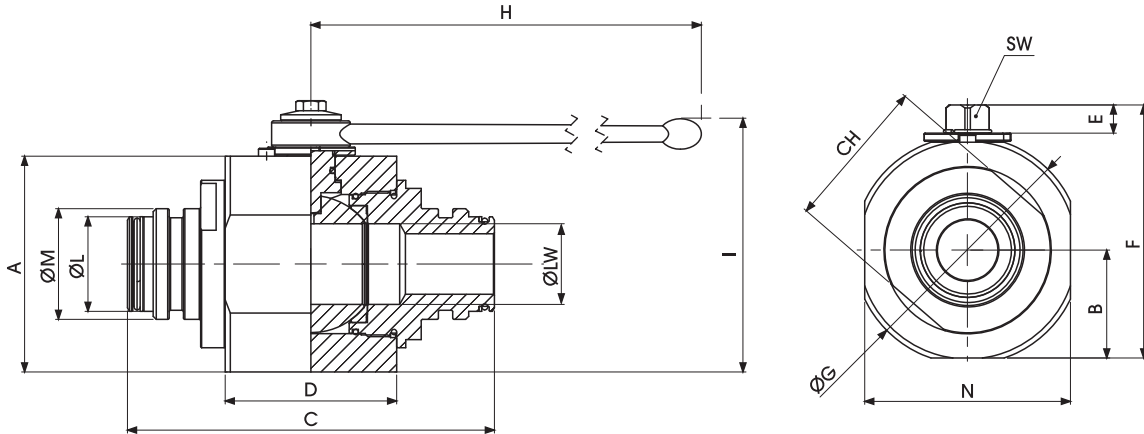

GBC MALE SAEJ1467

Standard

CARBON STEEL

TYPE	PN	DN	A	B	C	D	E	F	ØG	H	I	ØL	ØM	N	CH	SW	ØLW	KG	ITEM CODE
GBC SAE20	35 MPa	32	93	75	163	75	14	112	98	300	112	38	46	88	60	17	32	5,87	GB2MCE53021A000
GBC SAE24	35 MPa	40	107	85	182	85	14	126	113	300	126	45	56	102	75	17	40	8,257	GB2MCE63021A000
GBC SAE32	35 MPa	50	114	98	195	98	14	133	123	300	133	56	64	118	85	17	50	10,38	GB2MCE73021A000

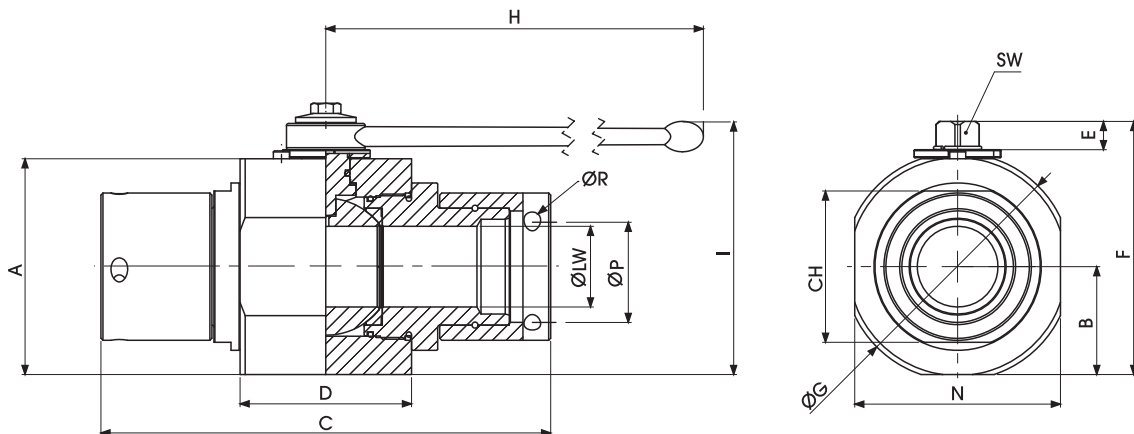

GBC FEMALE SAEJ1467

Standard

CARBON STEEL

TYPE	PN	DN	A	B	C	D	E	F	ØG	H	I	N	CH	ØP	ØR	SW	ØLW	KG	ITEM CODE
GBC SAE20	35 MPa	32	93	75	163	75	14	112	98	300	112	88	60	43	8,5	17	32	5,87	GB2FCE53021A000
GBC SAE24	35 MPa	40	107	85	182	85	14	126	113	300	126	102	75	52	8,5	17	40	8,257	GB2FCE63021A000
GBC SAE32	35 MPa	50	114	98	195	98	14	133	123	300	133	118	85	62	8,5	17	50	10,38	GB2FCE73021A000

+ GBC 2-WAY HIGH PRESSURE BALL VALVES

www.gemels.it

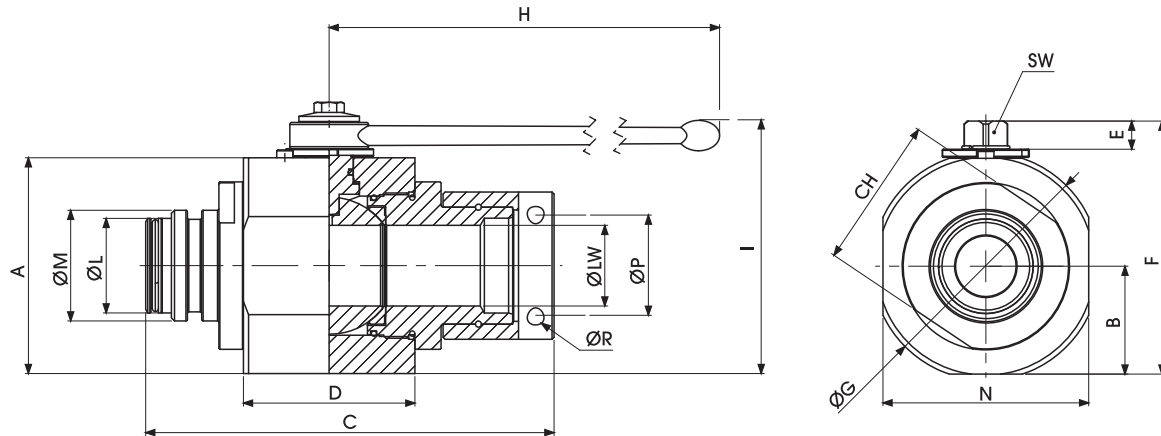

GBC MALE FEMALE SAEJ1467

Standard

CARBON STEEL

TYPE	PN	DN	A	B	C	D	E	F	ØG	H	I	ØL	ØM	N	CH	ØP	ØR	SW	ØLW	KG	ITEM CODE
GBC SAE20	35 MPa	32	93	75	163	75	14	112	98	300	112	38	46	88	60	43	8,5	17	32	5,87	GB2MFE53021A000
GBC SAE24	35 MPa	40	107	85	182	85	14	126	113	300	126	45	56	102	75	52	8,5	17	40	8,257	GB2MFE63021A000
GBC SAE32	35 MPa	50	114	98	195	98	14	133	123	300	133	56	64	118	85	62	8,5	17	50	10,38	GB2MFE73021A000

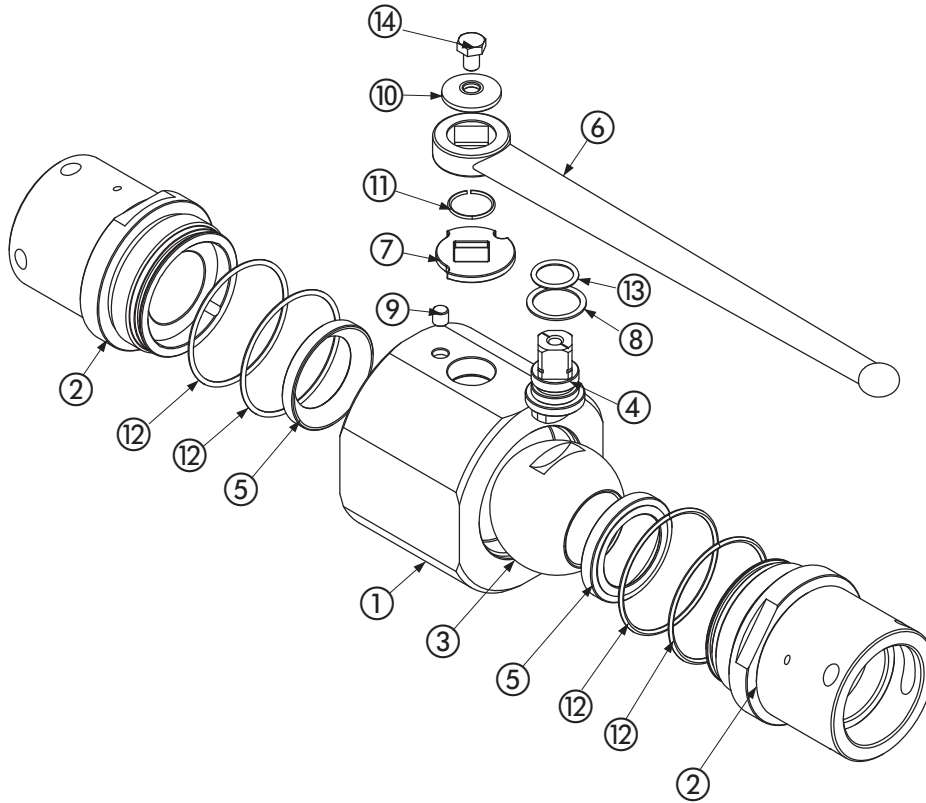

Carbon steel

Pos	Description	Material	Q.tà
1	Body	1,0570	1
2	Adapter	1,0570	2
3	Ball	1,0737	1
4	Stem	1,0737	1
5	Ball seat	POM	2
6	Handle	1,0116	1
7	Washer	1,0116	1
8	Stem ring	POM	1
9	Spine	1,0737	1
10	Washer	1,0737	1
11	Seeger	1,4301	1
12	Adapter o-ring	NBR	4
13	Stem o-ring	NBR	1
14	Screw	ISO4017 8.8	1

On request

- Reduced bore
- O-Ring in FKM, EPDM, HNBR, KALREZ
- Seals in PTFE, PEEK, PA612, GEMPTFE, METAL TO METAL
- Special threads
- Stem in stainless steel 1,4404
- Ball in stainless steel 1,4404
- Pressure class up to PN35 Mpa
- Pneumatic and electrical actuator
- Locking device
- For further special requests please consult our technical/commercial service

GV

GV2 - GV3



TECH
MATERIAL

KITS

LOCKING - HANDLES
FLANGE - LIMIT SWITCHES
ACTUATORS - SEALS KITS

OIL&GAS

GM1-GM - GN
SBF - SBT

OTHER

GHP - GPS - RF
BD - VU - VUJBA

GR

GRC - GRS

GPK

GPK2 - GPK3

G3K-4K

G3K - G4K

GV

GV2 - GV3

GB

GB2 - GB3 - GBF
GBS - GBC

GE

GE1 - GE2 - GE3
GE5 - GE3K - GEF
GES - GEC - GEV

+ GV2

2-WAY HIGH PRESSURE BALL VALVES



GV2



GV5



GV2

CARBON STEEL

- Type: ball valve GV 2 way
- Body: square
- Material: 1,0737/ 1,0737
- Ball seats: from DN6 up to DN32
- O-Rings: NBR, FKM, EPDM, MVQ
- Operating pressure: PN500 - S6000 depending on valve size and seal materials selected
- Temp range: -20°C to +100°C depending on seal material selected

GV2	G 1/2			DN13	1	1	1	1	D	E	
Type and way of valve	GAS DIN/ISO 228 BSP	NPT ANSI/ASME B1.20.1	SAE J1926-1	ISO 6162	Nominal dimension	Body material	Adapter material	Stem material	Ball material	Ball seat material	Adapter and stem seal material
GV2 2-way	G 1/4	N 1/4	SAE4	S6000	DN6	1 1,0737	1 1,0737	1 1,0737	1 1,0737	A POM D PEEK K GEMPTFE C PTFE	B NBR E FKM F EPDM L MVQ
	G 3/8	N 3/8	SAE6		DN10						
	G 1/2	N 1/2	SAE8		DN13						
	G 3/4	N 3/4	SAE12		DN20						
	G 1	N 1	SAE16		DN25						
	G 1 1/4 R	N 1 1/4 R	SAE20R								
	G 1 1/4	N 1 1/4	SAE20								

"The company reserves the right to operate dimensional changes without prior notice".

+ GV2

2-WAY HIGH PRESSURE BALL VALVES

Specialist in Ball Valves

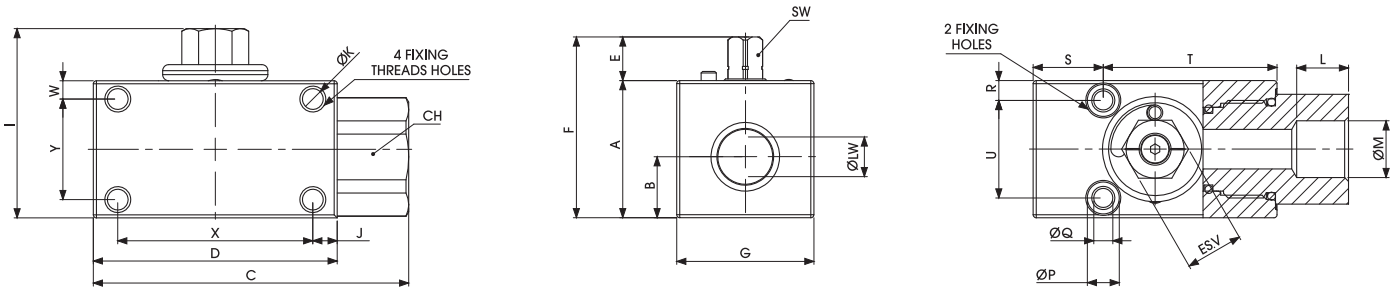

GV2 DIN/ISO 228 BSP

Standard

CARBON STEEL

TYPE	PN	DN	A	B	C	D	E	F	G	I	J	ØK	Y	X	W	L	ØM	CH	ØP	ØQ	R	S	T	U	es.v	ØLW	SW	KG	ITEM CODE
GV2 G 1/4	50 MPa	6	40	17,4	85,5	67	14,5	54,5	37	57,5	5,5	M6	33	56	3,5	15,5	G 1/4	27	10,5	6,25	6,5	14,5	52,5	24	19	6	9	0,932	GV2GGT15011B000
GV2 G 3/8	50 MPa	10	40	19,5	88,5	70	14,5	54,5	37	57,5	7	M6	33	56	3,5	17	G 3/8	32	10,5	6,25	6,5	16	54	24	19	10	9	0,919	GV2GGT25011B000
GV2 G 1/2	50 MPa	13	45	20	103,5	80	14,5	69,5	45	62,5	8	M8	33	64	6	17	G 1/2	36	10,5	6,25	6,5	23	57	32	19	13	9	1,307	GV2GGT35011B000
GV2 G 3/4	50 MPa	20	55	23,4	129,5	101	18,5	73,5	55	77,5	10,5	M8	43	80	6	21	G 3/4	45	13,5	8,25	7,5	25,5	75,5	40	24	20	14	2,424	GV2GGT45011B000
GV2 G 1	50 MPa	25	65	29,5	133,5	105	18,5	83,5	65	87,5	7,5	M8	53	90	6	24	G 1	55	13,5	8,25	8,5	27,5	77,5	48	24	25	14	3,446	GV2GGT55011B000
GV2 G 1 1/4R	50 MPa	25	65	29,5	133,5	105	18,5	83,5	65	87,5	7,5	M8	53	90	6	24	G 1 1/4R	55	13,5	8,25	8,5	27,5	77,5	48	24	25	14	3,265	GV2GGR65011B000
GV2 G 1 1/4	50 MPa	32	80	33,5	133,5	105	18,5	98,5	80	103,5	9,5	M8	64	86	8	24	G 1 1/4	60	13,5	8,25	10	24,5	80,5	60	32	32	17	4,991	GV2GGT65011B000

GV2 ANSI/ASME B1.20.1 NPT

Standard

CARBON STEEL

TYPE	PN	DN	A	B	C	D	E	F	G	I	J	ØK	Y	X	W	L	ØM	CH	ØP	ØQ	R	S	T	U	es.v	ØLW	SW	KG	ITEM CODE
GV2 N 1/4	50 MPa	6	40	17,4	85,5	67	14,5	54,5	37	57,5	5,5	M6	33	56	3,5	15,5	N 1/4	27	10,5	6,25	6,5	14,5	52,5	24	19	6	9	0,932	GV2NNT15011B000
GV2 N 3/8	50 MPa	10	40	19,5	88,5	70	14,5	54,5	37	57,5	7	M6	33	56	3,5	17	N 3/8	32	10,5	6,25	6,5	16	54	24	19	10	9	0,919	GV2NNT25011B000
GV2 N 1/2	50 MPa	13	45	20	103,5	80	14,5	69,5	45	62,5	8	M8	33	64	6	17	N 1/2	36	10,5	6,25	6,5	23	57	32	19	13	9	1,307	GV2NNT35011B000
GV2 N 3/4	50 MPa	20	55	23,4	129,5	101	18,5	73,5	55	77,5	10,5	M8	43	80	6	21	N 3/4	45	13,5	8,25	7,5	25,5	75,5	40	24	20	14	2,424	GV2NNT45011B000
GV2 N 1	50 MPa	25	65	29,5	133,5	105	18,5	83,5	65	87,5	7,5	M8	53	90	6	24	N 1	55	13,5	8,25	8,5	27,5	77,5	48	24	25	14	3,446	GV2NNT55011B000
GV2 N 1 1/4R	50 MPa	25	65	29,5	133,5	105	18,5	83,5	65	87,5	7,5	M8	53	90	6	24	N 1 1/4R	55	13,5	8,25	8,5	27,5	77,5	48	24	25	14	3,265	GV2NNR65011B000
GV2 N 1 1/4	50 MPa	32	80	33,5	133,5	105	18,5	98,5	80	103,5	9,5	M8	64	86	8	24	G 1 1/4	60	13,5	8,25	10	24,5	80,5	60	32	32	17	4,991	GV2NNT65011B000

GV2 SAE J1926-1

Standard

CARBON STEEL

TYPE	PN	DN	A	B	C	D	E	F	G	I	J	ØK	Y	X	W	L	ØM	CH	ØP	ØQ	R	S	T	U	es.v	ØLW	SW	KG	ITEM CODE
GV2 SAE4	50 MPa	6	40	17,4	85,5	67	14,5	54,5	37	57,5	5,5	M6	33	56	3,5	15,5	SAE4	27	10,5	6,25	6,5	14,5	52,5	24	19	6	9	0,932	GV2EEE05011B000
GV2 SAE6	50 MPa	10	40	19,5	88,5	70	14,5	54,5	37	57,5	7	M6	33	56	3,5	17	SAE6	32	10,5	6,25	6,5	16	54	24	19	10	9	0,919	GV2EEE15011B000
GV2 SAE8	50 MPa	13	45	20	103,5	80	14,5	69,5	45	62,5	8	M8	33	64	6	17	SAE8	36	10,5	6,25	6,5	23	57	32	19	13	9	1,307	GV2EEE25011B000
GV2 SAE12	50 MPa	20	55	23,4	129,5	101	18,5	73,5	55	77,5	10,5	M8	43	80	6	21	SAE12	45	13,5	8,25	7,5	25,5	75,5	40	24	20	14	2,424	GV2EEE35011B000
GV2 SAE16	50 MPa	25	65	29,5	133,5	105	18,5	83,5	65	87,5	7,5	M8	53	90	6	24	SAE16	55	13,5	8,25	8,5	27,5	77,5	48	24	25	14	3,446	GV2EEE45011B000
GV2 SAE20R	50 MPa	25	65	29,5	133,5	105	18,5	83,5	65	87,5	7,5	M8	53	90	6	24	SAE20R	55	13,5	8,25	8,5	27,5	77,5	48	24	25	14	3,265	GV2EEE85011B000
GV2 SAE20	50 MPa	32	80	33,5	133,5	105	18,5	98,5	80	103,5	9,5	M8	64	86	8	24	SAE20	60	13,5	8,25	10	24,5	80,5	60	32	32	17	4,991	GV2EEE55011B000

"The company reserves the right to operate dimensional changes without prior notice".

+ GV2

2-WAY HIGH PRESSURE BALL VALVES

www.gemels.it

GV2

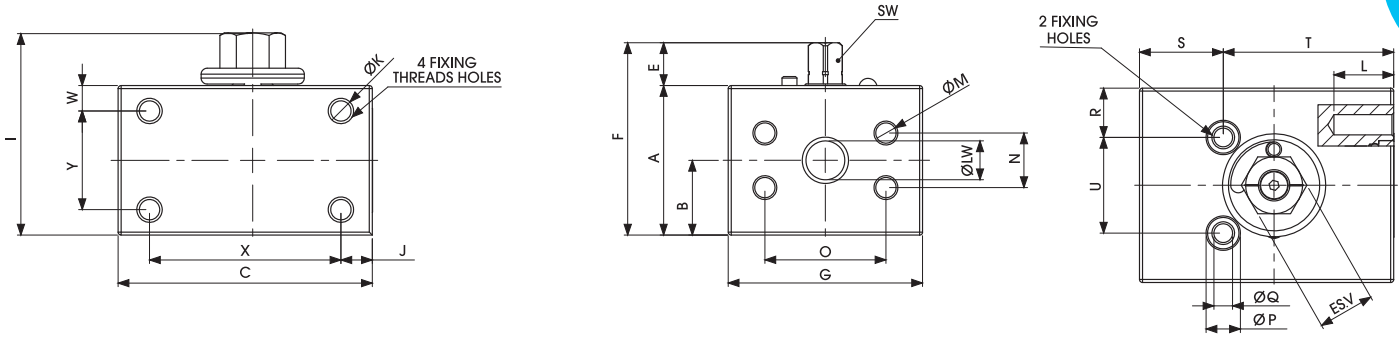

GV2 SAE 6000 ISO6162 COD62

Standard

CARBON STEEL

TYPE	PN	DN	A	B	C	E	F	G	I	J	ØK	Y	X	W	L	ØM	N	O	ØP	ØQ	R	S	T	U	ES.V	ØLW	SW	KG	ITEM CODE
GV2 S6000	42 MPa	13	50	25	85	14,5	64,5	65	67,5	10,5	M10	33	64	12,5	18	M8	18,24	40,49	15	9	16,5	28	56	38	19	13	9	2,159	GV2FFT3G011B000
GV2 S6000	42 MPa	20	65	33,4	105	18,5	83,5	80	87,5	12,5	M10	43	80	10,1	18	M10	23,8	50,8	17	11	20	29,5	73,5	52	24	20	14	3,932	GV2FFT4G011B000
GV2 S6000	42 MPa	25	75	39,5	110	18,5	93,5	90	97,5	10	M10	53	90	9	20	M12	27,76	57,15	17	11	21	32,5	75,5	55	24	25	14	5,239	GV2FFT5G011B000
GV2 S6000	42 MPa	32	85	38,5	115	18,5	103,5	100	108,5	14,5	M10	64	86	14,5	22	M12	31,75	66,68	20	13	20	34,5	79,5	67	32	32	17	6,75	GV2FFT6G011B000

Carbon steel

Pos	Description	Material	Q.tà
1	Body	1,0737	1
2	Adapter	1,0737	1
3	Ball	1,0737	1
4	Spring UNI17223-1	1,0116	1
5	Stem	1,0737	1
6	Ball seat	POM	2
7	Washer	1,0737	1
8	Stem ring	POM	1
9	Spine	1,0737	1
10	Spring ball	1,0116	1
11	Adapter o-ring	FKM	2
12	Adapter o-ring	FKM	2
13	Stem o-ring	FKM	1
14	Screw	DIN 7991 8.8	1
15	Caps	PVC	2

On request

- Reduced bore
- O-Ring in FKM, EPDM, HNBR, KALREZ
- Seals in PTFE, PEEK, PA612, GEMPTFE, METAL TO METAL
- Special threads
- Pressure class up to PN50 Mpa
- Locking device

• For further special requests please consult our technical/commercial service

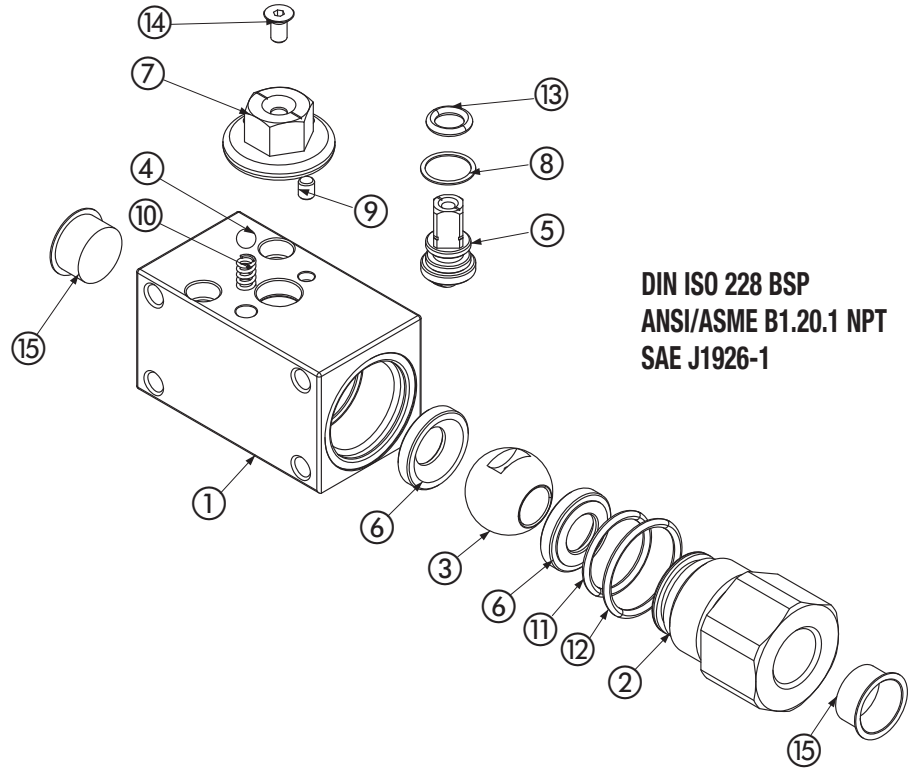

DIN ISO 228 BSP
ANSI/ASME B1.20.1 NPT
SAE J1926-1

Carbon steel

Pos	Description	Material	Q.tà
1	Body	1,0737	1
2	Adapter	1,0737	1
3	Ball	1,0737	1
4	Spring ball	1,0116	1
5	Stem	1,0737	1
6	Ball seat	POM	2
7	Washer	1,0737	1
8	Stem ring	POM	1
9	Spine	1,0737	1
10	Spring UNI17223-1	1,0116	1
11	Adapter o-ring	FKM	2
12	Adapter o-ring	FKM	2
13	Stem o-ring	FKM	1
14	Screw	DIN 7991 8.8	1

On request

- Reduced bore
- O-Ring in FKM, EPDM, HNBR, KALREZ
- Seals in PTFE, PEEK, PA612, GEMPTFE, METAL TO METAL
- Special threads
- Pressure class up to PN6000 Psi
- Locking device

• For further special requests please consult our technical/commercial service

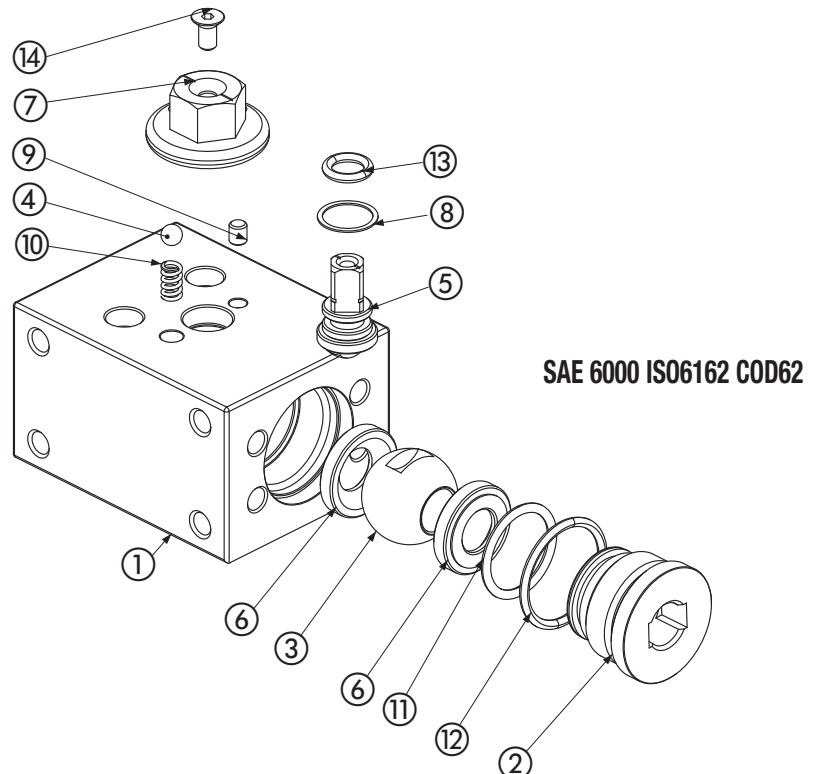

SAE 6000 ISO6162 COD62

+ GV3

3-WAY HIGH PRESSURE BALL VALVES

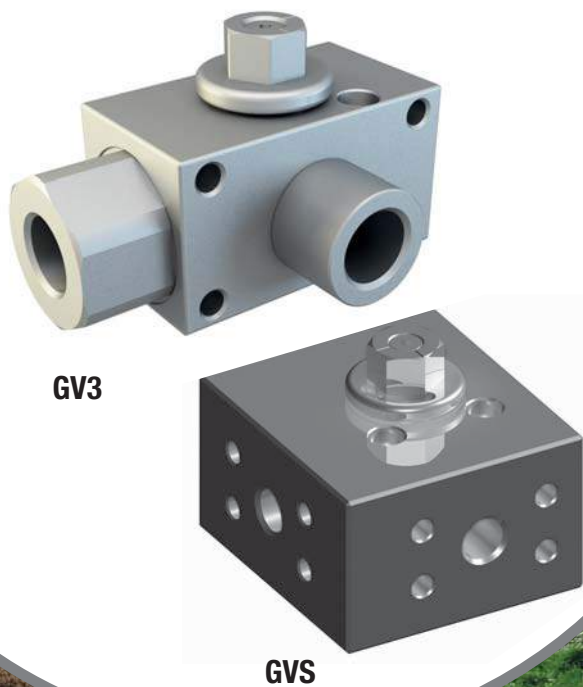

GV3



CARBON STEEL

- Type: ball valve GV 3 way
- Body: square
- Material: 1,0737/ 1,0737
- Ball seats: from DN6 up to DN32
- O-Rings: NBR, FKM, EPDM, MVQ
- Operating pressure: PN 500 - S6000 depending on valve size and seal materials selected
- Temp range: -20°C to +100°C depending on seal material selected

GV3	G 1/2		DN13	1	1	1	1	D	E		
Type and way of valve	GAS DIN/ISO 228 BSP	NPT ANSI/ASME B1.20.1	SAE J1926-1	ISO 6162	Nominal dimension	Body material	Adapter material	Stem material	Ball material	Ball seat material	Adapter and stem seal material
GV3 3-way	G 1/4	N 1/4	SAE4	S6000	DN6	1 1,0737	1 1,0737	1 1,0737	1 1,0737	A POM D PEEK K GEMPTFE C PTFE	B NBR E FKM F EPDM L MVQ
	G 3/8	N 3/8	SAE6		DN10						
	G 1/2	N 1/2	SAE8		DN13						
	G 3/4	N 3/4	SAE12		DN20						
	G 1	N 1	SAE16		DN25						
	G 1 1/4 R	N 1 1/4 R	SAE20R								
	G 1 1/4	N 1 1/4	SAE20								

+ GV3

3-WAY HIGH PRESSURE BALL VALVES

Specialist in Ball Valves

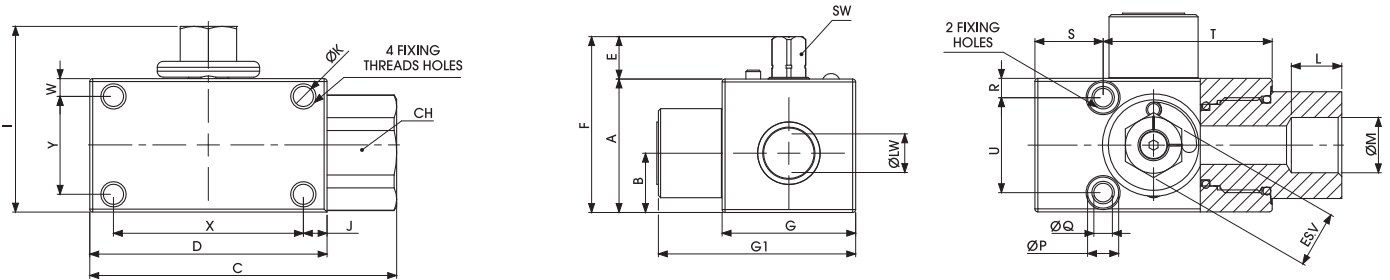

GV3 DIN/ISO 228 BSP

Standard

CARBON STEEL

TYPE	PN	DN	A	B	C	D	E	F	G	G1	I	J	ØK	Y	X	W	L	ØM	CH	ØP	ØQ	R	S	T	U	ES.V	ØLW	SW	KG	ITEM CODE
GV3 G 1/4	50 MPa	6	40	17,4	85,5	67	14,5	54,5	37	60,5	57,5	5,5	M6	33	56	3,5	15,5	G 1/4	27	10,5	6,25	6,5	14,5	52,5	24	19	6	9	1,08	GV3GGT14011B000
GV3 G 3/8	50 MPa	10	40	19,5	88,5	70	14,5	54,5	37	61	57,5	7	M6	33	56	3,5	17	G 3/8	32	10,5	6,25	6,5	16	54	24	19	10	9	1,15	GV3GGT24011B000
GV3 G 1/2	50 MPa	13	45	20	103,5	80	14,5	69,5	45	66,5	62,5	8	M8	33	64	6	17	G 1/2	36	10,5	6,25	6,5	23	57	32	19	13	9	1,362	GV3GGT33011B000
GV3 G 3/4	35 MPa	20	55	23,4	129,5	101	18,5	73,5	55	85	77,5	10,5	M8	43	80	6	21	G 3/4	45	13,5	8,25	7,5	25,5	75,5	40	24	20	14	2,51	GV3GGT43011B000
GV3 G 1	35 MPa	25	65	29,5	133,5	105	18,5	83,5	65	97,5	87,5	7,5	M8	53	90	6	24	G 1	55	13,5	8,25	8,5	27,5	77,5	48	24	25	14	3,564	GV3GGT53011B000
GV3 G 1 1/4R	35 MPa	25	65	29,5	133,5	105	18,5	83,5	65	99	87,5	7,5	M8	53	90	6	24	G 1 1/4R	55	13,5	8,25	8,5	27,5	77,5	48	24	25	14	3,485	GV3GGR63011B000
GV3 G 1 1/4	35 MPa	32	80	33,5	133,5	105	18,5	98,5	80	118	103,5	9,5	M8	64	86	8	24	G 1 1/4	60	13,5	8,25	10	24,5	80,5	60	32	32	17	5,32	GV3GGT63011B000

GV3 ANSI/ASME B1.20.1 NPT

Standard

CARBON STEEL

TYPE	PN	DN	A	B	C	D	E	F	G	G1	I	J	ØK	Y	X	W	L	ØM	CH	ØP	ØQ	R	S	T	U	ES.V	ØLW	SW	KG	ITEM CODE
GV3 N 1/4	50 MPa	6	40	17,4	85,5	67	14,5	54,5	37	60,5	57,5	5,5	M6	33	56	3,5	15,5	N 1/4	27	10,5	6,25	6,5	14,5	52,5	24	19	6	9	1,08	GV3NNT14011B000
GV3 N 3/8	50 MPa	10	40	19,5	88,5	70	14,5	54,5	37	61	57,5	7	M6	33	56	3,5	17	N 3/8	32	10,5	6,25	6,5	16	54	24	19	10	9	1,15	GV3NNT24011B000
GV3 N 1/2	50 MPa	13	45	20	103,5	80	14,5	69,5	45	66,5	62,5	8	M8	33	64	6	17	N 1/2	36	10,5	6,25	6,5	23	57	32	19	13	9	1,362	GV3NNT33011B000
GV3 N 3/4	35 MPa	20	55	23,4	129,5	101	18,5	73,5	55	85	77,5	10,5	M8	43	80	6	21	N 3/4	45	13,5	8,25	7,5	25,5	75,5	40	24	20	14	2,51	GV3NNT43011B000
GV3 N 1	35 MPa	25	65	29,5	133,5	105	18,5	83,5	65	97,5	87,5	7,5	M8	53	90	6	24	N 1	55	13,5	8,25	8,5	27,5	77,5	48	24	25	14	3,564	GV3NNT53011B000
GV3 N 1 1/4R	35 MPa	25	65	29,5	133,5	105	18,5	83,5	65	99	87,5	7,5	M8	53	90	6	24	N 1 1/4R	55	13,5	8,25	8,5	27,5	77,5	48	24	25	14	3,485	GV3NNR63011B000
GV3 N 1 1/4	35 MPa	32	80	33,5	133,5	105	18,5	98,5	80	118	103,5	9,5	M8	64	86	8	24	G 1 1/4	60	13,5	8,25	10	24,5	80,5	60	32	32	17	5,32	GV3NNT63011B000

GV3 SAE J1926-1

Standard

CARBON STEEL

TYPE	PN	DN	A	B	C	D	E	F	G	G1	I	J	ØK	Y	X	W	L	ØM	CH	ØP	ØQ	R	S	T	U	ES.V	ØLW	SW	KG	ITEM CODE
GV3 SAE4	50 MPa	6	40	17,4	85,5	67	14,5	54,5	37	60,5	57,5	5,5	M6	33	56	3,5	15,5	SAE4	27	10,5	6,25	6,5	14,5	52,5	24	19	6	9	1,08	GV3EEE04011B000
GV3 SAE6	50 MPa	10	40	19,5	88,5	70	14,5	54,5	37	61	57,5	7	M6	33	56	3,5	17	SAE6	32	10,5	6,25	6,5	16	54	24	19	10	9	1,15	GV3EEE14011B000
GV3 SAE8	50 MPa	13	45	20	103,5	80	14,5	69,5	45	66,5	62,5	8	M8	33	64	6	17	SAE8	36	10,5	6,25	6,5	23	57	32	19	13	9	1,362	GV3EEE23011B000
GV3 SAE12	35 MPa	20	55	23,4	129,5	101	18,5	73,5	55	85	77,5	10,5	M8	43	80	6	21	SAE12	45	13,5	8,25	7,5	25,5	75,5	40	24	20	14	2,51	GV3EEE33011B000
GV3 SAE16	35 MPa	25	65	29,5	133,5	105	18,5	83,5	65	97,5	87,5	7,5	M8	53	90	6	24	SAE16	55	13,5	8,25	8,5	27,5	77,5	48	24	25	14	3,564	GV3EEE43011B000
GV3 SAE20R	35 MPa	25	65	29,5	133,5	105	18,5	83,5	65	99	87,5	7,5	M8	53	90	6	24	SAE20R	55	13,5	8,25	8,5	27,5	77,5	48	24	25	14	3,485	GV3EEE83011B000
GV3 SAE20	35 MPa	32	80	33,5	133,5	105	18,5	98,5	80	118	103,5	9,5	M8	64	86	8	24	SAE20	60	13,5	8,25	10	24,5	80,5	60	32	32	17	5,32	GV3EEE53011B000

"The company reserves the right to operate dimensional changes without prior notice".

+ GVS6 3V 3-WAY HIGH PRESSURE BALL VALVES

www.gemels.it

GV3

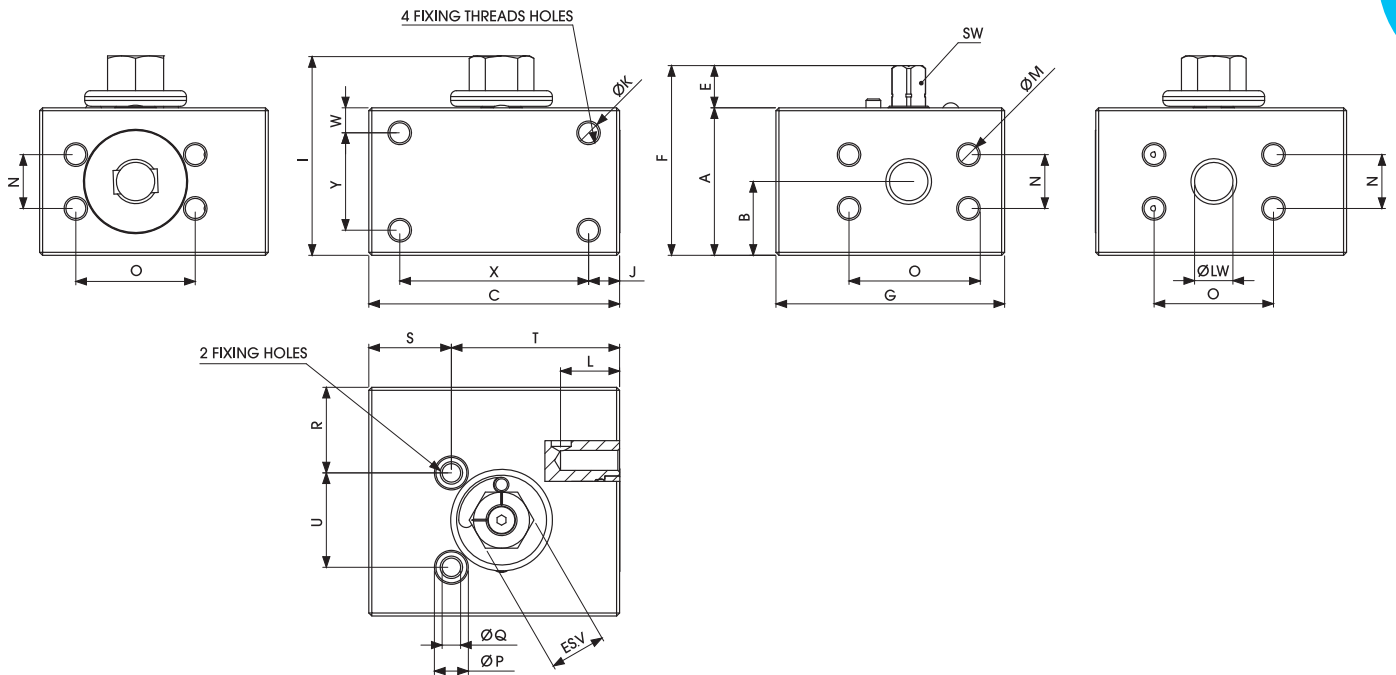

GVS6 3V SAE 6000 ISO6162 COD62

Standard

CARBON STEEL

TYPE	PN	DN	A	B	C	E	F	G	I	J	ØK	Y	X	W	L	ØM	N	O	ØP	ØQ	R	S	T	U	ES.V	ØLW	SW	KG	ITEM CODE
GVS6 3V S6000	50 MPa	13	50	25	85	14,5	64,5	77,5	67,5	10,5	M10	33	64	12,5	18	M8	18,24	40,49	15	9	16,5	28	56	38	19	13	9	2,373	GV3FFT3G011B000
GVS6 3V S6000	42 MPa	20	65	33,4	105	18,5	83,5	90	87,5	12,5	M10	43	80	10,1	18	M10	23,8	50,8	17	11	20	29,5	73,5	52	24	20	14	4,355	GV3FFT4G011B000
GVS6 3V S6000	42 MPa	25	75	39,5	110	18,5	93,5	105	97,5	10	M10	53	90	9	20	M12	27,76	57,15	17	11	21	32,5	75,5	55	24	25	14	5,997	GV3FFT5G011B000
GVS6 3V S6000	42 MPa	32	85	38,5	115	18,5	103,5	117,5	108,5	14,5	M10	64	86	14,5	22	M12	31,75	66,68	20	13	20	34,5	79,5	67	32	32	17	7,745	GV3FFT6G011B000

+ GV3

3-WAY HIGH PRESSURE BALL VALVES

Specialist in Ball Valves

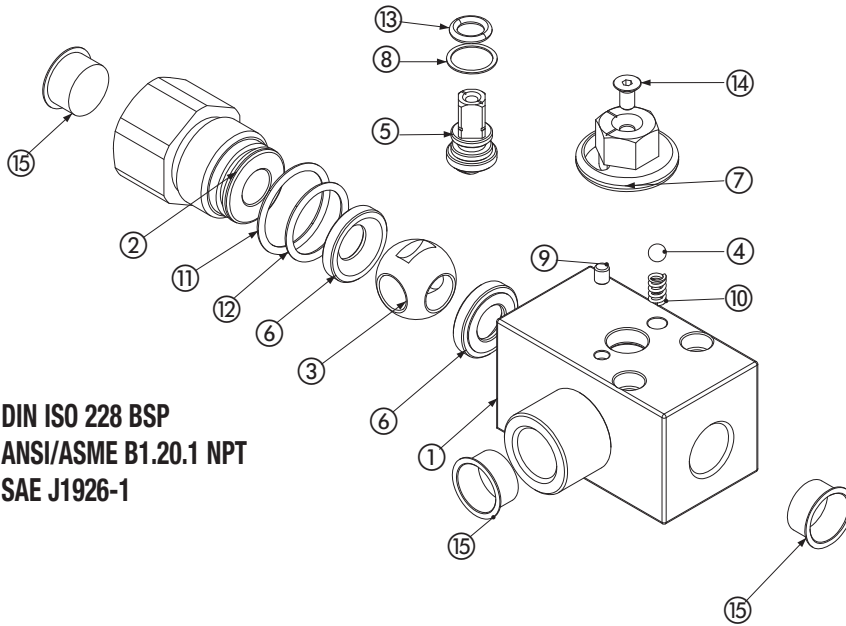

DIN ISO 228 BSP
ANSI/ASME B1.20.1 NPT
SAE J1926-1

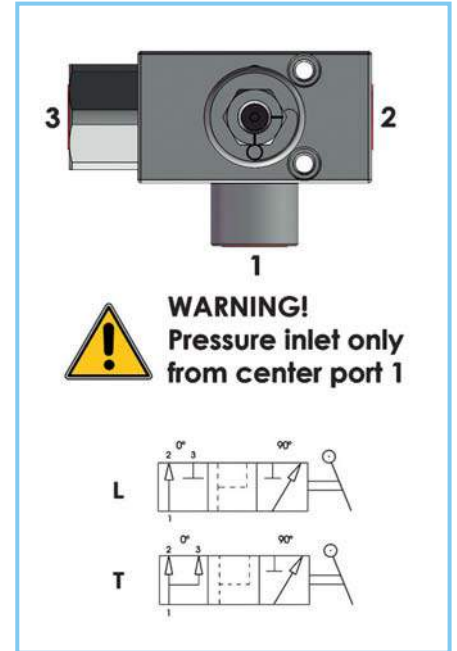

Carbon steel			
Pos	Description	Material	Q.tà
1	Body	1,0737	1
2	Adapter	1,0737	1
3	Ball	1,0737	1
4	Spring	1,0116	1
5	Stem	1,0737	1
6	Ball seat	POM	2
7	Washer	1,0737	1
8	Stem ring	POM	1
9	Spine	1,0737	1
10	Spring ball	1,0116	1
11	Adapter o-ring	FKM	2
12	Adapter o-ring	FKM	2
13	Stem o-ring	FKM	1
14	Screw	DIN 7991 8.8	1
15	Caps	PVC	3

- On request**
- Reduced bore
 - O-Ring in FKM, EPDM, HNBR, KALREZ
 - Seals in PTFE, PEEK, PA612, GEMPTFE, METAL TO METAL
 - Special threads
 - Pressure class up to PN40 Mpa
 - Locking device

• For further special requests please consult our technical/commercial service

+ GVS6 3V 3-WAY HIGH PRESSURE BALL VALVES

www.gemels.it

2016 - Edition 1

GV3

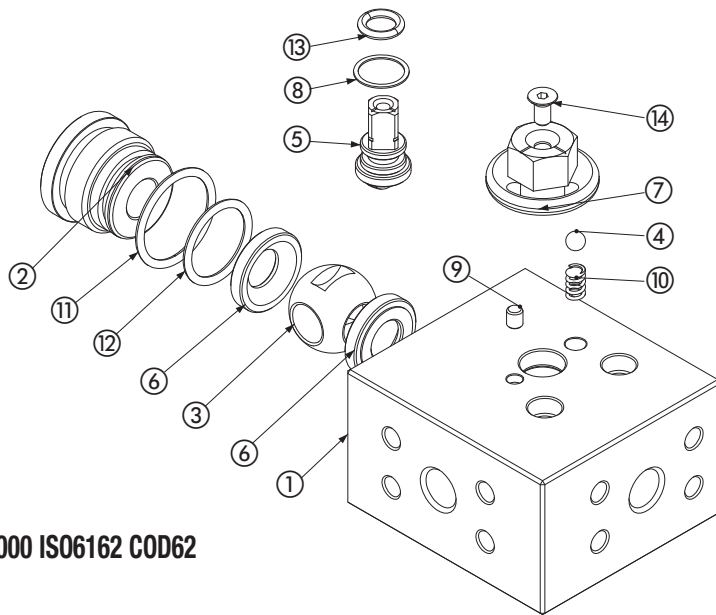

SAE 6000 ISO6162 COD62

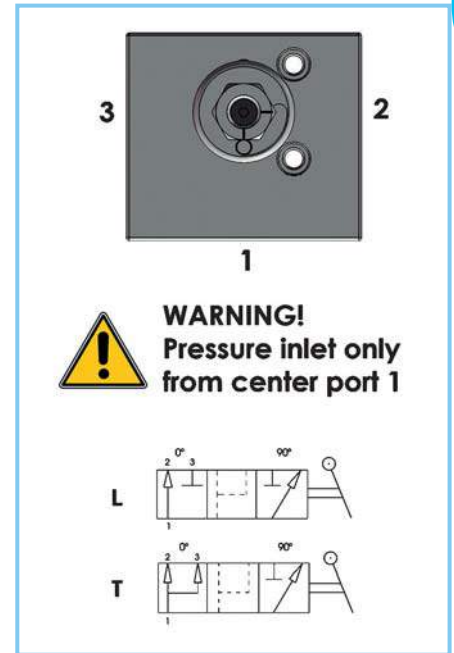

Carbon steel			
Pos	Description	Material	Q.tà
1	Body	1,0737	1
2	Adapter	1,0737	1
3	Ball	1,0737	1
4	Spring ball	1,0116	1
5	Stem	1,0737	1
6	Ball seat	POM	2
7	Washer	1,0737	1
8	Stem ring	POM	1
9	Spine	1,0737	1
10	Spring	1,0116	1
11	Adapter o-ring	FKM	2
12	Adapter o-ring	FKM	2
13	Stem o-ring	FKM	1
14	Screw	DIN 7991 8.8	1

- On request**
- Reduced bore
 - O-Ring in FKM, EPDM, HNBR, KALREZ
 - Seals in PTFE, PEEK, PA612, GEMPTFE, METAL TO METAL
 - Special threads
 - Pressure class up to PN6000 Psi
 - Locking device
 - For further special requests please consult our technical/commercial service

G3K-G4K

G3K - G4K



TECH
MATERIAL

LOCKING - HANDLES
FLANGE - LIMIT SWITCHES
ACTUATORS - SEALS KITS

KITS

OIL&GAS

GMI-GM - GN
SBF - SBT

OTHER

GHP - GPS - RF
BD - VU - VUBA

GR

GRC - GRS

GPK

GPK2 - GPK3

G3K-4K

G3K - G4K

GV

GV2 - GV3

GB

GB2 - GB3 - GBF
GBS - GBC

GE

GEM - GE1 - GE2 - GE3
GE5 - GE3K - GEF
GES - GEC - GEV

+ G3K

3-WAY HIGH PRESSURE BALL VALVES

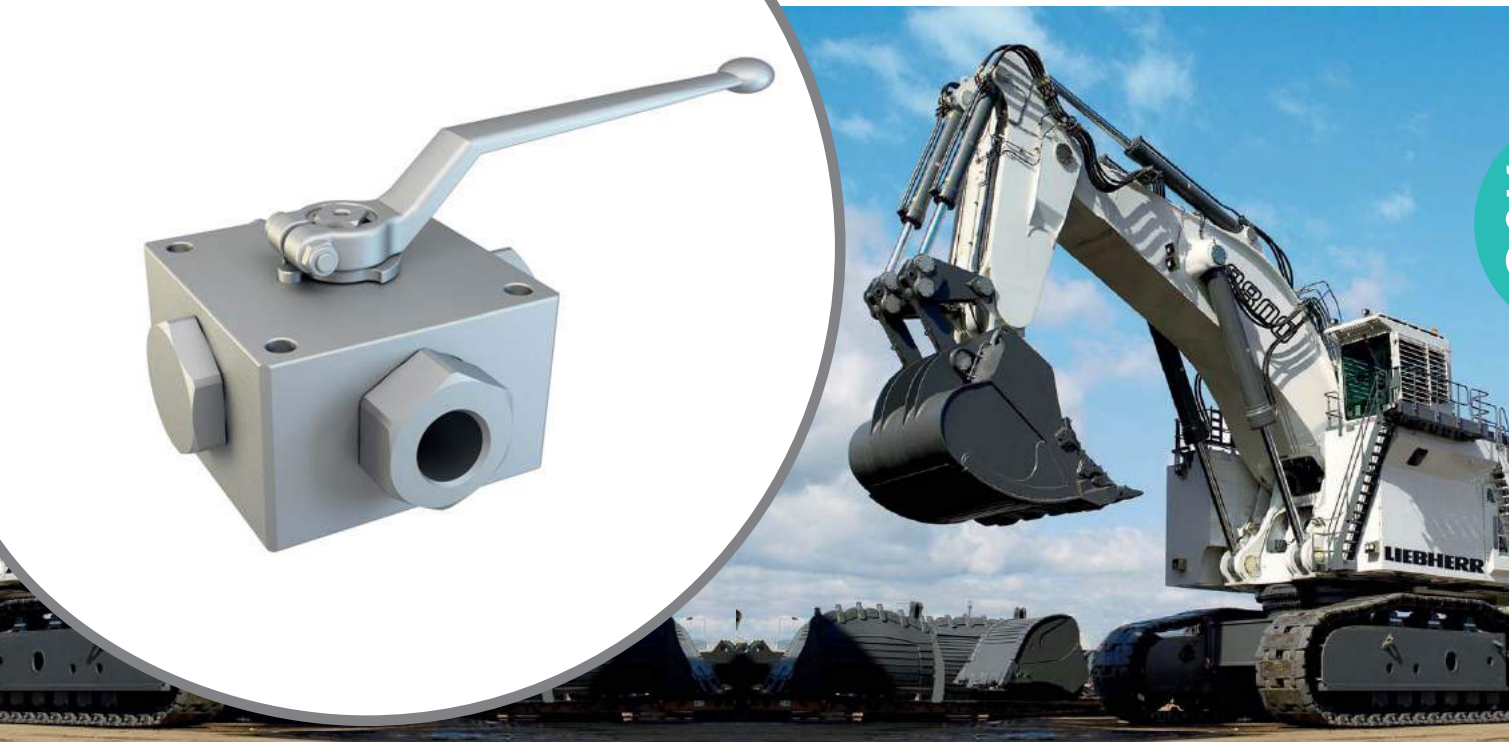
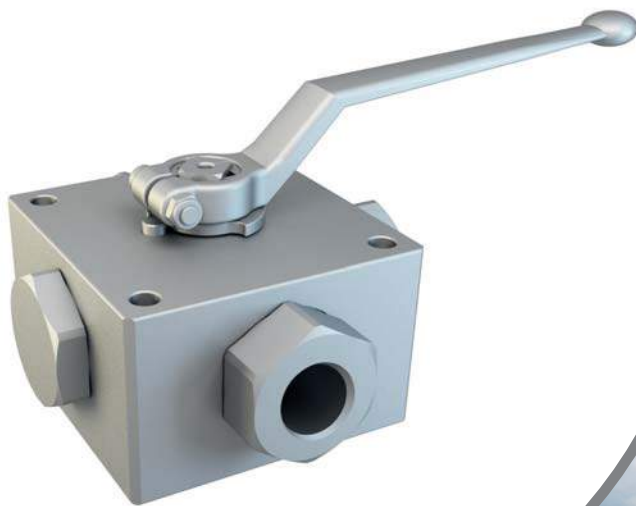

G3K

CARBON STEEL

- Type: ball valve G3K 3 way
- Body: square
- Material: 1,0737/1,0737
- Ball seats: from DN6 up to DN25
- O-Rings: NBR
- Operating pressure: 500 Bar depending on valve size and seal materials selected
- Temp range: -20°C to +100°C depending on seal material selected

G3K	K01	G 1/4	DN6	1	1	1	1	A	B	
Type and way of valve	Type of way	GAS DIN/ISO 228 BSP	NPT ANSI/ASME B1.20.1	Nominal dimension	Body material	Adapter material	Stem material	Ball material	Ball seat material	Adapter and stem seal material
G3K 3-way	L K01	G 1/4	N 1/4	DN6	1 1,0737	1 1,0737	1 1,0737	1 1,0737	A POM	B NBR
	T K02	G 3/8	N 3/8	DN10						
	X K14	G 1/2	N 1/2	DN13						
		G 3/4	N 3/4	DN20						
		G 1	N 1	DN25						
		G 1 1/4 R	N 1 1/4 R							
		G 1 1/2 R	N 1 1/2 R							



3-WAY HIGH PRESSURE BALL VALVES

Specialist in Ball Valves

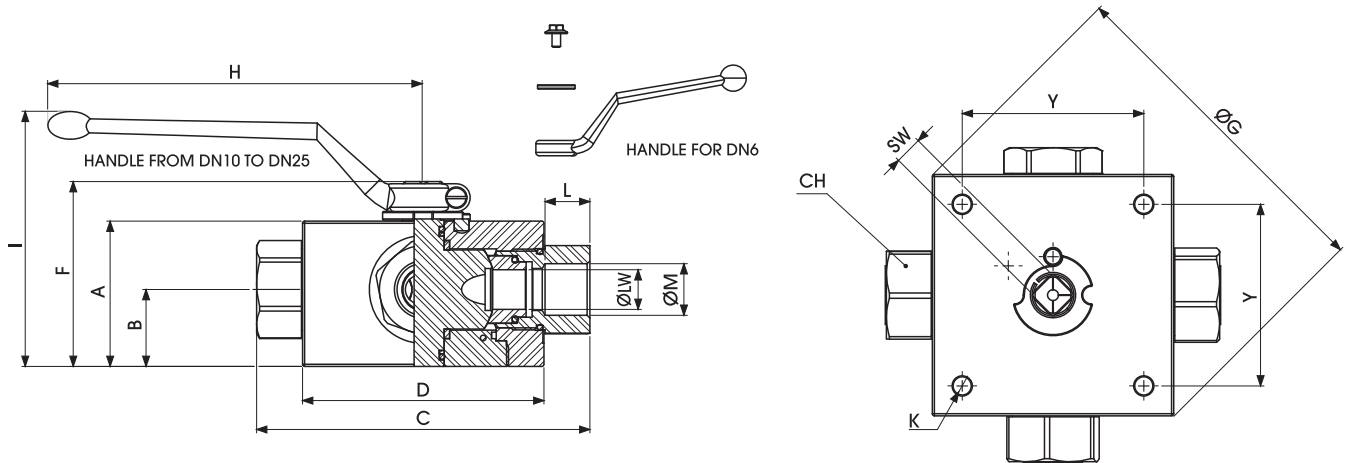

G3K DIN ISO 228 BSP

Standard

TYPE	PN	DN	A	B	C	D	E	F	ØG	H	I	L	ØM	CH	K	Y	SW	LW	KG
G3K G 1/4	50 MPa	6	42	21,5	100	70	11	56,5	-	110	97,5	15,5	G 1/4	24	6,5	55	9	6	1,767
G3K G 3/8	50 MPa	10	53	28,5	115	80	14	71,5	-	180	101	15,5	G 3/8	30	6,5	65	14	10	3,018
G3K G 1/2	40 MPa	13	62	33	136	100	14	80,5	-	180	110	17	G 1/2	41	8,5	80	14	13	5,247
G3K G 3/4	35 MPa	20	68	36	156	113	14	86,5	-	300	116,5	21	G 3/4	41	8,5	85	14	20	6,898
G3K G 1	35 MPa	25	82	47,5	181	118	14	100,5	138	300	130,5	24	G 1	50	8,5	85	14	25	9,005
G3K G 1 1/4 R	35 MPa	25	82	47,5	181	118	14	100,5	138	300	130,5	24	G 1 1/4	55	8,5	85	14	25	8,989
G3K G 1 1/2 R	35 MPa	25	82	47,5	181	118	14	100,5	138	300	130,5	24	G 1 1/2	60	8,5	85	14	25	9,213

G3K ANSI/ASME B1.20.1 NPT

Standard

TYPE	PN	DN	A	B	C	D	E	F	ØG	H	I	L	ØM	CH	K	Y	SW	LW	KG
G3K N 1/4	50 MPa	6	42	21,5	100	70	11	56,5	-	110	97,5	15,5	N 1/4	24	6,5	55	9	6	1,767
G3K N 3/8	50 MPa	10	53	28,5	115	80	14	71,5	-	180	101	15,5	N 3/8	30	6,5	65	14	10	3,018
G3K N 1/2	40 MPa	13	62	33	136	100	14	80,5	-	180	110	17	N 1/2	41	8,5	80	14	13	5,247
G3K N 3/4	35 MPa	20	68	36	156	113	14	86,5	-	300	116,5	21	N 3/4	41	8,5	85	14	20	6,898
G3K N 1	35 MPa	25	82	47,5	181	118	14	100,5	138	300	130,5	24	N 1	50	8,5	85	14	25	9,005
G3K N 1 1/4 R	35 MPa	25	82	47,5	181	118	14	100,5	138	300	130,5	24	N 1 1/4	55	8,5	85	14	25	8,989
G3K N 1 1/2 R	35 MPa	25	82	47,5	181	118	14	100,5	138	300	130,5	24	N 1 1/2	60	8,5	85	14	25	9,213

+ G3K

3-WAY HIGH PRESSURE BALL VALVES

www.gemels.it

Standard schemes

L scheme

G3 K01

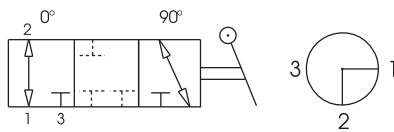

G3K DIN ISO 228 BSP

Standard

CARBON STEEL	
ØLW-K01	ITEM CODE G3K01
6	G23GGT15011A000
10	G23GGT25011A000
13	G23GGT34011A000
19	G23GGT43011A000
23	G23GGT53011A000
23	G23GGR63011A000
23	G23GGR73011A000

G3K ANSI/ASME B1.20.1 NPT

Standard

CARBON STEEL	
ØLW-K01	ITEM CODE G3K01
6	G23NNT15011A000
10	G23NNT25011A000
13	G23NNT34011A000
19	G23NNT43011A000
23	G23NNT53011A000
23	G23NNR63011A000
23	G23NNR73011A000

T scheme

G3 K02

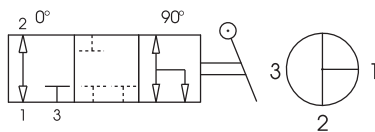

CARBON STEEL	
ØLW-K02	ITEM CODE G3K02
6	G2AGGT15011A000
10	G2AGGT25011A000
13	G2AGGT34011A000
19	G2AGGT43011A000
23	G2AGGT53011A000
23	G2AGGR63011A000
23	G2AGGR73011A000

CARBON STEEL	
ØLW-K02	ITEM CODE G3K02
6	G2ANNT15011A000
10	G2ANNT25011A000
13	G2ANNT34011A000
19	G2ANNT43011A000
23	G2ANNT53011A000
23	G2ANNR63011A000
23	G2ANNR73011A000

X scheme

G3 K14

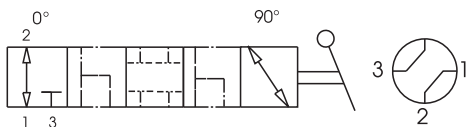

CARBON STEEL	
ØLW-K14	ITEM CODE G3K14
5	G2BGGT15011A000
7	G2BGGT25011A000
10	G2BGGT34011A000
15	G2BGGT43011A000
17	G2BGGT53011A000
17	G2BGR63011A000
17	G2BGR73011A000

CARBON STEEL	
ØLW-K14	ITEM CODE G3K14
5	G2BNNT15011A000
7	G2BNNT25011A000
10	G2BNNT34011A000
15	G2BNNT43011A000
17	G2BNNT53011A000
17	G2BNNR63011A000
17	G2BNNR73011A000

Special schemes on request

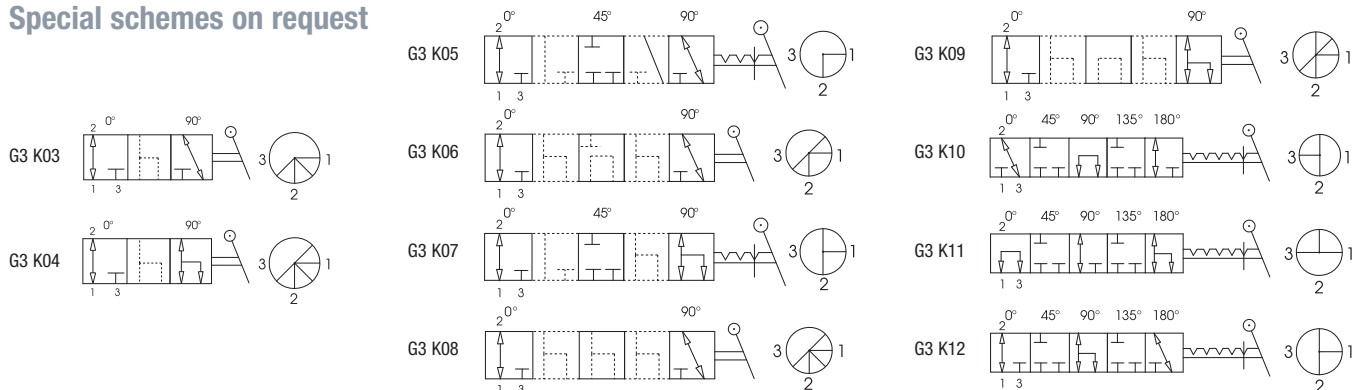

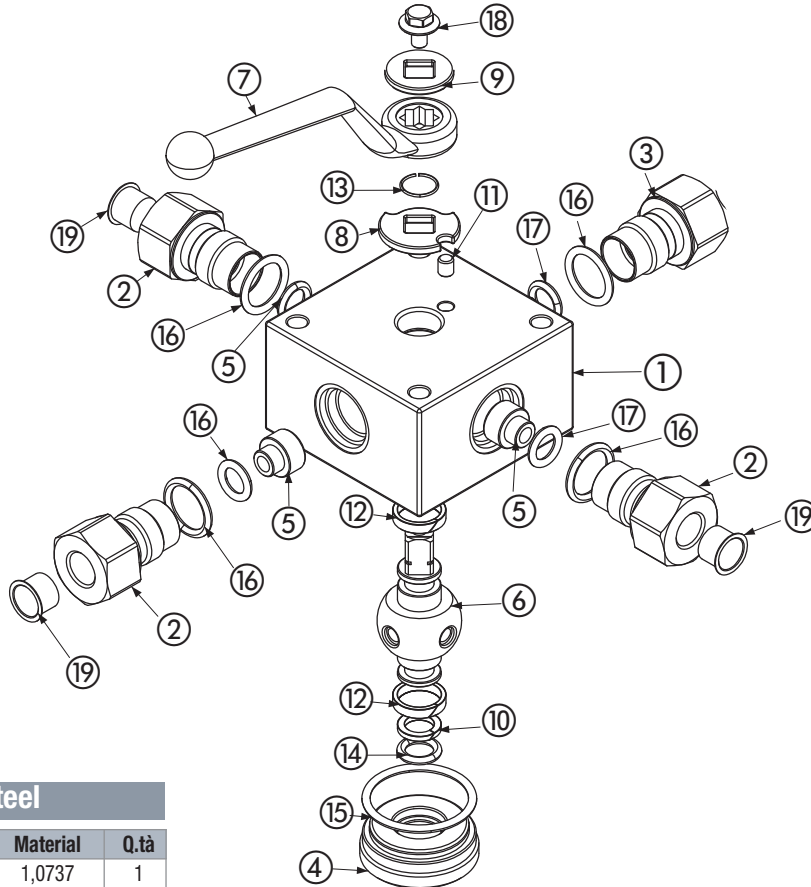

Carbon steel

Pos	Description	Material	Q.tà
1	Body	1,0737	1
2	Adapter	1,0737	4
3	Close adapter	1,0737	1
4	Stemball adapter	1,0737	1
5	Ball Seat	POM	4
6	Ball stem	1,0737	1
7	Handle	ZINC	1
8	Washer	1,0116	1
9	Washer	1,0116	1
10	Stemball ring	PTFE	2
11	Spine	1,0737	1
12	Body ring	PTFE	2
13	Seeger	1,4301	1
14	Stemball o-ring	NBR	2
15	Body o-ring	NBR	1
16	Adapter o-ring	NBR	4
17	Seal o-ring	NBR	4
18	Screw	DIN 6921 8.8	1
19	Caps	PVC	4

For further special requests please consult our technical/commercial service

On request

- Reduced bore
- O-Ring in FKM, EPDM, HNBR, KALREZ
- Seals in PTFE, PEEK, PA612, GEMPTFE, METAL TO METAL
- Special threads
- Stem in stainless steel 1,4404
- Ball in stainless steel 1,4404
- Pressure class up to PN35 MPa
- Pneumatic and electrical actuator
- Locking device

+ G4K

4-WAY HIGH PRESSURE BALL VALVES

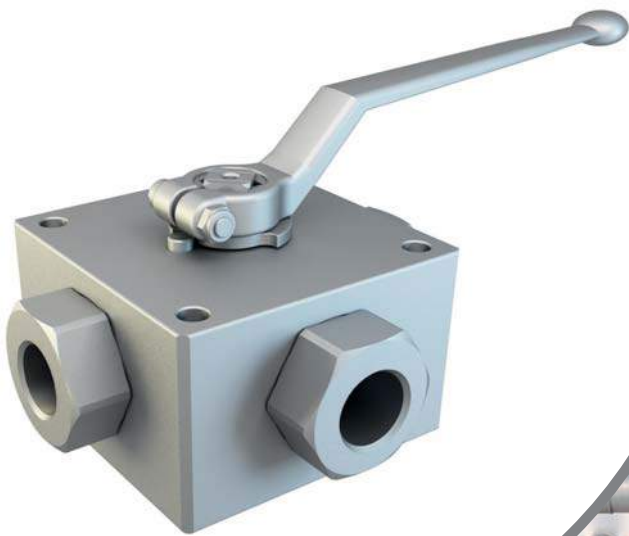

G4K

CARBON STEEL

- Type: ball valve G4K 4 way
- Body: square
- Material: 1,0570/1,0737
- Ball seats: from DN6 up to DN25
- O-Rings: NBR
- Operating pressure: 500 Bar depending on valve size and seal materials selected
- Temp range: -20°C to +100°C depending on seal material selected

G4K	K01	G 1/4		DN6	1	1	1	1	A	B
Type and way of valve	Type of way	GAS DIN/ISO 228 BSP	NPT ANSI/ASME B1.20.1	Nominal dimension	Body material	Adapter material	Stem material	Ball material	Ball seat material	Adapter and stem seal material
G4K 4-way	L K01	G 1/4	N 1/4	DN6	1 1,0737	1 1,0737	1 1,0737	1 1,0737	A POM	B NBR
	T K13	G 3/8	N 3/8	DN10						
	X K14	G 1/2	N 1/2	DN13						
		G 3/4	N 3/4	DN20						
		G 1	N 1	DN25						
		G 1 1/4 R	N 1 1/4 R							
	G 1 1/2 R	N 1 1/2 R								

+ G4K

4-WAY HIGH PRESSURE BALL VALVES

Specialist in Ball Valves

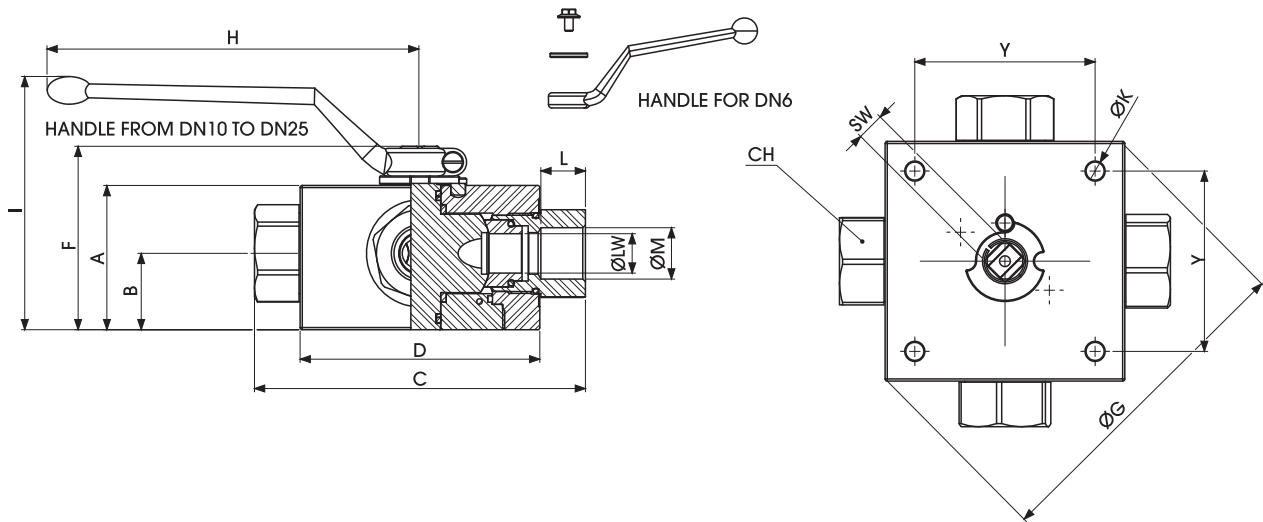

G4K DIN ISO 228 BSP

Standard

TYPE	PN	DN	A	B	C	D	E	F	ØG	H	I	L	ØM	CH	ØK	Y	SW	LW	KG
G4K G 1/4	50 MPa	6	42	21,5	100	70	11	56,5	-	110	97,5	15,5	G 1/4	24	6,5	55	9	6	1,767
G4K G 3/8	50 MPa	10	53	28,5	115	80	14	71,5	-	180	101	15,5	G 3/8	30	6,5	65	14	10	3,018
G4K G 1/2	40 MPa	13	62	33	136	100	14	80,5	-	180	110	17	G 1/2	41	8,5	80	14	13	5,247
G4K G 3/4	35 MPa	20	68	36	156	113	14	86,5	-	300	116,5	21	G 3/4	41	8,5	85	14	20	6,898
G4K G 1	35 MPa	25	82	47,5	181	118	14	100,5	138	300	130,5	24	G 1	50	8,5	85	14	25	9,005
G4K G 1 1/4 R	35 MPa	25	82	47,5	181	118	14	100,5	138	300	130,5	24	G 1 1/4	55	8,5	85	14	25	8,989
G4K G 1 1/2 R	35 MPa	25	82	47,5	181	118	14	100,5	138	300	130,5	24	G 1 1/2	60	8,5	85	14	25	9,213

G4K ANSI/ASME B1.20.1 NPT

Standard

TYPE	PN	DN	A	B	C	D	E	F	ØG	H	I	L	ØM	CH	ØK	Y	SW	LW	KG
G4K N 1/4	50 MPa	6	42	21,5	100	70	11	56,5	-	110	97,5	15,5	N 1/4	24	6,5	55	9	6	1,767
G4K N 3/8	50 MPa	10	53	28,5	115	80	14	71,5	-	180	101	15,5	N 3/8	30	6,5	65	14	10	3,018
G4K N 1/2	40 MPa	13	62	33	136	100	14	80,5	-	180	110	17	N 1/2	41	8,5	80	14	13	5,247
G4K N 3/4	35 MPa	20	68	36	156	113	14	86,5	-	300	116,5	21	N 3/4	41	8,5	85	14	20	6,898
G4K N 1	35 MPa	25	82	47,5	181	118	14	100,5	138	300	130,5	24	N 1	50	8,5	85	14	25	9,005
G4K N 1 1/4 R	35 MPa	25	82	47,5	181	118	14	100,5	138	300	130,5	24	N 1 1/4	55	8,5	85	14	25	8,989
G4K N 1 1/2 R	35 MPa	25	82	47,5	181	118	14	100,5	138	300	130,5	24	N 1 1/2	60	8,5	85	14	25	9,213

+ G4K

4-WAY HIGH PRESSURE BALL VALVES

www.gemels.it

Standard schemes

L scheme G4 K01

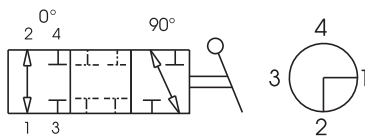

G4K DIN ISO 228 BSP Standard

CARBON STEEL	
ØLW-K01	ITEM CODE G4K01
6	G24GGT15011A000
10	G24GGT25011A000
13	G24GGT34011A000
19	G24GGT43011A000
23	G24GGT53011A000
23	G24GGR63011A000
23	G24GGR73011A000

G4K ANSI/ASME B1.20.1 NPT Standard

CARBON STEEL	
ØLW-K01	ITEM CODE G4K01
6	G24NNT15011A000
10	G24NNT25011A000
13	G24NNT34011A000
19	G24NNT43011A000
23	G24NNT53011A000
23	G24NNR63011A000
23	G24NNR73011A000

T scheme G4 K13

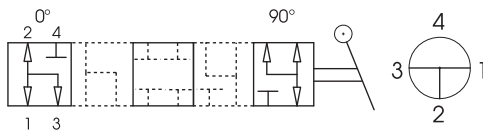

ØLW-K13	ITEM CODE G4K13
6	G2DGGT15011A000
10	G2DGGT25011A000
13	G2DGGT34011A000
19	G2DGGT43011A000
23	G2DGGT53011A000
23	G2DGGR63011A000
23	G2DGGR73011A000

ØLW-K13	ITEM CODE G4K13
6	G2DNNT15011A000
10	G2DNNT25011A000
13	G2DNNT34011A000
19	G2DNNT43011A000
23	G2DNNT53011A000
23	G2DNNR63011A000
23	G2DNNR73011A000

X scheme G4 K14

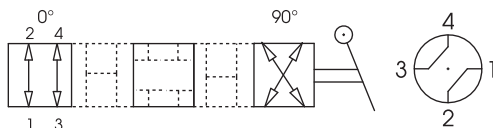

ØLW-K14	ITEM CODE G4K14
5	G2EGGT15011A000
7	G2EGGT25011A000
10	G2EGGT34011A000
15	G2EGGT43011A000
17	G2EGGT53011A000
17	G2EGGR63011A000
17	G2EGGR73011A000

ØLW-K14	ITEM CODE G4K14
5	G2ENNT15011A000
7	G2ENNT25011A000
10	G2ENNT34011A000
15	G2ENNT43011A000
17	G2ENNT53011A000
17	G2ENNR63011A000
17	G2ENNR73011A000

Special schemes on request

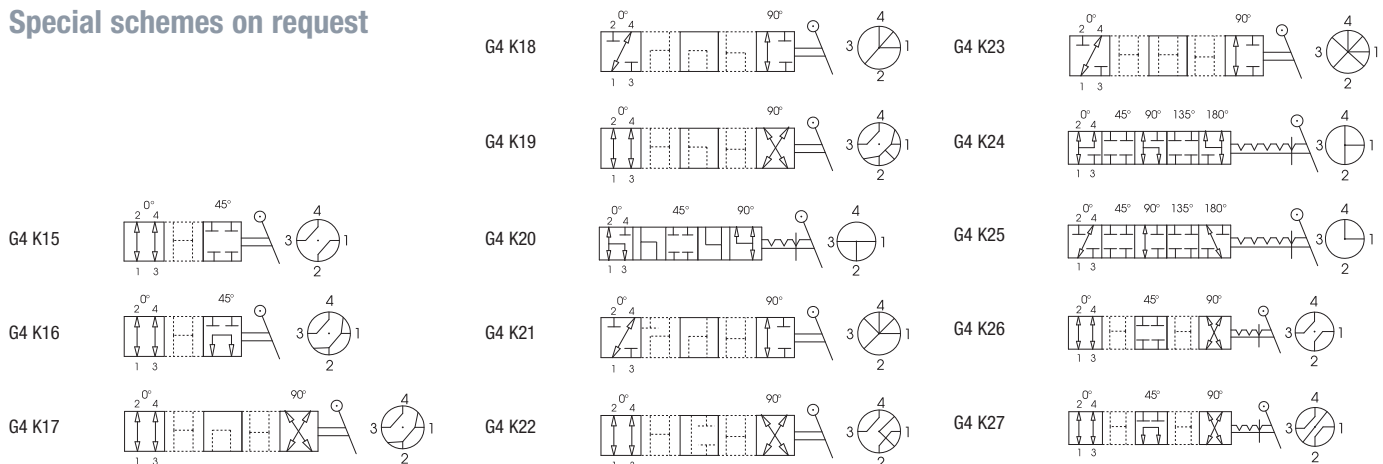

"The company reserves the right to operate dimensional changes without prior notice".



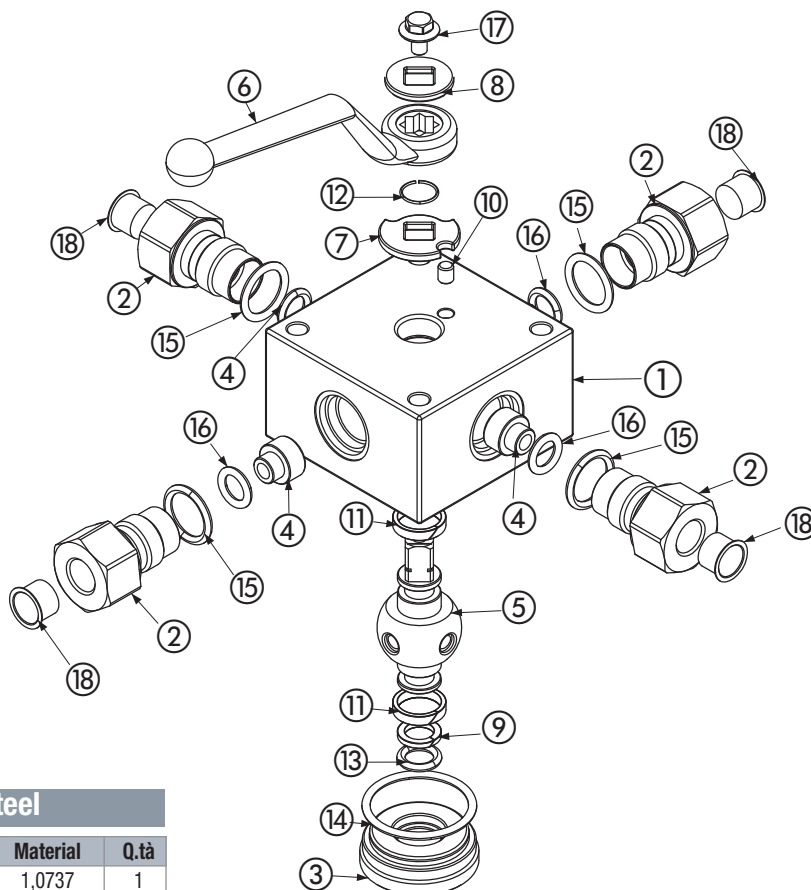

Carbon steel

Pos	Description	Material	Q.tà
1	Body	1,0737	1
2	Adapter	1,0737	4
3	Stemball adapter	1,0737	1
4	Ball Seat	POM	4
5	Ball stem	1,0737	1
6	Handle	ZINC	1
7	Washer	1,0116	1
8	Washer	1,0116	1
9	Stemball ring	PTFE	2
10	Spine	1,0737	1
11	Body ring	PTFE	2
12	Seeger	1,4301	1
13	Stemball o-ring	NBR	2
14	Body o-ring	NBR	1
15	Adapter o-ring	NBR	4
16	Seal o-ring	NBR	4
17	Screw	DIN 6921 8.8	1
18	Caps	PVC	4

For further special requests please consult our technical/commercial service

On request

- Reduced bore
- O-Ring in FKM, EPDM, HNBR, KALREZ
- Seals in PTFE, PEEK, PA612, GEMPTFE, METAL TO METAL
- Special threads
- Pressure class up to PN50 MPa
- Pneumatic and electrical actuator
- Locking device

GPK

GPK2 - GPK3



TECH
MATERIAL

KITS
LOCKING - HANDLES
FLANGE - LIMIT SWITCHES
ACTUATORS - SEALS KITS

OIL&GAS
GM1-GM - GN
SBF - SBT

OTHER
GHP - GPS - RF
BD - VU - VUBA

GR
GRC - GRS

GPK
GPK2 - GPK3

G3K-4K
G3K - G4K

GV
GV2 - GV3

GB
GB2 - GB3 - GBF
GBS - GBC

GE
GEM - GE1 - GE2 - GE3
GE5 - GE3K - GEF
GES - GEC - GEV

+ GPK2

2-WAY HIGH PRESSURE BALL VALVES

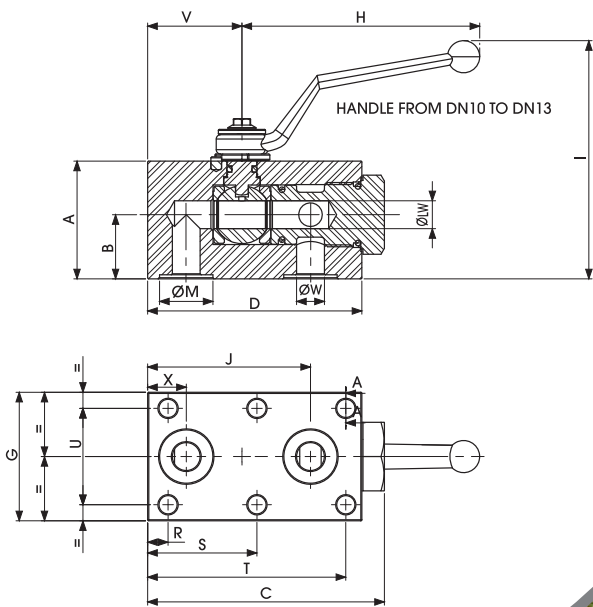

CARBON STEEL

- Type: ball valve GPK 2 way
- Body: square
- Material: 1,0737
- Ball seats: from DN6 up to DN50
- O-Rings: NBR, FKM
- Operating pressure: 500 Bar depending on valve size and seal materials selected
- Temp range: -20°C to +100°C depending on seal material selected

GPK2	DN13	1	1	1	1	A	B
Type and way of valve	Nominal dimension	Body material	Adapter material	Stem material	Ball material	Ball seat material	Adapter and stem seal material
GPK 2-way	DN6 DN10 DN13 DN20 DN25 DN32 DN40 DN50	1 1,0737	1 1,0737	1 1,0737	1 1,0737	A POM D PEEK G PA612 K GEMPTFE C PTFE	B NBR E FKM



GPK2

2-WAY HIGH PRESSURE BALL VALVES

Specialist in Ball Valves

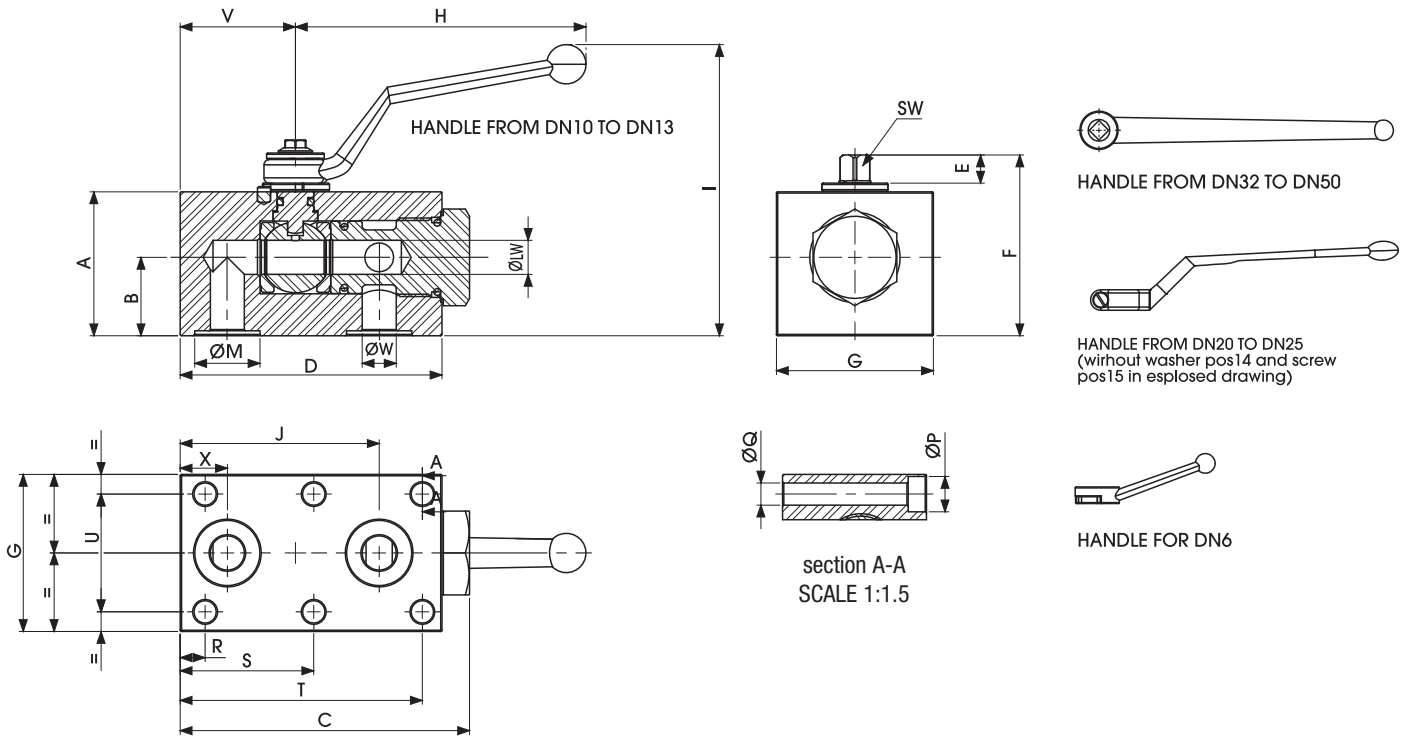

GPK2

Standard

CARBON STEEL

TYPE	PN	DN	A	B	C	D	E	F	G	H	I	ØM	ØW	X	J	ØP	ØQ	R	S	T	U	V	SW	ØLW	Kg	ITEM CODE
GPK2	50 MPa	6	35	22,5	64,5	58	7,5	42,5	40	60	61	11,8	6	9,5	44,5	10,5	6,5	9	-	44	27	26,5	6	6	0,593	GP200T15011A000
GPK2	50 MPa	10	45	22,5	79,5	70	11	59	55	110	101	14,9	9,8	10	54	13,5	8,5	7,5	-	62,5	40	28,75	9	10	1,304	GP200T25011A000
GPK2	40 MPa	13	55	30	110,5	100	11	69	60	110	111	24,9	13	18	76	13,5	8,5	9,5	51	92,5	45	44	9	13	2,387	GP200T34011A000
GPK2	35 MPa	20	70	38,5	129	118	14	88,5	70	180	121,5	29	20	21	90	16,5	10,5	11,5	60	108,5	51	52	14	20	4,079	GP200T43011A000
GPK2	35 MPa	25	79,5	44	146	135	14	98	80	180	131	34,9	25	24	105	16,5	10,5	9	66,5	124	60	61,25	14	25	5,883	GP200T53011A000
GPK2	35 MPa	32	105,5	58,75	183,5	165	14	124	100	300	124	39,7	32	28	124	19	13	11	79	147	78	74	17	32	12,169	GP200T63011A000
GPK2	35 MPa	40	115	61,25	201,5	185	14	133,5	130	300	134	47,7	37	29	141	25	16,5	29	85	141	95	85	17	40	18,624	GP200T73011A000
GPK2	35 MPa	50	129	72	256,5	240	14	147	150	300	147,5	59,8	48	38	174	31	21	38	106	174	112	106	17	48	30,644	GP200T83011A000

+ GPK2 2-WAY HIGH PRESSURE BALL VALVES

www.gemels.it

DRILLING PATTERN FOR DN6 TO DN10

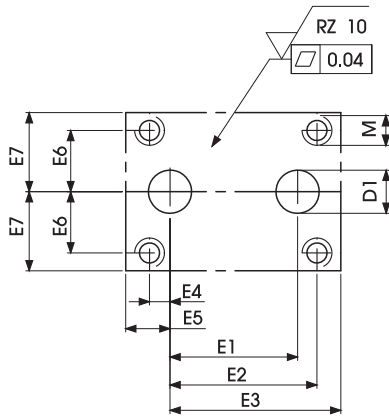

DRILLING PATTERN FOR DN6 TO DN10

DN	D1	E1	E2	E3	E4	E5	E6	E7	M	O-RING
6	6	35	34,5	48,5	0,5	9,5	13,5	20	M6	7.59 x 2.62
10	9,5	44	52,5	60	2,5	10	20	27,5	M8	10.3 x 2.4

DRILLING PATTERN FOR DN13 TO DN50

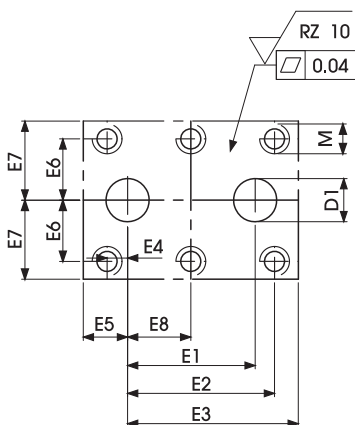

DRILLING PATTERN FOR DN13 TO DN50

DN	D1	E1	E2	E3	E4	E5	E6	E7	E8	M	O-RING
13	13	58	74,5	82	8,5	18	22,5	30	33	M8	20.64 x 2.62
20	20	69	87,5	97	9,5	21	25,5	35	39	M10	23.81 x 2.62
25	25	81	100	111	15	24	30	40	43	M10	29 x 3
32	32	96	119	137	17	28	78	50	51	M12	34.59 x 2.62
40	37	##	112	156	0	29	47,5	65	56	M16	42 x 3
50	48	##	136	202	0	38	56	75	68	M20	54 x 3



+ GPK2 2-WAY HIGH PRESSURE BALL VALVES

Specialist in Ball Valves

2015 - Edition 1

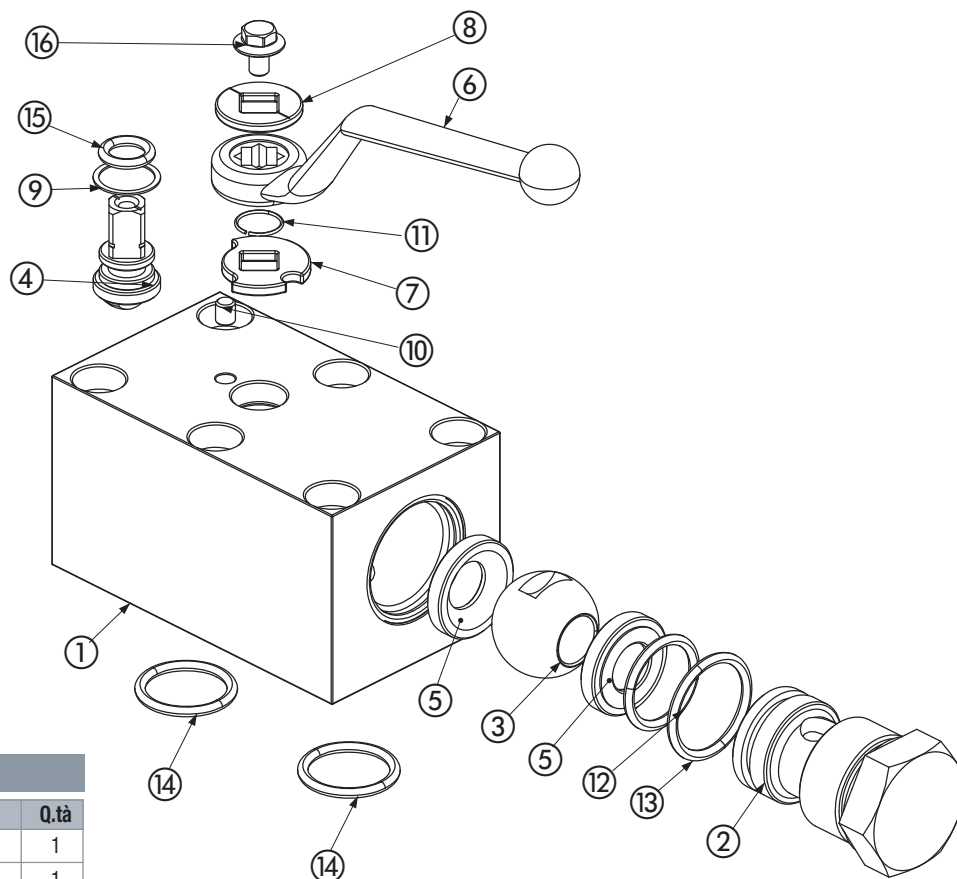

Carbon steel

Pos	Description	Material	Q.tà
1	Body	1,0737	1
2	Adapter	1,0737	1
3	Ball	1,0737	1
4	Stem	1,0737	1
5	Ball seat	POM	2
6	Handle	ZINC	1
7	Washer	1,0116	1
8	Washer	1,0116	1
9	Stem ring	POM	1
10	Spine	1,0737	1
11	Seeger	1,4301	1
12	Adapter o-ring	NBR	1
13	Adapter o-ring	NBR	1
14	Body o-ring	NBR	2
15	Stem o-ring	NBR	1
16	Screw	Din 6921 8.8	1

On request

- Reduced bore
- O-Ring in FKM
- Seals in PTFE, PEEK, PA612, GEMPTFE, METAL TO METAL
- Stem in stainless steel 1,4404
- Ball in stainless steel 1,4404
- Pressure class up to PN50 Mpa
- Pneumatic and electrical actuator
- Locking device

• For further special requests please consult our technical/commercial service

"The company reserves the right to operate dimensional changes without prior notice".

+ GPK3

3-WAY HIGH PRESSURE BALL VALVES

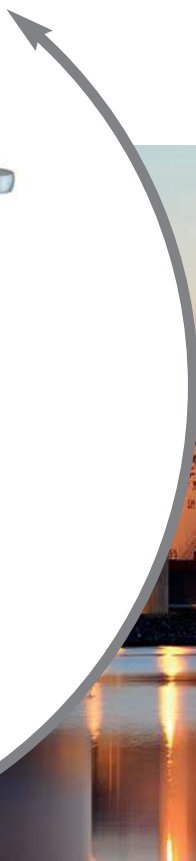

GPK3

CARBON STEEL

- Type: ball valve GPK 3 way
- Body: square
- Material: 1,0737
- Ball seats: from DN6 up to DN50
- O-Rings: NBR, FKM
- Operating pressure: 500 Bar depending on valve size and seal materials selected
- Temp range: -20°C to +100°C depending on seal material selected

GPK3	DN13	1	1	1	1	A	B
Type and way of valve	Nominal dimension	Body material	Adapter material	Stem material	Ball material	Ball seat material	Adapter and stem seal material
GPK 3-way	DN6 DN10 DN13 DN20 DN25 DN32 DN40 DN50	1 1,0737	1 1,0737	1 1,0737	1 1,0737	A POM D PEEK G PA612 K GEMPTFE C PTFE	B NBR E FKM



GPK3

3-WAY HIGH PRESSURE BALL VALVES

Specialist in Ball Valves

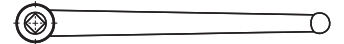
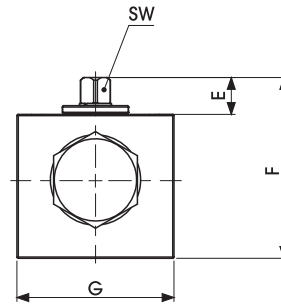
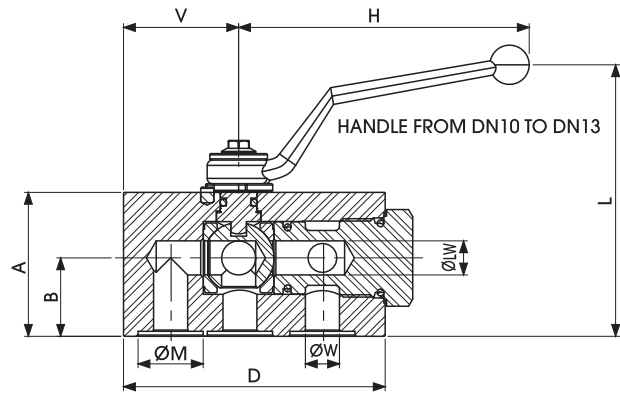

HANDLE FROM DN32 TO DN50



HANDLE FROM DN20 TO DN25
(without washer pos14 and screw pos15 in exploded drawing)

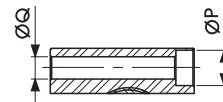
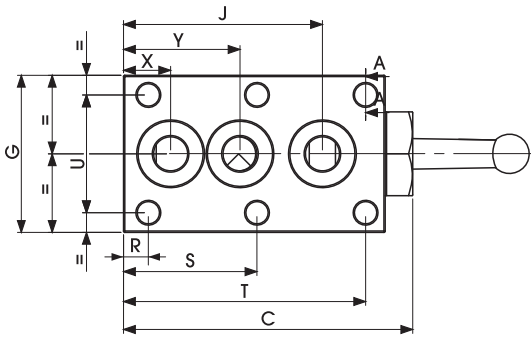

section A-A
SCALE 1:1.5



HANDLE FOR DN6

GPK3

Standard

CARBON STEEL

TYPE	PN	DN	A	B	C	D	E	F	G	H	I	ØM	ØW	X	J	Y	ØP	ØQ	R	S	T	U	V	SW	ØLW	Kg	ITEM CODE
GPK3	50 MPa	6	35	22,5	65	58	7,5	42,5	40	110	61	11,8	6	9,5	44,5	27	10,5	6,5	9	-	44	27	26,5	6	6	0,593	GP300T15011A000
GPK3	50 MPa	10	45	22,5	80	70	11	59	55	110	101	14,9	9,8	10	54	29	13,5	8,5	7,5	-	62,5	40	28,75	9	10	1,304	GP300T25011A000
GPK3	40 MPa	13	55	30	111	100	11	69	60	110	111	24,9	13	18	76	44,5	13,5	8,5	9,5	51	92,5	45	44	9	13	2,387	GP300T34011A000
GPK3	35 MPa	20	70	38,5	129	118	14	88,5	70	180	121,5	29	20	21	90	52	16,5	10,5	11,5	60	108,5	51	52	14	20	4,079	GP300T43011A000
GPK3	35 MPa	25	80	44	146	135	14	98	80	180	131	34,9	25	24	105	62	16,5	10,5	9	66,5	124	60	61,25	14	25	5,883	GP300T53011A000
GPK3	35 MPa	32	106	58,8	184	165	14	124	100	300	124	39,7	32	28	124	74	19	13	11	79	147	78	74	17	32	12,169	GP300T63011A000
GPK3	35 MPa	40	115	61,3	202	185	14	133,5	130	300	134	47,7	37	29	141	85	25	16,5	29	85	141	95	85	17	40	18,624	GP300T73011A000
GPK3	35 MPa	50	129	72	257	240	14	147	150	300	147,5	59,8	48	38	174	106	31	21	38	106	174	112	106	17	48	30,644	GP300T83011A000

+ GPK3 3-WAY HIGH PRESSURE BALL VALVES

www.gemels.it

DRILLING PATTERN FOR DN6 TO DN10

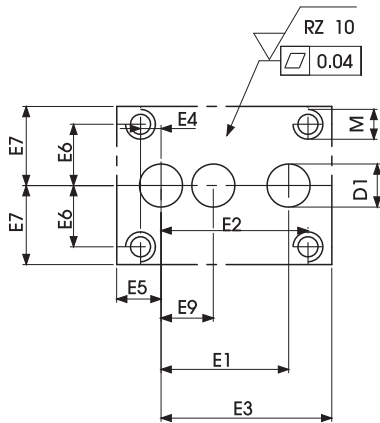

DRILLING PATTERN FOR DN6 TO DN10

DN	D1	E1	E2	E3	E4	E5	E6	E7	E9	M	O-RING
6	6	35	34,5	48,5	0,5	9,5	13,5	20	17,5	M6	7.59 x 2.62
10	9,5	44	52,5	60	2,5	10	20	27,5	19	M8	10.3 x 2.4

GPK3

DRILLING PATTERN FOR DN13 TO DN50

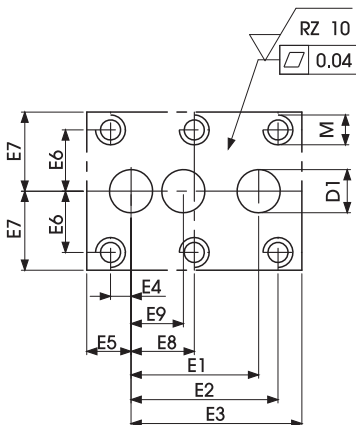

DRILLING PATTERN FOR DN13 TO DN50

DN	D1	E1	E2	E3	E4	E5	E6	E7	E8	E9	M	O-RING
13	13	58	74,5	82	8,5	18	22,5	30	33	27	M8	20.64 x 2.62
20	20	69	87,5	97	9,5	21	25,5	35	39	31	M10	23.81 x 2.62
25	25	81	100	111	15	24	30	40	43	38	M10	29 x 3
32	32	96	119	137	17	28	78	50	51	46	M12	34.59 x 2.62
40	37	112	112	156	0	29	47,5	65	56	56	M16	42 x 3
50	48	136	136	202	0	38	56	75	68	68	M20	54 x 3

+ GPK3 3-WAY HIGH PRESSURE BALL VALVES

Specialist in Ball Valves

2016 - Edition 2

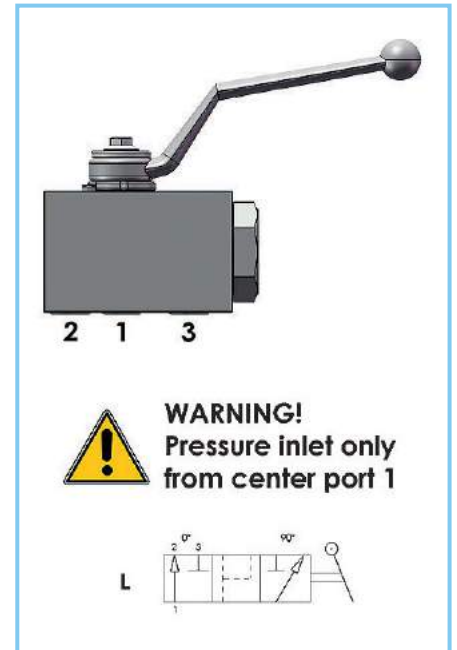
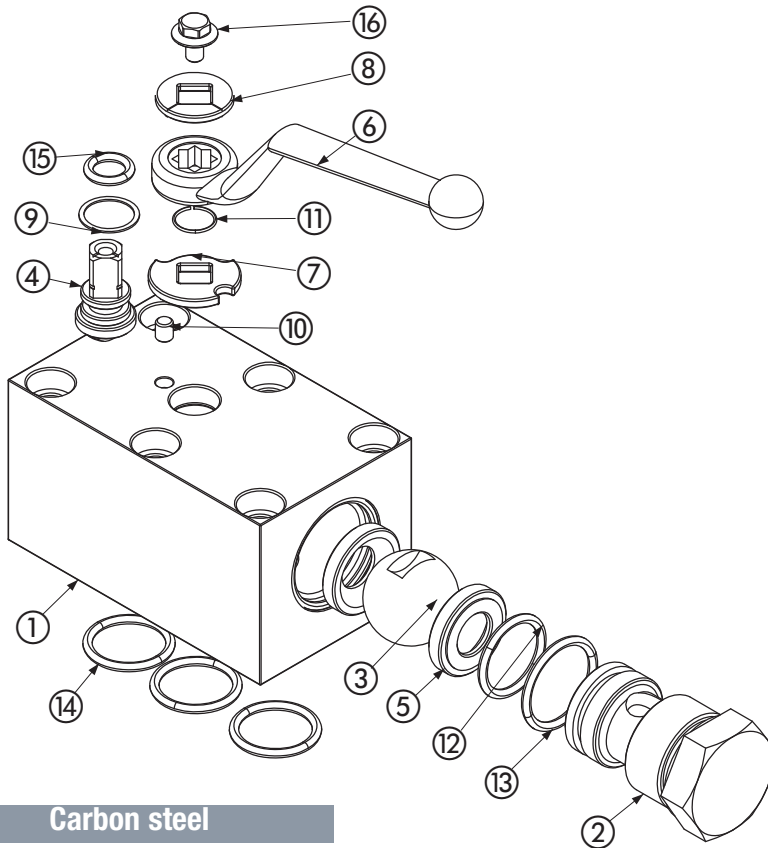

Carbon steel

Pos	Description	Material	Q.tà
1	Body	1,0737	1
2	Adapter	1,0737	1
3	Ball	1,0737	1
4	Stem	1,0737	1
5	Ball seat	POM	2
6	Handle	ZINC	1
7	Washer	1,0116	1
8	Washer	1,0116	1
9	Stem ring	POM	1
10	Spine	1,0737	1
11	Seeger	1,4301	1
12	Adapter o-ring	NBR	1
13	Adapter o-ring	NBR	1
14	Body o-ring	NBR	3
15	Stem o-ring	NBR	1
16	Screw	Din 6921 8.8	1

On request

- Reduced bore
- O-Ring in FKM
- Seals in PTFE, PEEK, PA612, GEMPTFE, METAL TO METAL
- Stem in stainless steel 1,4404
- Ball in stainless steel 1,4404
- Pressure class up to PN50 Mpa
- Pneumatic and electrical actuator
- Locking device

• For further special requests please consult our technical/commercial service

"The company reserves the right to operate dimensional changes without prior notice".

GR

GRC - GRS



TECH
MATERIAL

KITS

LOCKING - HANDLES
FLANGE - LIMIT SWITCHES
ACTUATORS - SEALS KITS

OIL&GAS

GM1-GM - GN
SBF - SBT

OTHER

GHP - GPS - RF
BD - VU - VUBA

GR

GRC - GRS

GPK

GPK2 - GPK3

G3K-4K

G3K - G4K

GV

GV2 - GV3

GB

GB2 - GB3 - GBF
GBS - GBC

GE

GEM - GE1 - GE2 - GE3
GE5 - GE3K - GEF
GES - GEC - GEV

+ GRC

2-WAY HIGH PRESSURE BALL VALVES



GRC

CARBON STEEL

- Type: ball valve GRC 2 way
- Body: round
- Material: 1,0570/1,0570 (FOR STEM 1,4542)
- Ball seats: from DN80 up to DN125
- O-Rings: NBR, FKM, EPDM, MVQ
- Operating pressure: PN250-PN350-PN400 depending on valve size and seal materials selected
- Temp range: -20°C to +100°C depending on seal material selected

GRC	250	DN51	2	2	M	2	A	B
Type and way of valve GRC 2-way	Valves dimension of pressure (psi) PN250 PN350 PN400	Nominal dimension DN25 DN32 DN38 DN40 DN50 DN51 DN56 DN63 DN65 DN80 DN100 DN125	Body material 2 1,0570	Adapter material 2 1,0570	Stem material M 1,4542	Ball material 2 1,0570	Ball seat material A POM D PEEK G PA612 K GEMPTFE C PTFE	Adapter and stem seal material B NBR E FKM F EPDM L MVQ

STAINLESS STEEL

- Type: ball valve GRC 2 way
- Body: round
- Material: 1,4404/1,4404 (FOR STEM 1,4542)
- Ball seats: from DN80 up to DN125
- O-Rings: NBR, FKM, EPDM, MVQ
- Operating pressure: PN250-PN350-PN400 depending on valve size and seal materials selected
- Temp range: -30°C to +100°C different temperatures on request

GRC	250	DN51	4	4	M	4	A	B
Type and way of valve GRC 2-way	Valves dimension of pressure (psi) PN250 PN350 PN400	Nominal dimension DN25 DN32 DN38 DN40 DN50 DN51 DN56 DN63 DN65 DN80 DN100 DN125	Body material 4 1,4404	Adapter material 4 1,4404	Stem material M 1,4542	Ball material 4 1,4404	Ball seat material A POM D PEEK G PA612 K GEMPTFE C PTFE	Adapter and stem seal material B NBR E FKM F EPDM L MVQ

"The company reserves the right to operate dimensional changes without prior notice".



GRC

2-WAY HIGH PRESSURE BALL VALVES

Specialist in Ball Valves

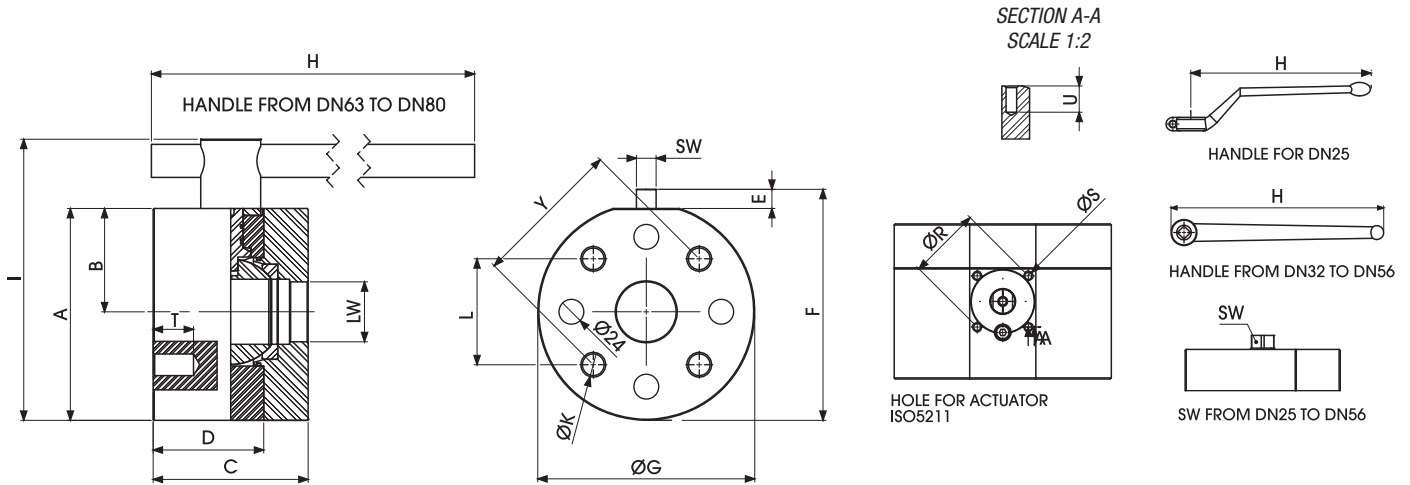

GRC CETOP250 ISO6164

Standard

																				CARBON STEEL	STAINLESS STEEL			
TYPE	PN	DN	A	B	C	D	E	F	ØG	H	I	L	Y	K	ØR	ØS	ISO5211	T	U	SW	LW	KG	ITEM CODE	ITEM CODE
GRC250	25 MPa	25	98,5	39,5	88	69	14	113	118	180	146	43,8	62	4xM10	50	M6	F05	20	10	14	25	6,317	GR2CTT52022A000	GR2CTT52044A000
GRC250	25 MPa	32	143,5	71	100	73	14	162	145	300	171	51,6	73	4xM12	50	M6	F05	21	10	17	32	12,228	GR2CTT6202PA000	GR2CTT6204NA000
GRC250	25 MPa	38	160	78	110	80	14	178,5	165	300	187,5	60,1	85	4xM16	50	M6	F05	24,5	10	17	38	16,867	GR2CTT7202PA000	GR2CTT7204NA000
GRC250	25 MPa	51	192	93	116	90	14	206	196	300	214,5	69,3	98	4xM16	70	M8	F07	25,5	10	17	47	32,855	GR2CTT8202PA000	GR2CTT8204NA000
GRC250	25 MPa	56	192	93	150	107	14	206	203	600	214,5	83,4	118	4xM20	70	M8	F07	33	10	17	58	32,855	GR2CTT9202PA000	GR2CTT9204NA000
GRC250	25 MPa	63	205	100	150	107	18	223	210	600	272	102,5	145	4xM20	70	M8	F07	36	13	19	70	36,569	GR2CTTA202PA000	GR2CTTA204NA000

GRC CETOP350 ISO6164

Standard

																				CARBON STEEL	STAINLESS STEEL			
TYPE	PN	DN	A	B	C	D	E	F	ØG	H	I	L	Y	K	ØR	ØS	ISO5211	T	U	SW	LW	KG	ITEM CODE	ITEM CODE
GRC350	35 MPa	25	102,5	39,5	88	69	14	117	118	180	117	50,9	72	4xM12	50	M6	F05	20	10	14	25	7,2	GR2CTT53022A000	GR2CTT53044A000
GRC350	35 MPa	32	141	68	105	75,5	14	158	145	300	158	56,6	80	4xM16	50	M6	F05	24	10	17	32	12,5	GR2CTT6302PA000	GR2CTT6304NA000
GRC350	35 MPa	40	161	78	110	80	14	178	165	300	178	69,5	98	4xM16	50	M6	F05	25	10	17	38	16,6	GR2CTT7302PA000	GR2CTT7304NA000
GRC350	35 MPa	50	193	94	116	90	14	210	196	300	210	83,5	118	4xM20	70	M8	F07	28	10	17	48	25	GR2CTT8302PA000	GR2CTT8304NA000
GRC350	35 MPa	65	204	100	150	107	21	224	208	600	270	102,5	145	4xM24	70	M8	F07	36	10	19	63	44	GR2CTT9302PA000	GR2CTT9304NA000
GRC350	35 MPa	80	208	100	150	107	22	233,5	215	600	279	123,7	175	4xM30	70	M8	F07	36	13	19	75	45	GR2CTTA302PA000	GR2CTTA304NA000
GRC350	35 MPa	100	251	122	200	147	26,5	277	258	600	327	141,5	200	8xM24	102	M10	F10	40	13	24	95	70	GR2CTTB302PA000	GR2CTTB304NA000
GRC350	35 MPa	125	303	148	220	170	32	330	310	900	389	-	245	8xM30	125	M12	F12	40	13	36	118	109	GR2CTTC302PA000	GR2CTTC304NA000

+ GRC

2-WAY HIGH PRESSURE BALL VALVES

www.gemels.it

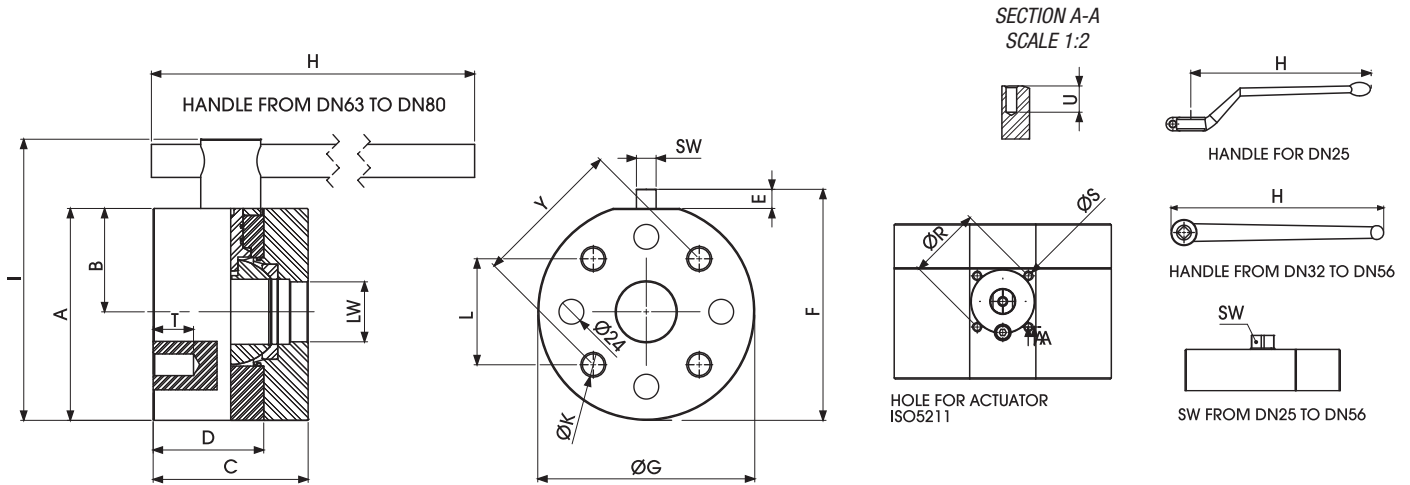

GRC CETOP400 ISO6164

Standard

TYPE	PN	DN	A	B	C	D	E	F	ØG	H	I	L	Y	K	ØR	ØS	ISO5211	T	U	SW	LW	KG	CARBON STEEL	STAINLESS STEEL
																							ITEM CODE	ITEM CODE
GRC400	40 MPa	25	98,5	39,5	88	69	14	113	118	180	146	43,8	62	4xM10	50	M6	F05	20	10	14	25	6,317	GR2CTT54022A000	GR2CTT54044A000
GRC400	40 MPa	32	143,5	71	100	73	14	162	145	300	171	51,6	73	4xM12	50	M6	F05	21	10	17	32	12,228	GR2CTT6402PA000	GR2CTT6404NA000
GRC400	40 MPa	38	160	78	110	80	14	178,5	165	300	187,5	60,1	85	4xM16	50	M6	F05	24,5	10	17	38	16,867	GR2CTT7402PA000	GR2CTT7404NA000
GRC400	40 MPa	51	192	93	116	90	14	206	196	300	214,5	69,3	98	4xM16	70	M8	F07	25,5	10	17	47	32,855	GR2CTT8402PA000	GR2CTT8404NA000
GRC400	40 MPa	56	192	93	150	107	14	206	203	600	214,5	83,4	118	4xM20	70	M8	F07	33	10	17	58	32,855	GR2CTT9402PA000	GR2CTT9404NA000
GRC400	40 MPa	63	205	100	150	107	18	223	210	600	272	102,5	145	4xM24	70	M8	F07	36	13	19	70	36,569	GR2CTTA402PA000	GR2CTTA404NA000
GRC400	40 MPa	80	251	122	170	132	26,5	278	258	600	325	123,7	175	4xM30	102	M10	F10	38	13	24	74	65,411	GR2CTTB402PA000	GR2CTTB404NA000

GRC

+ GRC 2-WAY HIGH PRESSURE BALL VALVES

Specialist in Ball Valves

2016 - Edition 1

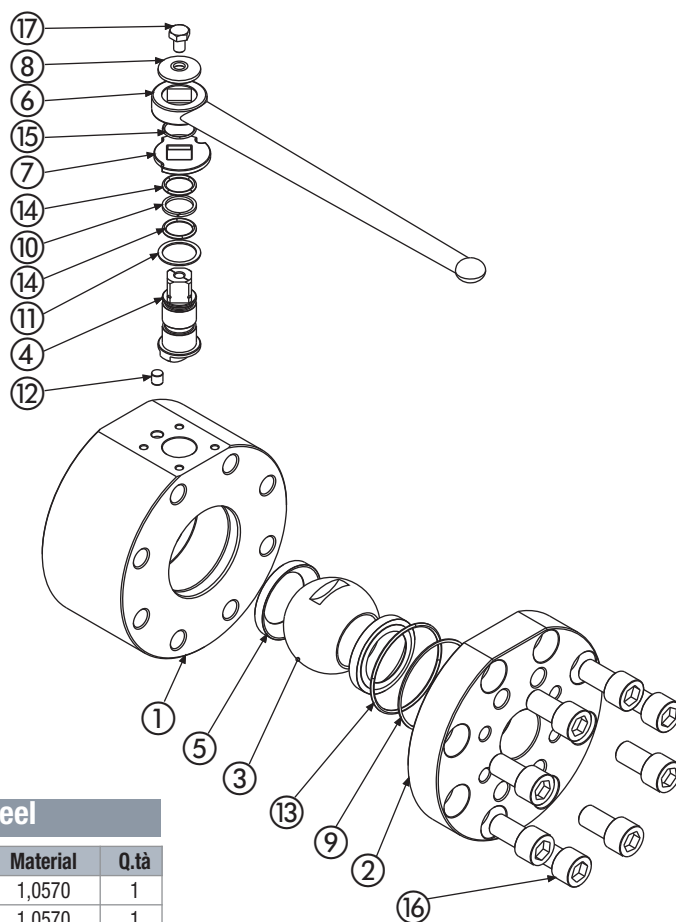

Carbon steel

Pos	Description	Material	Q.tà
1	Body	1,0570	1
2	Flange	1,0570	1
3	Ball	1,0570	1
4	Stem	1,4542	1
5	Seat	POM	2
6	Handle	1,0116	1
7	Washer	1,0116	1
8	Washer	1,0116	1
9	Flange Back-Up	PTFE	1
10	Stem Back-Up	PTFE	1
11	Stem Ring	PTFE	1
12	Pin	1,0737	1
13	Flange o-ring	NBR	1
14	Stem o-ring	NBR	2
15	Seeger	1,4301	1
16	T.C.E.I. Screw	DIN6921 8.8	8
17	T.E. Screw	DIN6921 8.8	1

On request

- Reduced bore
- O-Ring in FKM, EPDM, HNBR, KALREZ
- Seals in PTFE, PEEK, PA612, GEMPTFE, METAL TO METAL
- Special Threads
- Stem in stainless steel 1,4404
- Ball in stainless steel 1,4404
- Pressure class up to PN40 Mpa
- Pneumatic and electrical actuator
- Locking device

Stainless steel

Pos	Description	Material	Q.tà
1	Body	1,4404	1
2	Flange	1,4404	1
3	Ball	1,4404	1
4	Stem	1,4542	1
5	Seat	POM	2
6	Handle	1,0116	1
7	Washer	1,0116	1
8	Washer	1,0116	1
9	Flange Back-Up	PTFE	1
10	Stem Back-Up	PTFE	1
11	Stem Ring	PTFE	1
12	Pin	1,4404	1
13	Flange o-ring	NBR	1
14	Stem o-ring	NBR	2
15	Seeger	1,4301	1
16	T.C.E.I. Screw	ISO4762 A2	8
17	T.E. Screw	ISO4762 A2	1

On request

- Reduced bore
- O-Ring in FKM, EPDM, HNBR, KALREZ
- Seals in PTFE, PEEK, PA612, GEMPTFE, METAL TO METAL
- Special Threads
- Pressure class up to PN40 Mpa
- Pneumatic and electrical actuator
- Locking device

For further special requests please consult our technical/commercial service

+ GRS

2-WAY HIGH PRESSURE BALL VALVES



GRS

CARBON STEEL

- Type: ball valve GR 2 way
- Body: round
- Material: 1,0570/1,0570 (STEM IN 1,4542)
- Ball seats: from DN13 up to DN125
- O-Rings: NBR, FKM, EPDM, MVQ
- Operating pressure: S3000 (210 bar)
S6000 (420 bar) depending on valve size and seal materials selected
- Temp range: -20°C to +100°C depending on seal material selected

GR	S3	DN50	2	2	M	2	A	B
Type and way of valve GR 2-way	Valves dimension of pressure (psi) S3 S6	Nominal dimension	Body material	Adapter material	Stem material	Ball material	Ball seat material	Adapter and stem seal material
	S3000 S6000	DN13 DN20 DN25 DN32 DN40 DN50 DN65 DN80 DN100 DN125	2 1,0570	2 1,0570	M 1,4542	2 1,0570	A POM D PEEK G PA612 K GEMPTFE C PTFE	B NBR E FKM F EPDM L MVQ

STAINLESS STEEL

- Type: ball valve GR 2 way
- Body: round
- Material: 1,4404/1,4404 (FOR STEM 1,4542)
- Ball seats: from DN13 up to DN125
- O-Rings: NBR, FKM, EPDM, MVQ
- Operating pressure: S3000 (210 bar)
S6000 (420 bar) depending on valve size and seal materials selected
- Temp range: -30°C to +100°C different temperatures on request

GR	S3	DN50	4	4	M	4	A	B
Type and way of valve GR 2-way	Valves dimension of pressure (psi) S3 S6	Nominal dimension	Body material	Adapter material	Stem material	Ball material	Ball seat material	Adapter and stem seal material
	S3000 S6000	DN13 DN20 DN25 DN32 DN40 DN50 DN65 DN80 DN100 DN125	4 1,4404	4 1,4404	M 1,4542	4 1,4404	A POM D PEEK G PA612 K GEMPTFE C PTFE	B NBR E FKM F EPDM L MVQ

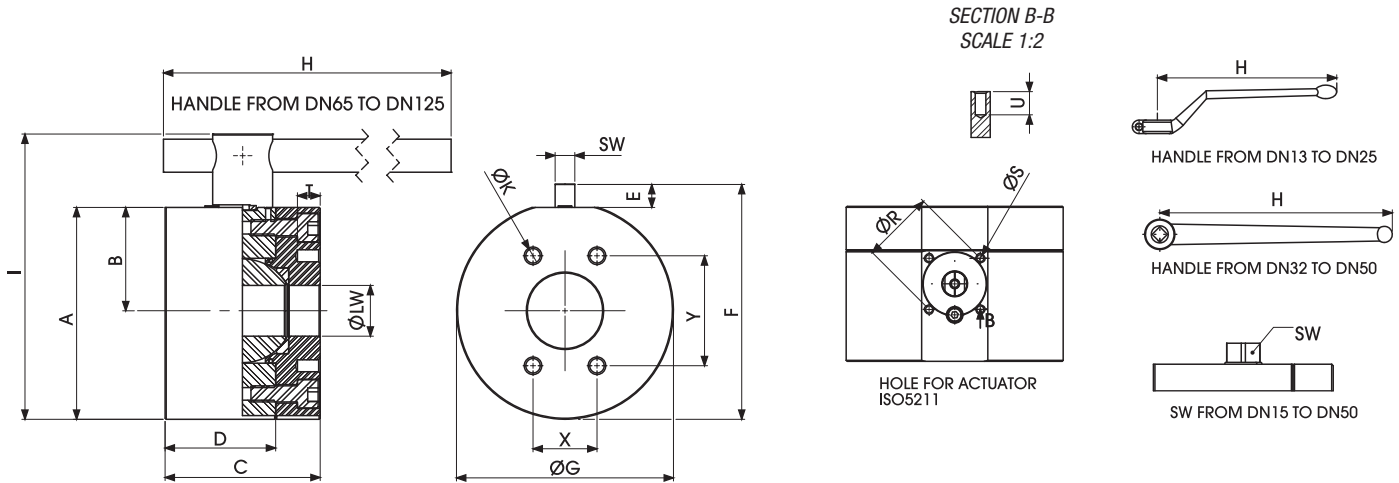

GRS SAE J518 S3000

Standard

TYPE	PN	DN	A	B	C	D	E	F	ØG	H	I	Y	X	ØK	ØR	ØS	ISO5211	T	U	SW	ØLW	KG	CARBON STEEL	STAINLESS STEEL
																							ITEM CODE	ITEM CODE
GRS3	21 MPa	13	67	28	75	58	11	78,3	78	110	78,5	38,1	17,48	M8	36	M5	F03	18	10	9	13	2,405	GR2FT3F022A000	GR2FT3F044A000
GRS3	21 MPa	20	85,5	36,5	80	60	14	100	103	180	103	47,6	22,2	M10	50	M6	F05	18	10	14	20	3,902	GR2FT4F022A000	GR2FT4F044A000
GRS3	21 MPa	25	98,5	39,5	88	69	14	113	118	180	146	52,4	26,2	M10	50	M6	F05	19	10	14	25	6,317	GR2FT5F022A000	GR2FT5F044A000
GRS3	21 MPa	32	143,5	70,9	100	73	14	162	145	300	171	58,7	30,2	M10	50	M6	F05	20	10	17	32	12,228	GR2FT6F022A000	GR2FT6F044A000
GRS3	21 MPa	40	160	78	110	80	14	178,5	165	300	187,5	69,8	35,7	M12	50	M6	F05	20	10	17	38	16,867	GR2FT7F022A000	GR2FT7F044A000
GRS3	21 MPa	50	192	93	116	90	14	205,5	196	300	214,5	77,8	42,9	M12	70	M8	F07	20	10	17	48	25,606	GR2FT8F022A000	GR2FT8F044A000
GRS3	21 MPa	65	198	93	150	107	20,5	212	203	600	260	88,9	50,8	M12	70	M8	F07	20	13	19	63	32,717	GR2FT9F022A000	GR2FT9F044A000
GRS3	21 MPa	80	205	100	150	107	22	227,5	210	600	279	106,4	61,9	M16	70	M8	F07	24	13	19	73	36,413	GR2FTA022A000	GR2FTA044A000
GRS3	21 MPa	100	251	122	170	132	27	278	258	600	325	130,2	77,9	M16	102	M10	F10	24	13	24	95	61,273	GR2FTB022A000	GR2FTB044A000
GRS3	21 MPa	125	288	140	210	160	35	322	310	600	372,5	152,4	92,1	M16	125	M12	F12	30	17	36	115	98,048	GR2FTCF022A000	GR2FTCF044A000

GRS SAE J518 S3000 UNC

Standard

TYPE	PN	DN	A	B	C	D	E	F	ØG	H	I	Y	X	ØK	ØR	ØS	ISO5211	T	U	SW	ØLW	KG	CARBON STEEL	STAINLESS STEEL
																							ITEM CODE	ITEM CODE
GRS3	21 MPa	13	67	28	75	58	11	78,3	78	110	78,5	38,1	17,48	5/16 UNC	36	M5	F03	18	10	9	13	2,405	GR2FUT3F022A000	GR2FUT3F044A000
GRS3	21 MPa	20	85,5	36,5	80	60	14	100	103	180	103	47,6	22,2	3/8 UNC	50	M6	F05	18	10	14	20	3,902	GR2FUT4F022A000	GR2FUT4F044A000
GRS3	21 MPa	25	98,5	39,5	88	69	14	113	118	180	146	52,4	26,2	3/8 UNC	50	M6	F05	19	10	14	25	6,317	GR2FUT5F022A000	GR2FUT5F044A000
GRS3	21 MPa	32	143,5	70,9	100	73	14	162	145	300	171	58,7	30,2	7/16 UNC	50	M6	F05	20	10	17	32	12,228	GR2FUT6F022A000	GR2FUT6F044A000
GRS3	21 MPa	40	160	78	110	80	14	178,5	165	300	187,5	69,8	35,7	1/2 UNC	50	M6	F05	20	10	17	38	16,867	GR2FUT7F022A000	GR2FUT7F044A000
GRS3	21 MPa	50	192	93	116	90	14	205,5	196	300	214,5	77,8	42,9	1/2 UNC	70	M8	F07	20	10	17	48	25,606	GR2FUT8F022A000	GR2FUT8F044A000
GRS3	21 MPa	65	198	93	150	107	20,5	212	203	600	260	88,9	50,8	1/2 UNC	70	M8	F07	20	13	19	63	32,717	GR2FUT9F022A000	GR2FUT9F044A000
GRS3	21 MPa	80	205	100	150	107	22	227,5	210	600	279	106,4	61,9	5/8 UNC	70	M8	F07	24	13	19	73	36,413	GR2FUTA022A000	GR2FUTA044A000
GRS3	21 MPa	100	251	122	170	132	27	278	258	600	325	130,2	77,9	5/8 UNC	102	M10	F10	24	13	24	95	61,273	GR2FUTB022A000	GR2FUTB044A000
GRS3	21 MPa	125	288	140	210	160	35	322	310	600	372,5	152,4	92,1	5/8 UNC	125	M12	F12	30	17	36	115	98,048	GR2FUTC022A000	GR2FUTC044A000

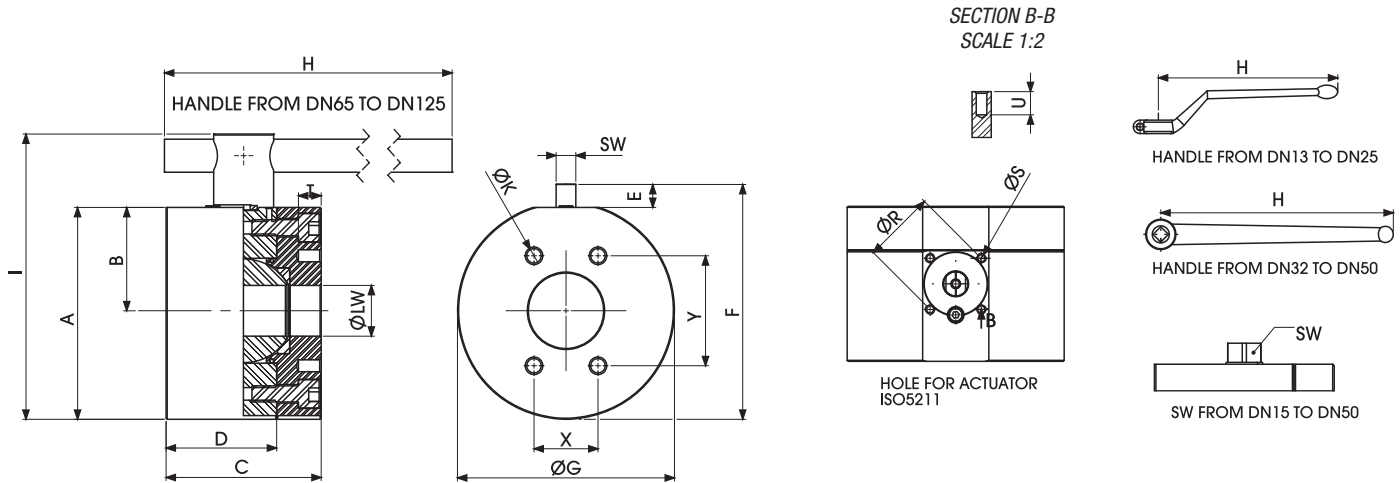

GRS SAE J518 S6000

Standard

TYPE	PN	DN	A	B	C	D	E	F	ØG	H	I	Y	X	ØK	ØR	ØS	ISO5211	T	U	SW	ØLW	KG	CARBON STEEL	STAINLESS STEEL
																							ITEM CODE	ITEM CODE
GRS6	42 MPa	13	67	28	75	58	11	78,3	78	110	78,5	40,49	18,24	M8	36	M5	F03	18	10	9	13	2,405	GR2FFT3G022A000	GR2FFT3G044A000
GRS6	42 MPa	20	85,5	36,5	80	60	14	100	103	180	103	50,8	23,8	M10	50	M6	F05	18	10	14	20	3,902	GR2FFT4G022A000	GR2FFT4G044A000
GRS6	42 MPa	25	98,5	39,5	88	69	14	113	118	180	146	57,2	27,8	M12	50	M6	F05	19	10	14	25	6,317	GR2FFT5G022A000	GR2FFT5G044A000
GRS6	42 MPa	32	143,5	70,9	100	73	14	162	145	300	171	66,7	31,8	M12	50	M6	F05	22	10	17	32	12,228	GR2FFT6G022A000	GR2FFT6G044A000
GRS6	42 MPa	40	160	78	110	80	14	178,5	165	300	187,5	79,4	36,5	M16	50	M6	F05	22	10	17	38	16,867	GR2FFT7G022A000	GR2FFT7G044A000
GRS6	42 MPa	50	192	93	116	90	14	205,5	196	300	214,5	96,8	44,5	M20	70	M8	F07	28	10	17	48	25,606	GR2FFT8G022A000	GR2FFT8G044A000

GRS SAE J518 S6000 UNC

Standard

TYPE	PN	DN	A	B	C	D	E	F	ØG	H	I	Y	X	ØK	ØR	ØS	ISO5211	T	U	SW	ØLW	KG	CARBON STEEL	STAINLESS STEEL
																							ITEM CODE	ITEM CODE
GRS6	42 MPa	13	67	28	75	58	11	78,3	78	110	78,5	40,49	18,24	5/16 UNC	36	M5	F03	18	10	9	13	2,405	GR2FUT3G022A000	GR2FUT3G044A000
GRS6	42 MPa	20	85,5	36,5	80	60	14	100	103	180	103	50,8	23,8	3/8 UNC	50	M6	F05	18	10	14	20	3,902	GR2FUT4G022A000	GR2FUT4G044A000
GRS6	42 MPa	25	98,5	39,5	88	69	14	113	118	180	146	57,2	27,8	7/16 UNC	50	M6	F05	19	10	14	25	6,317	GR2FUT5G022A000	GR2FUT5G044A000
GRS6	42 MPa	32	143,5	70,9	100	73	14	162	145	300	171	66,7	31,8	1/2 UNC	50	M6	F05	22	10	17	32	12,228	GR2FUT6G022A000	GR2FUT6G044A000
GRS6	42 MPa	40	160	78	110	80	14	178,5	165	300	187,5	79,4	36,5	5/8 UNC	50	M6	F05	22	10	17	38	16,867	GR2FUT7G022A000	GR2FUT7G044A000
GRS6	42 MPa	50	192	93	116	90	14	205,5	196	300	214,5	96,8	44,5	3/4 UNC	70	M8	F07	28	10	17	48	25,606	GR2FUT8G022A000	GR2FUT8G044A000

GRS

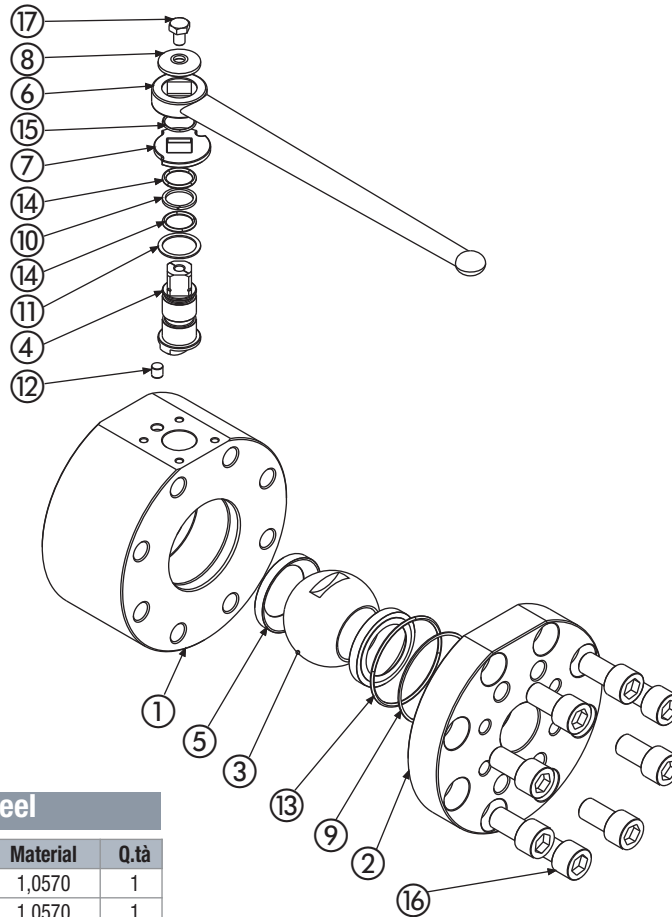

Carbon steel

Pos	Description	Material	Q.tà
1	Body	1,0570	1
2	Flange	1,0570	1
3	Ball	1,0570	1
4	Stem	1,4542	1
5	Seat	POM	2
6	Handle	1,0116	1
7	Washer	1,0116	1
8	Washer	1,0116	1
9	Flange Back-Up	PTFE	1
10	Stem Back-Up	PTFE	1
11	Stem Ring	PTFE	1
12	Pin	1,0737	1
13	Flange o-ring	NBR	1
14	Stem o-ring	NBR	2
15	Seeger	1,4301	1
16	T.C.E.I. Screw	DIN6921 8.8	8
17	T.E. Screw	DIN6921 8.8	1

- On request**
- Reduced bore
 - O-Ring in FKM, EPDM, HNBR, KALREZ
 - Seals in PTFE, PEEK, PA612, GEMPTFE, METAL TO METAL
 - Special Threads
 - Stem in stainless steel 1,4404
 - Ball in stainless steel 1,4404
 - Pressure class up to PN42 Mpa
 - Pneumatic and electrical actuator
 - Locking device

Stainless steel

Pos	Description	Material	Q.tà
1	Body	1,4404	1
2	Flange	1,4404	1
3	Ball	1,4404	1
4	Stem	1,4542	1
5	Seat	POM	2
6	Handle	1,0116	1
7	Washer	1,0116	1
8	Washer	1,0116	1
9	Flange Back-Up	PTFE	1
10	Stem Back-Up	PTFE	1
11	Stem Ring	PTFE	1
12	Pin	1,4404	1
13	Flange o-ring	NBR	1
14	Stem o-ring	NBR	2
15	Seeger	1,4301	1
16	T.C.E.I. Screw	ISO4762 A2	8
17	T.E. Screw	ISO4762 A2	1

- On request**
- Reduced bore
 - O-Ring in FKM, EPDM, HNBR, KALREZ
 - Seals in PTFE, PEEK, PA612, GEMPTFE, METAL TO METAL
 - Special Threads
 - Pressure class up to PN42 Mpa
 - Pneumatic and electrical actuator
 - Locking device

For further special requests please consult our technical/commercial service

OTHER

GHP - GPS - RF - BD - VU - VUBA



TECH
MATERIAL

KITS

LOCKING - HANDLES
FLANGE - LIMIT SWITCHES
ACTUATORS - SEALS KITS

OIL&GAS

GM1-GM - GN
SBF - SBT

OTHER

GHP - GPS - RF
BD - VU - VUBA

GR

GRC - GRS

GPK

GPK2 - GPK3

G3K-4K

G3K - G4K

GV

GV2 - GV3

GB

GB2 - GB3 - GBF
GBS - GBC

GE

GEM - GE1 - GE2 - GE3
GE5 - GE3K - GEF
GES - GEC - GEV

+ GHP

2-WAY HIGH PRESSURE BALL VALVES



CARBON STEEL

- Type: ball valve GHP 2 way
- Body: square
- Material: 1,0570/1,4404
- Ball seats: from DN13 up to DN80
- O-Rings: NBR, FKM, EPDM, MVQ
- Operating pressure: 370 Bar depending on valve size and seal materials selected
- Temp range: -20°C to +100°C depending on seal material selected

GHP	G 1/2	DN13	2	2	4	4	A	B	
Type and way of valve GHP 2-way	GAS DIN/ISO 228 BSP	NPT ANSI/ASME B1.20.1	Nominal dimension	Body material	Adapter material	Stem material	Ball material	Ball seat material	Adapter and stem seal material
	G 1/2	N 1/2	DN13	2 1,0570	2 1,0570	4 1,4404 M 17-4PH	4 1,4404	A POM D PEEK G PA612 K GEMPTFE C PTFE	B NBR E FKM F EPDM L MVQ
	G 3/4	N 3/4	DN20						
	G 1	N 1	DN25						
	G 1 1/4 R	N 1 1/4 R	DN32						
	G 1 1/2 R	N 1 1/2 R	DN40						
	G 2	N 2	DN50						
	G 2 1/2	N 2 1/2	DN65						
	G 3	N 3	DN80						
	G 4	N 4	DN100						

STAINLESS STEEL

- Type: ball valve GHP 2 way
- Body: square
- Material: 1,4404
- Ball seats: from DN13 up to DN80
- O-Rings: NBR, FKM, EPDM, MVQ
- Operating pressure: 370 Bar depending on valve size and seal materials selected
- Temp range: -30°C to +100°C different temperatures on request

GHP	G 1/2	DN13	4	4	4	4	A	B	
Type and way of valve GHP 2-way	GAS DIN/ISO 228 BSP	NPT ANSI/ASME B1.20.1	Nominal dimension	Body material	Adapter material	Stem material	Ball material	Ball seat material	Adapter and stem seal material
	G 1/2	N 1/2	DN13	4 1,4404	4 1,4404	4 1,4404 M 17-4PH	4 1,4404	A POM D PEEK G PA612 K GEMPTFE C PTFE	B NBR E FKM F EPDM L MVQ
	G 3/4	N 3/4	DN20						
	G 1	N 1	DN25						
	G 1 1/4 R	N 1 1/4 R	DN32						
	G 1 1/2 R	N 1 1/2 R	DN40						
	G 2	N 2	DN50						
	G 2 1/2	N 2 1/2	DN65						
	G 3	N 3	DN80						
	G 4	N 4	DN100						



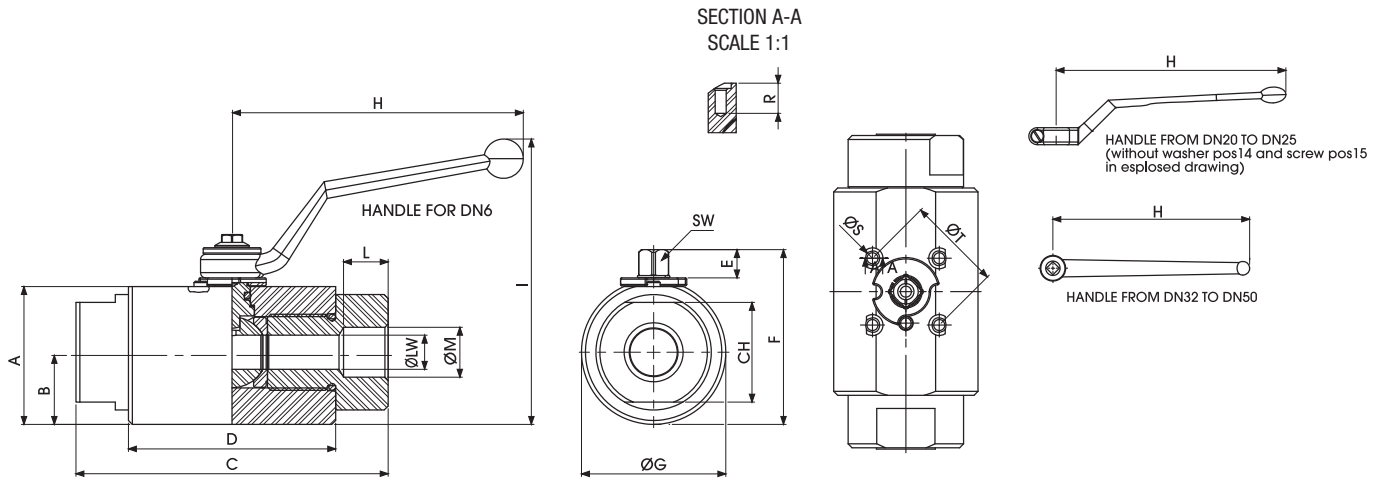

GHP DIN/ISO 228 BSP

Standard

																				CARBON STEEL	STAINLESS STEEL		
TYPE	PN	DN	A	B	C	D	E	F	ØG	H	I	L	ØM	CH	ØT	ISO5211	ØS	R	SW	ØLW	KG	ITEM CODE	ITEM CODE
GHP G 1/2	37 MPa	13	53	27,5	119	79	11	66,5	55	110	102,5	17	G 1/2	38	36	F03	M5	9	9	13	1,81	GH2GGT3H024A000	GH2GGT3H044A000
GHP G 3/4	37 MPa	20	70	38,5	149	99	14	88,6	77	180	118	21	G 3/4	55	50	F05	M6	9	14	20	4,378	GH2GGT4H024A000	GH2GGT4H044A000
GHP G 1	37 MPa	25	80,5	45	168	105	14	99	90	180	129	24	G 1	60	50	F05	M6	9	14	25	6,219	GH2GGT5H024A000	GH2GGT5H044A000
GHP G 1 1/4	37 MPa	32	95	48,5	156	106	14	113	97	300	112	25	G 1 1/4	70	50	F05	M6	9	17	32	6,74	GH2GGT6H024A000	GH2GGT6H044A000
GHP G 1 1/2	37 MPa	40	111,5	58	166,5	110,5	14	130	116	300	128	25	G 1 1/2	75	50	F05	M6	9	17	40	10	GH2GGT7H024A000	GH2GGT7H044A000
GHP G 2	37 MPa	50	118,5	61,5	175	115	14	137	123	300	137	27	G 2	85	50	F05	M6	9	17	49	11,169	GH2GGT8H024A000	GH2GGT8H044A000
GHP G 2 1/2	37 MPa	65	184,5	93,5	211,5	131,5	30,5	223,5	187	600	280	32	G 2 1/2	140	102	F10	M10	20	24	63	36,5	GH2GGT9H02PA000	GH2GGT9H044A000
GHP G 3	37 MPa	80	200	102	239	162,5	30,5	239	204	600	294	32	G 3	140	102	F10	M10	20	24	74	46,5	GH2GGTAH02PA000	GH2GGTAH044A000
GHP G 4	37 MPa	100	236	120	295,5	218	31	268,5	240	450	316,5	38	G 4	170	102	F10	M10	20	24	95	77	GH2GGTBH024A000	GH2GGTBH044A000

+ GHP

2-WAY HIGH PRESSURE BALL VALVES

www.gemels.it

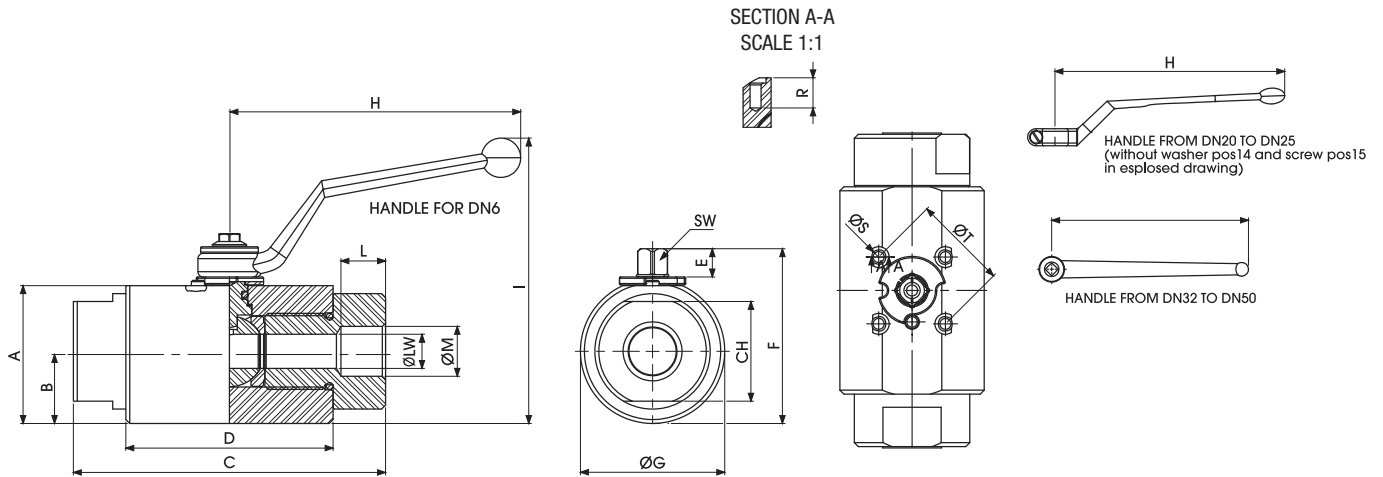

GHP ANSI-ASME B1.20.1 NPT

Standard

																				CARBON STEEL	STAINLESS STEEL		
TYPE	PN	DN	A	B	C	D	E	F	ØG	H	I	L	ØM	CH	ØT	ISO5211	ØS	R	SW	ØLW	KG	ITEM CODE	ITEM CODE
GHP N 1/2	37 MPa	13	53	27,5	119	79	11	66,5	55	110	102,5	17	N 1/2	38	36	F03	M5	9	9	13	1,81	GH2NNT3H024A000	GH2NNT3H044A000
GHP N 3/4	37 MPa	20	70	38,5	149	99	14	88,6	77	180	118	21	N 3/4	55	50	F05	M6	9	14	20	4,378	GH2NNT4H024A000	GH2NNT4H044A000
GHP N 1	37 MPa	25	80,5	45	168	105	14	99	90	180	129	24	N 1	60	50	F05	M6	9	14	25	6,219	GH2NNT5H024A000	GH2NNT5H044A000
GHP N 1 1/4	37 MPa	32	95	48,5	156	106	14	113	97	300	112	25	N 1 1/4	70	50	F05	M6	9	17	32	6,74	GH2NNT6H024A000	GH2NNT6H044A000
GHP N 1 1/2	37 MPa	40	111,5	58	166,5	110,5	14	130	116	300	128	25	N 1 1/2	75	50	F05	M6	9	17	40	10	GH2NNT7H024A000	GH2NNT7H044A000
GHP N 2	37 MPa	50	118,5	61,5	175	115	14	137	123	300	137	27	N 2	85	50	F05	M6	9	17	49	11,169	GH2NNT8H024A000	GH2NNT8H044A000
GHP N 2 1/2	37 MPa	65	184,5	93,5	211,5	131,5	30,5	223,5	187	600	280	32	N 2 1/2	140	102	F10	M10	20	24	63	36,5	GH2NNT9H02PA000	GH2NNT9H044A000
GHP N 3	37 MPa	80	200	102	239	162,5	30,5	239	204	600	294	32	N 3	140	102	F10	M10	20	24	74	46,5	GH2NNTAH02PA000	GH2NNTAH044A000
GHP N 4	37 MPa	100	236	120	295,5	218	31	268,5	240	450	316,5	38	N 4	170	102	F10	M10	20	24	95	77	GH2NNTBH024A000	GH2NNTBH044A000

GHP

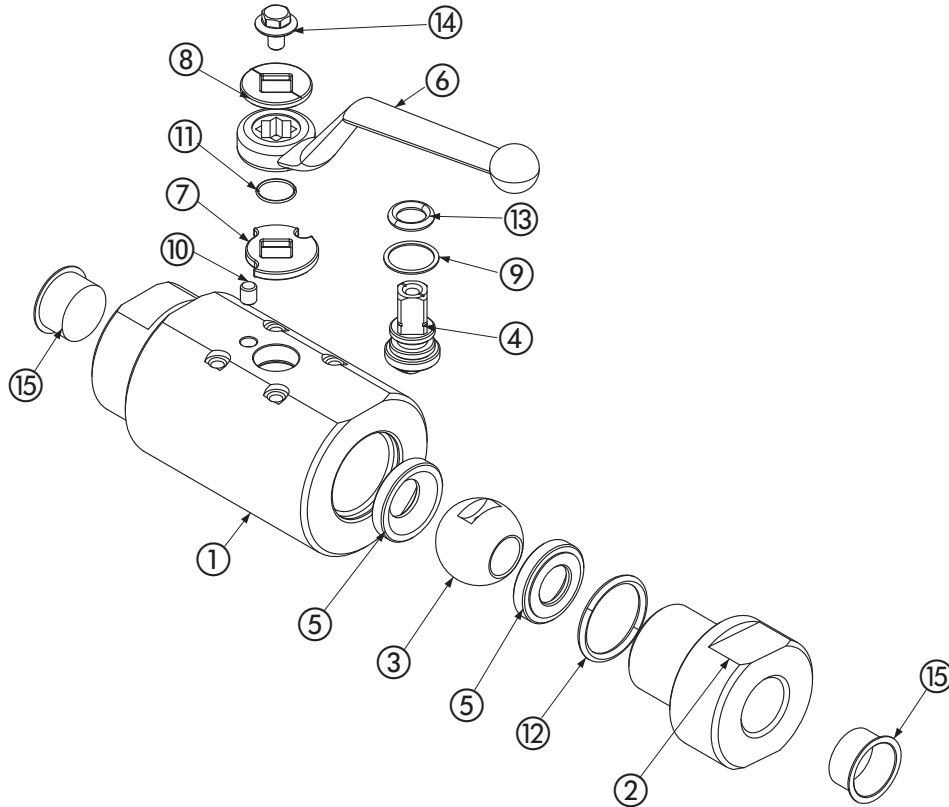

Carbon steel

Pos	Description	Material	Q.tà
1	Body	1,0570	1
2	Adapter	1,0570	1
3	Ball	1,4404	1
4	Stem	1,4404	1
5	Ball seat	POM	2
6	Handle	ZINC	1
7	Washer	1,0116	1
8	Washer	1,0116	1
9	Stem ring	POM	1
10	Spine	1,0737	1
11	Seeger	1,4301	1
12	Adapter o-ring	NBR	1
13	Stem o-ring	NBR	1
14	Screw	Din 6921 8.8	1
15	Caps	PVC	2

On request

- Reduced bore
- O-Ring in FKM, EPDM, HNBR, KALREZ
- Seals in PTFE, PEEK, PA612, GEMPTFE, METAL TO METAL
- Special threads
- Pressure class up to PN37 Mpa
- Pneumatic and electrical actuator
- Locking device

For further special requests please consult our technical/commercial service

Stainless steel

Pos	Description	Material	Q.tà
1	Body	1,4404	1
2	Adapter	1,4404	1
3	Ball	1,4404	1
4	Stem	1,4404	1
5	Ball seat	POM	2
6	Handle	ZINC	1
7	Washer	1,4301	1
8	Washer	1,4301	1
9	Stem ring	POM	1
10	Spine	1,4301	1
11	Seeger	1,4301	1
12	Adapter o-ring	NBR	1
13	Stem o-ring	NBR	1
14	Screw	Din 6921 A2	1
15	Caps	PVC	2

On request

- Reduced bore
- O-Ring in FKM, EPDM, HNBR, KALREZ
- Seals in PTFE, PEEK, PA612, GEMPTFE, METAL TO METAL
- Special threads
- Pressure class up to PN37 Mpa
- Pneumatic and electrical actuator
- Locking device

+ GPS

3 WAYS SINGLE PILOT OPERATED CHECK VALVES

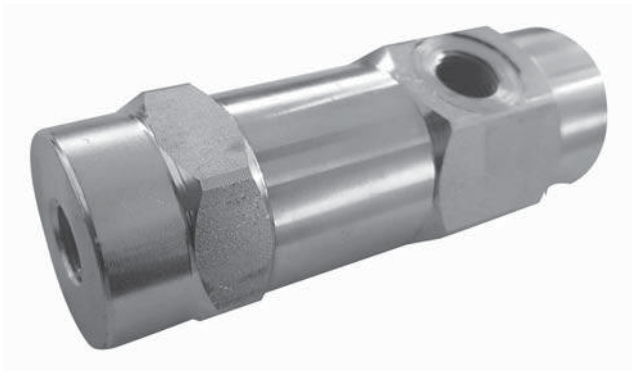

CARBON STEEL

- Type: 3-ways single pilot operated check valves GPS
- Body: zinc-plated steel
- Internal parts: hardened and ground steel
- Seals: NBR standard
- Poppet type: any leakage.
- Oil temperature: 50°C
- Oil viscosity: 30 cSt
- Operating pressure: 350-400 Bar
- Temp range: -20°C to +100°C



GPS	G 1/4	2,5	V
Type and way of valve GPS	Port size	Cracking pressure	Seals hole NBR
	G 1/4	2,5	
	G 3/8	5	
	G 1/2	3	
	G 3/4	0,5	
	G 1	1	



+ GPS 3 WAYS SINGLE PILOT OPERATED CHECK VALVES

Specialist in Ball Valves

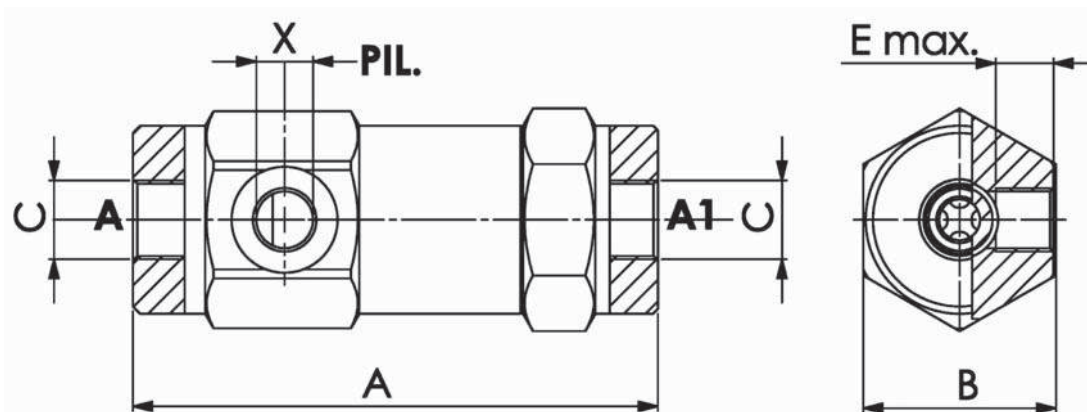

GPS

TYPE	MAXFLOW	MAX PRESSURE	CRACKING PRESSURE	A	B	C	X	E	PILOT RATIO	KG	ITEM CODE
	l/min	BAR		mm	mm	BSPP	BSPP	mm			
GPS G 1/4	12	400	2,5	103	36	1/4	1/4	11	1:9	0,650	G550202A01AARAA
GPS G 3/8	30	400	5	109	40	3/8	1/4	11,5	1:6	0,820	G550203A01AARAA
GPS G 1/2	45	350	3	120	42	1/2	1/4	11	1:4.5	0,960	G550204A01AAPAA
GPS G 3/4	85	350	0,5	131	55	3/4	1/4	14	1:3.7	1,950	G550205A01AAPAA
GPS G 1	120	350	1	165	55	1	1/4	14	1:3.5	2,35	G550206A01AAPAA



+ GPS 3 WAYS SINGLE PILOT OPERATED CHECK VALVES

www.gemels.it

2016 - Edition 1

ON REQUEST:
• 8 Bar spring

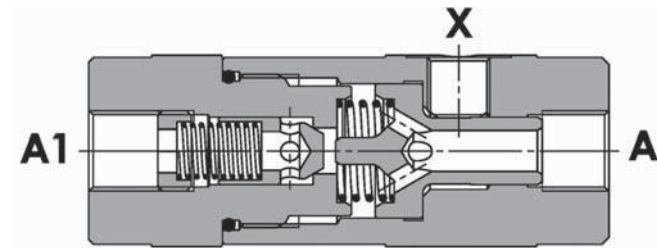
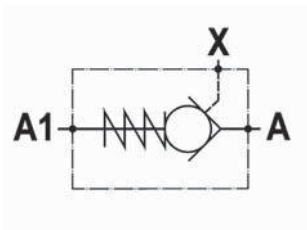

PRESSURE DROP CURVES

Oil viscosity 24 mm²/sec. (3,5°E)
Temperature 50° C

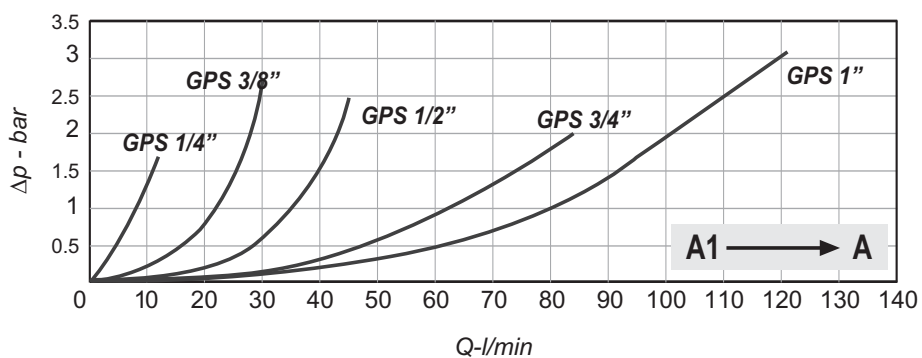
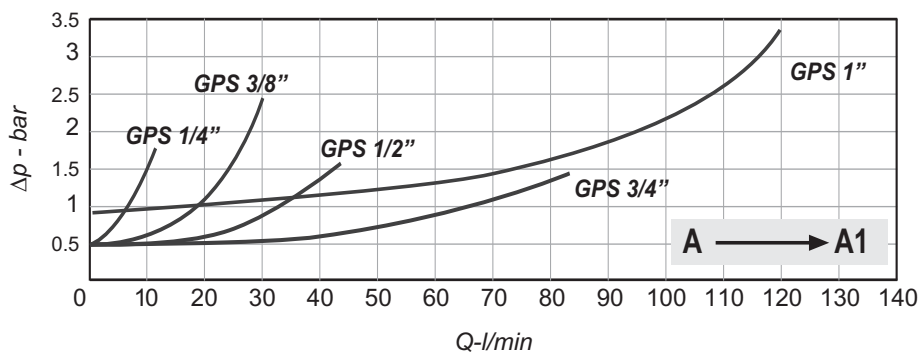

+ RF

FLOW CONTROL

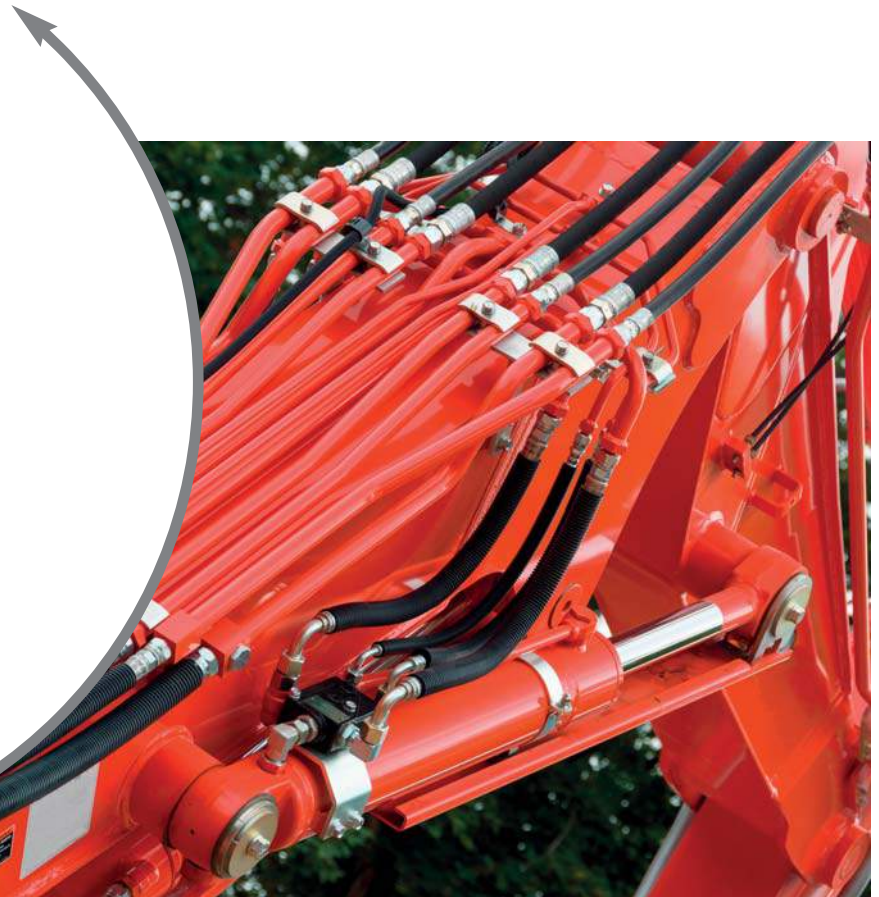

CARBON STEEL

- Type: check valve RF
- Body: square
- Material: 1,0737/1,4749
- Ball seats: from 1/4 to 1
- Operating pressure: PN 350
- Temp range: -20°C to +100°C depending at material selected



RF	G 1/2	CS	
Type	GAS DIN/ISO 228 BSP	NPT ANSI/ASME B1.20.1	Material
RF flow control	G 1/4 G 3/8 G 1/2 G 3/4 G 1	N 1/4 N 3/8 N 1/2 N 3/4 N 1	CS Carbon steel



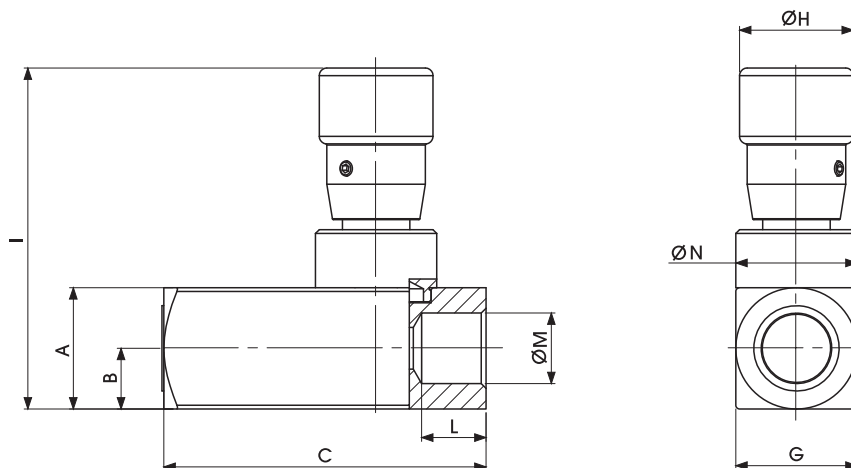

RF DIN/ISO 228 BSP

Standard

CARBON STEEL

TYPE	PN	DN	MAX FLOW L/m	A	B	C	G	ØH	I	L	ØM	ØN	KG	ITEM CODE
RF G 1/4	35 Mpa	6	15	25	12,5	66	25	30	75	15,5	G 1/4	M 20x1	0,41	GF2GGT130110000
RF G 3/8	35 Mpa	10	30	25	12,5	77	25	30	75	15,5	G 3/8	M 20x1	0,42	GF2GGT230110000
RF G 1/2	35 Mpa	13	50	30	15	91	30	33	81	17	G 1/2	M 25x1.5	0,63	GF2GGT330110000
RF G 3/4	35 MPa	20	80	40	20	112,5	40	42	110	21	G 3/4	M 25x1.5	1,52	GF2GGT430110000
RF G 1	35 Mpa	25	150	45	22,5	141	45	42	115	24	G 1	M 35x1.5	2,1	GF2GGT530110000

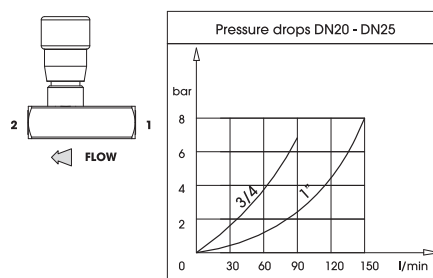
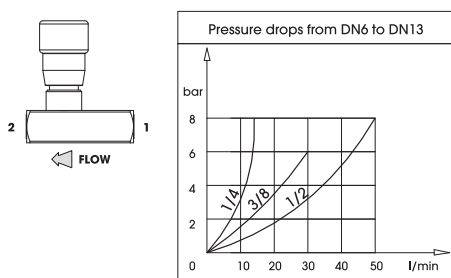

+ RF FLOW CONTROL

www.gemels.it

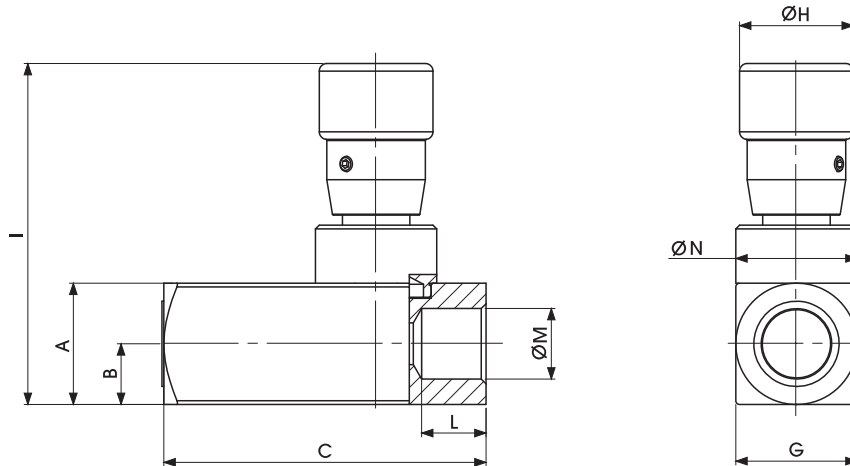

RF ANSI/ASME B1.20.1 NPT

Standard

CARBON STEEL

TYPE	PN	DN	MAX FLOW L/m	A	B	C	G	ØH	I	L	ØM	ØN	KG	ITEM CODE
RF N 1/4	35 Mpa	6	15	25	12,5	66	25	30	75	15,5	N 1/4	M 20x1	0,41	GF2NNT130110000
RF N 3/8	35 Mpa	10	30	25	12,5	77	25	30	75	15,5	N 3/8	M 20x1	0,42	GF2NNT230110000
RF N 1/2	35 Mpa	13	50	30	15	91	30	33	81	17	N 1/2	M 25x1.5	0,63	GF2NNT330110000
RF N 3/4	35 MPa	20	80	40	20	112,5	40	42	110	21	N 3/4	M 25x1.5	1,52	GF2NNT430110000
RF N 1	35 Mpa	25	150	45	22,5	141	45	42	115	24	N 1	M 35x1.5	2,1	GF2NNT530110000

RF

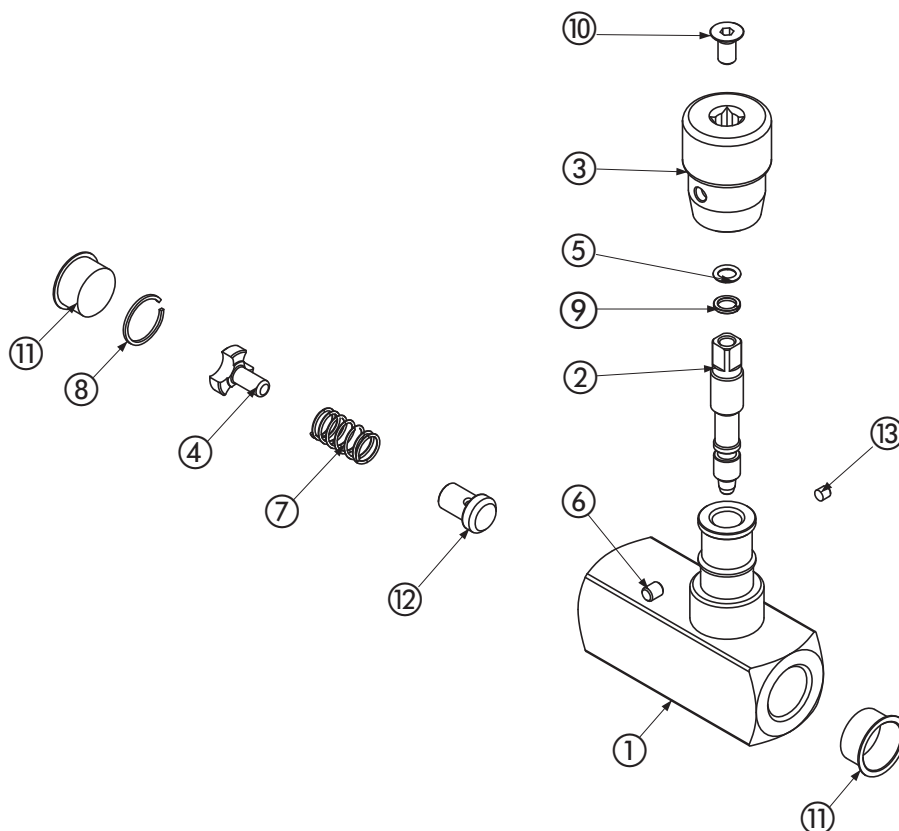

Carbon steel

Pos	Description	Material	Q.tà
1	Body	1,0737	1
2	Stem	1,0503	1
3	Handle	ALLUMINIUM	1
4	Spring ring	X 35 Cr Mo 17	1
5	Stem ring	PTFE	1
6	Spine	1,0737	1
7	Spring	1,0116	1
8	Seeger	X 35 Cr Mo 17	1
9	Stem o-ring	NBR	1
10	Screw	DIN 7991 8.8	1
11	Caps	PVC	2
12	Poppet	1,0737	1
13	Screw	DIN 7991 8.8	1

For further special requests please consult our technical/commercial service

On request

- Special threads
- Pressure class PN 350
- Spring closed: 1BAR - 3BAR - 5BAR - 8BAR

+ BD

FLOW CONTROL
B-DIRECTIONAL

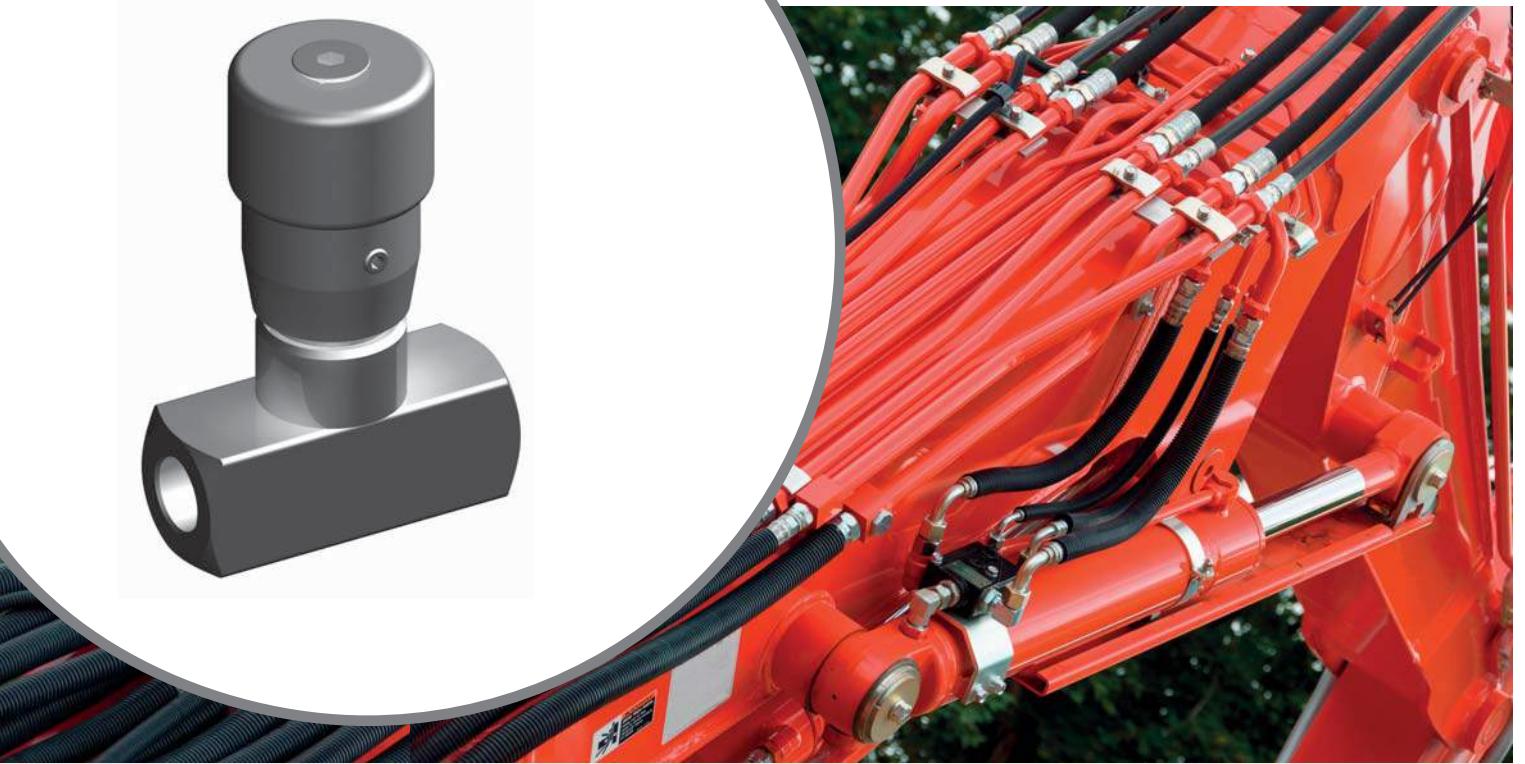
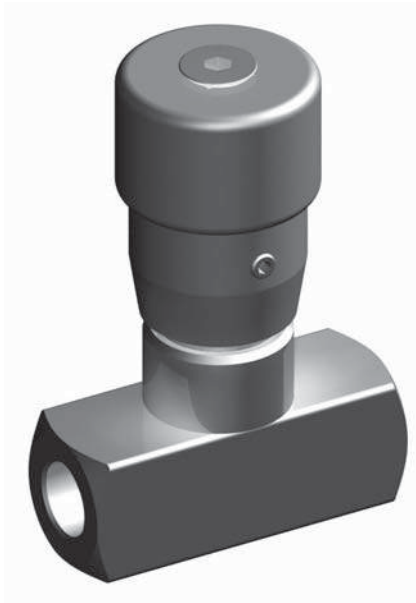

CARBON STEEL

- Type: reduce flow B-directional
- Body: square
- Material: 1,0737/1,4749
- Operating pressure: PN 350
- Temp range: -20°C to +100°C depending on material selected



REDUCE
FLOW
BD

BD	G 1/2		CS
Type	GAS DIN/ISO 228 BSP	NPT ANSI/ASME B1.20.1	Material
BD flow control	G 1/4	N 1/4	CS Carbon steel
	G 3/8	N 3/8	
	G 1/2	N 1/2	
	G 3/4	N 3/4	
	G 1	N 1	



+ BD FLOW CONTROL B-DIRECTIONAL

Specialist in Ball Valves

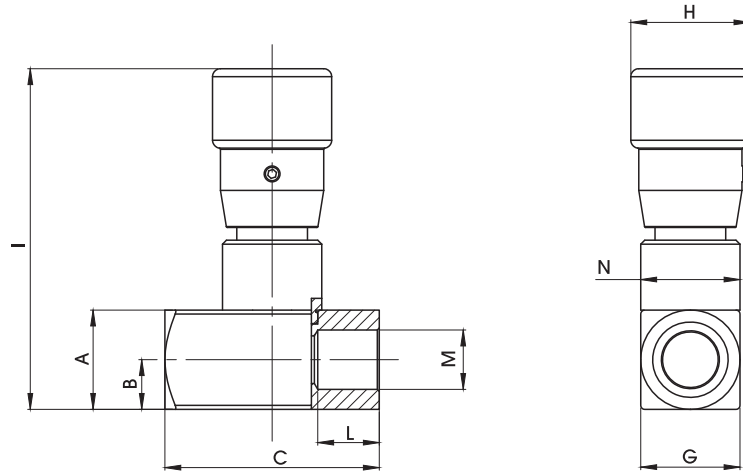

BD DIN/ISO 228 BSP

Standard

CARBON STEEL

TYPE	PN	DN	MAX FLOW L/m	A	B	C	G	ØH	I	L	ØM	ØN	KG	ITEM CODE
BD G 1/4	35 Mpa	6	15	25	12,5	54	25	30	75	15,5	G 1/4	M20X1	0,33	GG2GGT130110000
BD G 3/8	35 Mpa	10	30	25	12,5	54	25	30	75	15,5	G 3/8	M20X1	0,31	GG2GGT230110000
BD G 1/2	35 Mpa	13	50	30	15	64	30	33	81	17	G 1/2	M25X1.5	0,48	GG2GGT330110000
BD G 3/4	35 MPa	20	80	40	20	81	40	42	110	21	G 3/4	M35X1.5	1,13	GG2GGT430110000
BD G 1	35 Mpa	25	150	45	22,5	102	45	42	115	24	G 1	M35X1.5	1,5	GG2GGT530110000

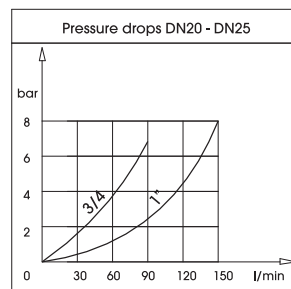
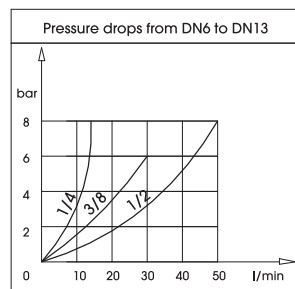
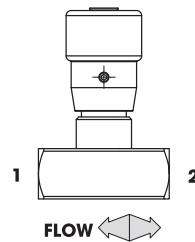
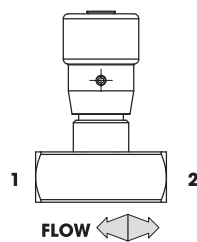

+ BD FLOW CONTROL B-DIRECTIONAL

www.gemels.it

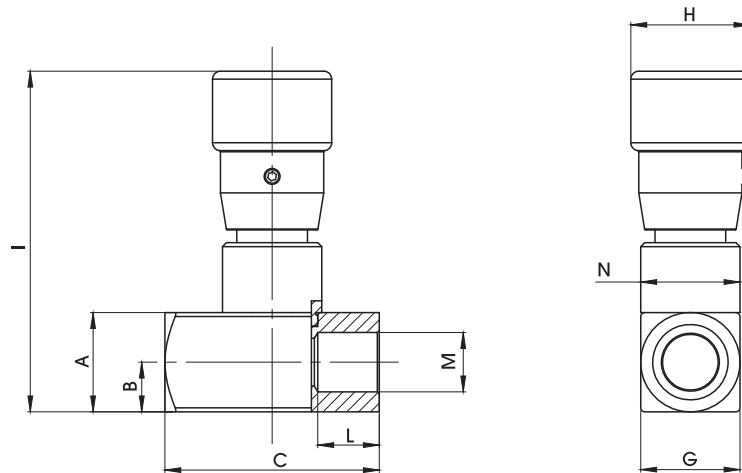

BD ANSI/ASME B1.20.1 NPT

Standard

CARBON STEEL

TYPE	PN	DN	MAX FLOW L/m	A	B	C	G	ØH	I	L	ØM	ØN	KG	ITEM CODE
BD N 1/4	35 Mpa	6	15	25	12,5	54	25	30	75	15,5	N 1/4	M20X1	0,33	GG2NNT130110000
BD N 3/8	35 Mpa	10	30	25	12,5	54	25	30	75	15,5	N 3/8	M20X1	0,31	GG2NNT230110000
BD N 1/2	35 Mpa	13	50	30	15	64	30	33	81	17	N 1/2	M25X1.5	0,48	GG2NNT330110000
BD N 3/4	35 MPa	20	80	40	20	81	40	42	110	21	N 3/4	M35X1.5	1,13	GG2NNT430110000
BD N 1	35 Mpa	25	150	45	22,5	102	45	42	115	24	N 1	M35X1.5	1,5	GG2NNT530110000

BD

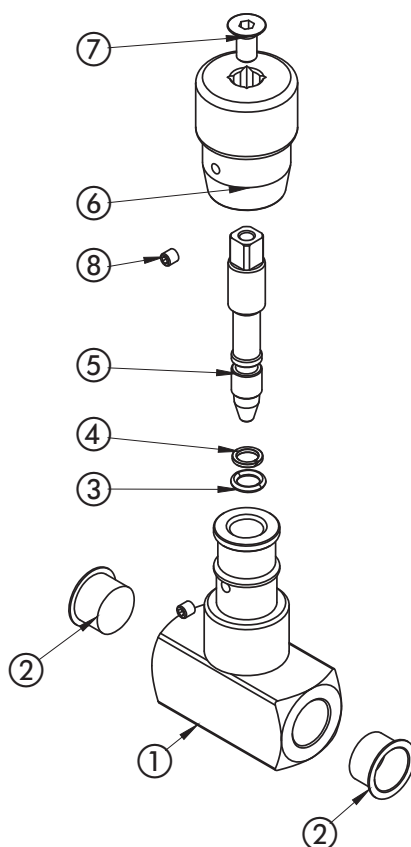

Carbon steel

Pos	Description	Material	Q.tà
1	Body	1,0737	1
2	Caps	PVC	2
3	Stem	1,05	1
4	Stem o-ring	NBR	1
5	Stem ring	PTFE	1
6	Handle	ALLUMINIUM	1
7	Screw	DIN 7991 8.8	1
8	Screw	DIN 7991 8.8	1

*For further special requests please consult
our technical/commercial service*

On request

- Special Threads
- Pressure Class PN 350

+ VU

2-WAY HIGH PRESSURE BALL VALVES



CARBON STEEL

- Type: check valve VU
- Body: exagone
- Material: 1,0737/1,4749
- Ball seats: from 1/4 to 2"
- Operating pressure: up to PN500
- Temp range: -20°C to +100°C



VU	G 1/2	CS	
Type and way of valve	GAS DIN/ISO 228 BSP	NPT ANSI/ASME B1.20.1	Material
VU check valves	G 1/4 G 3/8 G 1/2 G 3/4 G 1 G 1 1/4 G 1 1/2 G 2	N 1/4 N 3/8 N 1/2 N 3/4 N 1 N 1 1/4 N 1 1/2 N 2	CS carbon steel

STAINLESS STEEL

- Type: check valve VU
- Body: exagone
- Material: 1,4404/1,0737 (SS/CS)
- Ball seats: from 1/4 to 2"
- Operating pressure: up to PN500
- Temp range: -30°C to +100°C
different temperatures on request
- All stainless steel on request



VU	G 1/2	SS	
Type and way of valve	GAS DIN/ISO 228 BSP	NPT ANSI/ASME B1.20.1	Material
VU check valves	G 1/4 G 3/8 G 1/2 G 3/4 G 1 G 1 1/4 G 1 1/2 G 2	N 1/4 N 3/8 N 1/2 N 3/4 N 1 N 1 1/4 N 1 1/2 N 2	SS stainless steel CS carbon steel





2-WAY HIGH PRESSURE BALL VALVES

Specialist in Ball Valves

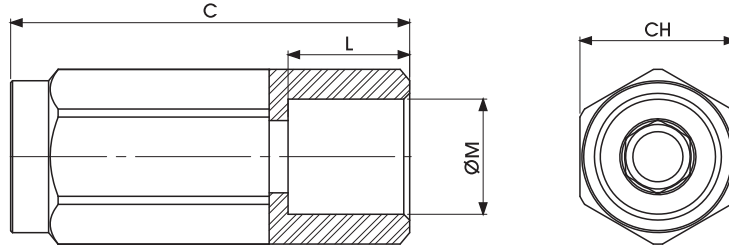

VU DIN ISO 228 BSP GAS

Standard

										CARBON STEEL	STAINLESS STEEL
TYPE	PN	DN	MAX FLOW L/m	CRACKING PRESSURE	C	L	ØM	CH	KG	ITEM CODE	ITEM CODE
VU G 1/4	50 MPa	6	15	0.4/0.7 BAR	62	15.5	G 1/4	19	0,11	GC2GGT150110000	GC2GGT150410000
VU G 3/8	50 MPa	10	30	0.4/0.7 BAR	68	15.5	G 3/8	24	0,2	GC2GGT250110000	GC2GGT250410000
VU G 1/2	50 MPa	13	50	0.4/0.7 BAR	77	17	G 1/2	30	0,35	GC2GGT350110000	GC2GGT350410000
VU G 3/4	40 MPa	20	90	0.4/0.7 BAR	88	21	G 3/4	36	0,53	GC2GGT440110000	GC2GGT440410000
VU G 1	35 MPa	25	150	0.4/0.7 BAR	105	24	G 1	41	0,75	GC2GGT530110000	GC2GGT530410000
VU G 1 1/4	35 MPa	32	200	0.4/0.7 BAR	135	24	G 1 1/4	55	1,81	GC2GGT630110000	GC2GGT630410000
VU G 1 1/2	35 MPa	40	300	0.4/0.7 BAR	145	24	G 1 1/2	60	2,2	GC2GGT730110000	GC2GGT730410000
VU G 2	35 MPa	50	430	0.4/0.7 BAR	175	27	G 2	75	4,17	GC2GGT830110000	GC2GGT830410000

On request trim in stainless steel

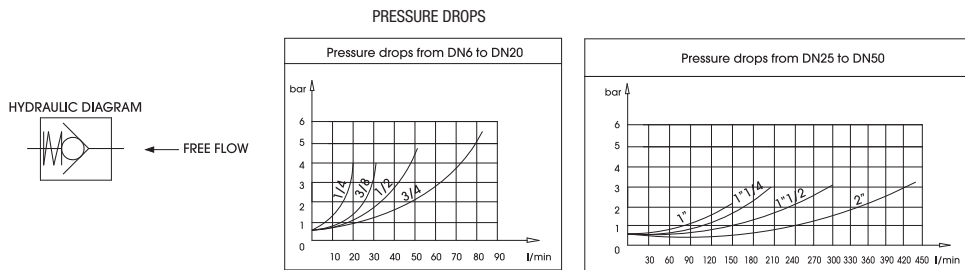

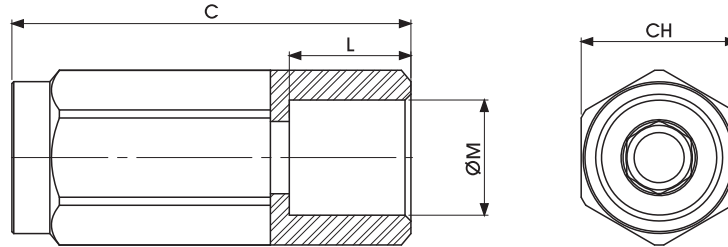

VU ANSI/ASME B1.20.1 NPT

Standard

TYPE	PN	DN	MAX FLOW L/m	CRACKING PRESSURE	C	L	ØM	CH	KG	CARBON STEEL	STAINLESS STEEL
										ITEM CODE	ITEM CODE
VU N 1/4	50 MPa	6	15	0.4/0.7 BAR	62	15.5	N 1/4	19	0,11	GC2NNT150110000	GC2NNT150410000
VU N 3/8	50 MPa	10	30	0.4/0.7 BAR	68	15.5	N 3/8	24	0,2	GC2NNT250110000	GC2NNT250410000
VU N 1/2	50 MPa	13	50	0.4/0.7 BAR	77	17	N 1/2	30	0,35	GC2NNT350110000	GC2NNT350410000
VU N 3/4	40 MPa	20	90	0.4/0.7 BAR	88	21	N 3/4	36	0,53	GC2NNT440110000	GC2NNT440410000
VU N 1	35 MPa	25	150	0.4/0.7 BAR	105	24	N 1	41	0,75	GC2NNT530110000	GC2NNT530410000
VU N 1 1/4	35 MPa	32	200	0.4/0.7 BAR	135	24	N 1 1/4	55	1,81	GC2NNT630110000	GC2NNT630410000
VU N 1 1/2	35 MPa	40	300	0.4/0.7 BAR	145	24	N 1 1/2	60	2,2	GC2NNT730110000	GC2NNT730410000
VU N 2	35 MPa	50	430	0.4/0.7 BAR	175	27	N 2	75	4,17	GC2NNT830110000	GC2NNT830410000

On request trim in stainless steel

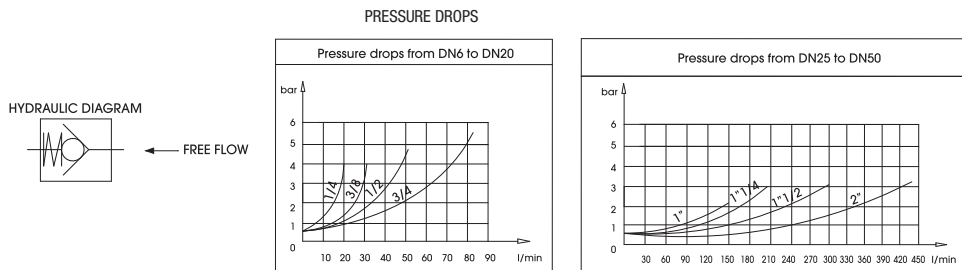



2-WAY HIGH PRESSURE BALL VALVES

Specialist in Ball Valves

2016 - Edition 1

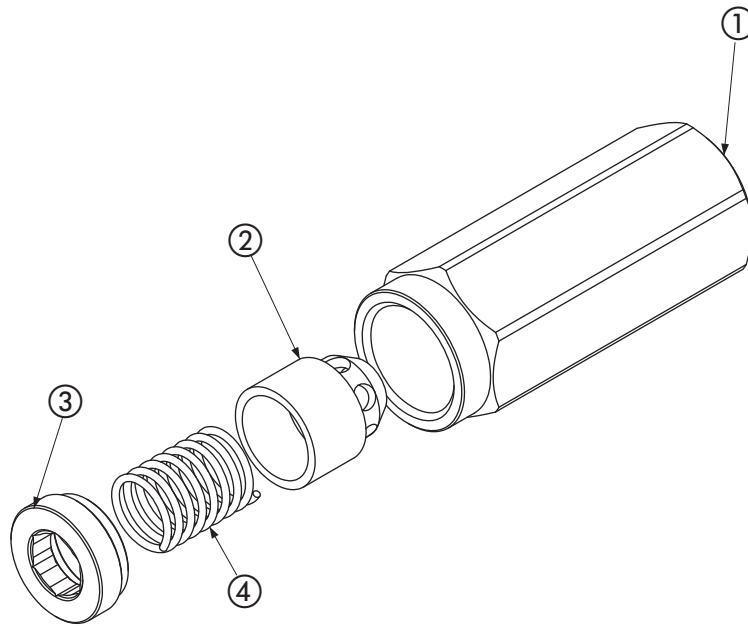

Carbon steel

Pos	Description	Material	Q.tà
1	Body	1,0737	1
2	Poppet	1,4749	1
3	Ring	1,0737	1
4	Spring	1,0116	1

On request

- Special threads
- Pressure class up to PN500
- Spring closed: 1BAR - 3BAR - 5BAR - 8BAR

For further special requests please consult our technical/commercial service

Stainless steel

Pos	Description	Material	Q.tà
1	Body	1,4404	1
2	Poppet	1,4749	1
3	Ring	1,0737	1
4	Spring	1,0116	1

On request

- Special threads
- Pressure class up to PN500
- Spring closed: 1BAR - 3BAR - 5BAR - 8BAR

+ VB VUBA

(HOSE BREAK VALVE)



CARBON STEEL

- Type: hose break valve VB
- Body: exacon
- Material: 1,0737
- Mineral oil: ISO 6743/4/DIN 51524
- Fluid viscosity: 45 to 2000 ssu
- Operating pressure: 300-350 Bar
- Temp range: -20°C to +100°C

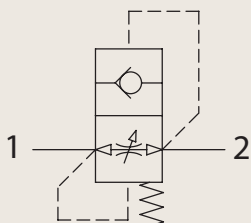

VB	G 3/8	T0,5	F0,5
Type and way of valve VB	Port size G 1/4 G 3/8 G 1/2 G 3/4 G 1	Setting 0,25 --> 4,25	Throttling hole 0,5 --> 3,0

VBF Female insert
VBM Male insert

TYPE	F (Throttling hole*)	
	Ø MIN (mm)	Ø MAX (mm)
VB G 1/4	0,50	1,00
VB G 3/8	0,50	1,25
VB G 1/2	0,50	1,50
VB G 3/4	0,50	2,50
VB G 1	0,50	3,00

* omit if not requested



+ VB VUBA (HOSE BREAK VALVE)

Specialist in Ball Valves

COMPONENTS

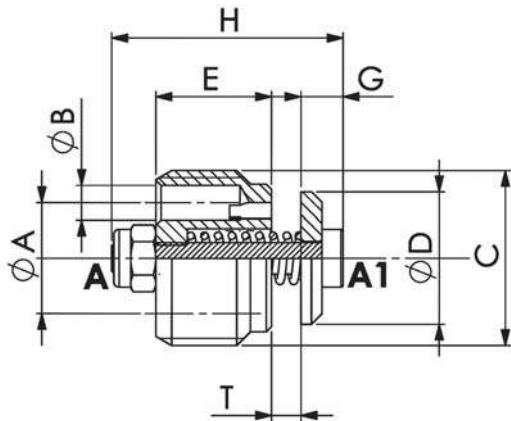

VB VALVE

Standard

TYPE	FLOW min-max l/min	A	B	C	D	E	G	H	KG	ITEM CODE
VB G 3/8	16-50	11	3,5	3/8	12,5	11	5,0	23	0,0125	G540103A01AAPAA
VB G 1/2	25-80	13	4,5	1/2	15,0	13	6,0	29	0,0235	G540104A01AAPAA
VB G 3/4	50-150	16	6,0	3/4	18,5	18	6,0	34	0,0460	G540105A01AAPAA
VB G 1	70-200	20	7,0	1	23,0	21	7,5	40	0,0945	G540106A01AAPAA

VBF Female housing

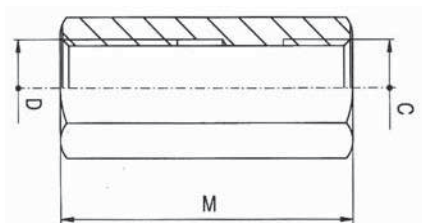

TYPE	CS	C-D	M	KG	Q (L/1')	ITEM CODE
VBF G 1/4	1/4	G 1/4	48	0,01	28	C01AA03583A010Z
VBF G 3/8	3/8	G 3/8	52	0,01	50	C01AA03584A010Z
VBF G 1/2	1/2	G 1/2	60	0,02	85	C01AA03585A010Z
VBF G 3/4	3/4	G 3/4	72	0,05	150	C01AA03586A010Z
VBF G 1	1	G 1	85	0,09	180	C01AA03587A010Z

VBM Male housing

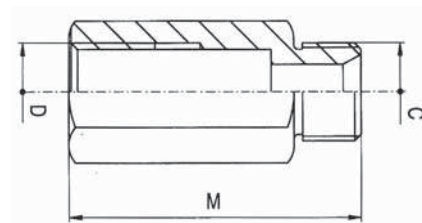

TYPE	CS	C-D	M	KG	Q (L/1')	ITEM CODE
VBM G 1/4	1/4	G 1/4	48	0,01	28	C01AA03578A010Z
VBM G 3/8	3/8	G 3/8	58	0,01	50	C01AA03579A010Z
VBM G 1/2	1/2	G 1/2	65	0,02	85	C01AA03580A010Z
VBM G 3/4	3/4	G 3/4	78	0,05	150	C01AA03581A010Z
VBM G 1	1	G 1	85	0,09	180	C01AA03582A010Z

For actuator moved by directional control valve, the reaction flow has to be calculated multiply the nominal flow by 1.5 and by 2 for actuator moved by solenoid operated directional control valve. It is normal to set the reaction flow 1,5 times the rate flow of the system. If not required, the setting of "T" will be supplied at the maximum value.

Warning:
the setting values indicated in this diagram are indicative, for any setting value of "T", the reaction flow can change by $\pm 10\%$ and beyond based on the features of the equipment in which they are installed.

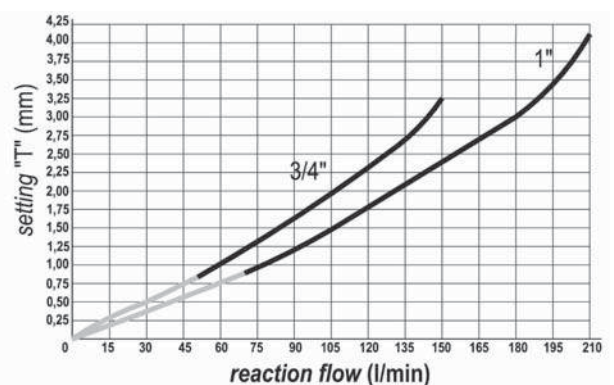
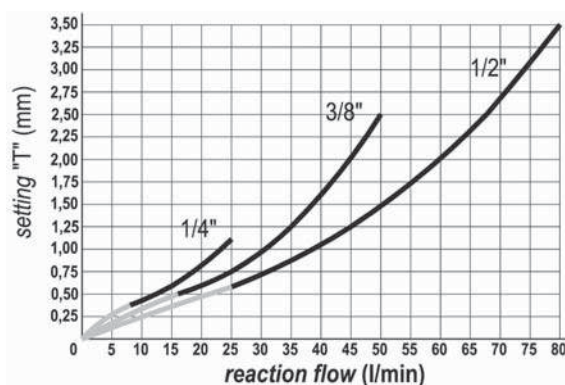

"The company reserves the right to operate dimensional changes without prior notice".

+ VB VUBA (HOSE BREAK VALVE)

www.gemels.it

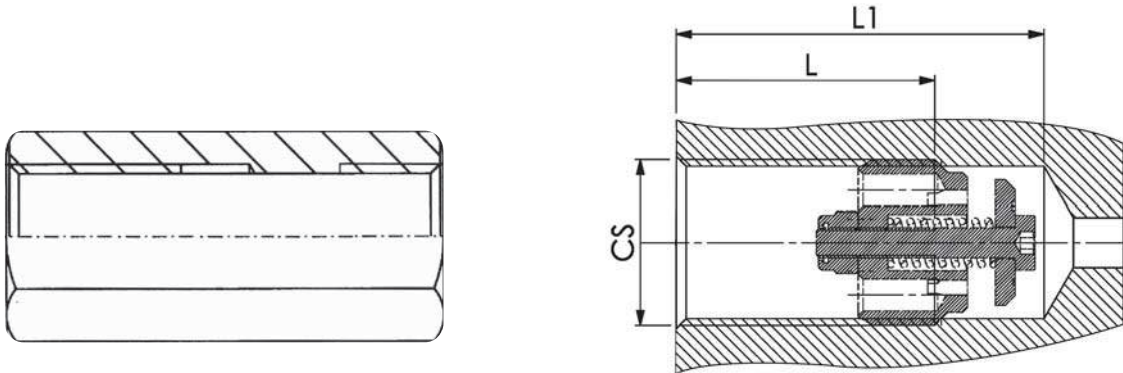

Applications:

Screw in the valve connecting 1 to the pressure flow and 2 to the actuator.
The use together with flow control valve is recommended.

VB + VBF Assembled (Female-Female)

TYPE	FLOW min-max	MAX PRESSURE	T	CAVITY			ITEM CODE
	l/min			BAR	CS	L	
VB G 1/4	8-25	350	see diagram	1/4	24,2	35,2	G480202A0100PAA
VB G 3/8	16-50			3/8	26,2	37,1	G480203A0100PAA
VB G 1/2	25-80			1/2	30,3	45,2	G480204A0100PAA
VB G 3/4	50-150			3/4	38,1	54,2	G480205A0100PAA
VB G 1	70-200			1	46,2	66,1	G480206A0100PAA

VB + VBM Assembled (Male-Female)

TYPE	FLOW min-max	MAX PRESSURE	T	CAVITY			ITEM CODE
	l/min			BAR	CS	L	
VB G 1/4	8-25	350	see diagram	1/4	24,2	35,2	G580302A0100PAA
VB G 3/8	16-50			3/8	26,2	37,1	G580303A0100PAA
VB G 1/2	25-80			1/2	30,3	45,2	G580304A0100PAA
VB G 3/4	50-150			3/4	38,1	54,2	G580305A0100PAA
VB G 1	70-200			1	46,2	66,1	G580306A0100PAA



OIL&GAS

GM1 - GM - GN - SBF - SBT



TECH
MATERIAL

KITS
LOCKING - HANDLES
FLANGE - LIMIT SWITCHES
ACTUATORS - SEALS KITS

OIL&GAS
GM1-GM - GN
SBF - SBT

OTHER
GHP - GPS - RF
BD - VU - VUJBA

GR
GRC - GRS

GPK
GPK2 - GPK3

G3K-4K
G3K - G4K

GV
GV2 - GV3

GB
GB2 - GB3 - GBF
GBS - GBC

GE
GEM - GE1 - GE2 - GE3
GE5 - GE3K - GEF
GES - GEC - GEV

+ GM1

2-WAY HIGH PRESSURE BALL VALVES



CARBON STEEL

- Type: ball valve GM1 2way
- Body: round
- Material: 1,0570/1,4404
- Ball seats: from DN6 up to DN25
- O-Rings: NBR, FKM, EPDM, MVQ
- Operating pressure: 50 Bar to 500 Bar S800 to S6000 PN depending on valve size and seal materials selected
- Fire safe BS 6755
- Antistatic device
- Temp range: -46°C to +250°C depending on seal material selected

GM1

Type and way of valve
GM1 2-way

G 1/2

GAS	NPT
DIN/ISO	ANSI/ASME
228 BSP	B1.20.1
G 1/4	N 1/4
G 3/8	N 3/8
G 1/2	N 1/2
G 3/4	N 3/4
G 1	N 1

DN13 LF2

Nominal dimension	Body and adapter material
DN6	
DN10	LF2 1,0570
DN13	
DN20	
DN25	

316L POM B

Stem and ball material	Ball seat material	Adapter and stem seal material
316L 1,4404	A POM	B NBR
	D PEEK	E FKM
	C PTFE	F EPDM
		L MVQ

STAINLESS STEEL

- Type: ball valve GM1 2way
- Body: round
- Material: 1,4404
- Ball seats: from DN6 up to DN25
- O-Rings: NBR, FKM, EPDM, MVQ
- Operating pressure: 50 Bar to 500 Bar S800 to S6000 PN depending on valve size and seal materials selected
- Fire safe BS 6755
- Antistatic device
- Temp range: -30°C to +100°C different temperatures on request

GM1

Type and way of valve
GM1 2-way

G 1/2

GAS	NPT
DIN/ISO	ANSI/ASME
228 BSP	B1.20.1
G 1/4	N 1/4
G 3/8	N 3/8
G 1/2	N 1/2
G 3/4	N 3/4
G 1	N 1

DN13 316L 316L POM B

Nominal dimension	Body and adapter material	Stem and ball material	Ball seat material	Adapter and stem seal material
DN6			A POM	B NBR
DN10	316L 1,4404	316L 1,4404	D PEEK	E FKM
DN13			C PTFE	F EPDM
DN20				L MVQ
DN25				

GM1

+ GM1 2-WAY HIGH PRESSURE BALL VALVES

Specialist in Ball Valves

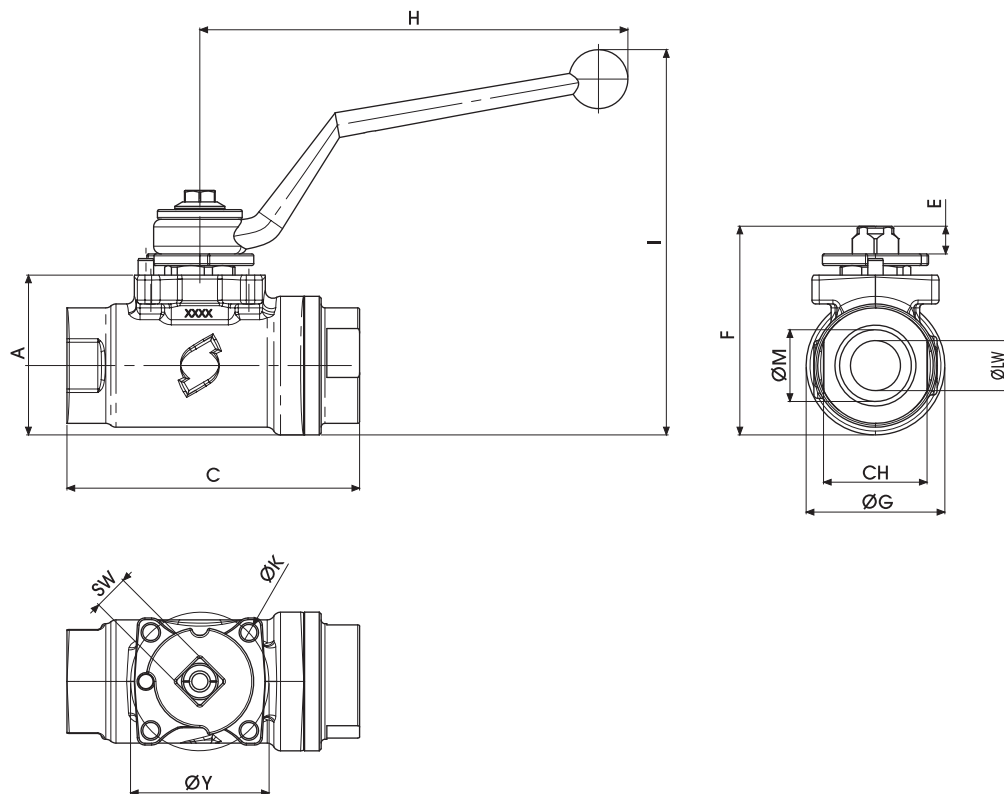

GM1 DIN/ISO 228 BSP

Standard

TYPE	DN	A	C	E	F	ØG	H	I	L	ØK	ØY	ØM	CH	SW	ØLW	KG
GM1 G 1/4	6	37,5	72	8	53	31	102,5	94	15,5	M5	36	G 1/4	22	9	6	0,41
GM1 G 3/8	10	37,5	72	8	53	31	102,5	94	15,5	M5	36	G 3/8	22	9	10	0,40
GM1 G 1/2	13	42	81	8	57	36	102,5	100	17	M5	36	G 1/2	27	9	13	0,50
GM1 G 3/4	20	60	98	14	83	49	180	115	21	M6	50	G 3/4	35	14	20	1,45
GM1 G 1	25	68	106	14	91	59	180	123	24	M6	50	G 1	42	14	25	1,98

+ GM1

2-WAY HIGH PRESSURE BALL VALVES

www.gemels.it

(POM seal)

GM1 DIN/ISO 228 PN

DN	PN	CARBON STEEL		STAINLESS STEEL	
		ITEM CODE	ITEM CODE	ITEM CODE	ITEM CODE
6	500	GM1GGT15024A000	GM1GGT15044A000	GM1GGT15024A000	GM1GGT15044A000
10	500	GM1GGT25024A000	GM1GGT25044A000	GM1GGT25024A000	GM1GGT25044A000
13	500	GM1GGT35024A000	GM1GGT35044A000	GM1GGT35024A000	GM1GGT35044A000
20	400	GM1GGT44024A000	GM1GGT44044A000	GM1GGT44024A000	GM1GGT44044A000
25	350	GM1GGT53024A000	GM1GGT53044A000	GM1GGT53024A000	GM1GGT53044A000

(POM seal)

GM1 DIN/ISO 228 S3000

DN	PN	CARBON STEEL		STAINLESS STEEL	
		ITEM CODE	ITEM CODE	ITEM CODE	ITEM CODE
6	S3000	GM1GGT1F024A000	GM1GGT1F044A000	GM1GGT1F024A000	GM1GGT1F044A000
10	S3000	GM1GGT2F024A000	GM1GGT2F044A000	GM1GGT2F024A000	GM1GGT2F044A000
13	S3000	GM1GGT3F024A000	GM1GGT3F044A000	GM1GGT3F024A000	GM1GGT3F044A000
20	S3000	GM1GGT4F024A000	GM1GGT4F044A000	GM1GGT4F024A000	GM1GGT4F044A000
25	S3000	GM1GGT5F024A000	GM1GGT5F044A000	GM1GGT5F024A000	GM1GGT5F044A000

(POM seal)

GM1 DIN/ISO 228 S6000

DN	PN	CARBON STEEL		STAINLESS STEEL	
		ITEM CODE	ITEM CODE	ITEM CODE	ITEM CODE
6	S6000	GM1GGT1G024A000	GM1GGT1G044A000	GM1GGT1G024A000	GM1GGT1G044A000
10	S6000	GM1GGT2G024A000	GM1GGT2G044A000	GM1GGT2G024A000	GM1GGT2G044A000
13	S6000	GM1GGT3G024A000	GM1GGT3G044A000	GM1GGT3G024A000	GM1GGT3G044A000
20	S6000	GM1GGT4G024A000	GM1GGT4G044A000	GM1GGT4G024A000	GM1GGT4G044A000
25	S6000	GM1GGT5G024A000	GM1GGT5G044A000	GM1GGT5G024A000	GM1GGT5G044A000

(PEEK seal)

GM1 DIN/ISO 228 PN

DN	PN	CARBON STEEL		STAINLESS STEEL	
		ITEM CODE	ITEM CODE	ITEM CODE	ITEM CODE
6	500	GM1GGT15024P000	GM1GGT15044P000	GM1GGT15024P000	GM1GGT15044P000
10	500	GM1GGT25024P000	GM1GGT25044P000	GM1GGT25024P000	GM1GGT25044P000
13	500	GM1GGT35024P000	GM1GGT35044P000	GM1GGT35024P000	GM1GGT35044P000
20	400	GM1GGT44024P000	GM1GGT44044P000	GM1GGT44024P000	GM1GGT44044P000
25	350	GM1GGT53024P000	GM1GGT53044P000	GM1GGT53024P000	GM1GGT53044P000

(PEEK seal)

GM1 DIN/ISO 228 S3000

DN	PN	CARBON STEEL		STAINLESS STEEL	
		ITEM CODE	ITEM CODE	ITEM CODE	ITEM CODE
6	S3000	GM1GGT1F024P000	GM1GGT1F044P000	GM1GGT1F024P000	GM1GGT1F044P000
10	S3000	GM1GGT2F024P000	GM1GGT2F044P000	GM1GGT2F024P000	GM1GGT2F044P000
13	S3000	GM1GGT3F024P000	GM1GGT3F044P000	GM1GGT3F024P000	GM1GGT3F044P000
20	S3000	GM1GGT4F024P000	GM1GGT4F044P000	GM1GGT4F024P000	GM1GGT4F044P000
25	S3000	GM1GGT5F024P000	GM1GGT5F044P000	GM1GGT5F024P000	GM1GGT5F044P000

(PEEK seal)

GM1 DIN/ISO 228 S6000

DN	PN	CARBON STEEL		STAINLESS STEEL	
		ITEM CODE	ITEM CODE	ITEM CODE	ITEM CODE
6	S6000	GM1GGT1G024P000	GM1GGT1G044P000	GM1GGT1G024P000	GM1GGT1G044P000
10	S6000	GM1GGT2G024P000	GM1GGT2G044P000	GM1GGT2G024P000	GM1GGT2G044P000
13	S6000	GM1GGT3G024P000	GM1GGT3G044P000	GM1GGT3G024P000	GM1GGT3G044P000
20	S6000	GM1GGT4G024P000	GM1GGT4G044P000	GM1GGT4G024P000	GM1GGT4G044P000
25	S6000	GM1GGT5G024P000	GM1GGT5G044P000	GM1GGT5G024P000	GM1GGT5G044P000

(PTFE seal)

GM1 DIN/ISO 228 S800

DN	PN	CARBON STEEL		STAINLESS STEEL	
		ITEM CODE	ITEM CODE	ITEM CODE	ITEM CODE
6	S800	GM1GGT1A024F000	GM1GGT1A044F000	GM1GGT1A024F000	GM1GGT1A044F000
10	S800	GM1GGT2A024F000	GM1GGT2A044F000	GM1GGT2A024F000	GM1GGT2A044F000
13	S800	GM1GGT3A024F000	GM1GGT3A044F000	GM1GGT3A024F000	GM1GGT3A044F000
20	S800	GM1GGT4A024F000	GM1GGT4A044F000	GM1GGT4A024F000	GM1GGT4A044F000
25	S800	GM1GGT5A024F000	GM1GGT5A044F000	GM1GGT5A024F000	GM1GGT5A044F000

(PTFE seal)

GM1 DIN/ISO 228 S3000

DN	PN	CARBON STEEL		STAINLESS STEEL	
		ITEM CODE	ITEM CODE	ITEM CODE	ITEM CODE
6	S3000	GM1GGT1F024F000	GM1GGT1F044F000	GM1GGT1F024F000	GM1GGT1F044F000
10	S3000	GM1GGT2F024F000	GM1GGT2F044F000	GM1GGT2F024F000	GM1GGT2F044F000
13	S3000	GM1GGT3F024F000	GM1GGT3F044F000	GM1GGT3F024F000	GM1GGT3F044F000
20	S3000	GM1GGT4F024F000	GM1GGT4F044F000	GM1GGT4F024F000	GM1GGT4F044F000
25	S3000	GM1GGT5F024F000	GM1GGT5F044F000	GM1GGT5F024F000	GM1GGT5F044F000

GM1

+ GM1 2-WAY HIGH PRESSURE BALL VALVES

Specialist in Ball Valves

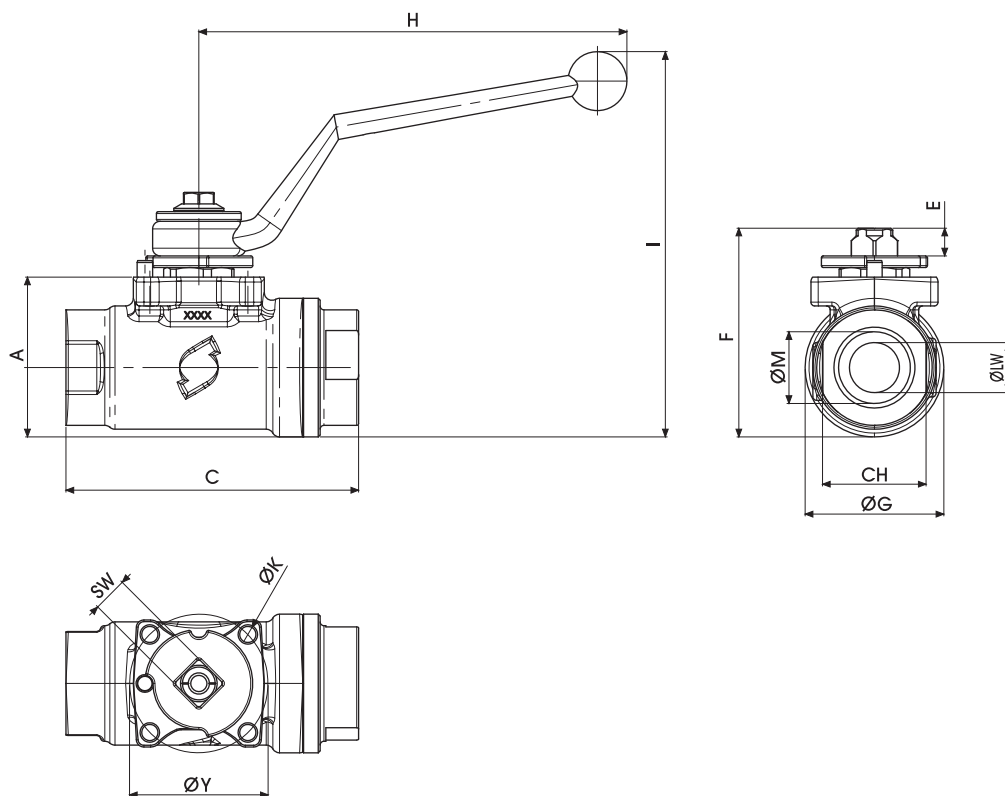

GM1 ANSI/ASME B1.20.1 NPT

Standard

TYPE	DN	A	C	E	F	ØG	H	I	L	ØK	ØY	ØM	CH	SW	ØLW	KG
GM1 N 1/4	6	37,5	72	8	53	31	102,5	94	15,5	M5	36	N 1/4	22	9	6	0,41
GM1 N 3/8	10	37,5	72	8	53	31	102,5	94	15,5	M5	36	N 3/8	22	9	10	0,40
GM1 N 1/2	13	42	81	8	57	36	102,5	100	17	M5	36	N 1/2	27	9	13	0,50
GM1 N 3/4	20	60	98	14	83	49	180	115	21	M6	50	N 3/4	35	14	20	1,45
GM1 N 1	25	68	106	14	91	59	180	123	24	M6	50	N 1	42	14	25	1,98

+ GM1

2-WAY HIGH PRESSURE BALL VALVES

www.gemels.it

(POM seal) GM1 ANSI/ASME B1.20.1 NPT PN

DN	PN	CARBON STEEL		STAINLESS STEEL	
		ITEM CODE	ITEM CODE	ITEM CODE	ITEM CODE
6	500	GM1NNT15024A000	GM1NNT15044A000	GM1NNT15044A000	GM1NNT15044A000
10	500	GM1NNT25024A000	GM1NNT25044A000	GM1NNT25044A000	GM1NNT25044A000
13	500	GM1NNT35024A000	GM1NNT35044A000	GM1NNT35044A000	GM1NNT35044A000
20	400	GM1NNT44024A000	GM1NNT44044A000	GM1NNT44044A000	GM1NNT44044A000
25	350	GM1NNT53024A000	GM1NNT53044A000	GM1NNT53044A000	GM1NNT53044A000

(POM seal) GM1 ANSI/ASME B1.20.1 NPT S3000

DN	PN	CARBON STEEL		STAINLESS STEEL	
		ITEM CODE	ITEM CODE	ITEM CODE	ITEM CODE
6	S3000	GM1NNT1F024A000	GM1NNT1F044A000	GM1NNT1F044A000	GM1NNT1F044A000
10	S3000	GM1NNT2F024A000	GM1NNT2F044A000	GM1NNT2F044A000	GM1NNT2F044A000
13	S3000	GM1NNT3F024A000	GM1NNT3F044A000	GM1NNT3F044A000	GM1NNT3F044A000
20	S3000	GM1NNT4F024A000	GM1NNT4F044A000	GM1NNT4F044A000	GM1NNT4F044A000
25	S3000	GM1NNT5F024A000	GM1NNT5F044A000	GM1NNT5F044A000	GM1NNT5F044A000

(POM seal) GM1 ANSI/ASME B1.20.1 NPT S6000

DN	PN	CARBON STEEL		STAINLESS STEEL	
		ITEM CODE	ITEM CODE	ITEM CODE	ITEM CODE
6	S6000	GM1NNT1G024A000	GM1NNT1G044A000	GM1NNT1G044A000	GM1NNT1G044A000
10	S6000	GM1NNT2G024A000	GM1NNT2G044A000	GM1NNT2G044A000	GM1NNT2G044A000
13	S6000	GM1NNT3G024A000	GM1NNT3G044A000	GM1NNT3G044A000	GM1NNT3G044A000
20	S6000	GM1NNT4G024A000	GM1NNT4G044A000	GM1NNT4G044A000	GM1NNT4G044A000
25	S6000	GM1NNT5G024A000	GM1NNT5G044A000	GM1NNT5G044A000	GM1NNT5G044A000

(PEEK seal) GM1 ANSI/ASME B1.20.1 NPT PN

DN	PN	CARBON STEEL		STAINLESS STEEL	
		ITEM CODE	ITEM CODE	ITEM CODE	ITEM CODE
6	500	GM1NNT15024P000	GM1NNT15044P000	GM1NNT15044P000	GM1NNT15044P000
10	500	GM1NNT25024P000	GM1NNT25044P000	GM1NNT25044P000	GM1NNT25044P000
13	500	GM1NNT35024P000	GM1NNT35044P000	GM1NNT35044P000	GM1NNT35044P000
20	400	GM1NNT44024P000	GM1NNT44044P000	GM1NNT44044P000	GM1NNT44044P000
25	350	GM1NNT53024P000	GM1NNT53044P000	GM1NNT53044P000	GM1NNT53044P000

(PEEK seal) GM1 ANSI/ASME B1.20.1 NPT S3000

DN	PN	CARBON STEEL		STAINLESS STEEL	
		ITEM CODE	ITEM CODE	ITEM CODE	ITEM CODE
6	S3000	GM1NNT1F024P000	GM1NNT1F044P000	GM1NNT1F044P000	GM1NNT1F044P000
10	S3000	GM1NNT2F024P000	GM1NNT2F044P000	GM1NNT2F044P000	GM1NNT2F044P000
13	S3000	GM1NNT3F024P000	GM1NNT3F044P000	GM1NNT3F044P000	GM1NNT3F044P000
20	S3000	GM1NNT4F024P000	GM1NNT4F044P000	GM1NNT4F044P000	GM1NNT4F044P000
25	S3000	GM1NNT5F024P000	GM1NNT5F044P000	GM1NNT5F044P000	GM1NNT5F044P000

(PEEK seal) GM1 ANSI/ASME B1.20.1 NPT S6000

DN	PN	CARBON STEEL		STAINLESS STEEL	
		ITEM CODE	ITEM CODE	ITEM CODE	ITEM CODE
6	S6000	GM1NNT1G024P000	GM1NNT1G044P000	GM1NNT1G044P000	GM1NNT1G044P000
10	S6000	GM1NNT2G024P000	GM1NNT2G044P000	GM1NNT2G044P000	GM1NNT2G044P000
13	S6000	GM1NNT3G024P000	GM1NNT3G044P000	GM1NNT3G044P000	GM1NNT3G044P000
20	S6000	GM1NNT4G024P000	GM1NNT4G044P000	GM1NNT4G044P000	GM1NNT4G044P000
25	S6000	GM1NNT5G024P000	GM1NNT5G044P000	GM1NNT5G044P000	GM1NNT5G044P000

(PTFE seal) GM1 ANSI/ASME B1.20.1 NPT S800

DN	PN	CARBON STEEL		STAINLESS STEEL	
		ITEM CODE	ITEM CODE	ITEM CODE	ITEM CODE
6	S800	GM1NNT1A024F000	GM1NNT1A044F000	GM1NNT1A044F000	GM1NNT1A044F000
10	S800	GM1NNT2A024F000	GM1NNT2A044F000	GM1NNT2A044F000	GM1NNT2A044F000
13	S800	GM1NNT3A024F000	GM1NNT3A044F000	GM1NNT3A044F000	GM1NNT3A044F000
20	S800	GM1NNT4A024F000	GM1NNT4A044F000	GM1NNT4A044F000	GM1NNT4A044F000
25	S800	GM1NNT5A024F000	GM1NNT5A044F000	GM1NNT5A044F000	GM1NNT5A044F000

(PTFE seal) GM1 ANSI/ASME B1.20.1 NPT S3000

DN	PN	CARBON STEEL		STAINLESS STEEL	
		ITEM CODE	ITEM CODE	ITEM CODE	ITEM CODE
6	S3000	GM1NNT1F024F000	GM1NNT1F044F000	GM1NNT1F044F000	GM1NNT1F044F000
10	S3000	GM1NNT2F024F000	GM1NNT2F044F000	GM1NNT2F044F000	GM1NNT2F044F000
13	S3000	GM1NNT3F024F000	GM1NNT3F044F000	GM1NNT3F044F000	GM1NNT3F044F000
20	S3000	GM1NNT4F024F000	GM1NNT4F044F000	GM1NNT4F044F000	GM1NNT4F044F000
25	S3000	GM1NNT5F024F000	GM1NNT5F044F000	GM1NNT5F044F000	GM1NNT5F044F000



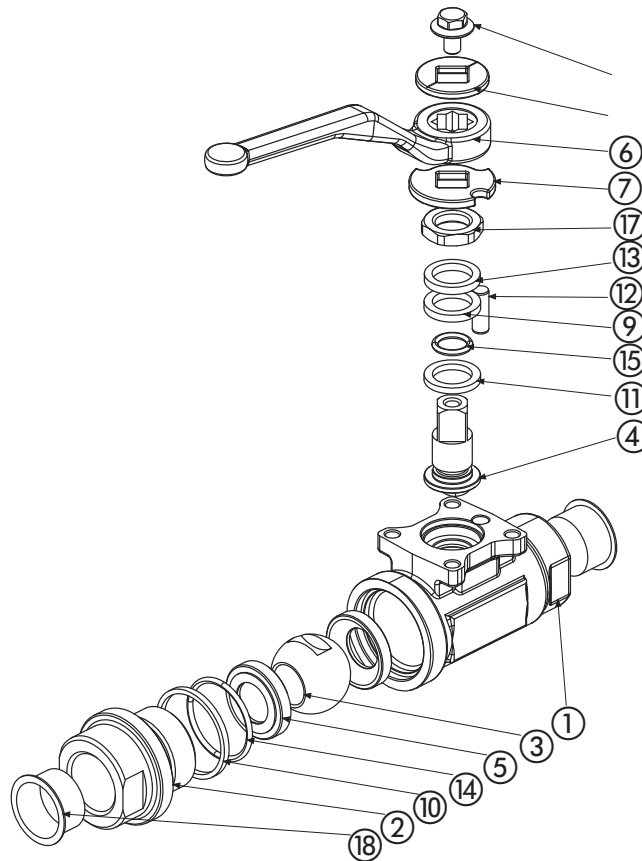

Carbon steel

Pos	Description	Material	Q.tà
1	Body	1,0570	1
2	Adapter	1,0570	2
3	Ball	1,4404	1
4	Stem	1,4404	1
5	Ball Seat	PTFE	2
6	Handle	1,0116	1
7	Washer	1,4301	1
8	Washer	1,4301	1
9	Body ring	GRAPHITE	1
10	Adapter ring	GRAPHITE	2
11	Stem ring	PTFE	2
12	Spine	1,4301	1
13	Press ring	1,4301	1
14	Adapter o-ring	NBR	2
15	Stem o-ring	NBR	1
16	Screw	DIN6921 A2	1
17	Nut	1,4301	1
18	Caps	PVC	2

- On request**
- Reduced bore
 - O-Ring in FKM, EPDM, HNBR, KALREZ
 - Seals in PTFE, PEEK, PA612, GEMPTFE, METAL TO METAL
 - Special threads
 - Pressure class up to PN500 or 6000 Psi
 - Locking device

For further special requests please consult our technical/commercial service

Stainless steel

Pos	Description	Material	Q.tà
1	Body	1,4404	1
2	Adapter	1,4404	2
3	Ball	1,4404	1
4	Stem	1,4404	1
5	Ball Seat	PTFE	2
6	Handle	1,0116	1
7	Washer	1,4301	1
8	Washer	1,4301	1
9	Body ring	GRAPHITE	1
10	Adapter ring	GRAPHITE	2
11	Stem ring	PTFE	2
12	Spine	1,4301	1
13	Press ring	1,4301	1
14	Adapter o-ring	NBR	2
15	Stem o-ring	NBR	1
16	Screw	DIN6921 A2	1
17	Nut	1,4301	1
18	Caps	PVC	2

- On request**
- Reduced bore
 - O-Ring in FKM, EPDM, HNBR, KALREZ
 - Seals in PTFE, PEEK, PA612, GEMPTFE, METAL TO METAL
 - Special threads
 - Pressure class up to PN500 or 6000 Psi
 - Locking device

+ GM

2-WAY HIGH PRESSURE BALL VALVES



CARBON STEEL

- Type: ball valve GM 2way
- Body: round
- Material: 1,0570/1,4404
- Ball seats: from DN6 up to DN100
- O-Rings: NBR, FKM, EPDM, MVQ
- Operating pressure: 50 Bar to 500 Bar S800 to S3000 PN depending on valve size and seal materials selected
- Fire safe BS 6755
- Antistatic device
- Temp range: -46°C to +250°C depending on seal material selected

GM

G 1/2

DN13

LF2

316L

POM

B

Type and way of valve	GAS DIN/ISO 228 BSP	NPT ANSI/ASME B1.20.1	SW	SW EXTRALONG	PE	Nominal dimension	Body and adapter material	Stem and ball material	Ball seat material	Adapter and stem seal material
GM 2-way	G 1/4	N 1/4	SW 1/4	SWXT 1/4	PE 1/4	DN6			A POM	B NBR
	G 3/8	N 3/8	SW 3/8	SWXT 3/8	PE 3/8	DN10	LF2 1,0570	316L 1,4404	D PEEK	E FKM
	G 1/2	N 1/2	SW 1/2	SWXT 1/2	PE 1/2	DN13			C PTFE	F EPDM
	G 3/4	N 3/4	SW 3/4	SWXT 3/4	PE 3/4	DN20				L MVQ
	G 1	N 1	SW 1	SWXT 1	PE 1	DN25				
	G 1 1/4	N 1 1/4	SW 1 1/4	SWXT 1 1/4	PE 1 1/4	DN32				
	G 1 1/2	N 1 1/2	SW 1 1/2	SWXT 1 1/2	PE 1 1/2	DN40				
	G 2	N 2	SW 2	SWXT 2	PE 2	DN50				
	G 2 1/2	N 2 1/2	SW 2 1/2			DN65				
	G 3	N 3	SW 3			DN80				
	G 4	N 4	SW 4			DN100				

STAINLESS STEEL

- Type: ball valve GM 2way
- Body: round
- Material: 1,4404
- Ball seats: from DN6 up to DN100
- O-Rings: NBR, FKM, EPDM, MVQ
- Operating pressure: 50 Bar to 500 Bar S800 to S3000 PN depending on valve size and seal materials selected
- Fire safe BS 6755
- Antistatic device
- Temp range: -30°C to +100°C different temperatures on request

GM

G 1/2

DN13

316L

316L

POM

B

Type and way of valve	GAS DIN/ISO 228 BSP	NPT ANSI/ASME B1.20.1	SW	SW EXTRALONG	PE	Nominal dimension	Body and adapter material	Stem and ball material	Ball seat material	Adapter and stem seal material
GM 2-way	G 1/4	N 1/4	SW 1/4	SWXT 1/4	PE 1/4	DN6			A POM	B NBR
	G 3/8	N 3/8	SW 3/8	SWXT 3/8	PE 3/8	DN10	316L 1,4404	316L 1,4404	D PEEK	E FKM
	G 1/2	N 1/2	SW 1/2	SWXT 1/2	PE 1/2	DN13			C PTFE	F EPDM
	G 3/4	N 3/4	SW 3/4	SWXT 3/4	PE 3/4	DN20				L MVQ
	G 1	N 1	SW 1	SWXT 1	PE 1	DN25				
	G 1 1/4	N 1 1/4	SW 1 1/4	SWXT 1 1/4	PE 1 1/4	DN32				
	G 1 1/2	N 1 1/2	SW 1 1/2	SWXT 1 1/2	PE 1 1/2	DN40				
	G 2	N 2	SW 2	SWXT 2	PE 2	DN50				
	G 2 1/2	N 2 1/2	SW 2 1/2			DN65				
	G 3	N 3	SW 3			DN80				
	G 4	N 4	SW 4			DN100				

GM



2-WAY HIGH PRESSURE BALL VALVES

Specialist in Ball Valves

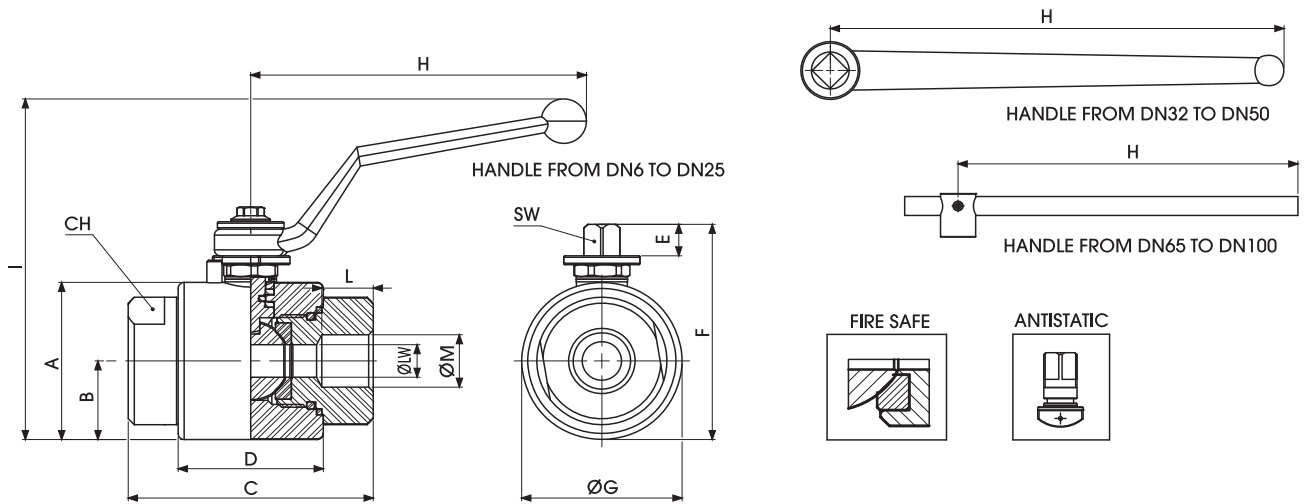

GM DIN/ISO 228 BSP

Standard

TYPE	DN	A	B	C	D	E	F	ØG	H	I	L	ØM	CH	SW	ØLW	KG
GM G 1/4	6	-	23,5	72	44	10,5	66,5	47	110	109	15,5	G 1/4	32	9	6	0,869
GM G 3/8	10	-	23,5	72	44	10,5	66,5	47	110	109	15,5	G 3/8	32	9	10	0,844
GM G 1/2	13	-	26,5	81	48	10,5	72,5	53	110	115	17	G 1/2	38	9	13	1,151
GM G 3/4	20	-	31,5	98	62	14	90	63	180	122	21	G 3/4	48	14	20	2,109
GM G 1	25	-	36,5	106	66	14	99	73	180	133	24	G 1	55	14	25	2,872
GM G 1 1/4	32	-	42	127	83	14	111	84	300	120,5	25	G 1 1/4	65	17	32	4,557
GM G 1 1/2	40	-	49,5	135	89	14	126	99	300	134,5	25	G 1 1/2	80	17	40	6,482
GM G 2	50	-	56	160	101	14	132	104	300	140,5	27	G 2	90	17	50	7,966
GM G 2 1/2	65	140	70	174	105	23,5	176,5	150	600	226	32	G 2 1/2	110	19	65	17,506
GM G 3	80	155	77,5	191,5	114	23,5	191	167	600	241	32	G 3	125	19	80	22,896
GM G 4	100	188	94	230	148	31	231,5	200	600	278,5	40	G 4	150	19	100	36,999



2-WAY HIGH PRESSURE BALL VALVES

www.gemels.it

(POM seal)

GM DIN/ISO 228 PN

DN	PN	GM DIN/ISO 228 PN	
		CARBON STEEL	STAINLESS STEEL
DN	PN	ITEM CODE	ITEM CODE
6	500	GM2GGT15024A000	GM2GGT15044A000
10	500	GM2GGT25024A000	GM2GGT25044A000
13	500	GM2GGT35024A000	GM2GGT35044A000
20	400	GM2GGT44024A000	GM2GGT44044A000
25	350	GM2GGT53024A000	GM2GGT53044A000
32	350	GM2GGT63024A000	GM2GGT63044A000
40	350	GM2GGT73024A000	GM2GGT73044A000
50	350	GM2GGT83024A000	GM2GGT83044A000
65	150	GM2GGT9C024A000	GM2GGT9C044A000
80	100	GM2GGTA1024A000	GM2GGTA1044A000
100	50	GM2GGTB1024A000	GM2GGTB1044A000

(POM seal)

GM DIN/ISO 228 S3000

DN	PN	GM DIN/ISO 228 S3000	
		CARBON STEEL	STAINLESS STEEL
DN	PN	ITEM CODE	ITEM CODE
6	S3000	GM2GGT1F024A000	GM2GGT1F044A000
10	S3000	GM2GGT2F024A000	GM2GGT2F044A000
13	S3000	GM2GGT3F024A000	GM2GGT3F044A000
20	S3000	GM2GGT4F024A000	GM2GGT4F044A000
25	S3000	GM2GGT5F024A000	GM2GGT5F044A000
32	S3000	GM2GGT6F024A000	GM2GGT6F044A000
40	S3000	GM2GGT7F024A000	GM2GGT7F044A000
50	S3000	GM2GGT8F024A000	GM2GGT8F044A000
65	S3000 (15 Mpa)	GM2GGT9F024A000	GM2GGT9F044A000
80	S3000 (10 Mpa)	GM2GGTAF024A000	GM2GGTAF044A000
100	S3000 (5 Mpa)	GM2GGTBF024A000	GM2GGTBF044A000

(PEEK seal)

GM DIN/ISO 228 PN

DN	PN	GM DIN/ISO 228 PN	
		CARBON STEEL	STAINLESS STEEL
DN	PN	ITEM CODE	ITEM CODE
6	500	GM2GGT15024P000	GM2GGT15044P000
10	500	GM2GGT25024P000	GM2GGT25044P000
13	500	GM2GGT35024P000	GM2GGT35044P000
20	400	GM2GGT44024P000	GM2GGT44044P000
25	350	GM2GGT53024P000	GM2GGT53044P000
32	350	GM2GGT63024P000	GM2GGT63044P000
40	350	GM2GGT73024P000	GM2GGT73044P000
50	350	GM2GGT83024P000	GM2GGT83044P000
65	150	GM2GGT9C024P000	GM2GGT9C044P000
80	100	GM2GGTA1024P000	GM2GGTA1044P000
100	50	GM2GGTB1024P000	GM2GGTB1044P000

(PEEK seal)

GM DIN/ISO 228 S3000

DN	PN	GM DIN/ISO 228 S3000	
		CARBON STEEL	STAINLESS STEEL
DN	PN	ITEM CODE	ITEM CODE
6	S3000	GM2GGT1F024P000	GM2GGT1F044P000
10	S3000	GM2GGT2F024P000	GM2GGT2F044P000
13	S3000	GM2GGT3F024P000	GM2GGT3F044P000
20	S3000	GM2GGT4F024P000	GM2GGT4F044P000
25	S3000	GM2GGT5F024P000	GM2GGT5F044P000
32	S3000	GM2GGT6F024P000	GM2GGT6F044P000
40	S3000	GM2GGT7F024P000	GM2GGT7F044P000
50	S3000	GM2GGT8F024P000	GM2GGT8F044P000
65	S3000 (15 Mpa)	GM2GGT9F024P000	GM2GGT9F044P000
80	S3000 (10 Mpa)	GM2GGTAF024P000	GM2GGTAF044P000
100	S3000 (5 Mpa)	GM2GGTBF024P000	GM2GGTBF044P000

(PTFE seal)

GM DIN/ISO 228 S800

DN	PN	GM DIN/ISO 228 S800	
		CARBON STEEL	STAINLESS STEEL
DN	PN	ITEM CODE	ITEM CODE
6	S800	GM2GGT1A024F000	GM2GGT1A044F000
10	S800	GM2GGT2A024F000	GM2GGT2A044F000
13	S800	GM2GGT3A024F000	GM2GGT3A044F000
20	S800	GM2GGT4A024F000	GM2GGT4A044F000
25	S800	GM2GGT5A024F000	GM2GGT5A044F000
32	S800	GM2GGT6A024F000	GM2GGT6A044F000
40	S800	GM2GGT7A024F000	GM2GGT7A044F000
50	S800	GM2GGT8A024F000	GM2GGT8A044F000
65	S800	GM2GGT9A024F000	GM2GGT9A044F000
80	S800	GM2GGTAA024F000	GM2GGTAA044F000
100	S800	GM2GGTBA024F000	GM2GGTBA044F000





2-WAY HIGH PRESSURE BALL VALVES

Specialist in Ball Valves

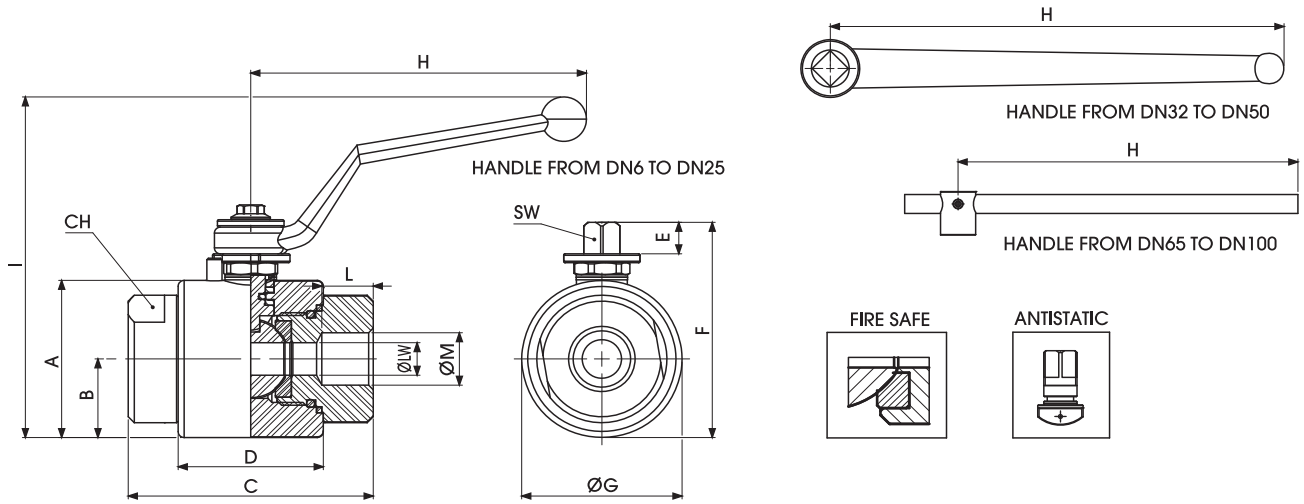

GM ANSI/ASME B1.20.1 NPT

Standard

TYPE	DN	A	B	C	D	E	F	ØG	H	I	L	ØM	CH	SW	ØLW	KG
GM N 1/4	6	-	23,5	72	44	10,5	66,5	47	110	109	17	N 1/4	32	9	6	0,869
GM N 3/8	10	-	23,5	72	44	10,5	66,5	47	110	109	17	N 3/8	32	9	10	0,844
GM N 1/2	13	-	26,5	81	48	10,5	72,5	53	110	115	21	N 1/2	38	9	13	1,151
GM N 3/4	20	-	31,5	98	62	14	90	63	180	122	21	N 3/4	48	14	20	2,109
GM N 1	25	-	36,5	106	66	14	99	73	180	133	24	N 1	55	14	25	2,872
GM N 1 1/4	32	-	42	127	83	14	111	84	300	120,5	25	N 1 1/4	65	17	32	4,557
GM N 1 1/2	40	-	49,5	135	89	14	126	99	300	134,5	25	N 1 1/2	80	17	40	6,482
GM N 2	50	-	56	160	101	14	132	104	300	140,5	27	N 2	90	17	50	7,966
GM N 2 1/2	65	140	70	174	105	23,5	176,5	150	600	226	32	N 2 1/2	110	19	65	17,506
GM N 3	80	155	77,5	191,5	114	23,5	191	167	600	241	32	N 3	125	19	80	22,896
GM N 4	100	188	94	230	148	31	231,5	200	600	278,5	40	N 4	150	19	100	36,999



2-WAY HIGH PRESSURE BALL VALVES

www.gemels.it

(POM seal) GM ANSI/ASME B1.20.1 NPT PN

DN	PN	CARBON STEEL	STAINLESS STEEL
		ITEM CODE	ITEM CODE
6	500	GM2NNT15024A000	GM2NNT15044A000
10	500	GM2NNT25024A000	GM2NNT25044A000
13	500	GM2NNT35024A000	GM2NNT35044A000
20	400	GM2NNT44024A000	GM2NNT44044A000
25	350	GM2NNT53024A000	GM2NNT53044A000
32	350	GM2NNT63024A000	GM2NNT63044A000
40	350	GM2NNT73024A000	GM2NNT73044A000
50	350	GM2NNT83024A000	GM2NNT83044A000
65	150	GM2NNT9C024A000	GM2NNT9C044A000
80	100	GM2NNTA1024A000	GM2NNTA1044A000
100	50	GM2NNTBI024A000	GM2NNTBI044A000

(POM seal) GM ANSI/ASME B1.20.1 NPT S3000

DN	PN	CARBON STEEL	STAINLESS STEEL
		ITEM CODE	ITEM CODE
6	S3000	GM2NNT1F024A000	GM2NNT1F044A000
10	S3000	GM2NNT2F024A000	GM2NNT2F044A000
13	S3000	GM2NNT3F024A000	GM2NNT3F044A000
20	S3000	GM2NNT4F024A000	GM2NNT4F044A000
25	S3000	GM2NNT5F024A000	GM2NNT5F044A000
32	S3000	GM2NNT6F024A000	GM2NNT6F044A000
40	S3000	GM2NNT7F024A000	GM2NNT7F044A000
50	S3000	GM2NNT8F024A000	GM2NNT8F044A000
65	S3000 (15 Mpa)	GM2NNT9F024A000	GM2NNT9F044A000
80	S3000 (10 Mpa)	GM2NNTAF024A000	GM2NNTAF044A000
100	S3000 (5 Mpa)	GM2NNTBF024A000	GM2NNTBF044A000

(PEEK seal) GM ANSI/ASME B1.20.1 NPT PN

DN	PN	CARBON STEEL	STAINLESS STEEL
		ITEM CODE	ITEM CODE
6	500	GM2NNT15024P000	GM2NNT15044P000
10	500	GM2NNT25024P000	GM2NNT25044P000
13	500	GM2NNT35024P000	GM2NNT35044P000
20	400	GM2NNT44024P000	GM2NNT44044P000
25	350	GM2NNT53024P000	GM2NNT53044P000
32	350	GM2NNT63024P000	GM2NNT63044P000
40	350	GM2NNT73024P000	GM2NNT73044P000
50	350	GM2NNT83024P000	GM2NNT83044P000
65	150	GM2NNT9C024P000	GM2NNT9C044P000
80	100	GM2NNTA1024P000	GM2NNTA1044P000
100	50	GM2NNTBI024P000	GM2NNTBI044P000

(PEEK seal) GM ANSI/ASME B1.20.1 NPT S3000

DN	PN	CARBON STEEL	STAINLESS STEEL
		ITEM CODE	ITEM CODE
6	S3000	GM2NNT1F024P000	GM2NNT1F044P000
10	S3000	GM2NNT2F024P000	GM2NNT2F044P000
13	S3000	GM2NNT3F024P000	GM2NNT3F044P000
20	S3000	GM2NNT4F024P000	GM2NNT4F044P000
25	S3000	GM2NNT5F024P000	GM2NNT5F044P000
32	S3000	GM2NNT6F024P000	GM2NNT6F044P000
40	S3000	GM2NNT7F024P000	GM2NNT7F044P000
50	S3000	GM2NNT8F024P000	GM2NNT8F044P000
65	S3000 (15 Mpa)	GM2NNT9F024P000	GM2NNT9F044P000
80	S3000 (10 Mpa)	GM2NNTAF024P000	GM2NNTAF044P000
100	S3000 (5 Mpa)	GM2NNTBF024P000	GM2NNTBF044P000

(PTFE seal) GM ANSI/ASME B1.20.1 NPT S800

DN	PN	CARBON STEEL	STAINLESS STEEL
		ITEM CODE	ITEM CODE
6	S800	GM2NNT1A024F000	GM2NNT1A044F000
10	S800	GM2NNT2A024F000	GM2NNT2A044F000
13	S800	GM2NNT3A024F000	GM2NNT3A044F000
20	S800	GM2NNT4A024F000	GM2NNT4A044F000
25	S800	GM2NNT5A024F000	GM2NNT5A044F000
32	S800	GM2NNT6A024F000	GM2NNT6A044F000
40	S800	GM2NNT7A024F000	GM2NNT7A044F000
50	S800	GM2NNT8A024F000	GM2NNT8A044F000
65	S800	GM2NNT9A024F000	GM2NNT9A044F000
80	S800	GM2NNTAA024F000	GM2NNTAA044F000
100	S800	GM2NNTBA024F000	GM2NNTBA044F000





2-WAY HIGH PRESSURE BALL VALVES

Specialist in Ball Valves

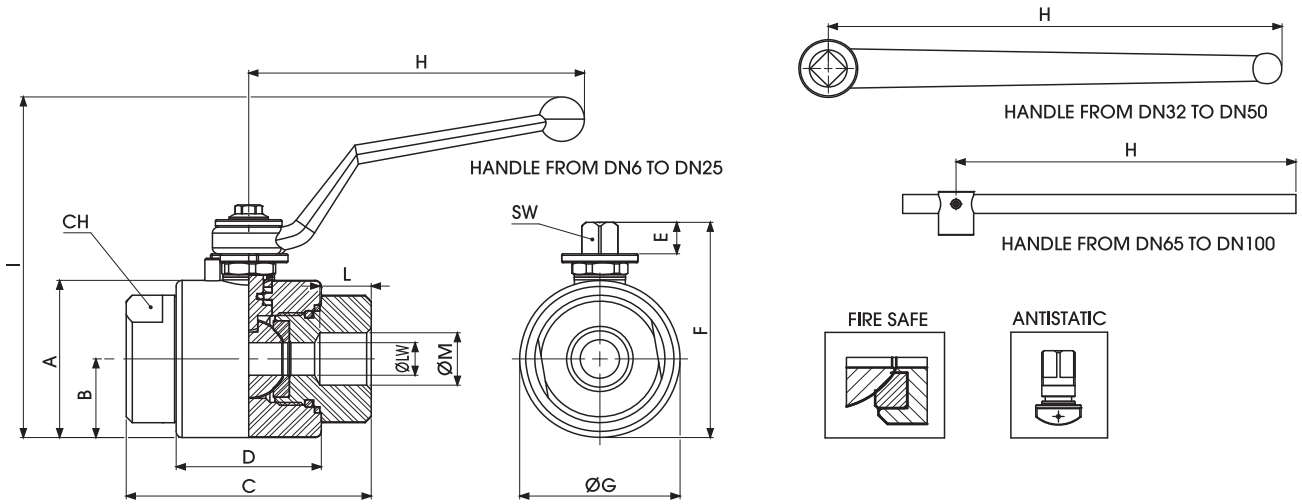

GM SW

Standard

TYPE	DN	A	B	C	D	E	F	ØG	H	I	L	ØM	CH	SW	ØLW	KG
GM SW 1/4	6	-	23,5	72	44	10,5	66,5	47	110	109	11,1	14,1	32	9	6	0,869
GM SW 3/8	10	-	23,5	72	44	10,5	66,5	47	110	109	11,1	17,53	32	9	10	0,844
GM SW 1/2	13	-	26,5	81	48	10,5	72,5	53	110	115	12,7	21,72	38	9	13	1,151
GM SW 3/4	20	-	31,5	98	62	14	90	63	180	122	15	27,05	48	14	20	2,109
GM SW 1	25	-	36,5	106	66	14	99	73	180	133	16	33,78	55	14	25	2,872
GM SW 1 1/4	32	-	42	127	83	14	111	84	300	120,5	17,5	42,7	65	17	32	4,557
GM SW 1 1/2	40	-	49,5	135	89	14	126	99	300	134,5	19	48,64	80	17	40	6,482
GM SW 2	50	-	56	160	101	14	132	104	300	140,5	22	61,2	90	17	50	7,966
GM SW 2 1/2	65	140	70	174	105	23,5	176,5	150	600	226	30	73,9	110	19	65	17,506
GM SW 3	80	155	77,5	191,5	114	23,5	191	167	600	241	30	89,8	125	19	80	22,896
GM SW 4	100	188	94	230	148	31	231,5	200	600	278,5	30	115,2	150	19	100	36,999



2-WAY HIGH PRESSURE BALL VALVES

www.gemels.it

(POM seal)

GM SW PN

DN	PN	GM SW PN	
		CARBON STEEL	STAINLESS STEEL
DN	PN	ITEM CODE	ITEM CODE
6	500	GM2TTT15024A000	GM2TTT15044A000
10	500	GM2TTT25024A000	GM2TTT25044A000
13	500	GM2TTT35024A000	GM2TTT35044A000
20	400	GM2TTT44024A000	GM2TTT44044A000
25	350	GM2TTT53024A000	GM2TTT53044A000
32	350	GM2TTT63024A000	GM2TTT63044A000
40	350	GM2TTT73024A000	GM2TTT73044A000
50	350	GM2TTT83024A000	GM2TTT83044A000
65	150	GM2TTT9C024A000	GM2TTT9C044A000
80	100	GM2TTTA1024A000	GM2TTTA1044A000
100	50	GM2TTTB1024A000	GM2TTTB1044A000

(POM seal)

GM SW S3000

DN	PN	GM SW S3000	
		CARBON STEEL	STAINLESS STEEL
DN	PN	ITEM CODE	ITEM CODE
6	S3000	GM2TTT1F024A000	GM2TTT1F044A000
10	S3000	GM2TTT2F024A000	GM2TTT2F044A000
13	S3000	GM2TTT3F024A000	GM2TTT3F044A000
20	S3000	GM2TTT4F024A000	GM2TTT4F044A000
25	S3000	GM2TTT5F024A000	GM2TTT5F044A000
32	S3000	GM2TTT6F024A000	GM2TTT6F044A000
40	S3000	GM2TTT7F024A000	GM2TTT7F044A000
50	S3000	GM2TTT8F024A000	GM2TTT8F044A000
65	S3000 (15 Mpa)	GM2TTT9F024A000	GM2TTT9F044A000
80	S3000 (10 Mpa)	GM2TTTAF024A000	GM2TTTAF044A000
100	S3000 (5 Mpa)	GM2TTTB024A000	GM2TTTB044A000

(PEEK seal)

GM SW PN

DN	PN	GM SW PN	
		CARBON STEEL	STAINLESS STEEL
DN	PN	ITEM CODE	ITEM CODE
6	500	GM2TTT15024P000	GM2TTT15044P000
10	500	GM2TTT25024P000	GM2TTT25044P000
13	500	GM2TTT35024P000	GM2TTT35044P000
20	400	GM2TTT44024P000	GM2TTT44044P000
25	350	GM2TTT53024P000	GM2TTT53044P000
32	350	GM2TTT63024P000	GM2TTT63044P000
40	350	GM2TTT73024P000	GM2TTT73044P000
50	350	GM2TTT83024P000	GM2TTT83044P000
65	150	GM2TTT9C024P000	GM2TTT9C044P000
80	100	GM2TTTA1024P000	GM2TTTA1044P000
100	50	GM2TTTB1024P000	GM2TTTB1044P000

(PEEK seal)

GM SW S3000

DN	PN	GM SW S3000	
		CARBON STEEL	STAINLESS STEEL
DN	PN	ITEM CODE	ITEM CODE
6	S3000	GM2TTT1F024P000	GM2TTT1F044P000
10	S3000	GM2TTT2F024P000	GM2TTT2F044P000
13	S3000	GM2TTT3F024P000	GM2TTT3F044P000
20	S3000	GM2TTT4F024P000	GM2TTT4F044P000
25	S3000	GM2TTT5F024P000	GM2TTT5F044P000
32	S3000	GM2TTT6F024P000	GM2TTT6F044P000
40	S3000	GM2TTT7F024P000	GM2TTT7F044P000
50	S3000	GM2TTT8F024P000	GM2TTT8F044P000
65	S3000 (15 Mpa)	GM2TTT9F024P000	GM2TTT9F044P000
80	S3000 (10 Mpa)	GM2TTTAF024P000	GM2TTTAF044P000
100	S3000 (5 Mpa)	GM2TTTB024P000	GM2TTTB044P000

(PTFE seal)

GM SW S800

DN	PN	GM SW S800	
		CARBON STEEL	STAINLESS STEEL
DN	PN	ITEM CODE	ITEM CODE
6	S800	GM2TTT1A024F000	GM2TTT1A044F000
10	S800	GM2TTT2A024F000	GM2TTT2A044F000
13	S800	GM2TTT3A024F000	GM2TTT3A044F000
20	S800	GM2TTT4A024F000	GM2TTT4A044F000
25	S800	GM2TTT5A024F000	GM2TTT5A044F000
32	S800	GM2TTT6A024F000	GM2TTT6A044F000
40	S800	GM2TTT7A024F000	GM2TTT7A044F000
50	S800	GM2TTT8A024F000	GM2TTT8A044F000





2-WAY HIGH PRESSURE BALL VALVES

Specialist in Ball Valves

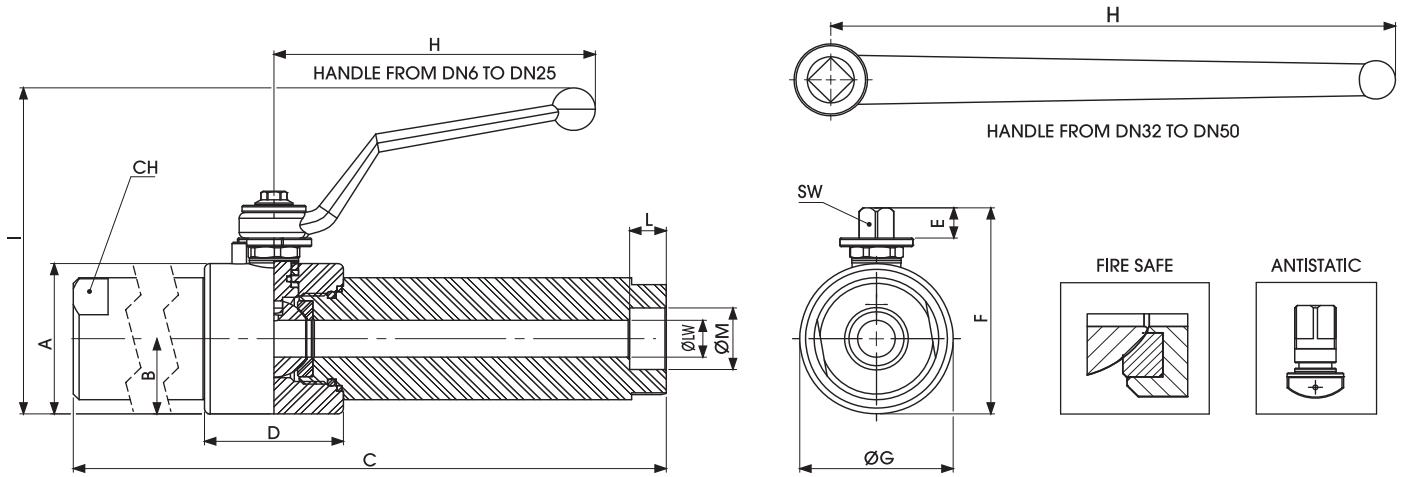

GM SW EXTRALONG

Standard

TYPE	DN	A	B	C	D	E	F	ØG	H	I	L	ØM	CH	SW	ØLW	KG
GM SWXT 1/4	6	-	23,5	262	44	10,5	66,5	47	110	109	11,1	14,1	32	9	6	2,529
GM SWXT 3/8	10	-	23,5	262	44	10,5	66,5	47	110	109	11,1	17,53	32	9	10	2,427
GM SWXT 1/2	13	-	26,5	271	48	10,5	72,5	53	110	115	12,7	21,72	38	9	13	3,126
GM SWXT 3/4	20	-	31,5	288	62	14	90	63	180	122	15	27,05	48	14	20	5,056
GM SWXT 1	25	-	36,5	296	66	14	99	73	180	133	16	33,78	55	14	25	6,956
GM SWXT 1 1/4	32	-	42	318	83	14	111	84	300	120,5	17,5	42,7	65	17	32	9,83
GM SWXT 1 1/2	40	-	49,5	325	89	14	126	99	300	134,5	19	48,64	80	17	40	13,883
GM SWXT 2	50	-	56	350	101	14	132	104	300	140,5	22	61,2	90	17	50	16,773



2-WAY HIGH PRESSURE BALL VALVES

www.gemels.it

(POM seal) GM SW EXTRALONG PN

DN	PN	GM SW EXTRALONG PN	
		CARBON STEEL	STAINLESS STEEL
DN	PN	ITEM CODE	ITEM CODE
6	500	GM2TXT15024A000	GM2TXT15044A000
10	500	GM2TXT25024A000	GM2TXT25044A000
13	500	GM2TXT35024A000	GM2TXT35044A000
20	400	GM2TXT44024A000	GM2TXT44044A000
25	350	GM2TXT53024A000	GM2TXT53044A000
32	350	GM2TXT63024A000	GM2TXT63044A000
40	350	GM2TXT73024A000	GM2TXT73044A000
50	350	GM2TXT83024A000	GM2TXT83044A000

(POM seal) GM SW EXTRALONG S3000

DN	PN	GM SW EXTRALONG S3000	
		CARBON STEEL	STAINLESS STEEL
DN	PN	ITEM CODE	ITEM CODE
6	S3000	GM2TXT1F024A000	GM2TXT1F044A000
10	S3000	GM2TXT2F024A000	GM2TXT2F044A000
13	S3000	GM2TXT3F024A000	GM2TXT3F044A000
20	S3000	GM2TXT4F024A000	GM2TXT4F044A000
25	S3000	GM2TXT5F024A000	GM2TXT5F044A000
32	S3000	GM2TXT6F024A000	GM2TXT6F044A000
40	S3000	GM2TXT7F024A000	GM2TXT7F044A000
50	S3000	GM2TXT8F024A000	GM2TXT8F044A000

(PEEK seal) GM SW EXTRALONG PN

DN	PN	GM SW EXTRALONG PN	
		CARBON STEEL	STAINLESS STEEL
DN	PN	ITEM CODE	ITEM CODE
6	500	GM2TXT15024P000	GM2TXT15044P000
10	500	GM2TXT25024P000	GM2TXT25044P000
13	500	GM2TXT35024P000	GM2TXT35044P000
20	400	GM2TXT44024P000	GM2TXT44044P000
25	350	GM2TXT53024P000	GM2TXT53044P000
32	350	GM2TXT63024P000	GM2TXT63044P000
40	350	GM2TXT73024P000	GM2TXT73044P000
50	350	GM2TXT83024P000	GM2TXT83044P000

(PEEK seal) GM SW EXTRALONG S3000

DN	PN	GM SW EXTRALONG S3000	
		CARBON STEEL	STAINLESS STEEL
DN	PN	ITEM CODE	ITEM CODE
6	S3000	GM2TXT1F024P000	GM2TXT1F044P000
10	S3000	GM2TXT2F024P000	GM2TXT2F044P000
13	S3000	GM2TXT3F024P000	GM2TXT3F044P000
20	S3000	GM2TXT4F024P000	GM2TXT4F044P000
25	S3000	GM2TXT5F024P000	GM2TXT5F044P000
32	S3000	GM2TXT6F024P000	GM2TXT6F044P000
40	S3000	GM2TXT7F024P000	GM2TXT7F044P000
50	S3000	GM2TXT8F024P000	GM2TXT8F044P000

(PTFE seal) GM SW EXTRALONG S800

DN	PN	GM SW EXTRALONG S800	
		CARBON STEEL	STAINLESS STEEL
DN	PN	ITEM CODE	ITEM CODE
6	S800	GM2TXT1A024F000	GM2TXT1A044F000
10	S800	GM2TXT2A024F000	GM2TXT2A044F000
13	S800	GM2TXT3A024F000	GM2TXT3A044F000
20	S800	GM2TXT4A024F000	GM2TXT4A044F000
25	S800	GM2TXT5A024F000	GM2TXT5A044F000
32	S800	GM2TXT6A024F000	GM2TXT6A044F000
40	S800	GM2TXT7A024F000	GM2TXT7A044F000
50	S800	GM2TXT8A024F000	GM2TXT8A044F000





2-WAY HIGH PRESSURE BALL VALVES

Specialist in Ball Valves

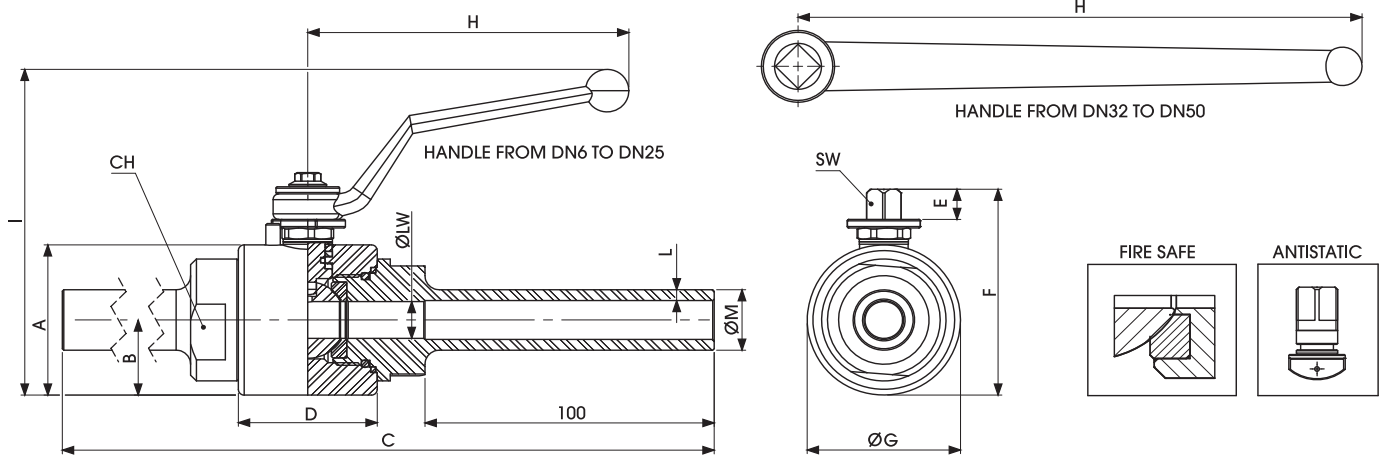

GM PE

Standard

TYPE	DN	A	B	C	D	E	F	ØG	H	I	L SCH80	ØM	CH	SW	ØLW	KG
GM PE 1/4	6	-	23,5	272	44	10,5	66,5	47	110	109	3,02	13,7	32	9	6	1,054
GM PE 3/8	10	-	23,5	272	44	10,5	66,5	47	110	109	3,2	17,1	32	9	10	1,093
GM PE 1/2	13	-	26,5	281	48	10,5	72,5	53	110	115	3,73	21,3	38	9	13	1,528
GM PE 3/4	20	-	31,5	298	62	14	90	63	180	122	3,91	26,7	48	14	20	2,63
GM PE 1	25	-	36,5	306	66	14	99	73	180	133	4,55	33,4	55	14	25	3,646
GM PE 1 1/4	32	-	42	327	83	14	111	84	300	120,5	4,85	42,2	65	17	32	5,638
GM PE 1 1/2	40	-	49,5	335	89	14	126	99	300	134,5	5,08	48,3	80	17	40	7,73
GM PE 2	50	-	56	360	101	14	132	104	300	140,5	5,54	60,3	90	17	50	9,827

"The company reserves the right to operate dimensional changes without prior notice".



2-WAY HIGH PRESSURE BALL VALVES

www.gemels.it

(POM seal)

GM PE PN

DN	PN	ITEM CODE	
		CARBON STEEL	STAINLESS STEEL
6	500	GM2BWT15024A000	GM2BWT15044A000
10	500	GM2BWT25024A000	GM2BWT25044A000
13	500	GM2BWT35024A000	GM2BWT35044A000
20	400	GM2BWT44024A000	GM2BWT44044A000
25	350	GM2BWT53024A000	GM2BWT53044A000
32	350	GM2BWT63024A000	GM2BWT63044A000
40	350	GM2BWT73024A000	GM2BWT73044A000
50	350	GM2BWT83024A000	GM2BWT83044A000

(POM seal)

GM PE S3000

DN	PN	ITEM CODE	
		CARBON STEEL	STAINLESS STEEL
6	S3000	GM2BWT1F024A000	GM2BWT1F044A000
10	S3000	GM2BWT2F024A000	GM2BWT2F044A000
13	S3000	GM2BWT3F024A000	GM2BWT3F044A000
20	S3000	GM2BWT4F024A000	GM2BWT4F044A000
25	S3000	GM2BWT5F024A000	GM2BWT5F044A000
32	S3000	GM2BWT6F024A000	GM2BWT6F044A000
40	S3000	GM2BWT7F024A000	GM2BWT7F044A000
50	S3000	GM2BWT8F024A000	GM2BWT8F044A000

(PEEK seal)

GM PE PN

DN	PN	ITEM CODE	
		CARBON STEEL	STAINLESS STEEL
6	500	GM2BWT15024P000	GM2BWT15044P000
10	500	GM2BWT25024P000	GM2BWT25044P000
13	500	GM2BWT35024P000	GM2BWT35044P000
20	400	GM2BWT44024P000	GM2BWT44044P000
25	350	GM2BWT53024P000	GM2BWT53044P000
32	350	GM2BWT63024P000	GM2BWT63044P000
40	350	GM2BWT73024P000	GM2BWT73044P000
50	350	GM2BWT83024P000	GM2BWT83044P000

(PEEK seal)

GM PE S3000

DN	PN	ITEM CODE	
		CARBON STEEL	STAINLESS STEEL
6	S3000	GM2BWT1F024P000	GM2BWT1F044P000
10	S3000	GM2BWT2F024P000	GM2BWT2F044P000
13	S3000	GM2BWT3F024P000	GM2BWT3F044P000
20	S3000	GM2BWT4F024P000	GM2BWT4F044P000
25	S3000	GM2BWT5F024P000	GM2BWT5F044P000
32	S3000	GM2BWT6F024P000	GM2BWT6F044P000
40	S3000	GM2BWT7F024P000	GM2BWT7F044P000
50	S3000	GM2BWT8F024P000	GM2BWT8F044P000

(PTFE seal)

GM PE S800

DN	PN	ITEM CODE	
		CARBON STEEL	STAINLESS STEEL
6	S800	GM2BWT1A024F000	GM2BWT1A044F000
10	S800	GM2BWT2A024F000	GM2BWT2A044F000
13	S800	GM2BWT3A024F000	GM2BWT3A044F000
20	S800	GM2BWT4A024F000	GM2BWT4A044F000
25	S800	GM2BWT5A024F000	GM2BWT5A044F000
32	S800	GM2BWT6A024F000	GM2BWT6A044F000
40	S800	GM2BWT7A024F000	GM2BWT7A044F000
50	S800	GM2BWT8A024F000	GM2BWT8A044F000



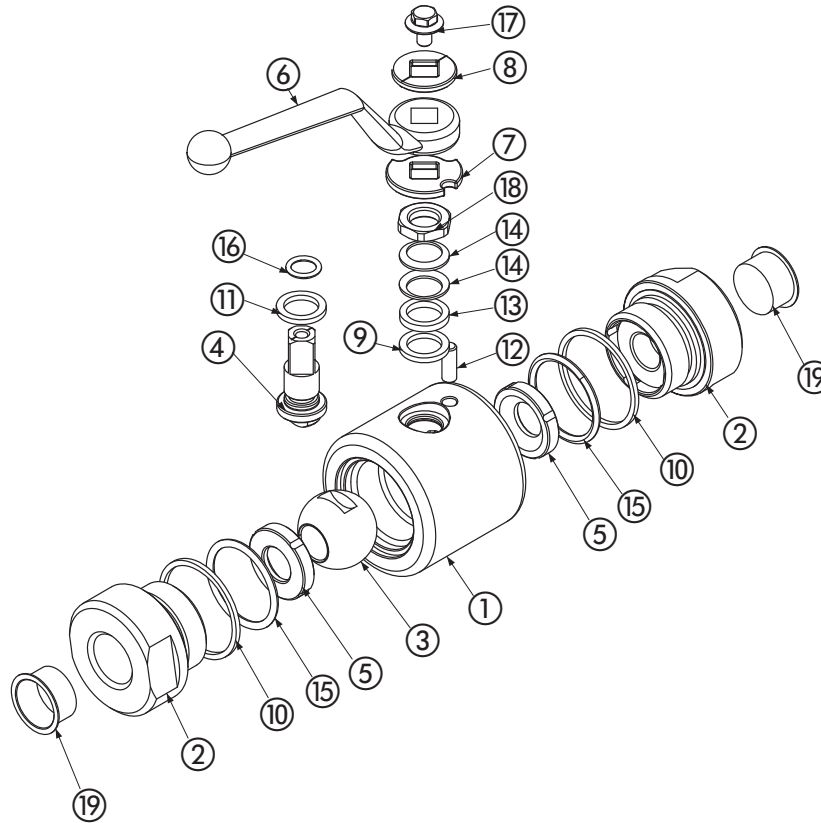

Carbon steel

Pos	Description	Material	Q.tà
1	Body	1,0570	1
2	Adapter	1,0570	2
3	Ball	1,4404	1
4	Stem	1,4404	1
5	Ball Seat	PTFE	2
6	Handle	1,0116	1
7	Washer	1,4301	1
8	Washer	1,4301	1
9	Body ring	GRAPHITE	1
10	Adapter ring	GRAPHITE	2
11	Stem ring	PTFE	2
12	Spine	1,4301	1
13	Press ring	1,4301	1
14	Spring	1,4301	2
15	Adapter o-ring	NBR	2
16	Stem o-ring	NBR	1
17	Screw	DIN6921 A2	1
18	Nut	1,4301	1
19	Caps	PVC	2

- On request**
- Reduced bore
 - O-Ring in FKM, EPDM, HNBR, KALREZ
 - Seals in PTFE, PEEK, PA612, GEMPTFE, METAL TO METAL
 - Special threads
 - Pressure class up to PN500 or 3000 Psi
 - Locking device

Stainless steel

Pos	Description	Material	Q.tà
1	Body	1,4404	1
2	Adapter	1,4404	2
3	Ball	1,4404	1
4	Stem	1,4404	1
5	Ball Seat	PTFE	2
6	Handle	1,0116	1
7	Washer	1,4301	1
8	Washer	1,4301	1
9	Body ring	GRAPHITE	1
10	Adapter ring	GRAPHITE	2
11	Stem ring	PTFE	2
12	Spine	1,4301	1
13	Press ring	1,4301	1
14	Spring	1,4301	2
15	Adapter o-ring	NBR	2
16	Stem o-ring	NBR	1
17	Screw	DIN6921 A2	1
18	Nut	1,4301	1
19	Caps	PVC	2

- On request**
- Reduced bore
 - O-Ring in FKM, EPDM, HNBR, KALREZ
 - Seals in PTFE, PEEK, PA612, GEMPTFE, METAL TO METAL
 - Special threads
 - Pressure class up to PN500 or 3000 Psi
 - Locking device

For further special requests please consult our technical/commercial service

+ GN

2-WAY HIGH PRESSURE BALL VALVES



CARBON STEEL

- Type: ball valve GN 2way
- Body: round
- Material: 1,0570/1,4404
- Ball seats: from DN6 up to DN50
- O-Rings: NBR, FKM, EPDM, MVQ
- Operating pressure: 350 Bar to 500 Bar S3000 to S6000 PN depending on valve size and seal materials selected
- Fire safe BS 6755
- Antistatic device
- Temp range: -46°C to +250°C depending on seal material selected

GN

G 1/2

DN13

LF2

316L

POM

B

Type and way of valve	GAS DIN/ISO 228 BSP	NPT ANSI/ASME B1.20.1	SW	SW EXTRALONG	PE	Nominal dimension	Body and adapter material	Stem and ball material	Ball seat material	Adapter and stem seal material
GN 2-way	G 1/4	N 1/4	SW 1/4	SWXT 1/4	PE 1/4	DN6			A POM	B NBR
	G 3/8	N 3/8	SW 3/8	SWXT 3/8	PE 3/8	DN10	LF2 1,0570	316L 1,4404	D PEEK	E FKM
	G 1/2	N 1/2	SW 1/2	SWXT 1/2	PE 1/2	DN13				F EPDM
	G 3/4	N 3/4	SW 3/4	SWXT 3/4	PE 3/4	DN20				L MVQ
	G 1	N 1	SW 1	SWXT 1	PE 1	DN25				
	G 1 1/4	N 1 1/4	SW 1 1/4	SWXT 1 1/4	PE 1 1/4	DN32				
	G 1 1/2	N 1 1/2	SW 1 1/2	SWXT 1 1/2	PE 1 1/2	DN40				
	G 2	N 2	SW 2	SWXT 2	PE 2	DN50				

STAINLESS STEEL

- Type: ball valve GN 2way
- Body: round
- Material: 1,4404
- Ball seats: from DN6 up to DN50
- O-Rings: NBR, FKM, EPDM, MVQ
- Operating pressure: 350 Bar to 500 Bar S3000 to S6000 PN depending on valve size and seal materials selected
- Fire safe BS 6755
- Antistatic device
- Temp range: -30°C to +100°C different temperatures on request

GN

G 1/2

DN13

316L

316L

POM

B

Type and way of valve	GAS DIN/ISO 228 BSP	NPT ANSI/ASME B1.20.1	SW	SW EXTRALONG	PE	Nominal dimension	Body and adapter material	Stem and ball material	Ball seat material	Adapter and stem seal material
GN 2-way	G 1/4	N 1/4	SW 1/4	SWXT 1/4	PE 1/4	DN6			A POM	B NBR
	G 3/8	N 3/8	SW 3/8	SWXT 3/8	PE 3/8	DN10	316L 1,4404	316L 1,4404	D PEEK	E FKM
	G 1/2	N 1/2	SW 1/2	SWXT 1/2	PE 1/2	DN13				F EPDM
	G 3/4	N 3/4	SW 3/4	SWXT 3/4	PE 3/4	DN20				L MVQ
	G 1	N 1	SW 1	SWXT 1	PE 1	DN25				
	G 1 1/4	N 1 1/4	SW 1 1/4	SWXT 1 1/4	PE 1 1/4	DN32				
	G 1 1/2	N 1 1/2	SW 1 1/2	SWXT 1 1/2	PE 1 1/2	DN40				
	G 2	N 2	SW 2	SWXT 2	PE 2	DN50				

GN

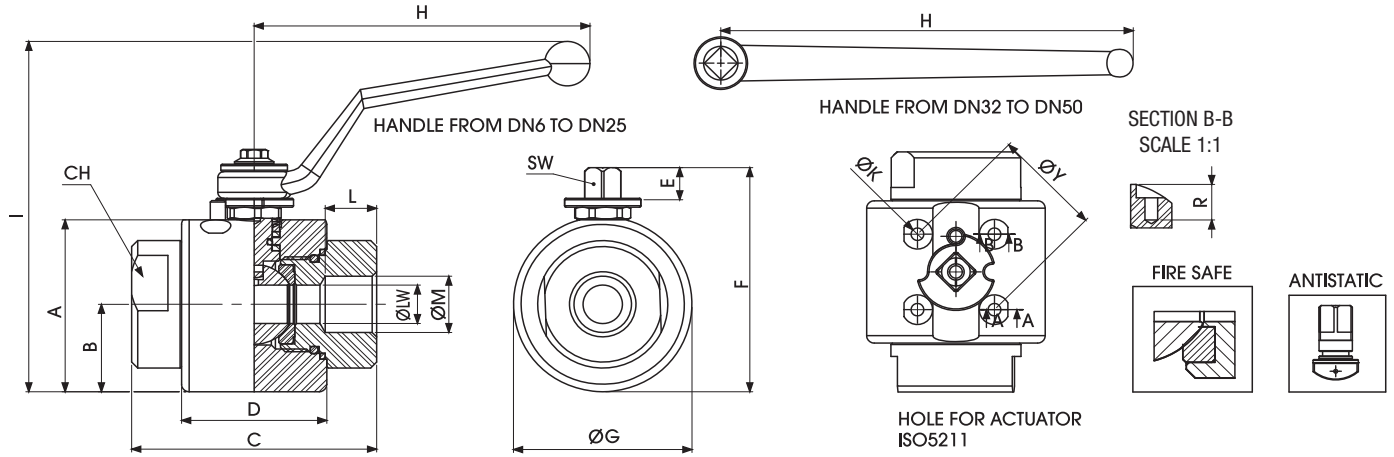

GN DIN/ISO 228 BSP

Standard

TYPE	DN	A	B	C	D	E	F	ØG	H	I	L	ØM	ØY	ØK	R	ISO 5211	CH	SW	ØLW	KG
GN G 1/4	6	53	27	72	44	10,5	70	54	110	113	15,5	G 1/4	36	M5	12	F03	32	9	6	1,042
GN G 3/8	10	53	27	72	44	10,5	70	54	110	113	15,5	G 3/8	36	M5	12	F03	32	9	10	1,016
GN G 1/2	13	58	29,5	81	48	10,5	75,5	59	110	118	17	G 1/2	36	M5	12	F03	38	9	13	1,328
GN G 3/4	20	72,5	37	98	62	14	95,5	74	180	128	21	G 3/4	50	M6	12	F05	48	14	20	2,638
GN G 1	25	81	41,5	106	66	14	104	83	180	137	24	G 1	50	M6	12	F05	55	14	25	3,45
GN G 1 1/4	32	96	49,5	127	83	14	118,5	99	300	128	25	G 1 1/4	70	M8	15	F07	65	17	32	5,851
GN G 1 1/2	40	109,5	57	135	89	14	132,5	114	300	142	25	G 1 1/2	70	M8	15	F07	80	17	40	8,065
GN G 2	50	118	61,5	160	101	14	141	123	300	150	27	G 2	70	M8	15	F07	90	17	50	10,412



2-WAY HIGH PRESSURE BALL VALVES

www.gemels.it

(POM seal) GN DIN/ISO 228 PN

		CARBON STEEL	STAINLESS STEEL
DN	PN	ITEM CODE	ITEM CODE
6	500	GN2GGT15024A000	GN2GGT15044A000
10	500	GN2GGT25024A000	GN2GGT25044A000
13	500	GN2GGT35024A000	GN2GGT35044A000
20	400	GN2GGT44024A000	GN2GGT44044A000
25	350	GN2GGT53024A000	GN2GGT53044A000
32	350	GN2GGT63024A000	GN2GGT63044A000
40	350	GN2GGT73024A000	GN2GGT73044A000
50	350	GN2GGT83024A000	GN2GGT83044A000

(POM seal) GN DIN/ISO 228 S6000

		CARBON STEEL	STAINLESS STEEL
DN	PN	ITEM CODE	ITEM CODE
6	S6000	GN2GGT1G024A000	GN2GGT1G044A000
10	S6000	GN2GGT2G024A000	GN2GGT2G044A000
13	S6000	GN2GGT3G024A000	GN2GGT3G044A000
20	S6000	GN2GGT4G024A000	GN2GGT4G044A000
25	S6000	GN2GGT5G024A000	GN2GGT5G044A000
32	S6000	GN2GGT6G024A000	GN2GGT6G044A000
40	S6000	GN2GGT7G024A000	GN2GGT7G044A000
50	S6000	GN2GGT8G024A000	GN2GGT8G044A000

(PEEK seal) GN DIN/ISO 228 PN

		CARBON STEEL	STAINLESS STEEL
DN	PN	ITEM CODE	ITEM CODE
6	500	GN2GGT15024P000	GN2GGT15044P000
10	500	GN2GGT25024P000	GN2GGT25044P000
13	500	GN2GGT35024P000	GN2GGT35044P000
20	400	GN2GGT44024P000	GN2GGT44044P000
25	350	GN2GGT53024P000	GN2GGT53044P000
32	350	GN2GGT63024P000	GN2GGT63044P000
40	350	GN2GGT73024P000	GN2GGT73044P000
50	350	GN2GGT83024P000	GN2GGT83044P000

(PEEK seal) GN DIN/ISO 228 S6000

		CARBON STEEL	STAINLESS STEEL
DN	PN	ITEM CODE	ITEM CODE
6	S6000	GN2GGT1G024P000	GN2GGT1G044P000
10	S6000	GN2GGT2G024P000	GN2GGT2G044P000
13	S6000	GN2GGT3G024P000	GN2GGT3G044P000
20	S6000	GN2GGT4G024P000	GN2GGT4G044P000
25	S6000	GN2GGT5G024P000	GN2GGT5G044P000
32	S6000	GN2GGT6G024P000	GN2GGT6G044P000
40	S6000	GN2GGT7G024P000	GN2GGT7G044P000
50	S6000	GN2GGT8G024P000	GN2GGT8G044P000



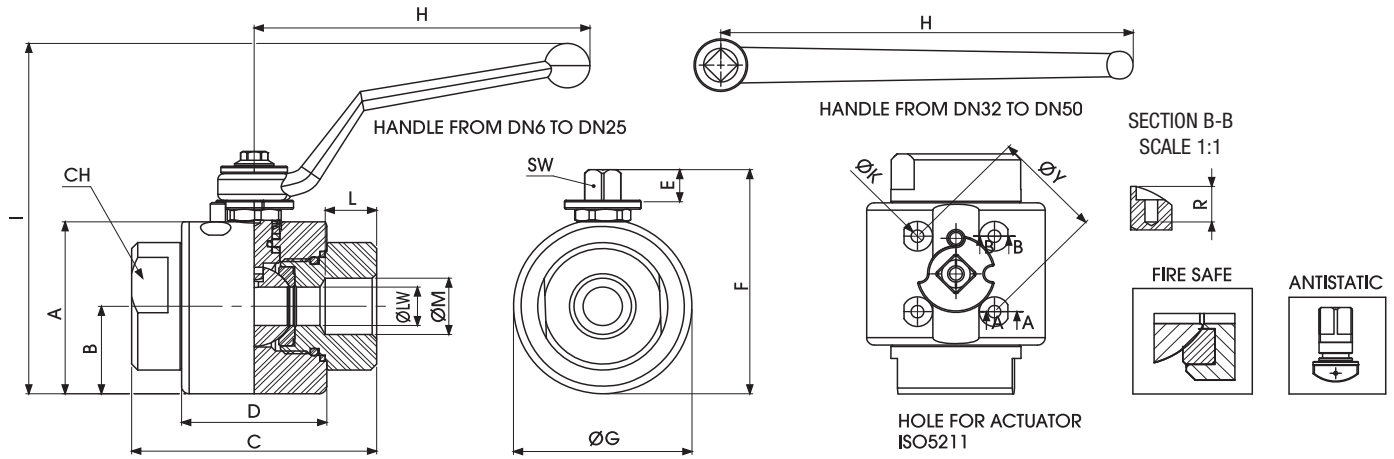

GN ANSI/ASME B1.20.1 NPT

Standard

TYPE	DN	A	B	C	D	E	F	ØG	H	I	L	ØM	ØY	ØK	R	ISO 5211	CH	SW	ØLW	KG
GN N 1/4	6	53	27	72	44	10,5	70	54	110	113	15,5	N 1/4	36	M5	12	F03	32	9	6	1,042
GN N 3/8	10	53	27	72	44	10,5	70	54	110	113	15,5	N 3/8	36	M5	12	F03	32	9	10	1,016
GN N 1/2	13	58	29,5	81	48	10,5	75,5	59	110	118	17	N 1/2	36	M5	12	F03	38	9	13	1,328
GN N 3/4	20	72,5	37	98	62	14	95,5	74	180	128	21	N 3/4	50	M6	12	F05	48	14	20	2,638
GN N 1	25	81	41,5	106	66	14	104	83	180	137	24	N 1	50	M6	12	F05	55	14	25	3,45
GN N 1 1/4	32	96	49,5	127	83	14	118,5	99	300	128	25	N 1 1/4	70	M8	15	F07	65	17	32	5,851
GN N 1 1/2	40	109,5	57	135	89	14	132,5	114	300	142	25	N 1 1/2	70	M8	15	F07	80	17	40	8,065
GN N 2	50	118	61,5	160	101	14	141	123	300	150	27	N 2	70	M8	15	F07	90	17	50	10,412



2-WAY HIGH PRESSURE BALL VALVES

www.gemels.it

(POM seal) GN ANSI/ASME B1.20.1 NPT PN

		CARBON STEEL	STAINLESS STEEL
DN	PN	ITEM CODE	ITEM CODE
6	500	GN2NNT15024A000	GN2NNT15044A000
10	500	GN2NNT25024A000	GN2NNT25044A000
13	500	GN2NNT35024A000	GN2NNT35044A000
20	400	GN2NNT44024A000	GN2NNT44044A000
25	350	GN2NNT53024A000	GN2NNT53044A000
32	350	GN2NNT63024A000	GN2NNT63044A000
40	350	GN2NNT73024A000	GN2NNT73044A000
50	350	GN2NNT83024A000	GN2NNT83044A000

(POM seal) GN ANSI/ASME B1.20.1 NPT S6000

		CARBON STEEL	STAINLESS STEEL
DN	PN	ITEM CODE	ITEM CODE
6	S6000	GN2NNT1G024A000	GN2NNT1G044A000
10	S6000	GN2NNT2G024A000	GN2NNT2G044A000
13	S6000	GN2NNT3G024A000	GN2NNT3G044A000
20	S6000	GN2NNT4G024A000	GN2NNT4G044A000
25	S6000	GN2NNT5G024A000	GN2NNT5G044A000
32	S6000	GN2NNT6G024A000	GN2NNT6G044A000
40	S6000	GN2NNT7G024A000	GN2NNT7G044A000
50	S6000	GN2NNT8G024A000	GN2NNT8G044A000

(PEEK seal) GN ANSI/ASME B1.20.1 NPT PN

		CARBON STEEL	STAINLESS STEEL
DN	PN	ITEM CODE	ITEM CODE
6	500	GN2NNT15024P000	GN2NNT15044P000
10	500	GN2NNT25024P000	GN2NNT25044P000
13	500	GN2NNT35024P000	GN2NNT35044P000
20	400	GN2NNT44024P000	GN2NNT44044P000
25	350	GN2NNT53024P000	GN2NNT53044P000
32	350	GN2NNT63024P000	GN2NNT63044P000
40	350	GN2NNT73024P000	GN2NNT73044P000
50	350	GN2NNT83024P000	GN2NNT83044P000

(PEEK seal) GN ANSI/ASME B1.20.1 NPT S6000

		CARBON STEEL	STAINLESS STEEL
DN	PN	ITEM CODE	ITEM CODE
6	S6000	GN2NNT1G024P000	GN2NNT1G044P000
10	S6000	GN2NNT2G024P000	GN2NNT2G044P000
13	S6000	GN2NNT3G024P000	GN2NNT3G044P000
20	S6000	GN2NNT4G024P000	GN2NNT4G044P000
25	S6000	GN2NNT5G024P000	GN2NNT5G044P000
32	S6000	GN2NNT6G024P000	GN2NNT6G044P000
40	S6000	GN2NNT7G024P000	GN2NNT7G044P000
50	S6000	GN2NNT8G024P000	GN2NNT8G044P000



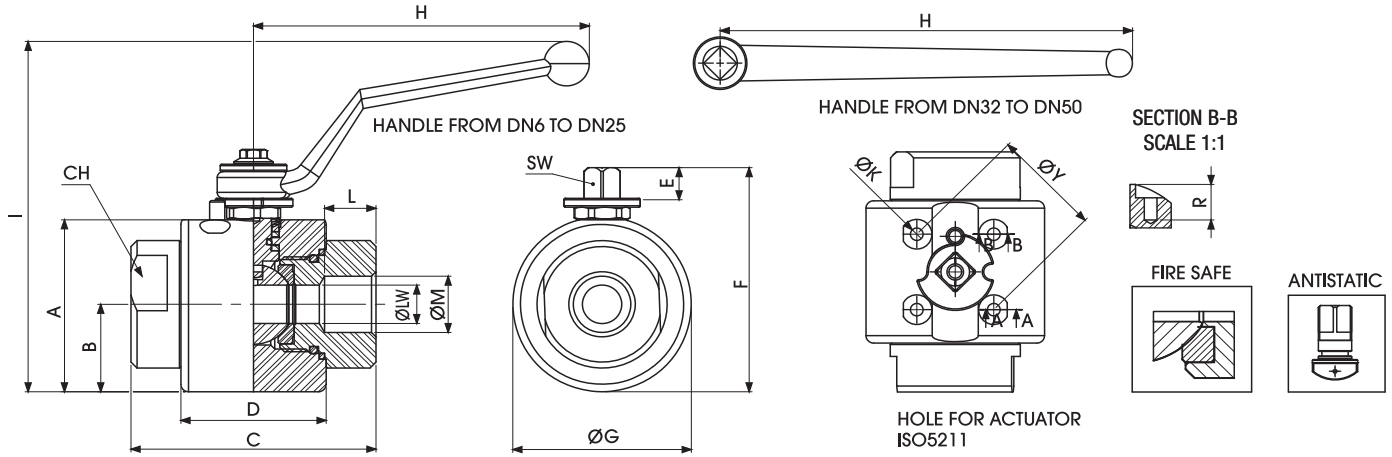

GN SW

Standard

TYPE	DN	A	B	C	D	E	F	ØG	H	I	L	ØM	ØY	ØK	R	ISO 5211	CH	SW	ØLW	KG
GN SW 1/4	6	53	27	72	44	10,5	70	54	110	113	11,1	14,1	36	M5	12	F03	32	9	6	1,042
GN SW 3/8	10	53	27	72	44	10,5	70	54	110	113	11,1	17,53	36	M5	12	F03	32	9	10	1,016
GN SW 1/2	13	58	29,5	81	48	10,5	75,5	59	110	118	12,7	21,72	36	M5	12	F03	38	9	13	1,328
GN SW 3/4	20	72,5	37	98	62	14	95,5	74	180	128	15	27,05	50	M6	12	F05	48	14	20	2,638
GN SW 1	25	81	41,5	106	66	14	104	83	180	137	16	33,78	50	M6	12	F05	55	14	25	3,45
GN SW 1 1/4	32	96	49,5	127	83	14	118,5	99	300	128	17,5	42,7	70	M8	15	F07	65	17	32	5,851
GN SW 1 1/2	40	109,5	57	135	89	14	132,5	114	300	142	19	48,64	70	M8	15	F07	80	17	40	8,065
GN SW 2	50	118	61,5	160	101	14	141	123	300	150	22	61,2	70	M8	15	F07	90	17	50	10,412



2-WAY HIGH PRESSURE BALL VALVES

www.gemels.it

(POM seal) GN SW PN

		CARBON STEEL	STAINLESS STEEL
DN	PN	ITEM CODE	ITEM CODE
6	500	GN2TTT15024A000	GN2TTT15044A000
10	500	GN2TTT25024A000	GN2TTT25044A000
13	500	GN2TTT35024A000	GN2TTT35044A000
20	400	GN2TTT44024A000	GN2TTT44044A000
25	350	GN2TTT53024A000	GN2TTT53044A000
32	350	GN2TTT63024A000	GN2TTT63044A000
40	350	GN2TTT73024A000	GN2TTT73044A000
50	350	GN2TTT83024A000	GN2TTT83044A000

(POM seal) GN SW S6000

		CARBON STEEL	STAINLESS STEEL
DN	PN	ITEM CODE	ITEM CODE
6	S6000	GN2TTT1G024A000	GN2TTT1G044A000
10	S6000	GN2TTT2G024A000	GN2TTT2G044A000
13	S6000	GN2TTT3G024A000	GN2TTT3G044A000
20	S6000	GN2TTT4G024A000	GN2TTT4G044A000
25	S6000	GN2TTT5G024A000	GN2TTT5G044A000
32	S6000	GN2TTT6G024A000	GN2TTT6G044A000
40	S6000	GN2TTT7G024A000	GN2TTT7G044A000
50	S6000	GN2TTT8G024A000	GN2TTT8G044A000

(PEEK seal) GN SW PN

		CARBON STEEL	STAINLESS STEEL
DN	PN	ITEM CODE	ITEM CODE
6	500	GN2TTT15024P000	GN2TTT15044P000
10	500	GN2TTT25024P000	GN2TTT25044P000
13	500	GN2TTT35024P000	GN2TTT35044P000
20	400	GN2TTT44024P000	GN2TTT44044P000
25	350	GN2TTT53024P000	GN2TTT53044P000
32	350	GN2TTT63024P000	GN2TTT63044P000
40	350	GN2TTT73024P000	GN2TTT73044P000
50	350	GN2TTT83024P000	GN2TTT83044P000

(PEEK seal) GN SW S6000

		CARBON STEEL	STAINLESS STEEL
DN	PN	ITEM CODE	ITEM CODE
6	S6000	GN2TTT1G024P000	GN2TTT1G044P000
10	S6000	GN2TTT2G024P000	GN2TTT2G044P000
13	S6000	GN2TTT3G024P000	GN2TTT3G044P000
20	S6000	GN2TTT4G024P000	GN2TTT4G044P000
25	S6000	GN2TTT5G024P000	GN2TTT5G044P000
32	S6000	GN2TTT6G024P000	GN2TTT6G044P000
40	S6000	GN2TTT7G024P000	GN2TTT7G044P000
50	S6000	GN2TTT8G024P000	GN2TTT8G044P000



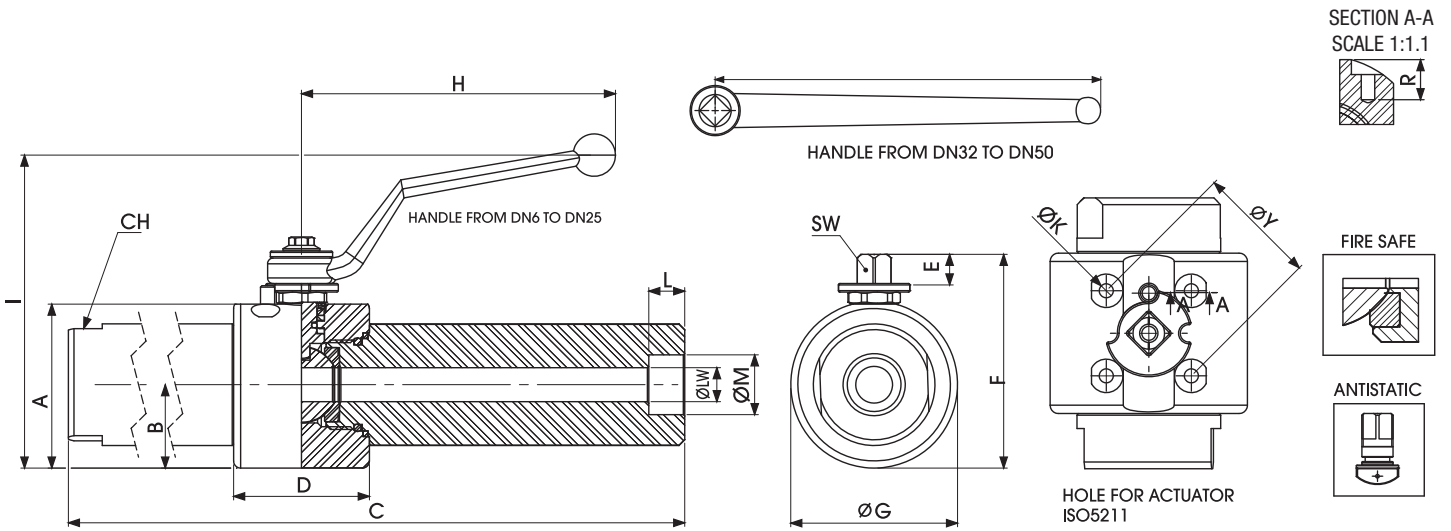

GN SW EXTRALONG

Standard

TYPE	DN	A	B	C	D	E	F	ØG	H	I	L	ØM	ØY	ØK	R	ISO 5211	CH	SW	ØLW	KG
GN SWXT 1/4	6	53	27	262	44	10,5	70	54	110	113	11,1	14,1	36	M5	12	F03	32	9	6	2,702
GN SWXT 3/8	10	53	27	262	44	10,5	70	54	110	113	11,1	17,53	36	M5	12	F03	32	9	10	2,599
GN SWXT 1/2	13	58	29,5	271	48	10,5	75,5	59	110	118	12,7	21,72	36	M5	12	F03	38	9	13	3,303
GN SWXT 3/4	20	72,5	37	288	62	14	95,5	74	180	128	15	27,05	50	M6	12	F05	48	14	20	5,595
GN SWXT 1	25	81	41,5	296	66	14	104	83	180	137	16	33,78	50	M6	12	F05	55	14	25	7,534
GN SWXT 1 1/4	32	96	49,5	318	83	14	118,5	99	300	128	17,5	42,7	70	M8	15	F07	65	17	32	11,123
GN SWXT 1 1/2	40	109,5	57	325	89	14	132,5	114	300	142	19	48,64	70	M8	15	F07	80	17	40	15,467
GN SWXT 2	50	118	61,5	350	101	14	141	123	300	150	22	61,2	70	M8	15	F07	90	17	50	19,178



2-WAY HIGH PRESSURE BALL VALVES

www.gemels.it

(POM seal) GN SW EXTRALONG PN

		CARBON STEEL	STAINLESS STEEL
DN	PN	ITEM CODE	ITEM CODE
6	500	GN2TXT15024A000	GN2TXT15044A000
10	500	GN2TXT25024A000	GN2TXT25044A000
13	500	GN2TXT35024A000	GN2TXT35044A000
20	400	GN2TXT44024A000	GN2TXT44044A000
25	350	GN2TXT53024A000	GN2TXT53044A000
32	350	GN2TXT63024A000	GN2TXT63044A000
40	350	GN2TXT73024A000	GN2TXT73044A000
50	350	GN2TXT83024A000	GN2TXT83044A000

(POM seal) GN SW EXTRALONG S6000

		CARBON STEEL	STAINLESS STEEL
DN	PN	ITEM CODE	ITEM CODE
6	S6000	GN2TXT1G024A000	GN2TXT1G044A000
10	S6000	GN2TXT2G024A000	GN2TXT2G044A000
13	S6000	GN2TXT3G024A000	GN2TXT3G044A000
20	S6000	GN2TXT4G024A000	GN2TXT4G044A000
25	S6000	GN2TXT5G024A000	GN2TXT5G044A000
32	S6000	GN2TXT6G024A000	GN2TXT6G044A000
40	S6000	GN2TXT7G024A000	GN2TXT7G044A000
50	S6000	GN2TXT8G024A000	GN2TXT8G044A000

(PEEK seal) GN SW EXTRALONG PN

		CARBON STEEL	STAINLESS STEEL
DN	PN	ITEM CODE	ITEM CODE
6	500	GN2TXT15024P000	GN2TXT15044P000
10	500	GN2TXT25024P000	GN2TXT25044P000
13	500	GN2TXT35024P000	GN2TXT35044P000
20	400	GN2TXT44024P000	GN2TXT44044P000
25	350	GN2TXT53024P000	GN2TXT53044P000
32	350	GN2TXT63024P000	GN2TXT63044P000
40	350	GN2TXT73024P000	GN2TXT73044P000
50	350	GN2TXT83024P000	GN2TXT83044P000

(PEEK seal) GN SW EXTRALONG S6000

		CARBON STEEL	STAINLESS STEEL
DN	PN	ITEM CODE	ITEM CODE
6	S6000	GN2TXT1G024P000	GN2TXT1G044P000
10	S6000	GN2TXT2G024P000	GN2TXT2G044P000
13	S6000	GN2TXT3G024P000	GN2TXT3G044P000
20	S6000	GN2TXT4G024P000	GN2TXT4G044P000
25	S6000	GN2TXT5G024P000	GN2TXT5G044P000
32	S6000	GN2TXT6G024P000	GN2TXT6G044P000
40	S6000	GN2TXT7G024P000	GN2TXT7G044P000
50	S6000	GN2TXT8G024P000	GN2TXT8G044P000





2-WAY HIGH PRESSURE BALL VALVES

Specialist in Ball Valves

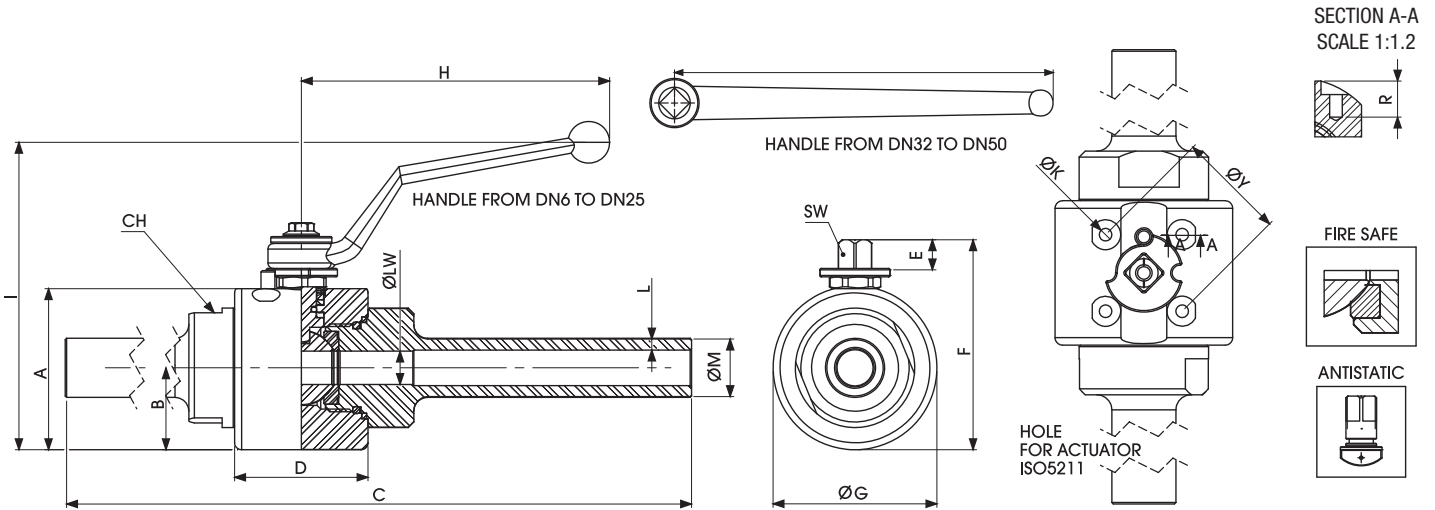

GN PE

Standard

TYPE	DN	A	B	C	D	E	F	ØG	H	I	LSCH80	ØM	ØY	ØK	R	ISO 5211	CH	SW	ØLW	KG
GN PE 1/4	6	53	27	272	44	10,5	70	54	110	113	3,02	13,7	36	M5	12	F03	32	9	6	1,227
GN PE 3/8	10	53	27	272	44	10,5	70	54	110	113	3,2	17,1	36	M5	12	F03	32	9	10	1,27
GN PE 1/2	13	58	29,5	281	48	10,5	75,5	59	110	118	3,73	21,3	36	M5	12	F03	38	9	13	1,709
GN PE 3/4	20	72,5	37	298	62	14	95,5	74	180	128	3,91	26,7	50	M6	12	F05	48	14	20	3,159
GN PE 1	25	81	41,5	306	66	14	104	83	180	137	4,55	33,4	50	M6	12	F05	55	14	25	4,224
GN PE 1 1/4	32	96	49,5	327	83	14	118,5	99	300	128	4,85	42,2	70	M8	15	F07	65	17	32	6,951
GN PE 1 1/2	40	109,5	57	335	89	14	132,5	114	300	142	5,08	48,3	70	M8	15	F07	80	17	40	9,283
GN PE 2	50	118	61,5	360	101	14	141	123	300	150	5,54	60,3	70	M8	15	F07	90	17	50	12,252

"The company reserves the right to operate dimensional changes without prior notice".



2-WAY HIGH PRESSURE BALL VALVES

www.gemels.it

(POM seal) GN PE PN

		CARBON STEEL	STAINLESS STEEL
DN	PN	ITEM CODE	ITEM CODE
6	500	GN2BWT15024A000	GN2BWT15044A000
10	500	GN2BWT25024A000	GN2BWT25044A000
13	500	GN2BWT35024A000	GN2BWT35044A000
20	400	GN2BWT44024A000	GN2BWT44044A000
25	350	GN2BWT53024A000	GN2BWT53044A000
32	350	GN2BWT63024A000	GN2BWT63044A000
40	350	GN2BWT73024A000	GN2BWT73044A000
50	350	GN2BWT83024A000	GN2BWT83044A000

(POM seal) GN PE S6000

		CARBON STEEL	STAINLESS STEEL
DN	PN	ITEM CODE	ITEM CODE
6	S6000	GN2BWT1G024A000	GN2BWT1G044A000
10	S6000	GN2BWT2G024A000	GN2BWT2G044A000
13	S6000	GN2BWT3G024A000	GN2BWT3G044A000
20	S6000	GN2BWT4G024A000	GN2BWT4G044A000
25	S6000	GN2BWT5G024A000	GN2BWT5G044A000
32	S6000	GN2BWT6G024A000	GN2BWT6G044A000
40	S6000	GN2BWT7G024A000	GN2BWT7G044A000
50	S6000	GN2BWT8G024A000	GN2BWT8G044A000

(PEEK seal) GN PE PN

		CARBON STEEL	STAINLESS STEEL
DN	PN	ITEM CODE	ITEM CODE
6	500	GN2BWT15024P000	GN2BWT15044P000
10	500	GN2BWT25024P000	GN2BWT25044P000
13	500	GN2BWT35024P000	GN2BWT35044P000
20	400	GN2BWT44024P000	GN2BWT44044P000
25	350	GN2BWT53024P000	GN2BWT53044P000
32	350	GN2BWT63024P000	GN2BWT63044P000
40	350	GN2BWT73024P000	GN2BWT73044P000
50	350	GN2BWT83024P000	GN2BWT83044P000

(PEEK seal) GN PE S6000

		CARBON STEEL	STAINLESS STEEL
DN	PN	ITEM CODE	ITEM CODE
6	S6000	GN2BWT1G024P000	GN2BWT1G044P000
10	S6000	GN2BWT2G024P000	GN2BWT2G044P000
13	S6000	GN2BWT3G024P000	GN2BWT3G044P000
20	S6000	GN2BWT4G024P000	GN2BWT4G044P000
25	S6000	GN2BWT5G024P000	GN2BWT5G044P000
32	S6000	GN2BWT6G024P000	GN2BWT6G044P000
40	S6000	GN2BWT7G024P000	GN2BWT7G044P000
50	S6000	GN2BWT8G024P000	GN2BWT8G044P000



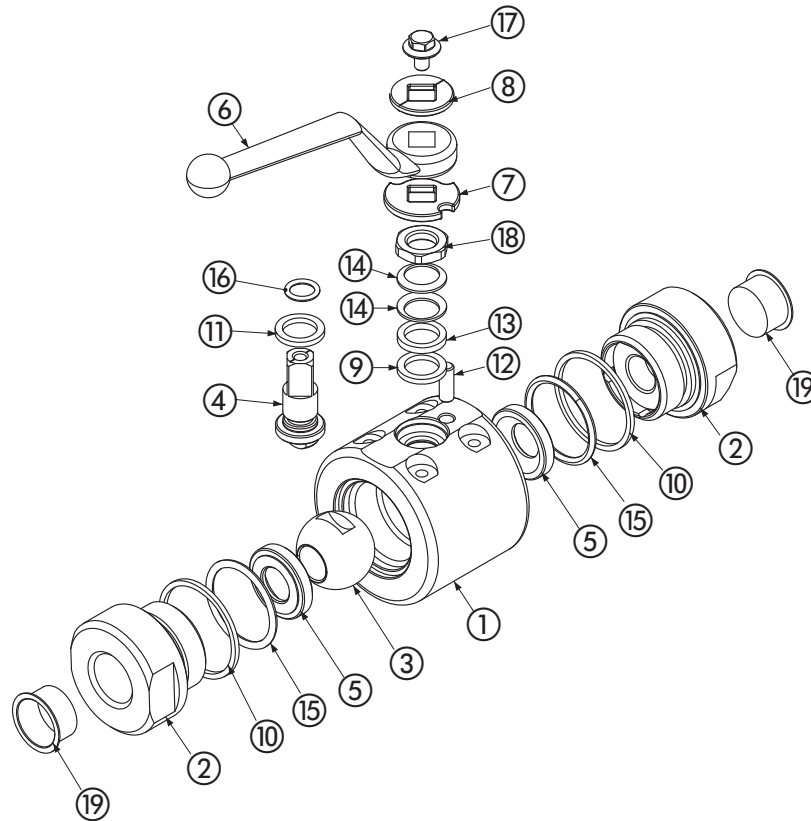

Carbon steel

Pos	Description	Material	Q.tà
1	Body	1,0570	1
2	Adapter	1,0570	2
3	Ball	1,4404	1
4	Stem	1,4404	1
5	Ball seat	POM	2
6	Handle	1,0116	1
7	Washer	1,4301	1
8	Washer	1,4301	1
9	Body ring	GRAPHITE	1
10	Adapter ring	GRAPHITE	2
11	Stem ring	PTFE	2
12	Spine	1,4301	1
13	Press ring	1,4301	1
14	Spring	1,4301	2
15	Adapter o-ring	NBR	2
16	Stem o-ring	NBR	1
17	Screw	DIN6921 A2	1
18	Nut	1,4301	1
19	Caps	PVC	2

On request

- Reduced bore
- O-Ring in FKM, EPDM, HNBR, KALREZ
- Seals in PTFE, PEEK, PA612, GEMPTFE, METAL TO METAL
- Special threads
- Pressure class up to PN500 or 6000 Psi
- Locking device
- Pneumatic and electrical actuator

Stainless steel

Pos	Description	Material	Q.tà
1	Body	1,4404	1
2	Adapter	1,4404	2
3	Ball	1,4404	1
4	Stem	1,4404	1
5	Ball seat	POM	2
6	Handle	1,0116	1
7	Washer	1,4301	1
8	Washer	1,4301	1
9	Body ring	GRAPHITE	1
10	Adapter ring	GRAPHITE	2
11	Stem ring	PTFE	2
12	Spine	1,4301	1
13	Press ring	1,4301	1
14	Spring	1,4301	2
15	Adapter o-ring	NBR	2
16	Stem o-ring	NBR	1
17	Screw	DIN6921 A2	1
18	Nut	1,4301	1
19	Caps	PVC	2

On request

- Reduced bore
- O-Ring in FKM, EPDM, HNBR, KALREZ
- Seals in PTFE, PEEK, PA612, GEMPTFE, METAL TO METAL
- Special threads
- Pressure class up to PN500 or 6000 Psi
- Locking device
- Pneumatic and electrical actuator

For further special requests please consult our technical/commercial service

+ SBF

2-WAY HIGH PRESSURE BALL VALVES

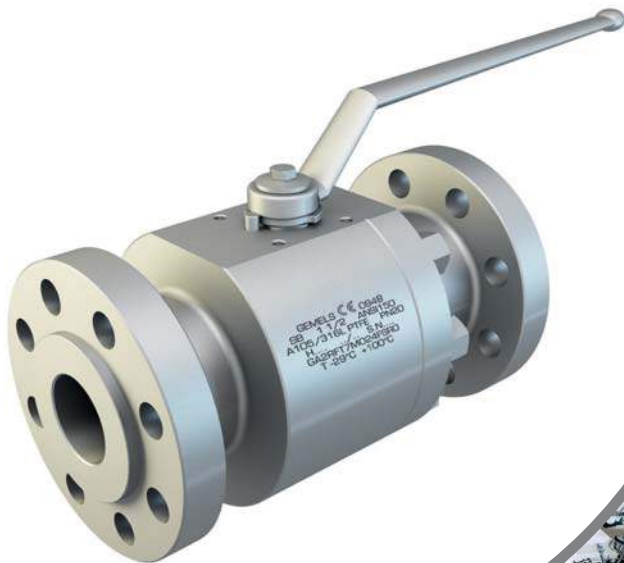

CARBON STEEL

- Type: ball valve SBF ANSI B16.5
- Body: round
- Material: A105/F316
- Ball seats: from DN13 up to DN150
- O-Rings: NBR, FKM, EPDM, MVQ
- Operating pressure: 20 Bar - 50 Bar - 100 Bar
150 Bar - 250 Bar - 420 Bar
- Antistatic device
- Fire safe BS 6755

SBF ANSI600 2" DN50 FB A105 F316 RPTFE NBR RF

Type and way of valve	Valves dimension of pressure (lbs)	Inch	Nominal dimension from DN13 up to DN150	Bore	Body material	Stem material	Ball seat material	Adapter and stem seal material	Flanged
SBF	ANSI2500	from 1/2 up to 6	up to DN150	FB	A105	A105	RPTFE	NBR	RF
Split body	ANSI1500			full bore	LF2	LF2	PEEK	FKM	RTJ
floating	ANSI900			RB		F316	NYLON	EPDM	BW
bolted body	ANSI600			reduce bore		F51	DEVLON	MVQ	FF
	ANSI300					F304	MET-TO-MET		
	ANSI150								

STAINLESS STEEL

- Type: ball valve SBF ANSI B16.5
- Body: round
- Material: F316/F51
- Ball seats: from DN13 up to DN150
- O-Rings: NBR, FKM, EPDM, MVQ
- Operating pressure: 20 Bar - 50 Bar - 100 Bar
150 Bar - 250 Bar - 420 Bar
- Antistatic device
- Fire safe BS 6755

SBF ANSI600 2" DN50 FB F316 F51 RPTFE NBR RF

Type and way of valve	Valves dimension of pressure (lbs)	Inch	Nominal dimension from DN13 up to DN150	Bore	Body material	Stem material	Ball seat material	Adapter and stem seal material	Flanged
SBF	ANSI2500	from 1/2 up to 6	up to DN150	FB	F316	A105	RPTFE	NBR	RF
Split body	ANSI1500			full bore	F51	F316	PEEK	FKM	RTJ
floating	ANSI900			RB	F304	F51	NYLON	EPDM	BW
bolted body	ANSI600			reduce bore		F304	DEVLON	MVQ	FF
	ANSI300						MET-TO-MET		
	ANSI150								

SBF

+ SBF150 2-WAY HIGH PRESSURE BALL VALVES

Specialist in Ball Valves

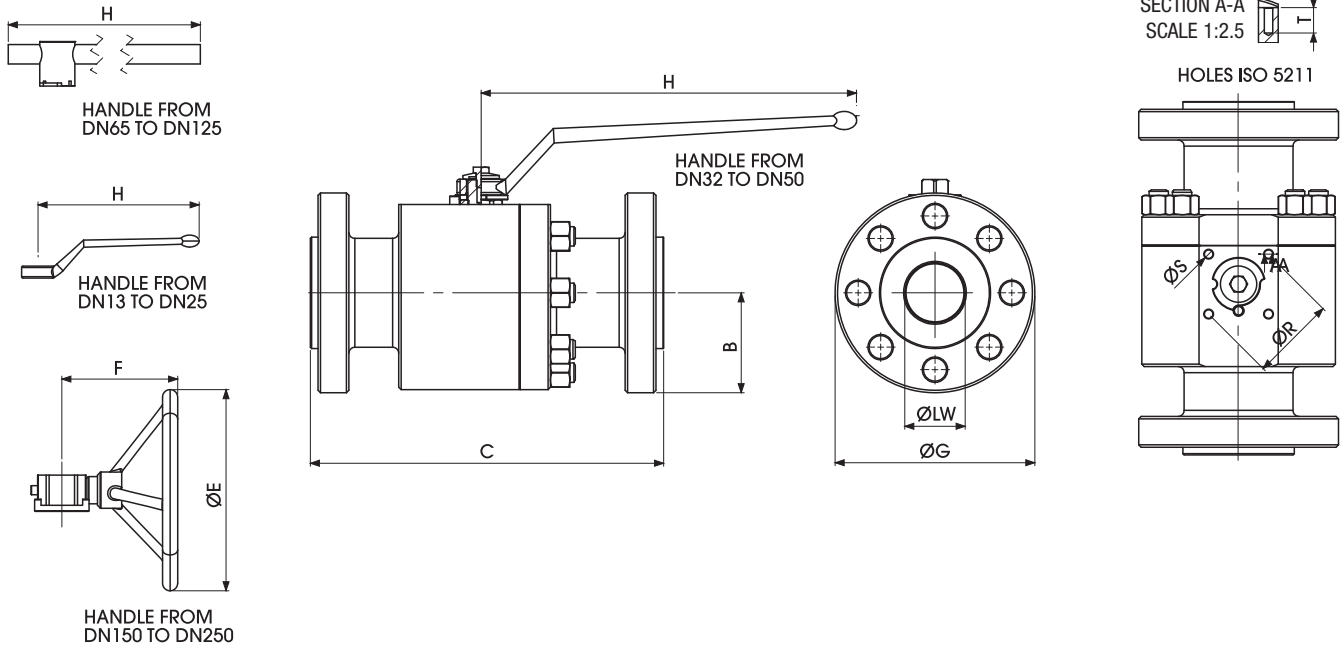

SPLIT BODY ANSI150 PN20 FULL BORE

COMPONENTS	MATERIAL	MIN/MAX TEMP. (°C)
BODY AND FLANGE	ASTM A105	-20°+120°
	ASTM A105N	-29°+120°
	ASTM A182 F316	-60°+230°
	ASTM A350 LF2	-40°+100°
STEM	ASTM A479 Tp316	-60°+230°
BALL	ASTM A182 F316	-60°+230°
STEM SEALS	PTFE	-196°+230°
	GRAPHITE	-
BALL SEATS	RPTFE	-196°+230°
	PEEK	-50°+250°
	NYLON	-40°+90°
	DEVLON	-40°+150°
	METAL-TO-METAL	-60°+230°
O-RING	NBR	-30°+100°
	FKM	-40°+200°
	EPDM	-50°+150°
	MVQ	-50°+150°
STUD/NUT	ASTM A193 B7/Gr. 2H	
	ASTM A193 B8/Gr. 8	
	ASTM A320 L7/Gr. 7	

PROVISIONS
API-6D ANSI B16.34 Specification for pipeline valves
API 598 Valve inspection and test
ANSI B.16.34 Steel valves Flanged and butt welding ends
ANSI B16.5 Steel pipe flanges and flanged fittings
ANSI B16.10 Face to face and end to end dimensions of ferrous valves
ASTM American society for testing materials
BS 6755 Testing of valves
NACE MR-01-75 Sulfide stress cracking resistant metallic materials for oil field equipment
UNI EN ISO 9001 quality system
DIN/ISO 5211 for mounting
BS-5351 steel ball valves for the petroleum, petrochemical and allied industries

+ SBF150 2-WAY HIGH PRESSURE BALL VALVES

www.gemels.it

SBF 150 FB

Standard

TYPE	PN	INCH	ØLW	B	C RF	C RTJ	ØG	H	ØR	ØS	ISO5211
SBF150	2 Mpa	1/2	13	44,5	108	119	89	111	36	M5	F03
SBF150	2 Mpa	3/4	20	49,25	117	130	98,5	200	42	M5	F04
SBF150	2 Mpa	1	25	54	127	140	108	200	50	M6	F04
SBF150	2 Mpa	1 1/4	32	58,75	140	153	117,5	200	50	M6	F05
SBF150	2 Mpa	1 1/2	40	63,5	165	178	127	300	50	M6	F05
SBF150	2 Mpa	2	49	75	178	191	150	300	50	M6	F05
SBF150	2 Mpa	2 1/2	63	89	191	203	178	600	70	M8	F10
SBF150	2 Mpa	3	74	95	203	216	190	650	70	M8	F10
SBF150	2 Mpa	4	100	115	229	242	230	650	102	M10	F10
SBF150	2 Mpa	6	150	139,8	394	407	279,5	-	125	M12	F12

SBF 150 RB

Standard

TYPE	PN	INCH	ØLW	B	C RF	C RTJ	ØG	H	ØR	ØS	ISO5211
SBF150	2 Mpa	3/4 x 1/2	13	49,25	117	130	98,5	111	36	M5	F03
SBF150	2 Mpa	1 x 3/4	20	54	127	140	108	200	42	M5	F04
SBF150	2 Mpa	1 1/4 x 1	25	58,75	140	153	117,5	200	42	M5	F04
SBF150	2 Mpa	1 1/2 x 1 1/4	32	63,5	165	178	127	200	42	M6	F05
SBF150	2 Mpa	2 x 1 1/2	40	75	178	191	150	300	50	M6	F05
SBF150	2 Mpa	2 1/2 x 2	49	89	191	203	178	300	50	M6	F10
SBF150	2 Mpa	3 x 2 1/2	63	95	203	216	190	300	50	M6	F10
SBF150	2 Mpa	4 x 3	74	114,5	229	242	229	600	102	M10	F10
SBF150	2 Mpa	6 x 4	100	139,8	394	407	279,5	-	125	M12	F12
SBF150	2 Mpa	8 x 6	150	171,5	457	470	343	-	125	M12	F12

SBF

+ SBF300 2-WAY HIGH PRESSURE BALL VALVES

Specialist in Ball Valves

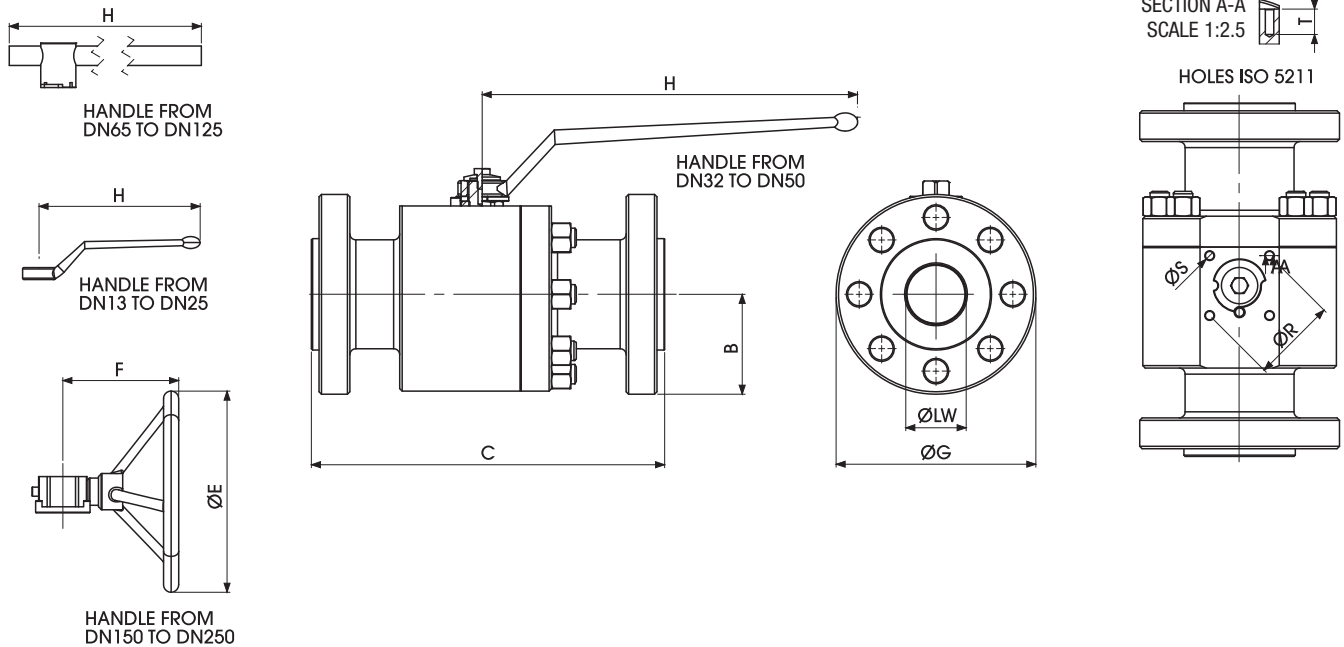

SPLIT BODY ANSI300 PN50 FULL BORE

COMPONENTS	MATERIAL	MIN/MAX TEMP. (°C)
BODY AND FLANGE	ASTM A105	-20°+120°
	ASTM A105N	-29°+120°
	ASTM A182 F316	-60°+230°
	ASTM A350 LF2	-40°+100°
STEM	ASTM A479 Tp316	-60°+230°
BALL	ASTM A182 F316	-60°+230°
STEM SEALS	PTFE	-196°+230°
	GRAPHITE	-
BALL SEATS	RPTFE	-196°+230°
	PEEK	-50°+250°
	NYLON	-40°+90°
	DEVLON	-40°+150°
	METAL-TO-METAL	-60°+230°
O-RING	NBR	-30°+100°
	FKM	-40°+200°
	EPDM	-50°+150°
	MVQ	-50°+150°
STUD/NUT	ASTM A193 B7/Gr. 2H	
	ASTM A193 B8/Gr. 8	
	ASTM A320 L7/Gr. 7	

PROVISIONS

API-6D ANSI B16.34 Specification for pipeline valves
 API 598 Valve inspection and test
 ANSI B.16.34 Steel valves Flanged and butt welding ends
 ANSI B16.5 Steel pipe flanges and flanged fittings
 ANSI B16.10 Face to face and end to end dimensions of ferrous valves
 ASTM American society for testing materials
 BS 6755 Testing of valves
 NACE MR-01-75 Sulfide stress cracking resistant mettalic materials for oil field equipment
 UNI EN ISO 9001 quality system
 DIN/ISO 5211 for mounting
 BS-5351 steel ball valves for the petroleum, petrochemical and allied industries

+ SBF300 2-WAY HIGH PRESSURE BALL VALVES

www.gemels.it

SBF 300 FB

Standard

TYPE	PN	INCH	ØLW	B	C RF	C RTJ	ØG	H	ØR	ØS	ISO5211
SBF300	5 Mpa	1/2	13	47,6	140	151	95,2	111	36	M5	F03
SBF300	5 Mpa	3/4	20	58,75	152	165	117,5	120	50	M5	F04
SBF300	5 Mpa	1	25	62	165	178	123,8	200	50	M6	F04
SBF300	5 Mpa	1 1/4	32	66,15	178	191	133,3	300	50	M6	F04
SBF300	5 Mpa	1 1/2	40	77,8	191	203	155,6	300	50	M6	F05
SBF300	5 Mpa	2	49	82,5	216	232	165	300	50	M6	F05
SBF300	5 Mpa	2 1/2	63	95,25	241	257	190,5	600	70	M8	F10
SBF300	5 Mpa	3	74	105	283	299	210	650	70	M8	F10
SBF300	5 Mpa	4	100	127	305	321	254	600	102	M10	F10
SBF300	5 Mpa	6	150	158,8	403	419	317,5	-	125	M12	F12

SBF 300 RB

Standard

TYPE	PN	INCH	ØLW	B	C RF	C RTJ	ØG	H	ØR	ØS	ISO5211
SBF300	5 Mpa	3/4x1/2	13	58,75	152	165	117,5	111	36	M5	F03
SBF300	5 Mpa	1x3/4	20	62	165	178	123,8	120	50	M5	F04
SBF300	5 Mpa	1 1/4x1	25	66,15	178	191	133,3	300	50	M6	F04
SBF300	5 Mpa	1 1/2x1 1/4	32	77,8	191	203	155,6	300	50	M6	F05
SBF300	5 Mpa	2x1 1/2	40	82,5	216	232	165	300	50	M6	F05
SBF300	5 Mpa	2 1/2x2	49	95,25	241	257	190,5	600	50	M6	F10
SBF300	5 Mpa	3x2 1/2	63	104,75	283	299	209,5	600	70	M8	F10
SBF300	5 Mpa	4x3	74	127	305	321	254	600	70	M8	F10
SBF300	5 Mpa	6x4	100	158,8	403	419	317,5	-	102	M10	F12
SBF300	5 Mpa	8x6	150	190,5	502	518	381	-	125	M12	F12

SBF

+ SBF600 2-WAY HIGH PRESSURE BALL VALVES

Specialist in Ball Valves

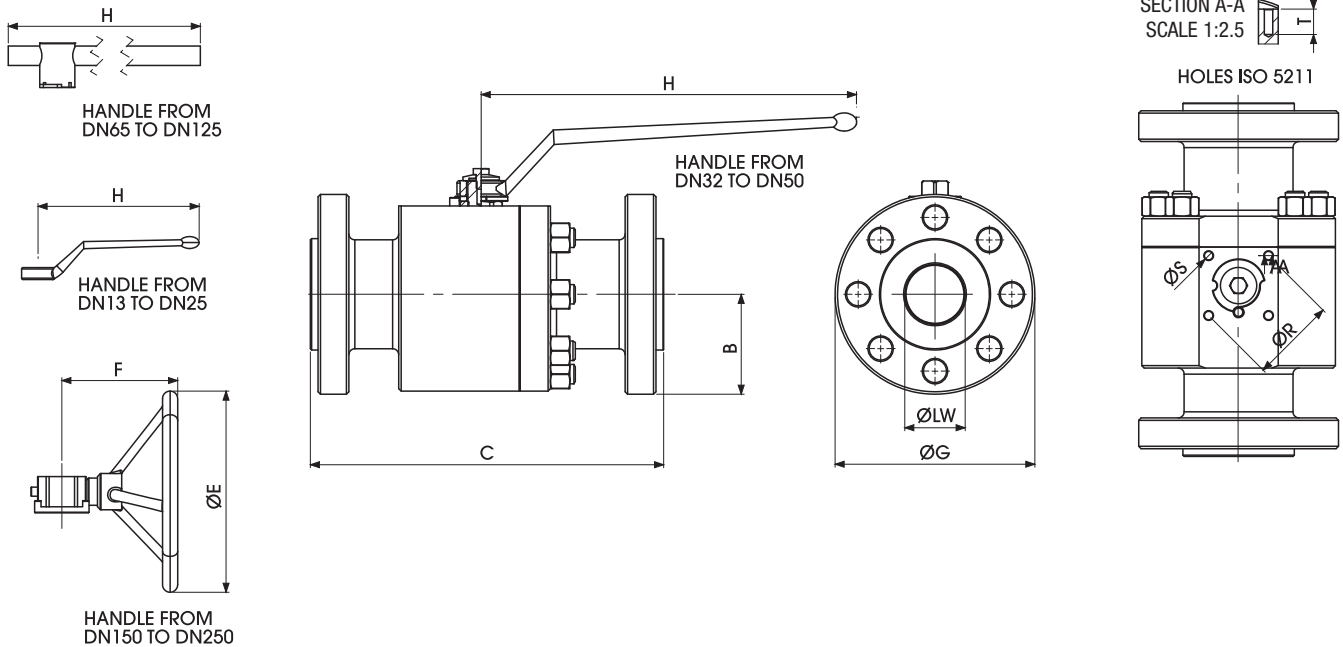

SPLIT BODY ANSI600 PN100 FULL BORE

COMPONENTS	MATERIAL	MIN/MAX TEMP. (°C)
BODY AND FLANGE	ASTM A105	-20°+120°
	ASTM A105N	-29°+120°
	ASTM A182 F316	-60°+230°
	ASTM A350 LF2	-40°+100°
STEM	ASTM A479 Tp316	-60°+230°
BALL	ASTM A182 F316	-60°+230°
STEM SEALS	PTFE	-196°+230°
	GRAPHITE	-
BALL SEATS	RPTFE	-196°+230°
	PEEK	-50°+250°
	NYLON	-40°+90°
	DEVLON	-40°+150°
	METAL-TO-METAL	-60°+230°
O-RING	NBR	-30°+100°
	FKM	-40°+200°
	EPDM	-50°+150°
	MVQ	-50°+150°
STUD/NUT	ASTM A193 B7/Gr. 2H	
	ASTM A193 B8/Gr. 8	
	ASTM A320 L7/Gr. 7	

PROVISIONS

API-6D ANSI B16.34 Specification for pipeline valves
 API 598 Valve inspection and test
 ANSI B.16.34 Steel valves Flanged and butt welding ends
 ANSI B16.5 Steel pipe flanges and flanged fittings
 ANSI B16.10 Face to face and end to end dimensions of ferrous valves
 ASTM American society for testing materials
 BS 6755 Testing of valves
 NACE MR-01-75 Sulfide stress cracking resistant mettalic materials for oil field equipment
 UNI EN ISO 9001 quality system
 DIN/ISO 5211 for mounting
 BS-5351 steel ball valves for the petroleum, petrochemical and allied industries

+ SBF600 2-WAY HIGH PRESSURE BALL VALVES

www.gemels.it

SBF 600 FB

Standard

TYPE	PN	INCH	ØLW	B	C RF	C RTJ	ØG	H	ØR	ØS	ISO5211
SBF600	10 Mpa	1/2	13	47,6	165	163,5	95,25	111	36	M5	F03
SBF600	10 Mpa	3/4	20	58,75	190	190,5	117,5	200	50	M5	F04
SBF600	10 Mpa	1	25	62	216	216	124	200	50	M6	F05
SBF600	10 Mpa	1 1/4	32	66,75	228,5	228,5	133,5	300	50	M6	F05
SBF600	10 Mpa	1 1/2	40	77,75	241	241	155,5	300	50	M6	F05
SBF600	10 Mpa	2	49	82,5	292	295,3	165	300	70	M8	F05
SBF600	10 Mpa	2 1/2	63	95,25	330	333	190,5	600	70	M8	F10
SBF600	10 Mpa	3	74	105	356	359	210	650	70	M8	F10
SBF600	10 Mpa	4	100	136,5	432	435	273	650	102	M10	F10

SBF 600 RB

Standard

TYPE	PN	INCH	ØLW	B	C RF	C RTJ	ØG	H	ØR	ØS	ISO5211
SBF600	10 Mpa	3/4x1/2	13	58,75	190	190,5	117,5	111	36	M5	F03
SBF600	10 Mpa	1x3/4	20	62	216	216	124	120	50	M5	F04
SBF600	10 Mpa	1 1/4x1	25	66,75	228,5	228,5	133,5	300	50	M6	F05
SBF600	10 Mpa	1 1/2x1 1/4	32	77,75	241	241	155,5	300	50	M6	F05
SBF600	10 Mpa	2x1 1/2	40	82,5	292	295,3	165	300	50	M6	F05
SBF600	10 Mpa	2 1/2x2	49	95,25	330	333	190,5	600	70	M8	F10
SBF600	10 Mpa	3x2 1/2	63	104,75	356	359	209,5	600	70	M8	F10
SBF600	10 Mpa	4x3	74	136,5	432	435	273	600	70	M8	F10
SBF600	10 Mpa	6x4	100	177,5	559	562	355,5	-	102	M10	F12

SBF

+ SBF900 2-WAY HIGH PRESSURE BALL VALVES

Specialist in Ball Valves

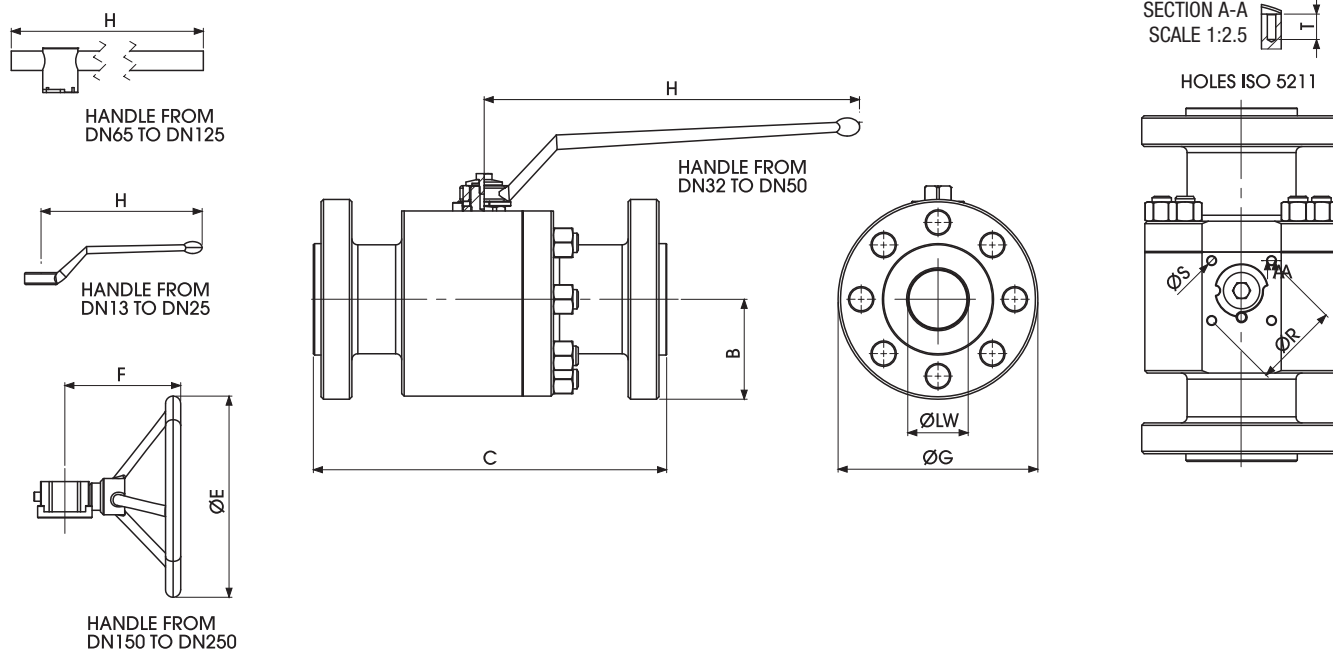

SPLIT BODY ANSI900 PN150 FULL BORE

COMPONENTS	MATERIAL	MIN/MAX TEMP. (°C)
BODY AND FLANGE	ASTM A105	-20°+120°
	ASTM A105N	-29°+120°
	ASTM A182 F316	-60°+230°
	ASTM A350 LF2	-40°+100°
STEM	ASTM A479 Tp316	-60°+230°
BALL	ASTM A182 F316	-60°+230°
STEM SEALS	PTFE	-196°+230°
	GRAPHITE	-
BALL SEATS	RPTFE	-196°+230°
	PEEK	-50°+250°
	NYLON	-40°+90°
	DEVLON	-40°+150°
	METAL-TO-METAL	-60°+230°
O-RING	NBR	-30°+100°
	FKM	-40°+200°
	EPDM	-50°+150°
	MVQ	-50°+150°
STUD/NUT	ASTM A193 B7/Gr. 2H	
	ASTM A193 B8/Gr. 8	
	ASTM A320 L7/Gr. 7	

PROVISIONS
API-6D ANSI B16.34 Specification for pipeline valves
API 598 Valve inspection and test
ANSI B.16.34 Steel valves Flanged and butt welding ends
ANSI B16.5 Steel pipe flanges and flanged fittings
ANSI B16.10 Face to face and end to end dimensions of ferrous valves
ASTM American society for testing materials
BS 6755 Testing of valves
NACE MR-01-75 Sulfide stress cracking resistant mettalic materials for oil field equipment
UNI EN ISO 9001 quality system
DIN/ISO 5211 for mounting
BS-5351 steel ball valves for the petroleum, petrochemical and allied industries

+ SBF900 2-WAY HIGH PRESSURE BALL VALVES

www.gemels.it

SBF 900 FB

Standard

TYPE	PN	INCH	ØLW	B	C RF	C RTJ	ØG	H	ØR	ØS	ISO5211
SBF 1500	25 Mpa	1/2	13	60,5	216	216	121	110	36	M5	F03
SBF 1500	25 Mpa	3/4	19	65	229	229	130	120	50	M6	F05
SBF 1500	25 Mpa	1	25	74,5	254	254	149	200	50	M6	F05
SBF 1500	25 Mpa	1 1/4	32	79,5	279	279	159	300	70	M8	F07
SBF 1500	25 Mpa	1 1/2	38	89	305	305	178	300	70	M8	F07
SBF 1500	25 Mpa	2	49	107,5	368	371	215	300	70	M8	F10

SBF 900 RB

Standard

TYPE	PN	INCH	ØLW	B	C RF	C RTJ	ØG	H	ØR	ØS	ISO5211
SBF 1500	25 Mpa	3/4x1/2	13	65	254	254	130	120	50	M6	F05
SBF 1500	25 Mpa	1x3/4	19	74,5	279	279	149	120	50	M6	F05
SBF 1500	25 Mpa	1 1/4x1	25	79,5	292	292	159	300	50	M6	F05
SBF 1500	25 Mpa	1 1/2x1 1/4	32	89	305	305	178	300	70	M8	F07
SBF 1500	25 Mpa	2x1 1/2	38	108	368	371	216	300	70	M8	F07
SBF 1500	25 Mpa	2 1/2x2	49	122	419	422	244	600	102	M10	F10

SBF

+ SBF1500

2-WAY HIGH PRESSURE BALL VALVES

Specialist in Ball Valves

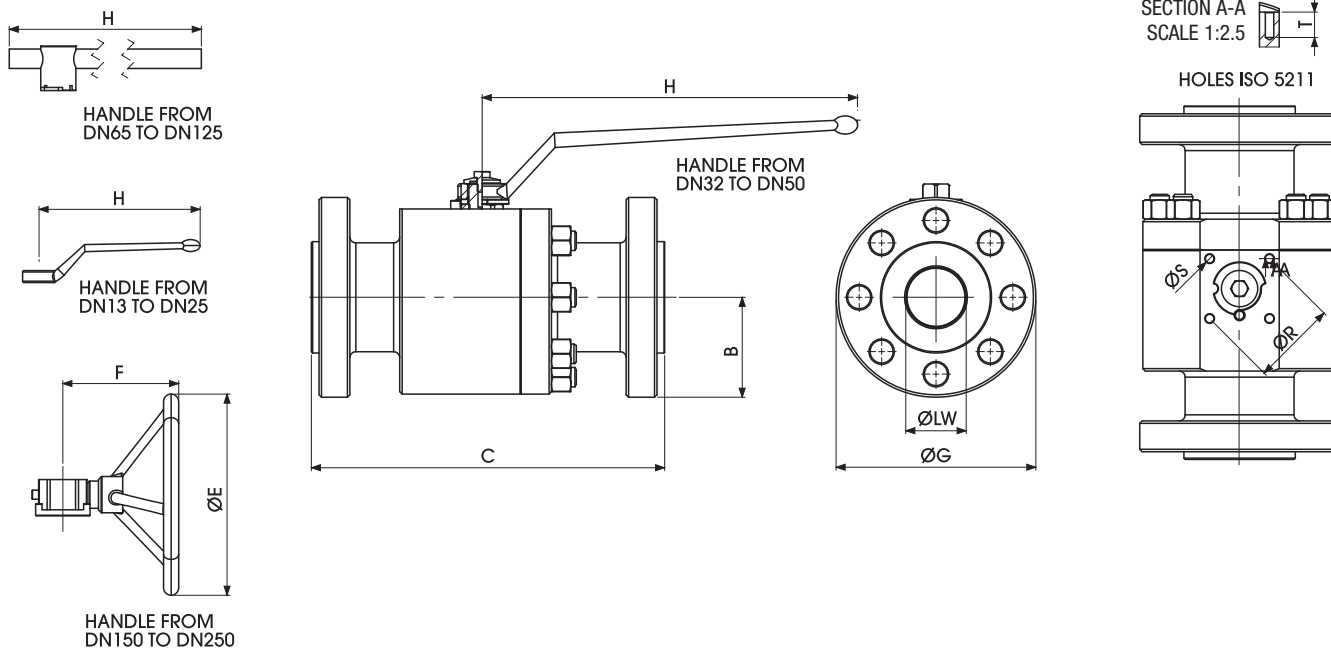

SPLIT BODY ANSI1500 PN250 FULL BORE

COMPONENTS	MATERIAL	MIN/MAX TEMP. (°C)
BODY AND FLANGE	ASTM A105	-20°+120°
	ASTM A105N	-29°+120°
	ASTM A182 F316	-60°+230°
	ASTM A350 LF2	-40°+100°
STEM	ASTM A479 Tp316	-60°+230°
BALL	ASTM A182 F316	-60°+230°
STEM SEALS	PTFE	-196°+230°
	GRAPHITE	-
BALL SEATS	RPTFE	-196°+230°
	PEEK	-50°+250°
	NYLON	-40°+90°
	DEVLON	-40°+150°
	METAL-TO-METAL	-60°+230°
O-RING	NBR	-30°+100°
	FKM	-40°+200°
	EPDM	-50°+150°
	MVQ	-50°+150°
STUD/NUT	ASTM A193 B7/Gr. 2H	
	ASTM A193 B8/Gr. 8	
	ASTM A320 L7/Gr. 7	

PROVISIONS
API-6D ANSI B16.34 Specification for pipeline valves
API 598 Valve inspection and test
ANSI B.16.34 Steel valves Flanged and butt welding ends
ANSI B16.5 Steel pipe flanges and flanged fittings
ANSI B16.10 Face to face and end to end dimensions of ferrous valves
ASTM American society for testing materials
BS 6755 Testing of valves
NACE MR-01-75 Sulfide stress cracking resistant mettalic materials for oil field equipment
UNI EN ISO 9001 quality system
DIN/ISO 5211 for mounting
BS-5351 steel ball valves for the petroleum, petrochemical and allied industries

+ SBF1500

2-WAY HIGH PRESSURE BALL VALVES

www.gemels.it

SBF 1500 FB

Standard

TYPE	PN	INCH	ØLW	B	C RF	C RTJ	ØG	H	ØR	ØS	ISO5211
SBF 1500	25 Mpa	1/2	13	60,5	216	216	121	110	36	M5	F03
SBF 1500	25 Mpa	3/4	19	65	229	229	130	120	50	M6	F05
SBF 1500	25 Mpa	1	25	74,5	254	254	149	200	50	M6	F05
SBF 1500	25 Mpa	1 1/4	32	79,5	279	279	159	300	70	M8	F07
SBF 1500	25 Mpa	1 1/2	38	89	305	305	178	300	70	M8	F07
SBF 1500	25 Mpa	2	49	107,5	368	371	215	300	70	M8	F10

SBF 1500 RB

Standard

TYPE	PN	INCH	ØLW	B	C RF	C RTJ	ØG	H	ØR	ØS	ISO5211
SBF 1500	25 Mpa	3/4x1/2	13	65	254	254	130	120	50	M6	F05
SBF 1500	25 Mpa	1x3/4	19	74,5	279	279	149	120	50	M6	F05
SBF 1500	25 Mpa	1 1/4x1	25	79,5	292	292	159	300	50	M6	F05
SBF 1500	25 Mpa	1 1/2x1 1/4	32	89	305	305	178	300	70	M8	F07
SBF 1500	25 Mpa	2x1 1/2	38	108	368	371	216	300	70	M8	F07
SBF 1500	25 Mpa	2 1/2x2	49	122	419	422	244	600	102	M10	F10

SBF

+ SBF2500

2-WAY HIGH PRESSURE BALL VALVES

Specialist in Ball Valves

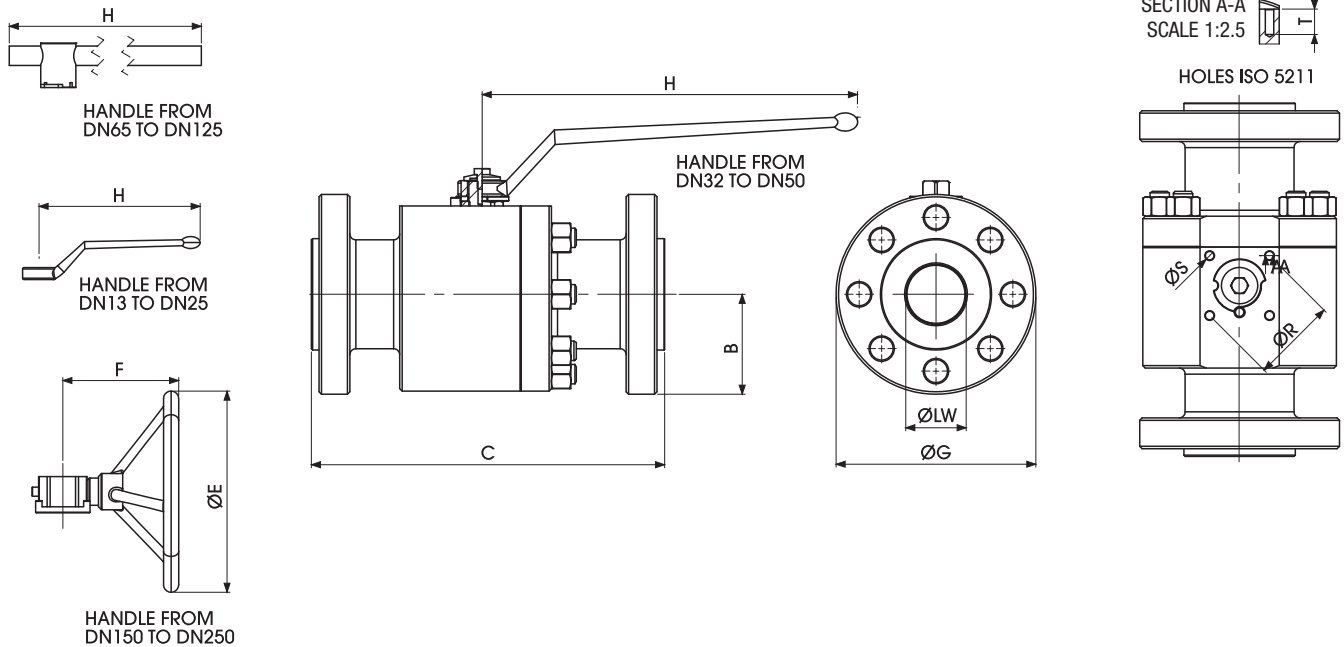

SPLIT BODY ANSI2500 PN420 FULL BORE

COMPONENTS	MATERIAL	MIN/MAX TEMP. (°C)
BODY AND FLANGE	ASTM A105	-20°+120°
	ASTM A105N	-29°+120°
	ASTM A182 F316	-60°+230°
	ASTM A350 LF2	-40°+100°
STEM	ASTM A479 Tp316	-60°+230°
BALL	ASTM A182 F316	-60°+230°
STEM SEALS	PTFE	-196°+230°
	GRAPHITE	-
BALL SEATS	RPTFE	-196°+230°
	PEEK	-50°+250°
	NYLON	-40°+90°
	DEVLON	-40°+150°
	METAL-TO-METAL	-60°+230°
O-RING	NBR	-30°+100°
	FKM	-40°+200°
	EPDM	-50°+150°
	MVQ	-50°+150°
STUD/NUT	ASTM A193 B7/Gr. 2H	
	ASTM A193 B8/Gr. 8	
	ASTM A320 L7/Gr. 7	

PROVISIONS

API-6D ANSI B16.34 Specification for pipeline valves
 API 598 Valve inspection and test
 ANSI B.16.34 Steel valves Flanged and butt welding ends
 ANSI B16.5 Steel pipe flanges and flanged fittings
 ANSI B16.10 Face to face and end to end dimensions of ferrous valves
 ASTM American society for testing materials
 BS 6755 Testing of valves
 NACE MR-01-75 Sulfide stress cracking resistant mettalic materials for oil field equipment
 UNI EN ISO 9001 quality system
 DIN/ISO 5211 for mounting
 BS-5351 steel ball valves for the petroleum, petrochemical and allied industries

+ SBF2500

2-WAY HIGH PRESSURE BALL VALVES

www.gemels.it

SBF 2500 FB

Standard

TYPE	PN	INCH	ØLW	B	C RF	C RTJ	ØG	H	R	S	ISO5211
SBF 2500	42 Mpa	1/2	13	66,5	264	264	133	110	36	M5	F03
SBF 2500	42 Mpa	3/4	19	70	273	273	140	120	50	M6	F05
SBF 2500	42 Mpa	1	25	79,5	308	308	159	120	50	M6	F05
SBF 2500	42 Mpa	1 1/4	32	92	356	356	184	300	70	M8	F07
SBF 2500	42 Mpa	1 1/2	38	101,5	387	387	203	300	70	M8	F07
SBF 2500	42 Mpa	2	42	117,5	451	454	235	300	102	M10	F10

SBF 2500 RB

Standard

TYPE	PN	INCH	ØLW	B	C RF	C RTJ	ØG	H	R	S	ISO5211
SBF 2500	42 Mpa	3/4 x 1/2	13	70	273	273	140	120	50	M6	F05
SBF 2500	42 Mpa	1 x 3/4	19	79,5	308	308	159	120	50	M6	F05
SBF 2500	42 Mpa	1 1/4 x 1	25	92	356	356	184	300	70	M8	F07
SBF 2500	42 Mpa	1 1/2 x 1 1/4	32	101,5	387	387	203	300	70	M8	F07
SBF 2500	42 Mpa	2 x 1 1/2	38	117,5	451	454	235	300	102	M10	F10
SBF 2500	42 Mpa	2 1/2 x 2	42	133,5	508	511	267	600	102	M10	F10

SBF

+ SBF 2-WAY HIGH PRESSURE BALL VALVES

Specialist in Ball Valves

2016 - Edition 1

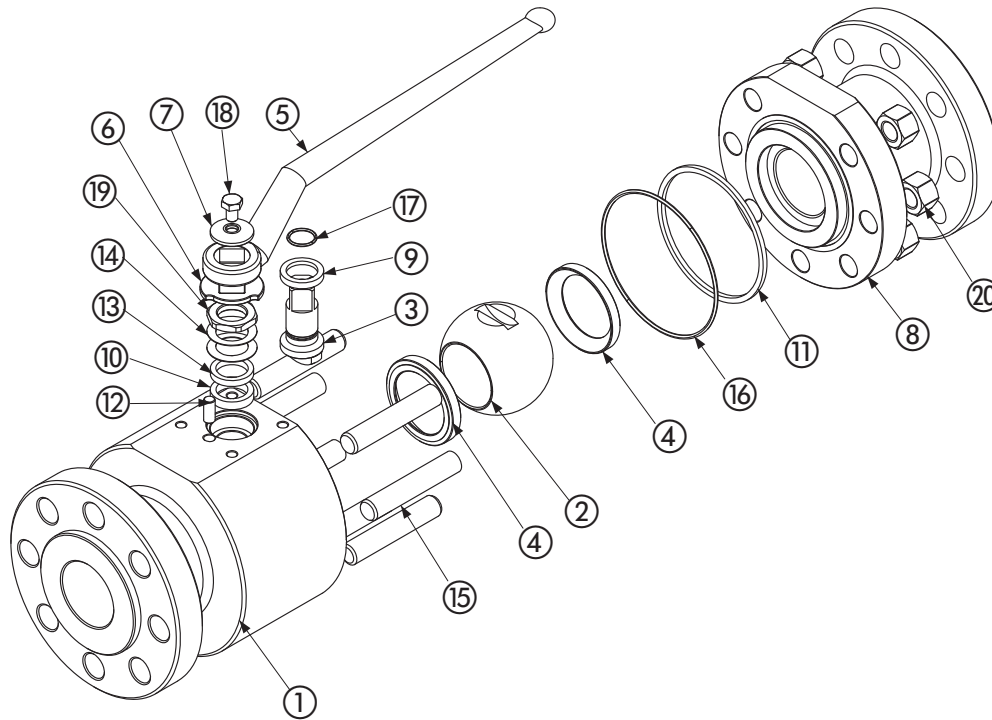

Carbon steel

Pos	Description	Material	Q.tà
1	Body	1,0570	1
2	Ball	1,4462	1
3	Stem	1,4462	1
4	Ball seat	PTFE	2
5	Handle	1,0116	1
6	Washer	1,4301	1
7	Washer	1,4301	1
8	Flange	1,0570	1
9	Stem ring	PTFE	1
10	Up ring	GRAPHITE	1
11	Flange ring	GRAPHITE	1
12	Spine	1,4301	1
13	Press ring	1,4301	1
14	Spring	1,4301	2
15	Bolts	ASTM A193 B7	8
16	Flange o-ring	NBR	1
17	Stem o-ring	NBR	1
18	Screw	DIN6921 A2	1
19	Nut	1,4301	1
20	Nut	ASTM A194 Gr. H2	8

Stainless steel

Pos	Description	Material	Q.tà
1	Body	1,4404	1
2	Ball	1,4462	1
3	Stem	1,4462	1
4	Ball seat	PTFE	2
5	Handle	1,4301	1
6	Washer	1,4301	1
7	Washer	1,4301	1
8	Flange	1,4404	1
9	Stem ring	PTFE	1
10	Up ring	GRAPHITE	1
11	Flange ring	GRAPHITE	1
12	Spine	1,4301	1
13	Press ring	1,4301	1
14	Spring	1,4301	2
15	Bolts	ASTM A193 B7	8
16	Flange o-ring	NBR	1
17	Stem o-ring	NBR	1
18	Screw	DIN6921 A2	1
19	Nut	1,4301	1
20	Nut	ASTM A194 Gr. H2	8

For further special requests please consult our technical/commercial service

On request

- Reduced bore
- O-Ring in FKM, EPDM, HNBR, KALREZ
- Seals in PTFE, PEEK, PA612, GEMPTFE, METAL TO METAL
- Pressure class ANSI 150-300-600 900-1500-2500
- Pneumatic and electrical actuator
- Locking device

On request

- Reduced bore
- O-Ring in FKM, EPDM, HNBR, KALREZ
- Seals in PTFE, PEEK, PA612, GEMPTFE, METAL TO METAL
- Pressure class ANSI 150-300-600 900-1500-2500
- Pneumatic and electrical actuator
- Locking device

+ SBT

2-WAY HIGH PRESSURE BALL VALVES



CARBON STEEL

- Type: ball valve SBT ANSI B16.5
- Body: forging
- Material: A105/F316
- Ball seats: from DN13 up to DN589
- O-Rings: NBR, FKM, EPDM, MVQ
- Operating pressure: 20 Bar - 50 Bar - 100 Bar
150 Bar - 250 Bar - 420 Bar
- Antistatic device
- Fire safe BS 6755

SBT ANSI600 2" DN50 FB A105 F316 RPTFE NBR RF

Type and way of valve	Valves dimension of pressure (lbs)	Inch	Nominal dimension from DN 13 up to DN 589	Bore	Body material	Stem material	Ball seat material	Adapter and stem seal material	Flanged
SBT	ANSI2500	from 1/2 up to 24	from DN 13 up to DN 589	FB	A105	A105	RPTFE	NBR	RF
Split body	ANSI1500			full bore	LF2	LF2	PEEK	FKM	RTJ
trunnion	ANSI900			RB		F316	NYLON	EPDM	BW
bolted body	ANSI600			reduce bore		F51	DEVLON	MVQ	FF
	ANSI300					F304	MET-TO-MET		
	ANSI150								

STAINLESS STEEL

- Type: ball valve SBT ANSI B16.5
- Body: forging
- Material: F316/F51
- Ball seats: from DN13 up to DN589
- O-Rings: NBR, FKM, EPDM, MVQ
- Operating pressure: 20 Bar - 50 Bar - 100 Bar
150 Bar - 250 Bar - 420 Bar
- Antistatic device
- Fire safe BS 6755

SBT ANSI600 2" DN50 FB F316 F51 RPTFE NBR RF

Type and way of valve	Valves dimension of pressure (lbs)	Inch	Nominal dimension from DN 13 up to DN 589	Bore	Body material	Stem material	Ball seat material	Adapter and stem seal material	Flanged
SBT	ANSI2500	from 1/2 up to 24	from DN 13 up to DN 589	FB	F316	A105	RPTFE	NBR	RF
Split body	ANSI1500			full bore	F51	F316	PEEK	FKM	RTJ
trunnion	ANSI900			RB	F304	F51	NYLON	EPDM	BW
bolted body	ANSI600			reduce bore		F304	DEVLON	MVQ	FF
	ANSI300						MET-TO-MET		
	ANSI150								

SBT

+ SBT150 2-WAY HIGH PRESSURE BALL VALVES

Specialist in Ball Valves

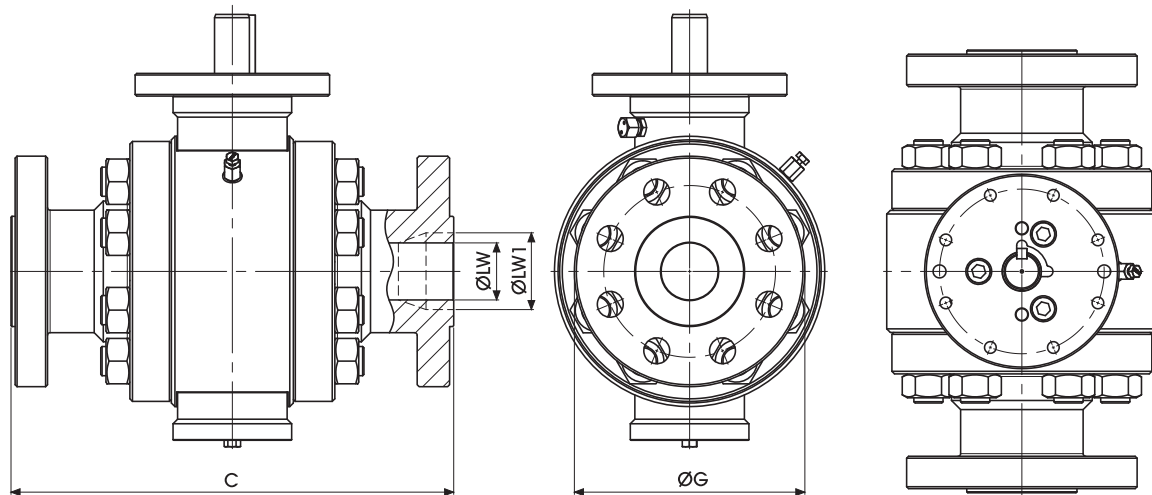

SBT 150 FB

Standard

TYPE	PN	INCH	LW	LW1	C RF	C RTJ	G
SBT A150	2 Mpa	2	49	-	178	191	152,5
SBT A150	2 Mpa	2 1/2	62	-	191	203	178
SBT A150	2 Mpa	3	74	-	203	216	190,5
SBT A150	2 Mpa	4	100	-	229	241	229

SBT 150 RB

Standard

TYPE	PN	INCH	LW	LW1	C RF	C RTJ	G
SBT A150	2 Mpa	2x1 1/2	38	49	178	191	152,5
SBT A150	2 Mpa	3x2 1/2	62	74	203	216	190,5
SBT A150	2 Mpa	3x2	49	100	229	241	229
SBT A150	2 Mpa	6x4	100	150	394	406	279,5

SPLIT BODY ANSI150 PN20 FULL AND REDUCED BORE

COMPONENTS	MATERIAL	MIN/MAX TEMP. (°C)
BODY AND FLANGE	ASTM A105	-20°+120°
	ASTM A105N	-29°+120°
	ASTM A182 F316	-60°+230°
	ASTM A350 LF2	-40°+100°
STEM	ASTM A479 Tp316	-60°+230°
BALL	ASTM A182 F316	-60°+230°
STEM SEALS	PTFE	-196°+230°
	GRAPHITE	-
BALL SEATS	RPTFE	-196°+230°
	PEEK	-50°+250°
	NYLON	-40°+90°
	DEVLON	-40°+150°
	METAL-TO-METAL	-60°+230°
O-RING	NBR	-30°+100°
	FKM	-40°+200°
	EPDM	-50°+150°
	MVQ	-50°+150°
STUD/NUT	ASTM A193 B7/Gr. 2H	
	ASTM A193 B8/Gr. 8	
	ASTM A320 L7/Gr. 7	

PROVISIONS

API-6D ANSI B16.34 Specification for pipeline valves
API 598 Valve inspection and test
ANSI B.16.34 Steel valves Flanged and butt welding ends
ANSI B16.5 Steel pipe flanges and flanged fittings
ANSI B16.10 Face to face and end to end dimensions of ferrous valves
ASTM American society for testing materials
BS 6755 Testing of valves
NACE MR-01-75 Sulfide stress cracking resistant metallic materials for oil field equipment
UNI EN ISO 9001 quality system
DIN/ISO 5211 for mounting

"The company reserves the right to operate dimensional changes without prior notice".

+ SBT150 2-WAY HIGH PRESSURE BALL VALVES

www.gemels.it

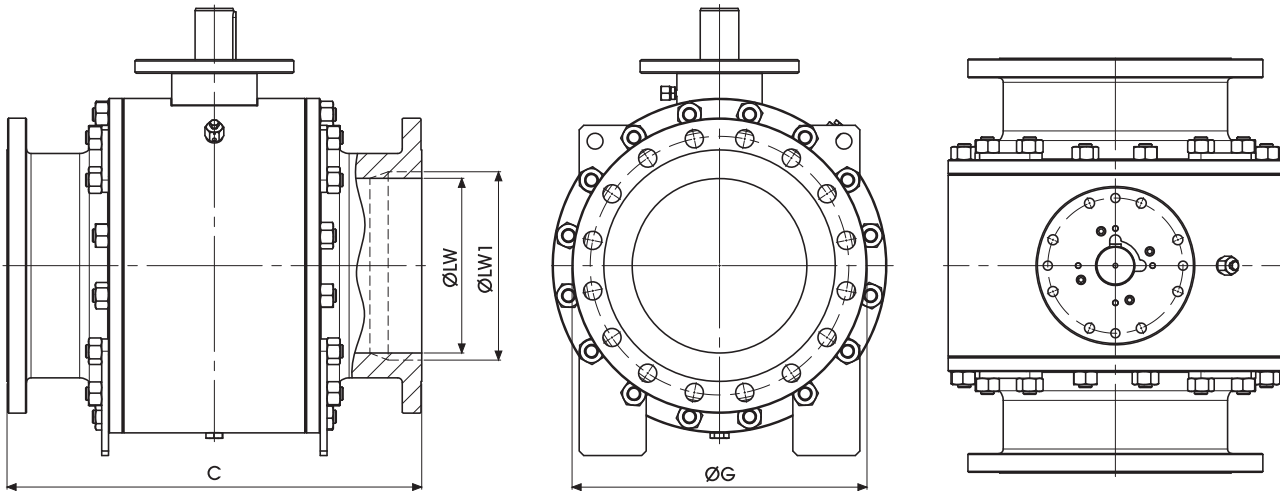

SBT 150 FB

Standard

TYPE	PN	INCH	LW	LW1	C RF	C RTJ	G
SBT A150	2 Mpa	6	150	-	394	406	279,5
SBT A150	2 Mpa	8	201	-	457	470	343
SBT A150	2 Mpa	10	252	-	533	546	406,5
SBT A150	2 Mpa	12	303	-	610	622	483
SBT A150	2 Mpa	14	334	-	689	699	533,5
SBT A150	2 Mpa	16	385	-	762	775	597
SBT A150	2 Mpa	18	436	-	864	876	635
SBT A150	2 Mpa	20	487	-	914	927	698,5
SBT A150	2 Mpa	22	538	-	-	-	750*
SBT A150	2 Mpa	24	589	-	1067	1080	813

SBT 150 RB

Standard

TYPE	PN	INCH	LW	LW1	C RF	C RTJ	G
SBT A150	2 Mpa	8x6	150	201	457	470	343
SBT A150	2 Mpa	10x8	201	252	533	546	406,5
SBT A150	2 Mpa	12x8	201	303	610	622	483
SBT A150	2 Mpa	14x10	252	334	689	699	533,5
SBT A150	2 Mpa	16x12	303	385	762	775	597
SBT A150	2 Mpa	18x14	334	436	864	876	635
SBT A150	2 Mpa	20x16	385	487	914	927	698,5
SBT A150	2 Mpa	24x20	487	589	1067	1080	813
SBT A150	2 Mpa	28x24	589	684	1245	-	925*
SBT A150	2 Mpa	30x24	589	735	1295	-	985*

* according to MSS SP44

SBT

+ SBT300 2-WAY HIGH PRESSURE BALL VALVES

Specialist in Ball Valves

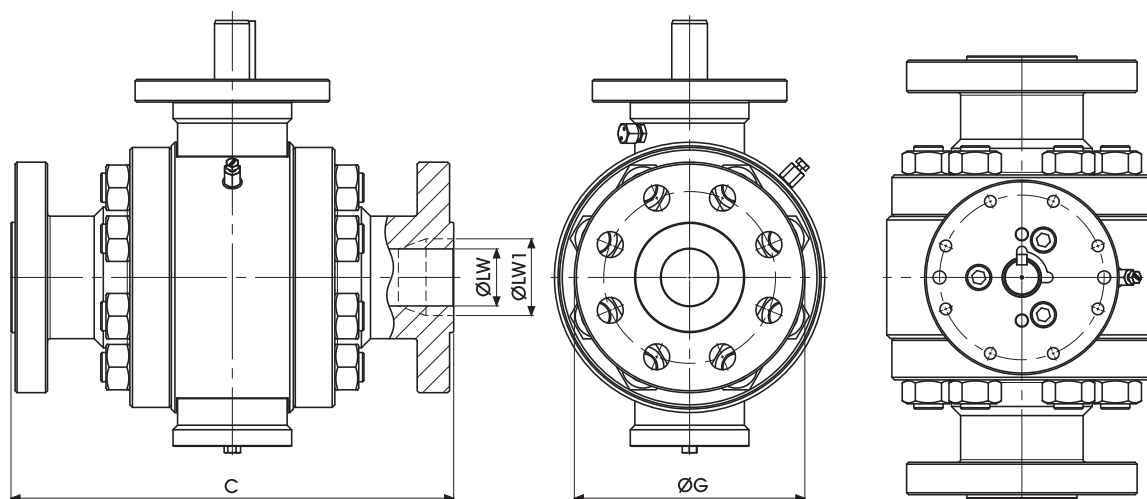

SBT 300 FB

Standard

TYPE	PN	INCH	LW	LW1	C RF	C RTJ	G
SBT A300	5 Mpa	2	49	-	216	232	165,5
SBT A300	5 Mpa	2 1/2	62	-	241	257	190,5
SBT A300	5 Mpa	3	74	-	283	298	210
SBT A300	5 Mpa	4	100	-	305	321	254

SBT 300 RB

Standard

TYPE	PN	INCH	LW	LW1	C RF	C RTJ	G
SBT A300	5 Mpa	2x1 1/2	38	49	216	232	165,5
SBT A300	5 Mpa	3x2 1/2	62	74	283	298	210
SBT A300	5 Mpa	3x2	49	100	305	321	254
SBT A300	5 Mpa	6x4	100	150	403	419	317,5

SPLIT BODY ANSI300 PN50 FULL AND REDUCED BORE

COMPONENTS	MATERIAL	MIN/MAX TEMP. (°C)
BODY AND FLANGE	ASTM A105	-20°+120°
	ASTM A105N	-29°+120°
	ASTM A182 F316	-60°+230°
	ASTM A350 LF2	-40°+100°
STEM	ASTM A479 Tp316	-60°+230°
BALL	ASTM A182 F316	-60°+230°
STEM SEALS	PTFE	-196°+230°
	GRAPHITE	-
BALL SEATS	RPTFE	-196°+230°
	PEEK	-50°+250°
	NYLON	-40°+90°
	DEVLON	-40°+150°
	METAL-TO-METAL	-60°+230°
O-RING	NBR	-30°+100°
	FKM	-40°+200°
	EPDM	-50°+150°
	MVQ	-50°+150°
STUD/NUT	ASTM A193 B7/Gr. 2H	
	ASTM A193 B8/Gr. 8	
	ASTM A320 L7/Gr. 7	

PROVISIONS

API-6D ANSI B16.34 Specification for pipeline valves
 API 598 Valve inspection and test
 ANSI B.16.34 Steel valves Flanged and butt welding ends
 ANSI B16.5 Steel pipe flanges and flanged fittings
 ANSI B16.10 Face to face and end to end dimensions of ferrous valves
 ASTM American society for testing materials
 BS 6755 Testing of valves
 NACE MR-01-75 Sulfide stress cracking resistant metallic materials for oil field equipment
 UNI EN ISO 9001 quality system
 DIN/ISO 5211 for mounting

+ SBT300 2-WAY HIGH PRESSURE BALL VALVES

www.gemels.it

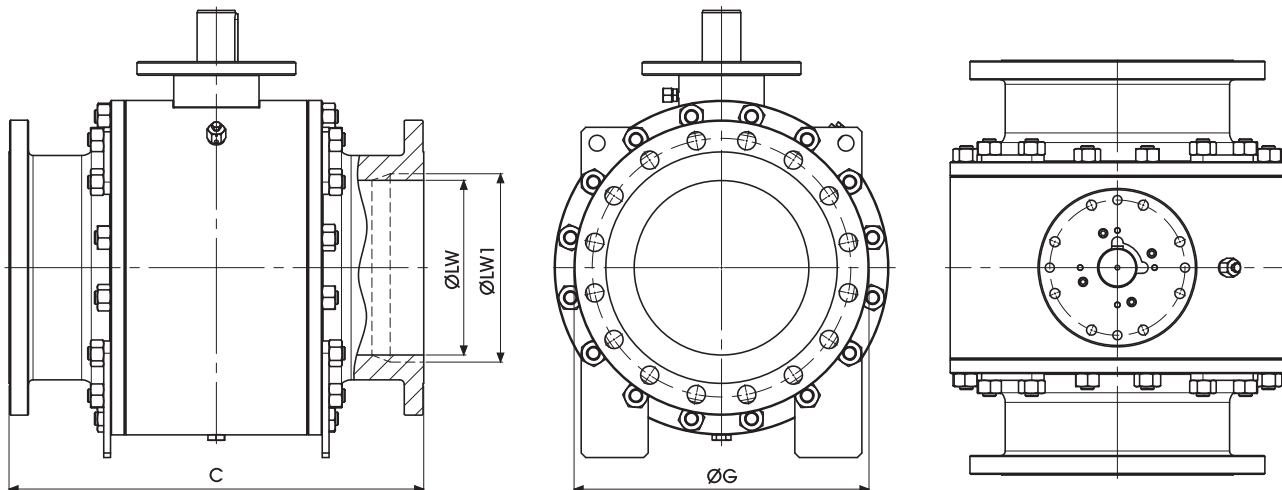

SBT 300 FB

Standard

TYPE	PN	INCH	LW	LW1	C RF	C RTJ	G
SBT A300	5 Mpa	6	150	-	403	419	317,5
SBT A300	5 Mpa	8	201	-	502	518	381
SBT A300	5 Mpa	10	252	-	568	584	444,5
SBT A300	5 Mpa	12	303	-	648	664	521
SBT A300	5 Mpa	14	334	-	762	778	584,5
SBT A300	5 Mpa	16	385	-	838	854	648
SBT A300	5 Mpa	18	436	-	914	930	711,5
SBT A300	5 Mpa	20	487	-	991	1010	775
SBT A300	5 Mpa	22	538	-	1092	1114	840*
SBT A300	5 Mpa	24	589	-	1143	1165	914,5

SBT 300 RB

Standard

TYPE	PN	INCH	LW	LW1	C RF	C RTJ	G
SBT A300	5 Mpa	8x6	150	201	502	518	381
SBT A300	5 Mpa	10x8	201	252	568	584	444,5
SBT A300	5 Mpa	12x8	201	303	648	664	521
SBT A300	5 Mpa	14x10	252	334	762	778	584,5
SBT A300	5 Mpa	16x12	303	385	838	854	648
SBT A300	5 Mpa	18x14	334	436	914	930	711,5
SBT A300	5 Mpa	20x16	385	487	991	1010	775
SBT A300	5 Mpa	24x20	487	589	1143	1165	914,5
SBT A300	5 Mpa	28x24	589	684	1346	1372	1035*
SBT A300	5 Mpa	30x24	589	735	1397	1422	1090*

* according to MSS SP44

SBT

+ SBT600 2-WAY HIGH PRESSURE BALL VALVES

Specialist in Ball Valves

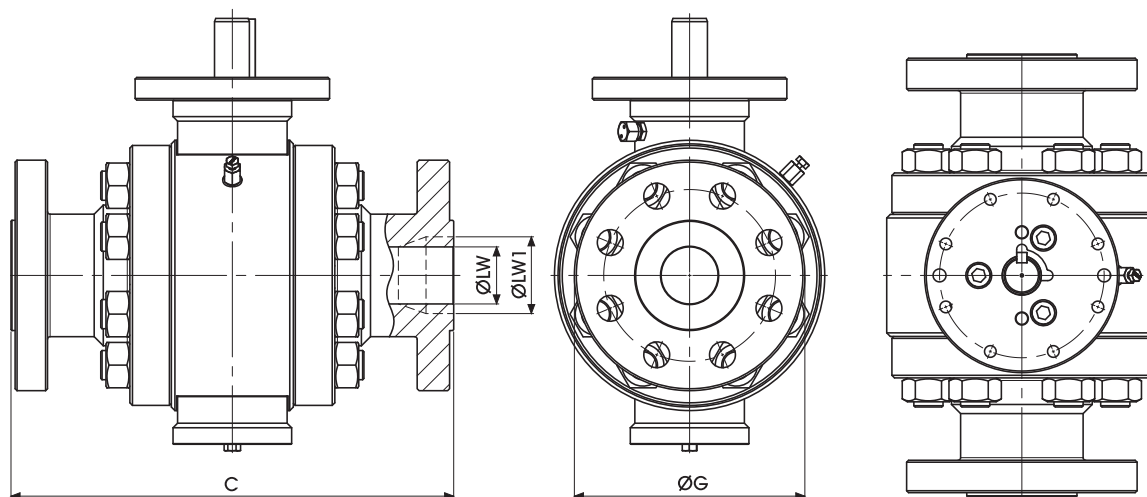

SBT 600 FB

Standard

TYPE	PN	INCH	LW	LW1	C RF	C RTJ	G
SBT A600	10 Mpa	2	49	-	292	295	165,5
SBT A600	10 Mpa	2 1/2	62	-	330	333	190,5
SBT A600	10 Mpa	3	74	-	356	359	210
SBT A600	10 Mpa	4	100	-	432	435	273,5

SBT 600 RB

Standard

TYPE	PN	INCH	LW	LW1	C RF	C RTJ	G
SBT A600	10 Mpa	2x1 1/2	38	49	292	295	165,5
SBT A600	10 Mpa	3x2 1/2	62	74	356	359	210
SBT A600	10 Mpa	3x2	49	100	432	435	273,5
SBT A600	10 Mpa	6x4	100	150	559	562	356

SPLIT BODY ANSI600 PN100 FULL AND REDUCED BORE

COMPONENTS	MATERIAL	MIN/MAX TEMP. (°C)
BODY AND FLANGE	ASTM A105	-20°+120°
	ASTM A105N	-29°+120°
	ASTM A182 F316	-60°+230°
	ASTM A350 LF2	-40°+100°
STEM	ASTM A479 Tp316	-60°+230°
BALL	ASTM A182 F316	-60°+230°
STEM SEALS	PTFE	-196°+230°
	GRAPHITE	-
BALL SEATS	RPTFE	-196°+230°
	PEEK	-50°+250°
	NYLON	-40°+90°
	DEVLON	-40°+150°
	METAL-TO-METAL	-60°+230°
O-RING	NBR	-30°+100°
	FKM	-40°+200°
	EPDM	-50°+150°
	MVQ	-50°+150°
STUD/NUT	ASTM A193 B7/Gr. 2H	
	ASTM A193 B8/Gr. 8	
	ASTM A320 L7/Gr. 7	

PROVISIONS

API-6D ANSI B16.34 Specification for pipeline valves
 API 598 Valve inspection and test
 ANSI B.16.34 Steel valves Flanged and butt welding ends
 ANSI B16.5 Steel pipe flanges and flanged fittings
 ANSI B16.10 Face to face and end to end dimensions of ferrous valves
 ASTM American society for testing materials
 BS 6755 Testing of valves
 NACE MR-01-75 Sulfide stress cracking resistant metallic materials for oil field equipment
 UNI EN ISO 9001 quality system
 DIN/ISO 5211 for mounting

+ SBT600 2-WAY HIGH PRESSURE BALL VALVES

www.gemels.it

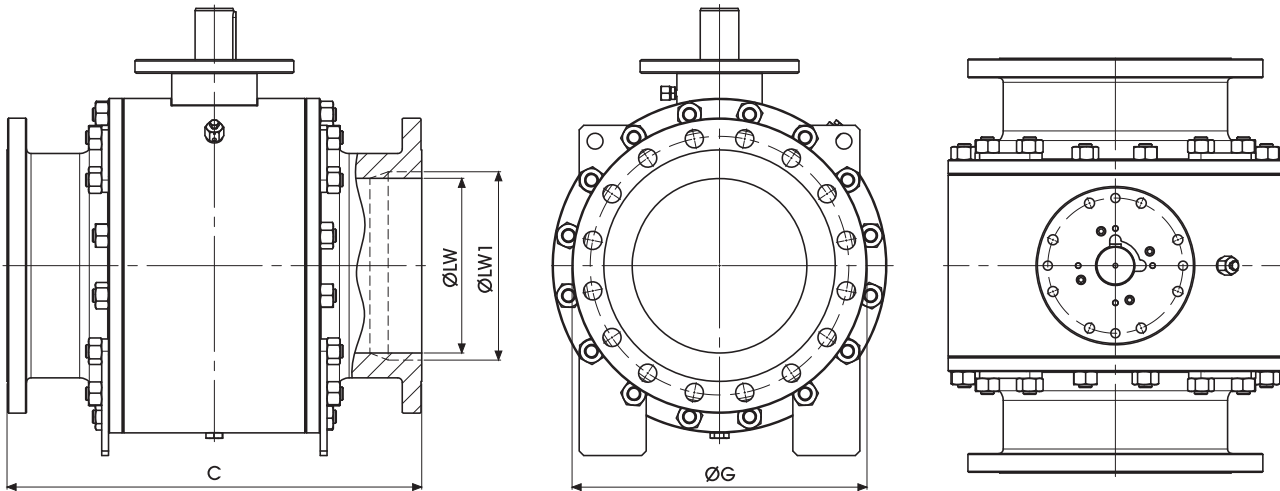

SBT 600 FB

Standard

TYPE	PN	INCH	LW	LW1	C RF	C RTJ	G
SBT A600	10 Mpa	6	150	-	559	562	356
SBT A600	10 Mpa	8	201	-	660	664	419,5
SBT A600	10 Mpa	10	252	-	787	791	508
SBT A600	10 Mpa	12	303	-	838	841	559
SBT A600	10 Mpa	14	334	-	889	892	603,5
SBT A600	10 Mpa	16	385	-	991	994	686
SBT A600	10 Mpa	18	436	-	1092	1095	743
SBT A600	10 Mpa	20	487	-	1194	1200	813
SBT A600	10 Mpa	22	538	-	1295	1305	870*
SBT A600	10 Mpa	24	589	-	1397	1407	940

SBT 600 RB

Standard

TYPE	PN	INCH	LW	LW1	C RF	C RTJ	G
SBT A600	10 Mpa	8x6	150	201	660	664	419,5
SBT A600	10 Mpa	10x8	201	252	787	791	508
SBT A600	10 Mpa	12x8	201	303	838	841	559
SBT A600	10 Mpa	14x10	252	334	889	892	603,5
SBT A600	10 Mpa	16x12	303	385	991	994	686
SBT A600	10 Mpa	18x14	334	436	1092	1095	743
SBT A600	10 Mpa	20x16	385	487	1194	1200	813
SBT A600	10 Mpa	24x20	487	589	1397	1407	940
SBT A600	10 Mpa	28x24	589	684	1549	1562	1075*
SBT A600	10 Mpa	30x24	589	735	1651	1664	1130*

* according to MSS SP44

SBT

+ SBT900 2-WAY HIGH PRESSURE BALL VALVES

Specialist in Ball Valves

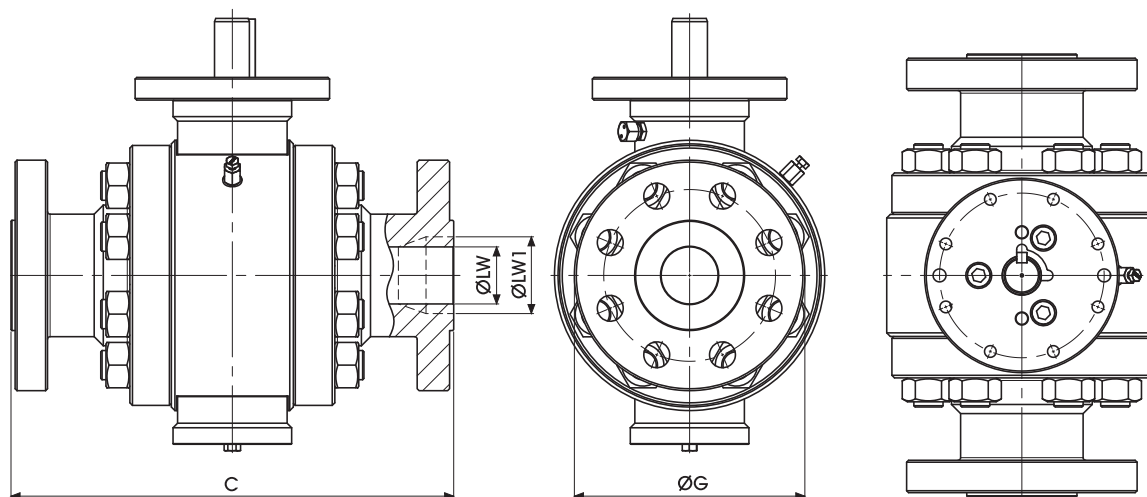

SBT 900 FB

Standard

TYPE	PN	INCH	LW	LW1	C RF	C RTJ	G
SBT A900	15 Mpa	2	49	-	368	371	216
SBT A900	15 Mpa	2 1/2	62	-	419	422	244,5
SBT A900	15 Mpa	3	74	-	381	384	241,5
SBT A900	15 Mpa	4	100	-	457	460	292,5

SBT 900 RB

Standard

TYPE	PN	INCH	LW	LW1	C RF	C RTJ	G
SBT A900	15 Mpa	2x1 1/2	38	49	368	371	216
SBT A900	15 Mpa	3x2 1/2	62	74	381	384	241,5
SBT A900	15 Mpa	3x2	49	100	457	460	292,5
SBT A900	15 Mpa	6x4	100	150	610	613	381

SPLIT BODY ANSI900 PN150 FULL AND REDUCED BORE

COMPONENTS	MATERIAL	MIN/MAX TEMP. (°C)
BODY AND FLANGE	ASTM A105	-20°+120°
	ASTM A105N	-29°+120°
	ASTM A182 F316	-60°+230°
	ASTM A350 LF2	-40°+100°
STEM	ASTM A479 Tp316	-60°+230°
BALL	ASTM A182 F316	-60°+230°
STEM SEALS	PTFE	-196°+230°
	GRAPHITE	-
BALL SEATS	RPTFE	-196°+230°
	PEEK	-50°+250°
	NYLON	-40°+90°
	DEVLON	-40°+150°
	METAL-TO-METAL	-60°+230°
O-RING	NBR	-30°+100°
	FKM	-40°+200°
	EPDM	-50°+150°
	MVQ	-50°+150°
STUD/NUT	ASTM A193 B7/Gr. 2H	
	ASTM A193 B8/Gr. 8	
	ASTM A320 L7/Gr. 7	

PROVISIONS

API-6D ANSI B16.34 Specification for pipeline valves
 API 598 Valve inspection and test
 ANSI B.16.34 Steel valves Flanged and butt welding ends
 ANSI B16.5 Steel pipe flanges and flanged fittings
 ANSI B16.10 Face to face and end to end dimensions of ferrous valves
 ASTM American society for testing materials
 BS 6755 Testing of valves
 NACE MR-01-75 Sulfide stress cracking resistant metallic materials for oil field equipment
 UNI EN ISO 9001 quality system
 DIN/ISO 5211 for mounting

+ SBT900 2-WAY HIGH PRESSURE BALL VALVES

www.gemels.it

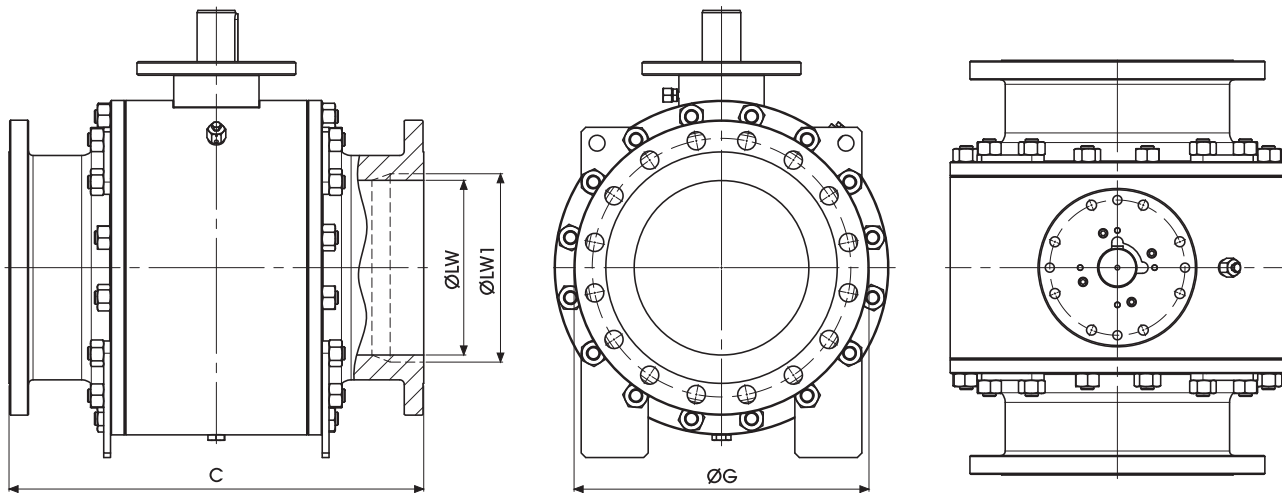

SBT 900 FB

Standard

TYPE	PN	INCH	LW	LW1	C RF	C RTJ	G
SBT A900	15 Mpa	6	150	-	610	613	381
SBT A900	15 Mpa	8	201	-	737	740	470
SBT A900	15 Mpa	10	252	-	838	841	546,5
SBT A900	15 Mpa	12	303	-	965	968	610
SBT A900	15 Mpa	14	322	-	1029	1038	641,5
SBT A900	15 Mpa	16	373	-	1130	1140	705
SBT A900	15 Mpa	18	423	-	1219	1232	787,5
SBT A900	15 Mpa	20	471	-	1321	1334	857,5
SBT A900	15 Mpa	22	522	-	-	-	-
SBT A900	15 Mpa	24	570	-	1549	1568	1041,5

SBT 900 RB

Standard

TYPE	PN	INCH	LW	LW1	C RF	C RTJ	G
SBT A900	15 Mpa	8x6	150	201	737	740	470
SBT A900	15 Mpa	10x8	201	252	838	841	546,5
SBT A900	15 Mpa	12x8	201	303	965	968	610
SBT A900	15 Mpa	14x10	252	322	1029	1038	641,5
SBT A900	15 Mpa	16x12	303	373	1130	1140	705
SBT A900	15 Mpa	18x14	322	423	1219	1232	787,5
SBT A900	15 Mpa	20x16	373	471	1321	1334	857,5
SBT A900	15 Mpa	24x20	471	570	1549	1568	1041,5
SBT A900	15 Mpa	28x24	570	665	-	-	-
SBT A900	15 Mpa	30x24	570	712	1880	1902	-

SBT

+ SBT1500

2-WAY HIGH PRESSURE BALL VALVES

Specialist in Ball Valves

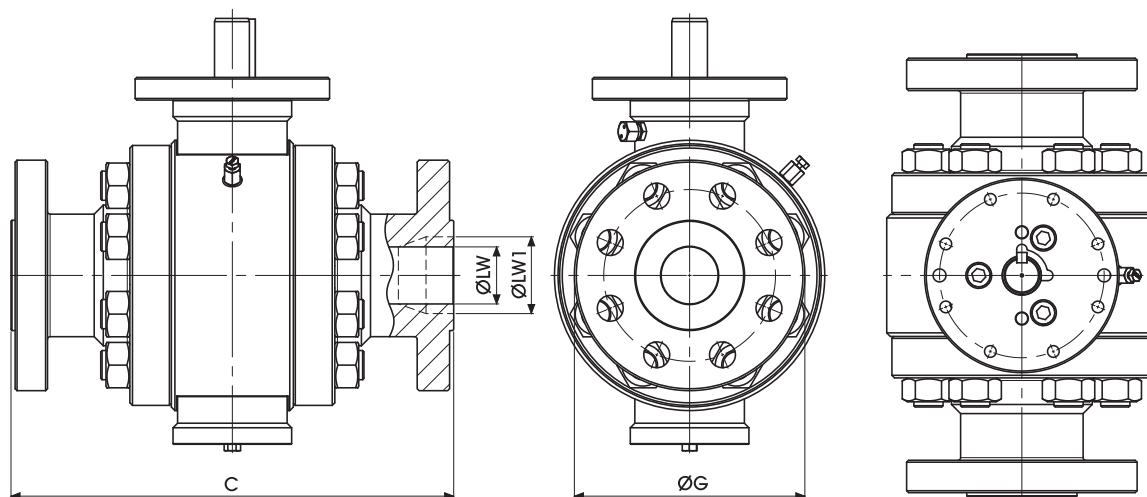

SBT 1500 FB

Standard

TYPE	PN	INCH	LW	LW1	C RF	C RTJ	G
SBT A1500	25 Mpa	2	49	-	368	371	216
SBT A1500	25 Mpa	2 1/2	62	-	419	422	244,5
SBT A1500	25 Mpa	3	74	-	470	473	267
SBT A1500	25 Mpa	4	100	-	546	549	311,5

SBT 1500 RB

Standard

TYPE	PN	INCH	LW	LW1	C RF	C RTJ	G
SBT A1500	25 Mpa	2x1 1/2	38	49	368	371	216
SBT A1500	25 Mpa	3x2 1/2	62	74	470	473	267
SBT A1500	25 Mpa	3x2	49	100	546	549	311,5
SBT A1500	25 Mpa	6x4	100	144	705	711	394

SPLIT BODY ANSI1500 PN250 FULL AND REDUCED BORE

COMPONENTS	MATERIAL	MIN/MAX TEMP. (°C)
BODY AND FLANGE	ASTM A105	-20°+120°
	ASTM A105N	-29°+120°
	ASTM A182 F316	-60°+230°
	ASTM A350 LF2	-40°+100°
STEM	ASTM A479 Tp316	-60°+230°
BALL	ASTM A182 F316	-60°+230°
STEM SEALS	PTFE	-196°+230°
	GRAPHITE	-
BALL SEATS	RPTFE	-196°+230°
	PEEK	-50°+250°
	NYLON	-40°+90°
	DEVLON	-40°+150°
	METAL-TO-METAL	-60°+230°
O-RING	NBR	-30°+100°
	FKM	-40°+200°
	EPDM	-50°+150°
	MVQ	-50°+150°
STUD/NUT	ASTM A193 B7/Gr. 2H	
	ASTM A193 B8/Gr. 8	
	ASTM A320 L7/Gr. 7	

PROVISIONS

API-6D ANSI B16.34 Specification for pipeline valves
 API 598 Valve inspection and test
 ANSI B.16.34 Steel valves Flanged and butt welding ends
 ANSI B16.5 Steel pipe flanges and flanged fittings
 ANSI B16.10 Face to face and end to end dimensions of ferrous valves
 ASTM American society for testing materials
 BS 6755 Testing of valves
 NACE MR-01-75 Sulfide stress cracking resistant metallic materials for oil field equipment
 UNI EN ISO 9001 quality system
 DIN/ISO 5211 for mounting

+ SBT1500

2-WAY HIGH PRESSURE BALL VALVES

www.gemels.it

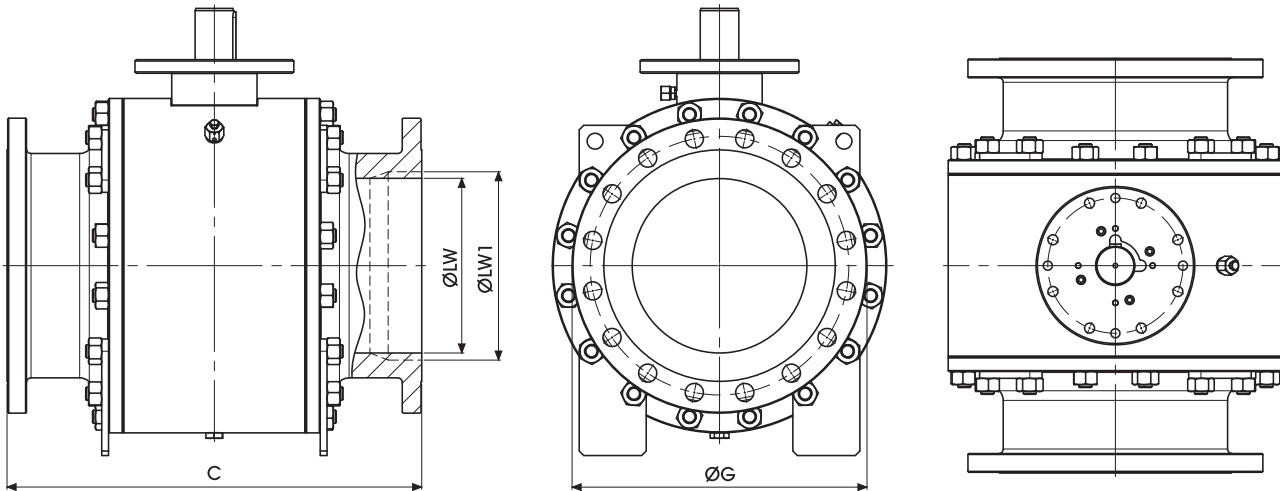

SBT 1500 FB

Standard

TYPE	PN	INCH	LW	LW1	C RF	C RTJ	G
SBT A1500	25 Mpa	6	144	-	705	711	394
SBT A1500	25 Mpa	8	192	-	832	841	483
SBT A1500	25 Mpa	10	239	-	991	1000	584,5
SBT A1500	25 Mpa	12	287	-	1130	1146	673,5
SBT A1500	25 Mpa	14	315	-	1257	1276	749,5
SBT A1500	25 Mpa	16	360	-	1384	1407	825,5
SBT A1500	25 Mpa	18	406	-	1537	1559	914,5
SBT A1500	25 Mpa	20	454	-	1664	1686	984,5
SBT A1500	25 Mpa	22	500	-	-	-	-
SBT A1500	25 Mpa	24	546	-	-	1972	1168,5

SBT 1500 RB

Standard

TYPE	PN	INCH	LW	LW1	C RF	C RTJ	G
SBT A1500	25 Mpa	8x6	144	192	832	841	483
SBT A1500	25 Mpa	10x8	192	239	991	1000	584,5
SBT A1500	25 Mpa	12x8	192	287	1130	1146	673,5
SBT A1500	25 Mpa	14x10	239	315	1257	1276	749,5
SBT A1500	25 Mpa	16x12	287	360	1384	1407	825,5
SBT A1500	25 Mpa	18x14	315	406	1537	1559	914,5
SBT A1500	25 Mpa	20x16	360	454	1664	1686	984,5
SBT A1500	25 Mpa	24x20	454	546	-	1972	1168,5
SBT A1500	25 Mpa	28x24	546	641	-	-	-
SBT A1500	25 Mpa	30x24	546	686	-	-	-

SBT

+ SBT2500

2-WAY HIGH PRESSURE BALL VALVES

Specialist in Ball Valves

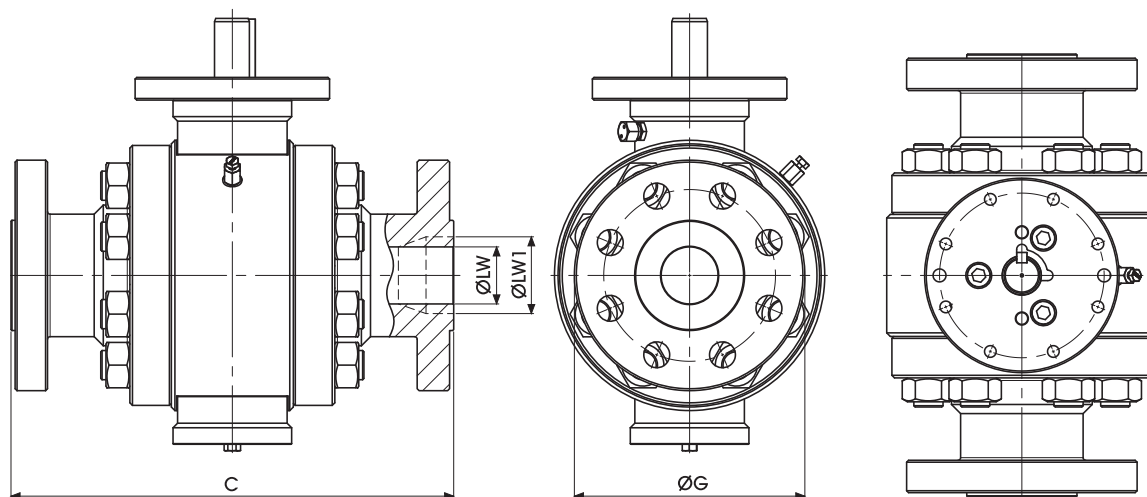

SBT 2500 FB

Standard

TYPE	PN	INCH	LW	LW1	C RF	C RTJ	G
SBT A2500	42 Mpa	2	42	-	451	454	235
SBT A2500	42 Mpa	2 1/2	52	-	508	540	267
SBT A2500	42 Mpa	3	62	-	578	584	305
SBT A2500	42 Mpa	4	87	-	673	683	356

SBT 2500 RB

Standard

TYPE	PN	INCH	LW	LW1	C RF	C RTJ	G
SBT A2500	42 Mpa	2x1 1/2	38	42	451	454	235
SBT A2500	42 Mpa	3x2 1/2	52	62	578	584	305
SBT A2500	42 Mpa	3x2	42	87	673	683	356
SBT A2500	42 Mpa	6x4	87	131	914	927	483

SPLIT BODY ANSI2500 PN420 FULL AND REDUCED BORE

COMPONENTS	MATERIAL	MIN/MAX TEMP. (°C)
BODY AND FLANGE	ASTM A105	-20°+120°
	ASTM A105N	-29°+120°
	ASTM A182 F316	-60°+230°
	ASTM A350 LF2	-40°+100°
STEM	ASTM A479 Tp316	-60°+230°
BALL	ASTM A182 F316	-60°+230°
STEM SEALS	PTFE	-196°+230°
	GRAPHITE	-
BALL SEATS	RPTFE	-196°+230°
	PEEK	-50°+250°
	NYLON	-40°+90°
	DEVLON	-40°+150°
	METAL-TO-METAL	-60°+230°
O-RING	NBR	-30°+100°
	FKM	-40°+200°
	EPDM	-50°+150°
	MVQ	-50°+150°
STUD/NUT	ASTM A193 B7/Gr. 2H	
	ASTM A193 B8/Gr. 8	
	ASTM A320 L7/Gr. 7	

PROVISIONS

API-6D ANSI B16.34 Specification for pipeline valves
 API 598 Valve inspection and test
 ANSI B.16.34 Steel valves Flanged and butt welding ends
 ANSI B16.5 Steel pipe flanges and flanged fittings
 ANSI B16.10 Face to face and end to end dimensions of ferrous valves
 ASTM American society for testing materials
 BS 6755 Testing of valves
 NACE MR-01-75 Sulfide stress cracking resistant metallic materials for oil field equipment
 UNI EN ISO 9001 quality system
 DIN/ISO 5211 for mounting

+ SBT2500

2-WAY HIGH PRESSURE BALL VALVES

www.gemels.it

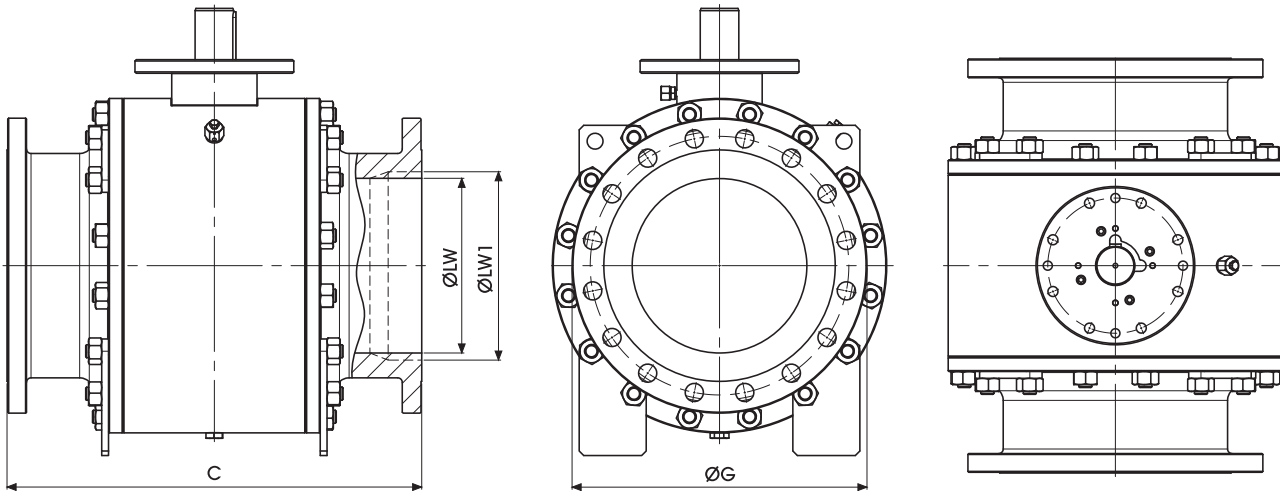

SBT 2500 FB

Standard

TYPE	PN	INCH	LW	LW1	C RF	C RTJ	G
SBT A2500	42 Mpa	6	131	-	914	927	483
SBT A2500	42 Mpa	8	179	-	1022	1038	552,5
SBT A2500	42 Mpa	10	223	-	1270	1294	673,5
SBT A2500	42 Mpa	12	265	-	1422	1445	762
SBT A2500	42 Mpa	14	292	-	-	-	-
SBT A2500	42 Mpa	16	333	-	-	-	-
SBT A2500	42 Mpa	18	374	-	-	-	-
SBT A2500	42 Mpa	20	419	-	-	-	-

SBT 2500 FB

Standard

TYPE	PN	INCH	LW	LW1	C RF	C RTJ	G
SBT A2500	42 Mpa	8x6	131	179	1022	1038	552,5
SBT A2500	42 Mpa	10x8	179	223	1270	1294	673,5
SBT A2500	42 Mpa	12x8	179	265	1422	1445	762
SBT A2500	42 Mpa	14x10	223	292	-	-	-
SBT A2500	42 Mpa	16x12	265	333	-	-	-
SBT A2500	42 Mpa	18x14	292	374	-	-	-
SBT A2500	42 Mpa	20x16	333	419	-	-	-
SBT A150	42 Mpa	18x14	334	436	864	876	635
SBT A150	42 Mpa	20x16	385	487	914	927	698,5
SBT A150	42 Mpa	24x20	487	589	1067	1080	813
SBT A150	42 Mpa	28x24	589	684	1245	-	925*
SBT A150	42 Mpa	30x24	589	735	1295	-	985*

* according to MSS SP44

SBT

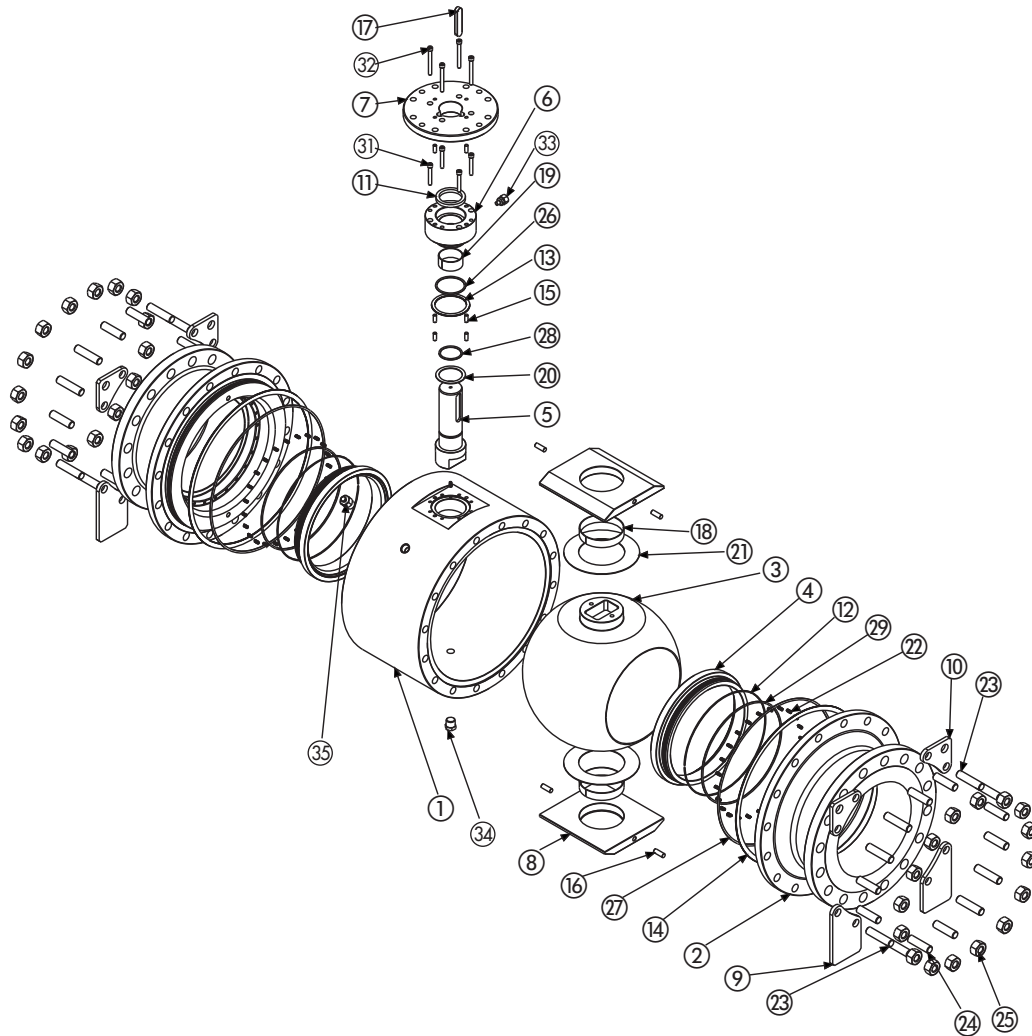

Carbon steel

Pos	Description	Material	Pos	Description	Material
1	Body	ASTM A105N	19	Stem Bushing	AISI 316 + N.F.C.
2	Clousure	ASTM A105N	20	Stem Thrust Washer	AISI 316 + N.F.C.
3	Ball	ASTM A182 F316	21	Ball Thrust Washer	AISI 316 + N.F.C.
4	Seat	ASTM A479 Tp.316/RPTFE	22	Spring Inconel	X750
5	Stem	ASTM A479 Tp.316	23	Stud ASTM	A193 B7
6	Bonnet	ASTM A105N	24	Support/Lifting Lug Stud	ASTM A193 B7
7	Cover Plate	ASTM A105N	25	Nut	ASTM A194 2H
8	Spacer	ASTM A516 Gr.60	26	Body/Bonnet o-ring	NBR
9	Valve Support	Fe 360	27	Body/Flange o-ring	NBR
10	Lifting Lug	Fe 360	28	Stem o-ring	NBR
11	Stem Gasket	GRAPHITE	29	Seat o-ring	NBR
12	Seat Gasket	GRAPHITE	30	Antistatic Device	ASTM A479 Tp.316
13	Body/Bonnet Gasket S.W.T.	GRAPHITE+316L	31	Bonnet T.C.E.I.	ASTM A193 B7
14	Body/Flange Gasket S.W.T.	GRAPHITE+316L	32	Cover Plate T.C.E.I.	ASTM A193 B7
15	Body/Bonnet/Cover Pin	100Cr6	33	Stem Injector	ASTM A479 Tp.316
16	Spacer Pin	100Cr6	34	Drain Plug	ASTM A479 Tp.316
17	Stem Key	C45	35	Vent Bleeder	ASTM A479 Tp.316
18	Ball Bushing	AISI 316 + N.F.C.			

On request

- Reduced bore
- O-Ring in FKM, EPDM, HNBR, KALREZ
- Seals in PTFE, PEEK, PA612, GEMPTFE, METAL TO METAL
- Pressure class ANSI 150-300-600 900-1500-2500
- Lever
- Gear
- Pneumatic and electrical actuator
- Locking device

For further special requests please consult our technical/commercial service

+ SBT 2-WAY HIGH PRESSURE BALL VALVES

www.gemels.it

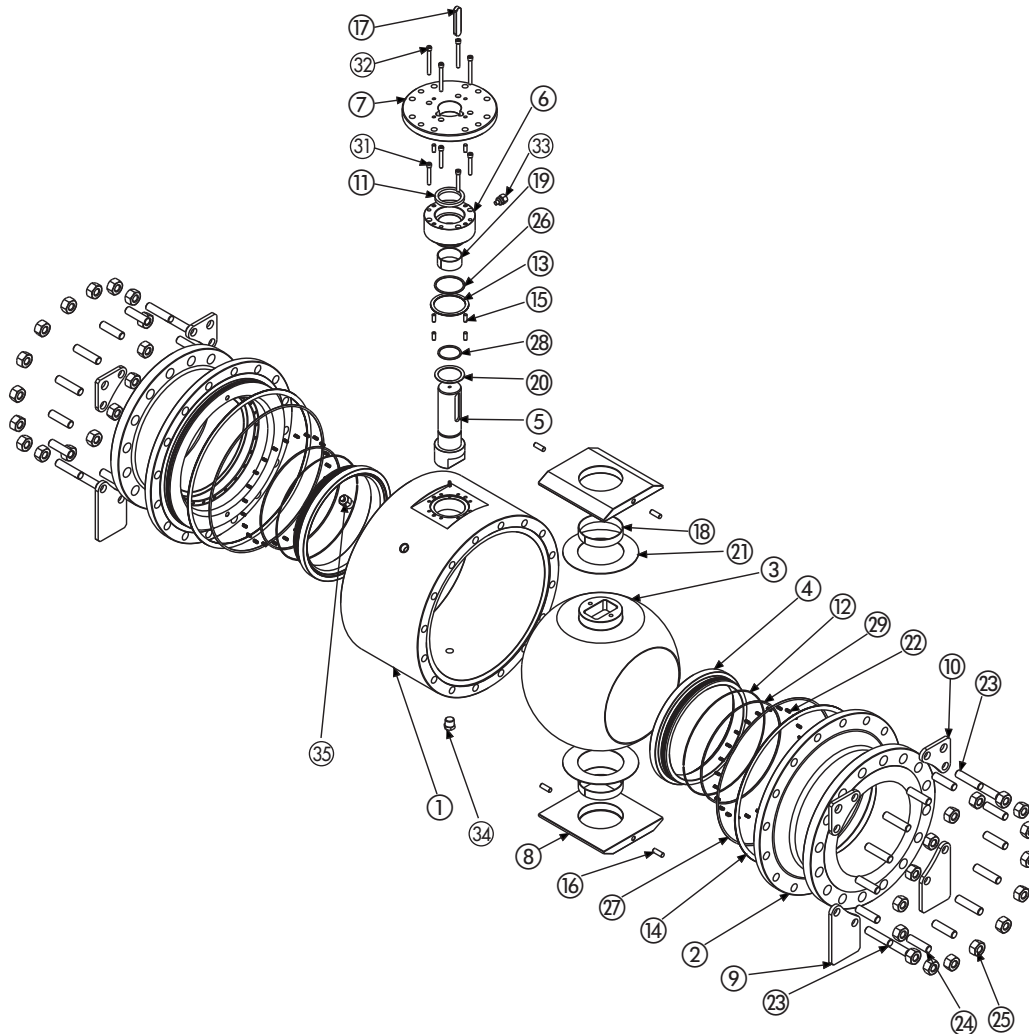

Stainless steel

Pos	Description	Material	Pos	Description	Material
1	Body	ASTM A182 F316	19	Stem Bushing	AISI 316 + N.F.C.
2	Closure	ASTM A182 F316	20	Stem Thrust Washer	AISI 316 + N.F.C.
3	Ball	ASTM A182 F316	21	Ball Thrust Washer	AISI 316 + N.F.C.
4	Seat	ASTM A182 F316 /RPTFE	22	Spring Inconel	X750
5	Stem	ASTM A479 Tp.316	23	Stud	ASTM A193 B8 Cl.8
6	Bonnet	ASTM A479 Tp.316	24	Support/Lifting Lug Stud	ASTM A193 B8 Cl.8
7	Cover Plate	ASTM A479 Tp.316	25	Nut	ASTM A194 Gr.8
8	Spacer	ASTM A240 Tp.316	26	Body/Bonnet o-ring	NBR
9	Valve Support	Fe 360	27	Body/Flange o-ring	NBR
10	Lifting Lug	Fe 360	28	Stem o-ring	NBR
11	Stem Gasket	GRAPHITE	29	Seat o-ring	NBR
12	Seat Gasket	GRAPHITE	30	Antistatic Device	ASTM A479 Tp.316
13	Body/Bonnet Gasket S.W.T.	GRAPHITE+316L	31	Bonnet T.C.E.I.	ASTM A193 B8 Cl.8
14	Body/Flange Gasket S.W.T.	GRAPHITE+316L	32	Cover Plate T.C.E.I.	ASTM A193 B8 Cl.8
15	Body/Bonnet/Cover Pin	100Cr6	33	Stem Injector	ASTM A479 Tp.316
16	Spacer Pin	100Cr6	34	Drain Plug	ASTM A479 Tp.316
17	Stem Key	C70	35	Vent Bleeder	ASTM A479 Tp.316
18	Ball Bushing	AISI 316 + N.F.C.			

On request

- Reduced bore
- O-Ring in FKM, EPDM, HNBR, KALREZ
- Seals in PTFE, PEEK, PA612, GEMPTFE, METAL TO METAL
- Pressure class ANSI 150-300-600 900-1500-2500
- Lever
- Gear
- Pneumatic and electrical actuator
- Locking device

For further special requests please consult our technical/commercial service

SBT

KITS

LOCKING - HANDLES - FLANGE LIMIT SWITCH - ACTUATOR - SEALS KIT



KITS

LOCKING - HANDLES
FLANGE - LIMIT SWITCHES
ACTUATORS - SEALS KITS

TECH

MATERIAL

OIL&GAS

GM1-GM - GN
SBF - SBT

OTHER

GHP - GPS - RF
BD - VU - VUJBA

GR

GRC - GRS

GPK

GPK2 - GPK3

G3K-4K

G3K - G4K

GV

GV2 - GV3

GB

GB2 - GB3 - GBF
GBS - GBC

GE

GEM - GE1 - GE2 - GE3
GE5 - GE3K - GEF
GES - GEC - GEV

+ Locking device

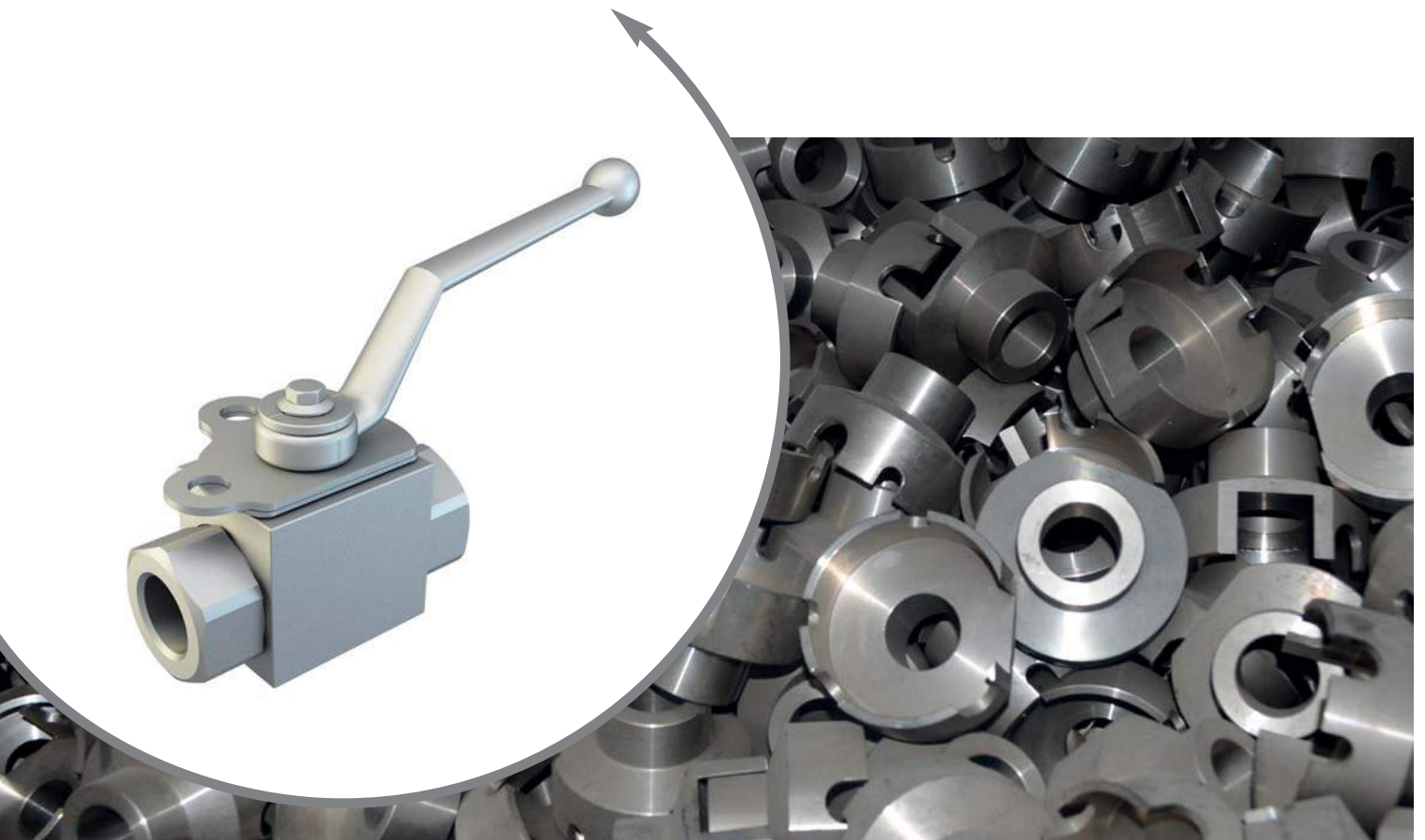

LKB FOR GM - GN

LKF FOR GE - GB - GHP - GPK

LKR FOR GR

SECURITY BLOCK FOR GE - GB - GHP - GPK - G3/4K

Locking

+ Locking device

Specialist in Ball Valves

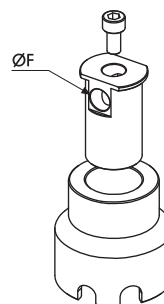

Padlock not included

LKB FOR GM - GN

TYPE	DN	SW	ØF	MATERIAL	TREATMENT	WEIGHT Kg	KIT CODE
LK6-B	6-10-13	9	9,5	CARBON STEEL	GALVANIZED	0,178	KMK00LK6B2Z
LK6-B	6-10-13	9	9,5	STAINLES STEEL	-	0,178	KMK00LK6B6H
LK20-B	20-25	14	10,5	CARBON STEEL	GALVANIZED	0,413	KMK00LK20B2Z
LK20-B	20-25	14	10,5	STAINLES STEEL	-	0,413	KMK00LK20B6H
LK32-B	32-40-50	17	10,5	CARBON STEEL	GALVANIZED	0,53	KMK00LK32B2Z
LK32-B	32-40-50	17	10,5	STAINLES STEEL	-	0,53	KMK00LK32B6H

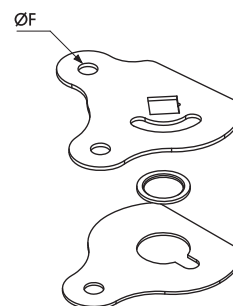
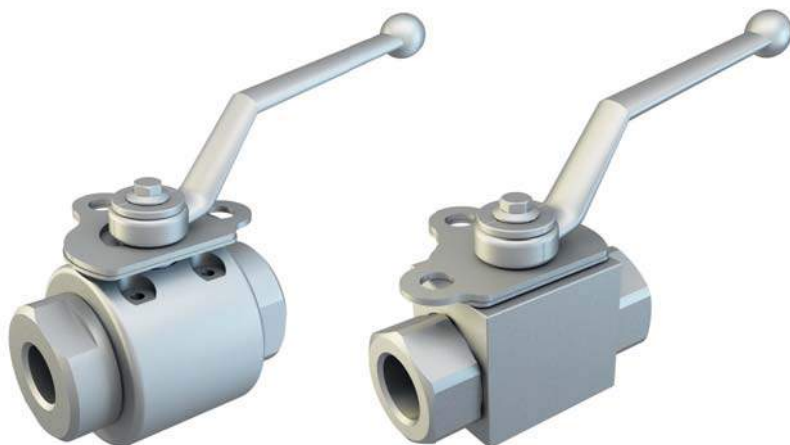

Padlock not included

LKF FOR GE - GB - GHP - GPK

TYPE	DN	SW	ØF	MATERIAL	TREATMENT	WEIGHT Kg	KIT CODE
LK6-F	6-10-13	9	9,5	CARBON STEEL	GALVANIZED	0,043	KOK00LK6F2Z
LK6-F	6-10-13	9	9,5	STAINLES STEEL	-	0,043	KOK00LK6F6H
LK20-F	20-25	14	9,5	CARBON STEEL	GALVANIZED	0,121	KOK00LK20F2Z
LK20-F	20-25	14	9,5	STAINLES STEEL	-	0,121	KOK00LK20F6H
LK32-F	32-40-50	17	9,5	CARBON STEEL	GALVANIZED	0,187	KOK00LK32F2Z
LK32-F	32-40-50	17	9,5	STAINLES STEEL	-	0,187	KOK00LK32F6H

"The company reserves the right to operate dimensional changes without prior notice".

+ Locking device

www.gemels.it

2016 - Edition 1

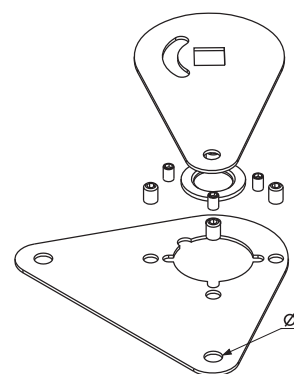
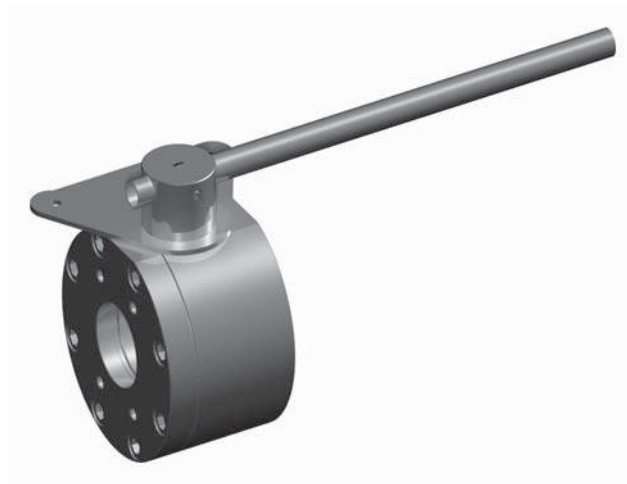

LKR FOR GR

TYPE	DN	SW	ØF	MATERIAL	TREATMENT	WEIGHT Kg	KIT CODE
LKR13	13	9	9,5	CARBON STEEL	GALVANIZED	0,1	KOK00LKR132Z
LKR13	13	9	9,5	STAINLESS STEEL	-	0,1	KOK00LKR136H
LKR20	20-25	14	9,5	CARBON STEEL	GALVANIZED	0,18	KOK00LKR202Z
LKR20	20-25	14	9,5	STAINLESS STEEL	-	0,18	KOK00LKR206H
LKR32	32-40-50	17	9,5	CARBON STEEL	GALVANIZED	0,34	KOK00LKR322Z
LKR32	32-40-50	17	9,5	STAINLESS STEEL	-	0,34	KOK00LKR326H
LKR65	65-80	19	9,5	CARBON STEEL	GALVANIZED	0,55	KOK00LKR652Z
LKR65	65-80	19	9,5	STAINLESS STEEL	-	0,55	KOK00LKR656H
LKR100	100	24	9,5	CARBON STEEL	GALVANIZED	1,08	KOK00LKR1002Z
LKR100	100	24	9,5	STAINLESS STEEL	-	1,08	KOK00LKR1006H

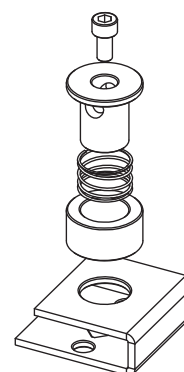

SECURITY BLOCK FOR GE - GB - GHP - GPK - G3/4K

TYPE	DN	SW	ØF	MATERIAL	TREATMENT	WEIGHT Kg	KIT CODE
SB6	6-10-13	9	6,25	CARBON STEEL	GALVANIZED	0,066	KOB00SB61Z
SB20	20-25	14	8,1	CARBON STEEL	GALVANIZED	0,221	KOB00SB201Z
SB32	32-40-50	17	8,1	CARBON STEEL	GALVANIZED	0,24	KOB00SB321Z



+ Handles

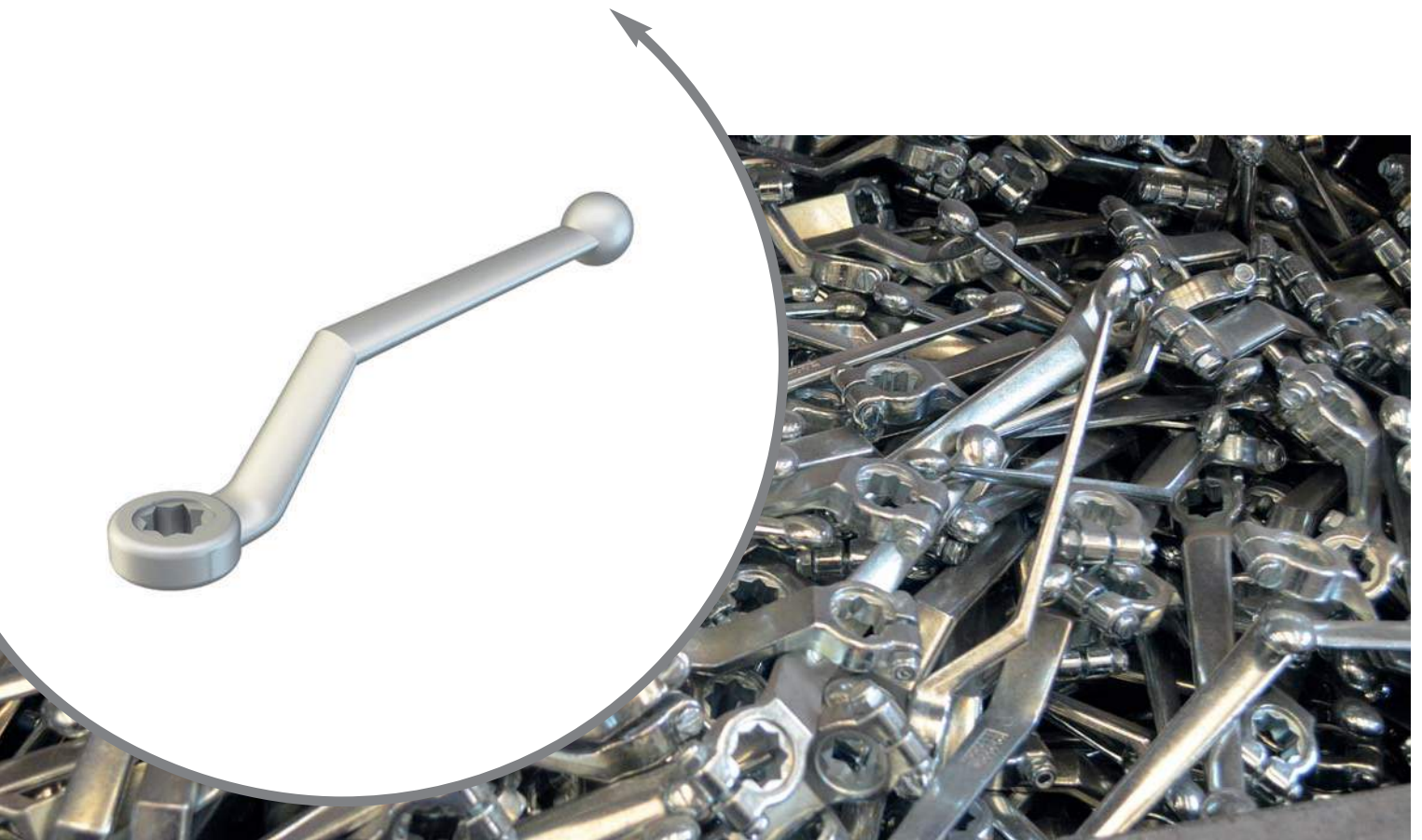

- BENT HANDLES**
- BUTTERFLY HANDLES**
- CUT BENT HANDLES**
- CUT STRAIGHT HANDLES**
- PIPE HANDLES**
- SHORT HANDLES**
- STRAIGHT HANDLES**

Handles

+ Handles

Specialist in Ball Valves

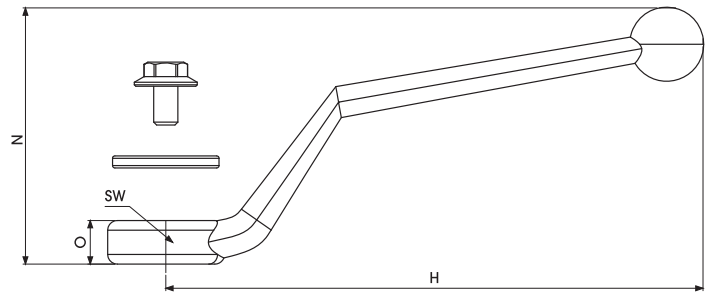

BENT HANDLES

SW	H	N	O	MATERIAL	TREATMENT	WEIGHT Kg	HANDLE CODE	KIT CODE
9	104,5	40,34	9	ZINC	GALVANIZED	0,054	C021330ZC	K06A0018859000C (only GE1 and GE5)
9	110	53	9	ZINC	GALVANIZED	0,082	C001010ZC	KOL0011ZZ
9	110	53	9	CARBON STEEL	GALVANIZED	0,097	C0010102Z	KOL0011ZZ
9	110	53	9	STAINLES STEEL	-	0,098	C0010106H	KOL00116H
14	180	48	13	ZINC	GALVANIZED	0,18	C008550ZC	KOL0016ZZ
14	180	48	14	CARBON STEEL	GALVANIZED	0,248	C0069202Z	KOL00152Z
14	180	48	14	STAINLES STEEL	-	0,257	C0069206H	KOL00156H
17	300	71	14	CARBON STEEL	GALVANIZED	0,662	C0092502Z	KBL00132Z
17	300	71	14	STAINLES STEEL	-	0,675	C0092506H	KBL00136H

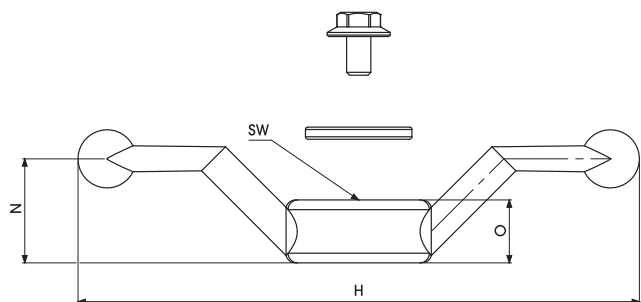

BUTTERFLY HANDLES

SW	H	N	O	MATERIAL	TREATMENT	WEIGHT Kg	HANDLE CODE	KIT CODE
9	116	27,5	13	ZINC	GALVANIZED	0,107	C010740ZZ	KOL0018ZZ
14	116	27,5	13	ZINC	GALVANIZED	0,097	C010750ZZ	KOL0019ZZ

+ Handles

www.gemels.it

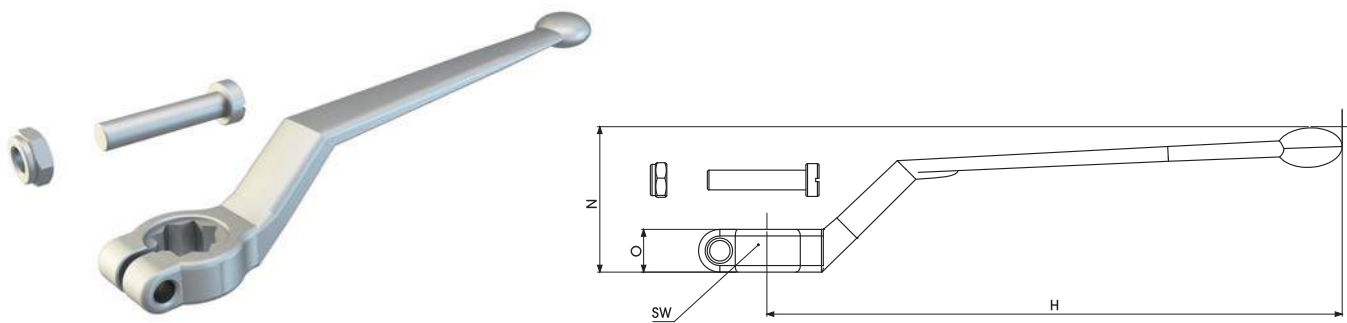

CUT BENT HANDLES

SW	H	N	O	MATERIAL	TREATMENT	WEIGHT Kg	HANDLE CODE	KIT CODE
14	180	53	13	ZINC	GALVANIZED	0,195	C001200ZC	KEL007ZZ
14	330	71	14	ALLUMINIUM	RED PAINTED	0,222	C000360AV	KBL0010HV

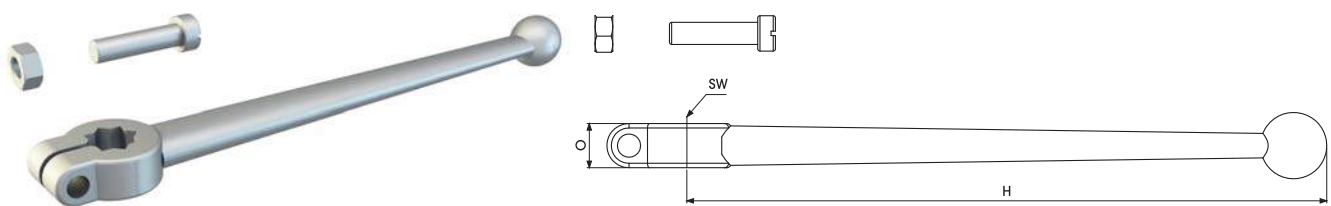

CUT STRAIGHT HANDLES

SW	H	N	O	MATERIAL	TREATMENT	WEIGHT Kg	HANDLE CODE	KIT CODE
9	145	10	-	ZINC	GALVANIZED	0,042	C000020ZZ	KEL006ZZ
14	300	14	-	ALLUMINIUM	RED PAINTED	0,208	C002890AV	KBL009HV



PIPE HANDLES

SW	H	N	O	MATERIAL	TREATMENT	WEIGHT Kg	HANDLE CODE	KIT CODE
19	650	73,5	-	CARBON STEEL	GALVANIZED	2,112	C0012502Z	KOL00202Z
19	650	73,5	-	STAINLES STEEL	-	2,312	C0012506H	KOL00206H
24	650	78	-	CARBON STEEL	GALVANIZED	3,912	C0012502Z	KOL00212Z
24	650	78	-	STAINLES STEEL	-	4	C0012506H	KOL00216H

Handles

+ Handles

Specialist in Ball Valves

2016 - Edition 1

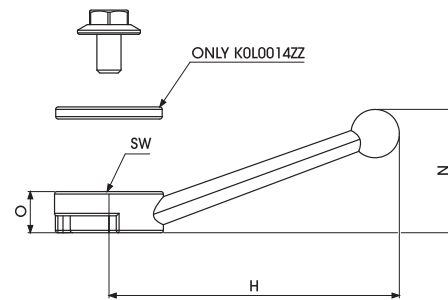
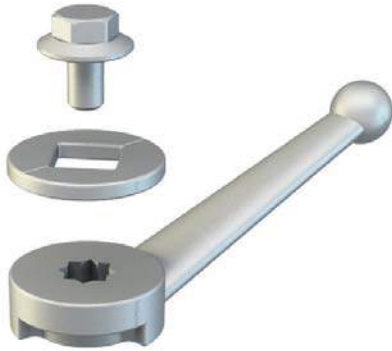

SHORT HANDLES

SW	H	N	O	MATERIAL	TREATMENT	WEIGHT Kg	HANDLE CODE	KIT CODE
6	60	25,50	8,5	ZINC	RED PAINTED	0,024	C001490ZV	K1LT117ZV
9	60	25,50	8,5	ZINC	GALVANIZED	0,022	C009490ZZ	K0L0014ZZ



STRAIGHT HANDLES

SW	H	N	O	MATERIAL	TREATMENT	WEIGHT Kg	HANDLE CODE	KIT CODE
14	200	-	14	ALLUMINIUM	RED PAINTED	0,109	C002950AV	KEL008HV
17	300	-	13	CARBON STEEL	GALVANIZED	0,457	C0081302Z	K0L00122Z
17	300	-	13	STAINLES STEEL	-	0,467	C0081306H	K0L00126H

+ Flange

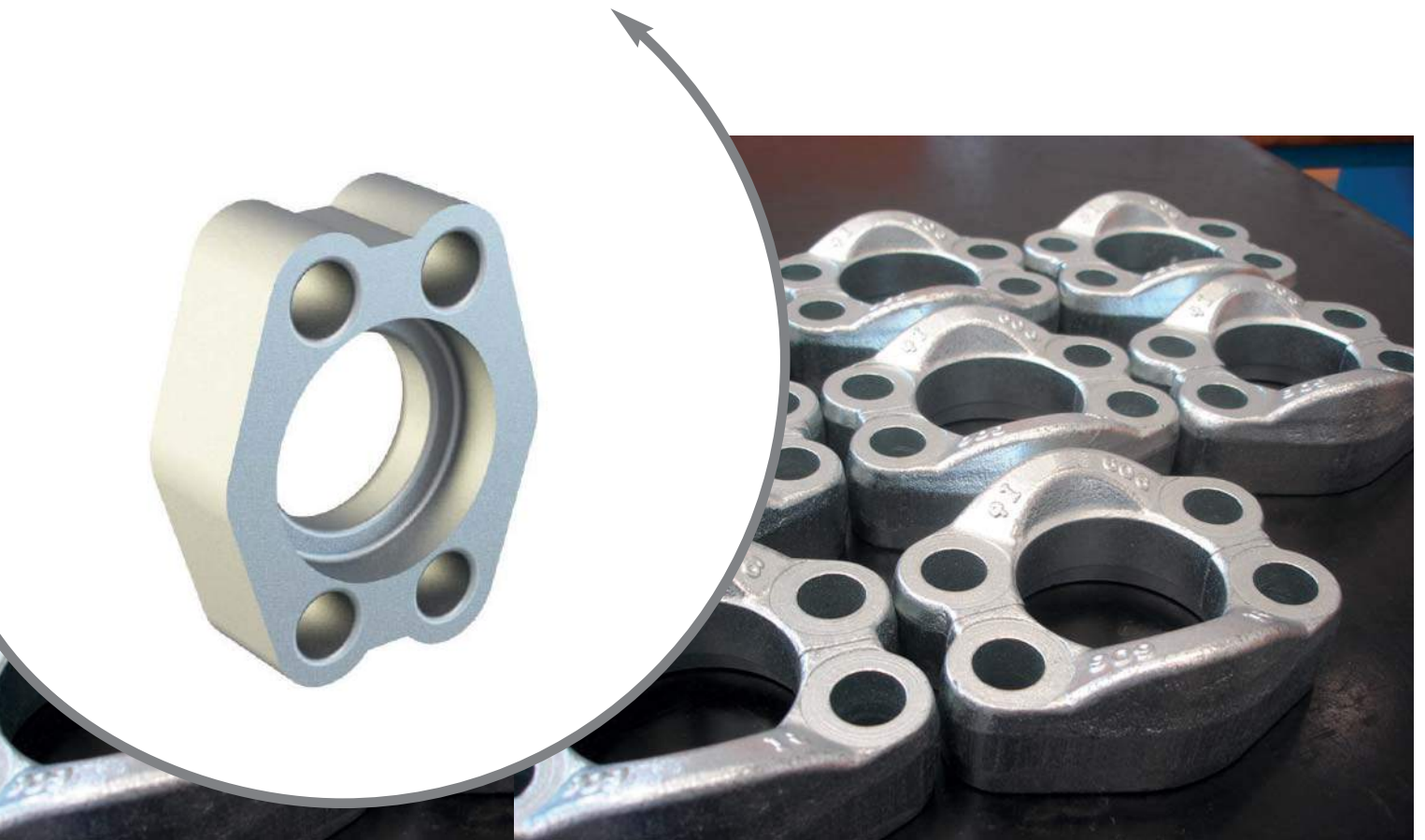

COUPLE SPLIT FLANGE
UN CUT SPLIT FLANGE

Flange

+ Flange

Specialist in Ball Valves

Carbon Steel

COUPLE SPLIT FLANGE

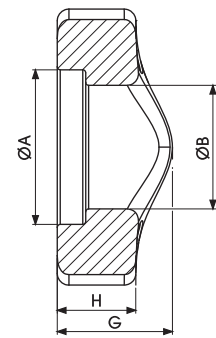
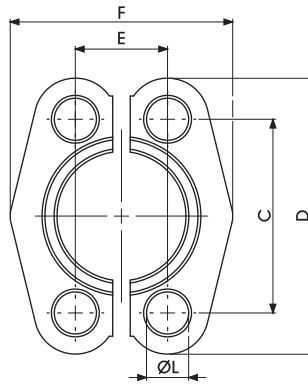

COUPLE SPLIT FLANGE S3000/CODE 61 WITHOUT SCREW

TYPE	MAX PRESSURE	A	B	C	D	E	F	G	H	I	L	METRIC	UNC	WEIGHT Kg	ITEM CODE
1/2"	21 MPa	30,96	24,26	38,10	54	17,48	45,6	19	13	6,22	8,5	M8 x 25	5/16 x 1 1/4	0,135	C0071802Z
3/4"	21 MPa	38,89	32,13	47,63	65	22,23	51,8	22	14	6,22	10,5	M10 x 30	3/8 x 1 1/4	0,175	C0071902Z
1"	21 MPa	45,24	38,48	52,37	70	26,19	58,4	24	16	7,49	10,5	M10 x 35	3/8 x 1 1/4	0,23	C0072002Z
1 1/4"	21 MPa	51,59	43,69	58,72	79	30,18	72,6	22	16	7,49	12	M10 x 35	7/16 x 1 1/2	0,30	C0072102Z
1 1/2"	21 MPa	61,09	50,80	69,85	94	35,71	82,2	25	16	7,49	13,5	M12 x 35	1/2 x 1 1/2	0,475	C0072202Z
2"	21 MPa	72,24	64,74	77,77	102	42,88	96,4	26	16	9,02	13,5	M12 x 35	1/2 x 1 1/2	0,535	C0076002Z
2 1/2"	17.5 MPa	84,94	74,93	88,90	114	50,80	108,2	38	19	9,02	13,5	M12 x 40	1/2 x 1 1/2	0,78	C0076302Z
3"	13.8 MPa	102,39	90,93	106,38	135	61,93	130,6	41	22	9,02	16,75	M16 x 50	5/8 x 2	1,27	C0076402Z

COUPLE SPLIT FLANGE S6000/CODE 62 WITHOUT SCREW

TYPE	MAX PRESSURE	A	B	C	D	E	F	G	H	I	L	METRIC	UNC	WEIGHT Kg	ITEM CODE
1/2"	42 MPa	32,54	24,64	40,49	56	18,24	47,2	22	16	7,24	8,5	M8 X 30	5/16 x 1 1/4	0,165	C0076502Z
3/4"	42 MPa	42,06	32,51	50,80	71	23,80	60	28	19	8,26	10,5	M10 X 35	3/8 x 1 1/2	0,325	C0076602Z
1"	42 MPa	48,41	38,86	57,15	81	27,76	69,9	33	24	9,02	13,5	M12 X 45	-	0,48	C0076702Z
1 1/4"	42 MPa	54,76	44,45	66,68	95	31,75	77,2	38	27	9,78	14,5	M12 X 50	1/2 x 1 3/4	0,73	C0076802Z
1 1/2"	42 MPa	64,29	51,56	79,38	113	36,50	95	43	30	12,07	16,75	M16 X 55	5/8 x 2	1,30	C0076902Z
2"	42 MPa	80,16	67,56	96,82	133	44,45	113,8	52	37	12,07	21	M20 X 65	3/4 x 2 1/2	1,95	C0077002Z
2 1/2"	42 MPa	108,90	90	123,80	180	58,80	150,2	45	45	20,50	26	M24 X 75	-	4,55	C0077102Z
3"	42 MPa	132,50	115	152,40	215	71,60	198,16	55	55	25,50	31	M30 X 90	-	8,25	C0077202Z

+ Flange

www.gemels.it

2016 - Edition 1

Carbon Steel

UN CUT SPLIT FLANGE

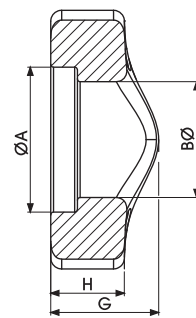
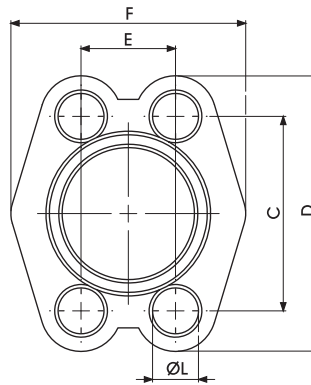

UNCUT SPLIT FLANGE S3000/CODE61 WITHOUT SCREW

TYPE	MAX PRESSURE	A	B	C	D	E	F	G	H	I	L	METRIC	UNC	WEIGHT Kg	ITEM CODE
1/2"	21 MPa	30,96	24,26	38,10	54	17,48	45,6	19	13	6,22	8,5	M8 X 25	5/16 X 1 1/4	0,135	C0077402Z
3/4"	21 MPa	38,89	32,13	47,63	65	22,23	51,8	22	14	6,22	10,5	M10 X 30	3/8 X 1 1/4	0,175	C0077502Z
1"	21 MPa	45,24	38,48	52,37	70	26,19	58,4	24	16	7,49	10,5	M10 X 35	3/8 X 1 1/4	0,23	C0077602Z
1 1/4"	21 MPa	51,59	43,69	58,72	79	30,18	72,6	22	16	7,49	12	M10 X 35	7/16 X 1 1/2	0,30	C0077702Z
1 1/2"	21 MPa	61,09	50,80	69,85	94	35,71	82,2	25	16	7,49	13,5	M12 X 35	1/2 X 1 1/2	0,475	C0077802Z
2"	21 MPa	72,24	64,74	77,77	102	42,88	96,4	26	16	9,02	13,5	M12 X 35	1/2 X 1 1/2	0,535	C0077902Z
2 1/2"	17.5 MPa	84,94	74,93	88,90	114	50,80	108,2	38	19	9,02	13,5	M12 X 40	1/2 X 1 1/2	0,78	C0078002Z
3"	13.8 MPa	102,39	90,93	106,38	135	61,93	130,6	41	22	9,02	16,75	M16 X 50	5/8 X 2	1,27	C0078102Z

UNCUT SPLIT FLANGE S6000/CODE62 WITHOUT SCREW

TYPE	MAX PRESSURE	A	B	C	D	E	F	G	H	I	L	METRIC	UNC	WEIGHT Kg	ITEM CODE
1/2"	42 MPa	32,54	24,64	40,49	56	18,24	47,2	22	16	7,24	8,5	M8 X 30	5/16 X 1 1/4	0,165	C0078202Z
3/4"	42 MPa	42,06	32,51	50,80	71	23,80	60	28	19	8,26	10,5	M10 X 35	3/8 X 1 1/2	0,325	C0078302Z
1"	42 MPa	48,41	38,86	57,15	81	27,76	69,9	33	24	9,02	13,5	M12 X 45	-	0,48	C0078402Z
1 1/4"	42 MPa	54,76	44,45	66,68	95	31,75	77,2	38	27	9,78	14,5	M12 X 50	1/2 X 1 3/4	0,73	C0078502Z
1 1/2"	42 MPa	64,29	51,56	79,38	113	36,50	95	43	30	12,07	16,75	M16 X 55	5/8 X 2	1,30	C0078602Z
2"	42 MPa	80,16	67,56	96,82	133	44,45	113,8	52	37	12,07	21	M20 X 65	3/4 X 2 1/2	1,95	C0078702Z
2 1/2"	42 MPa	108,90	90	123,80	180	58,80	150,2	45	45	20,50	26	M24 X 75	-	4,55	C0078802Z
3"	42 MPa	132,50	115	152,40	215	71,60	198,16	55	55	25,50	31	M30 X 90	-	8,25	C0078902Z

Flange

+ Limit switch

actuated valves

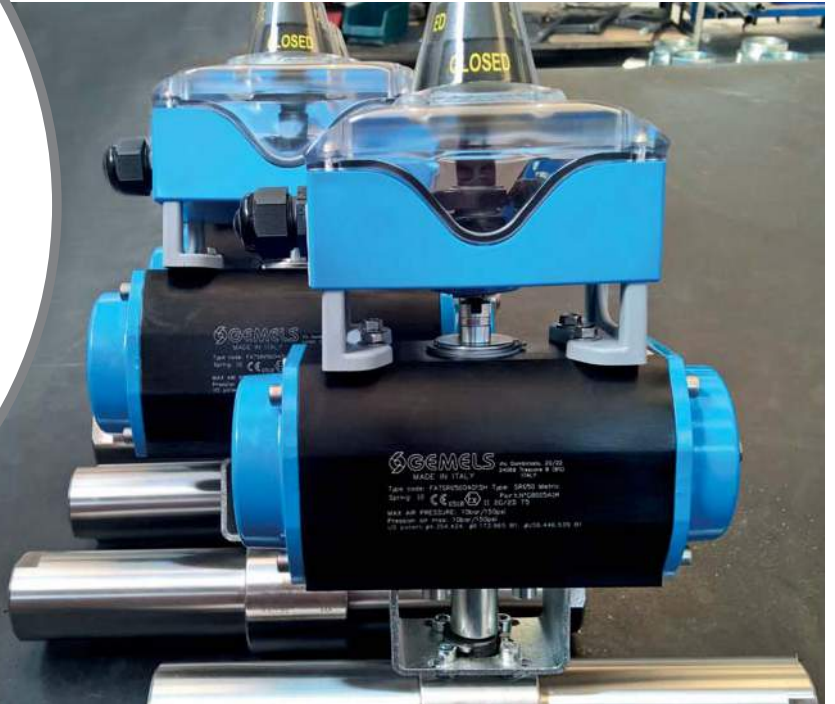

manual valves

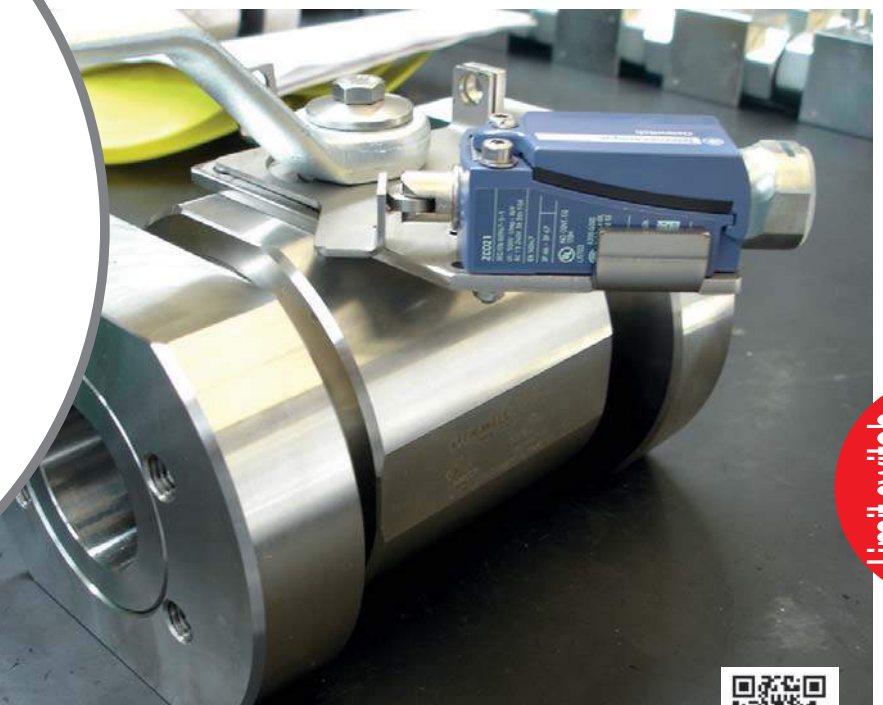

Limit switch



+ Actuated valves

Limit switch

Specialist in Ball Valves

- Compact and flexible limit switch box made of polyamide (PA6) with flat cover made of polycarbonate (PC)
- Adjustable polyamide mounting bracket (PA6) reinforced with 30% fiber glass for simple assembly on actuators according to VDI/VDE 3845:
Hole spacings: 80x30mm and 130x30mm
Shaft heights: 20 and 30mm
- Enclosure IP67 according to DIN EN 60529
- Cable gland M20x1,5 black (for cable Ø 6-12mm)
- Sealings EPDM and NBR, Screws AISI 304, Shaft polyamide PA6
- Application: Standard applications without explosive atmosphere.
1-4 mechanical switches or proximity sensors in V3 design,
1-3 slot type sensors,
1-2 cylindrical sensors Ø 8-18mm

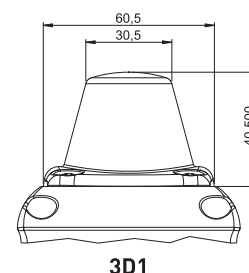
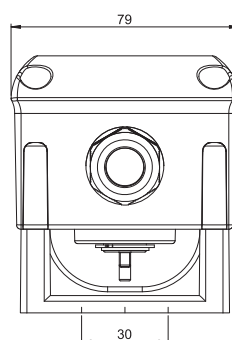
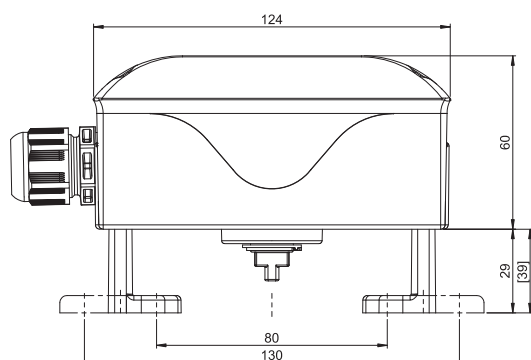

3D1

ACTUATOR CODE	DESCRIPTION	HOLES	SHAPT	MODEL	CODE
FATDA0250401SH	Actuator Double effect DA25 DN6-10-13 F03-F05	80X30	20	EPP2M01-020-3D1	FLSEPP2M01020HV
FATDA1000401SH	Actuator Double effect DA100 DN20-25 F05-F07	80X30	20	EPP2M01-020-3D1	FLSEPP2M01020HV
FATDA2000401SH	Actuator Double effect DA200 DN32-40 F05-F07	80X30	20	EPP2M01-020-3D1	FLSEPP2M01020HV
FATDA3750401SH	Actuator Double effect DA375 DN50-65 F07-F10-F12	80X30	20	EPP2M01-020-3D1	FLSEPP2M01020HV
FATDA8250401SH	Actuator Double effect DA825 DN80-100-125 F12	130X30	30	EPP2M03-020-3D1	FLSEPP2M03020HV
FATSR0250401SH	Actuator Simple effect SR25 DN6 DN10 F03-F05	80X30	20	EPP2M01-020-3D1	FLSEPP2M01020HV
FATSR0500401SH	Actuator Simple effect SR50 DN13 F05	80X30	20	EPP2M01-020-3D1	FLSEPP2M01020HV
FATSR1000401SH	Actuator Simple effect SR100 DN20-25 F05-F07	80X30	20	EPP2M01-020-3D1	FLSEPP2M01020HV
FATSR2000401SH	Actuator Simple effect SR200 DN32-40 F05-F07	80X30	20	EPP2M01-020-3D1	FLSEPP2M01020HV
FATSR3750401SH	Actuator Simple effect SR375 DN50-65 F07-F10-F12	80X30	20	EPP2M01-020-3D1	FLSEPP2M01020HV
FATSR6000401SH	Actuator Simple effect SR600 DN100 (LOW PRESSURE) F07-F12	130X30	30	EPP2M03-020-3D1	FLSEPP2M03020HV
FATSR8250401SH	Actuator Simple effect SR825 DN80-100-125 F10-F12	130X30	30	EPP2M03-020-3D1	FLSEPP2M03020HV

+ Actuated valves

Limit switch

www.gemels.it

TECHNICAL FEATURES

Producer switch	CROUZET
Switch type	83161.3
Voltage	250V
Maximum current	16A (250V AC), 2,5A (24V DC)
Contacts	Silber (Silver / Argento)
Temperature	-20°C ... +80°C

Connection

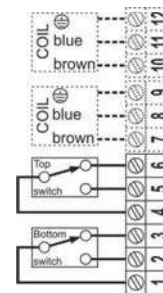

+ Manual valves

Limit switch

Specialist in Ball Valves

- Ambient air temperature:
 - operation: -25°C to +70°C
 - storage: -40°C to +70°C
- Vibration resistance: conforming to IEC 60068-2-6
- Shock resistance: conforming to IEC 60068-2-27
- Electric shock protection:
 - Class II conforming to IEC 61140 and NF C 20-030 for XCKP and XCKT
 - Class I conforming to IEC 61140 and NF C 20-030 for XCKD
- Degree of protection: IP66 and IP67 conforming to IEC 60529; IK4 conforming to EN50102 for XCKP and XCKT, IK06 conforming to EN50102 for XCKD
- Repeat accuracy: 0,1mm on the tripping points, with 1 milion operating cycles for head with end plunger
- Material: metal

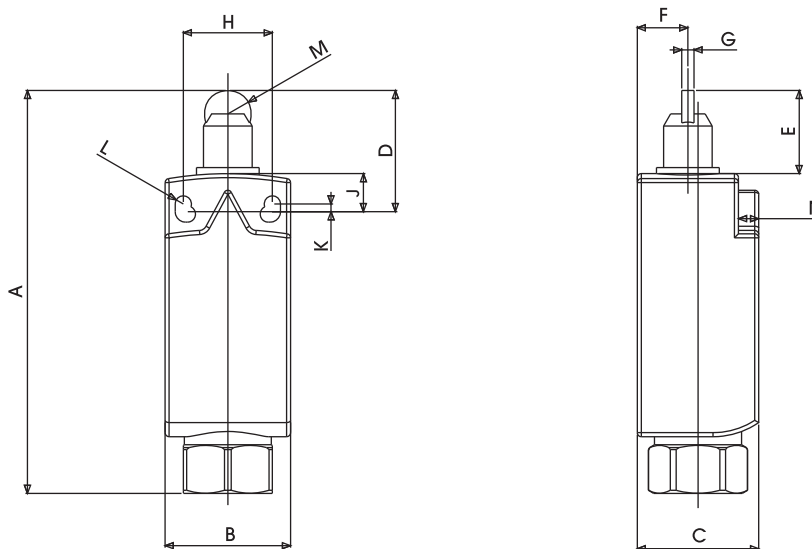
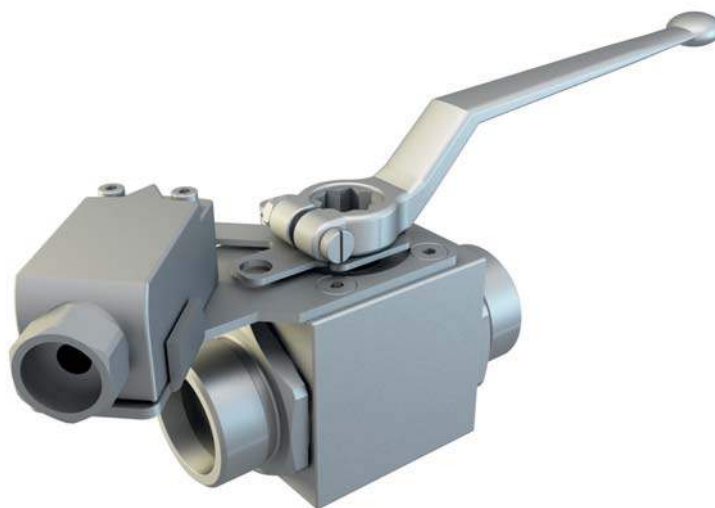

LIMIT SWITCH OSISWITCH METAL

TYPE	VOLTAGE	A	B	C	D	E	F	G	H	J	K	L	M	N	WEIGHT Kg	ITEM CODE
FLSXCKDZCE02HH	AC 15 240V 3A ITH 10A	99,55	31	30	30	20,6	12,5	3	22	9,41	1,91	2	5,8	5	0,164	FLSXCKDZCE02HH

+ Manual valves

Limit switch

www.gemels.it

LIMIT SWITCH OSISWITCH METAL KITS

CODE	BALL VALVES	DN
KOM00LS6EHH	GE - GV	DN6 DN10 DN13
KOM00LS6NHH	GN	DN6 DN10 DN13
KOM00LS20EHH	GE - GV	DN20 DN25
KOM00LS20NHH	GN	DN20 DN25
KOM00LS32BHH	GB - GV	DN32 DN40 DN50
KOM00LS32NHH	GN	DN32 DN40 DN50

STAINLESS STEEL KIT

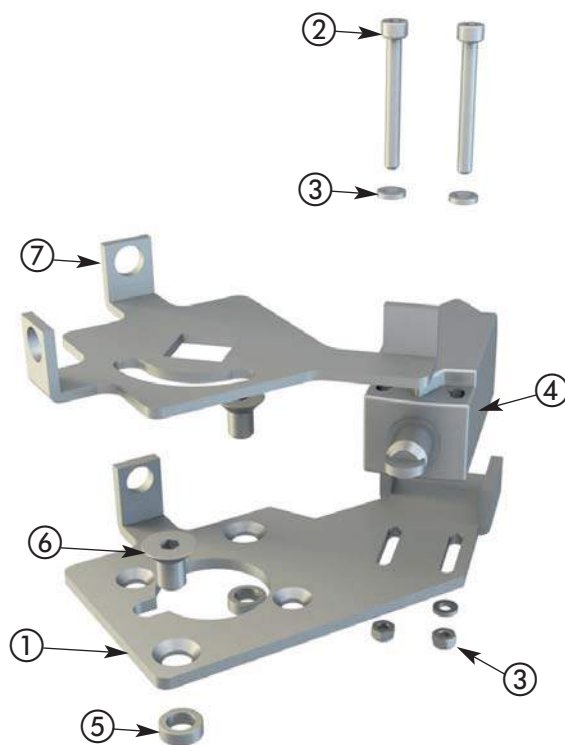

Pos	Description	Q.tà
1	Lower bracket	1
2	T.C.E.I. screw	2
3	Washer	4
4	Limit Switch Compact Metal	1
5	Nut	2
6	Screw	4
7	Top bracket	1

+ Manual valves

Limit switch

Specialist in Ball Valves

Universal, XCKD Metal

■ XCKD
with 1 cable entry
Conforming to CENELEC EN 50047

□ With head for linear movement (plunger). Mounting by the head or by the body.
XCK D



Environment characteristics

Conforming to standards	Products	IEC 60947-5-1, EN 60947-5-1, UL 508, CSA C22-2 n° 14
	Machine assemblies	IEC 60204-1, EN 60204-1
Product certifications		UL, CSA, CCC
Protective treatment	Standard version	"TC"
Ambient air temperature	Operation	- 25...+70 °C (-13...+158 °F)
	Storage	- 40...+70 °C (-40...+158 °F)
Vibration resistance	Conforming to IEC 60068-2-6	25 gn (10...500 Hz) except switch with head ZCE 24: 20 gn
Shock resistance	Conforming to IEC 60068-2-27	50 gn (11 ms) except heads ZCE08: 15 gn (11 ms) and ZCE24: 30 gn (18 ms)
Electric shock protection		Class I conforming to IEC 61140 and NF C 20-030 for XCKD
Degree of protection		IP 66 and IP 67 conforming to IEC 60529; IK 06 conforming to EN 50102 for XCKD
Repeat accuracy		0.1 mm on the tripping points, with 1 million operating cycles for head with end plunger
Cable entry or integral connector	Depending on model	Either: tapped entry for PG 11 or PG 13 conduit thread, tapped ISO M16 x 1.5 or ISO M20 x 1.5, tapped 1/2" NPT, tapped PF 1/2 (G1/2) or integral M12 connector
Materials		XCKD: Zamak® bodies and heads

Universal, XCKD-Complete Units with 1/2" NPT Cable Entry

Type of head **Plunger (mounting by the body)**

Form C (1)



Type of operator			Steel roller plunger		
------------------	--	--	----------------------	--	--

Catalog Numbers (2) (3)

<p>2-pole N/C + N/O snap action (XE2S P2151)</p>			<p>XCKD2102N12</p>		
--	--	--	--------------------	--	--

Characteristics

Switch actuation	On end	By 30° cam		
Type of actuation				
Maximum actuation speed	0,5 m/s (1,64 ft/s)			
Minimum force or torque	For tripping	15 N (3,37 lb)	12 N (2,70 lb)	
	For positive opening	45 N (10,12 lb)	36 N (8,09 lb)	
Cable entry (3)	1 entry tapped M16 x 1.5 mm for ISO cable entry, clamping capacity 4 to 8 mm (0.16 to 0.31 in.)			

- Form conforming to EN 50047, see page 20.
- Switches with gold contacts or ring type connections: please consult your local sales office.
- For an entry tapped for a PG 11 conduit thread, replace N12 in the catalog number with G11. Examples: XCKD2110N12 becomes XCKD2110G11, ZCDEN12 becomes ZCDEG11.

"The company reserves the right to operate dimensional changes without prior notice".

+ Manual valves

Limit switch

www.gemels.it

2015 - Edition 1

Universal, XCKD-Complete Units with 1/2" NPT Cable Entry

ZCD2• + ZCDEN12 / ZCD3• + ZCDEN12

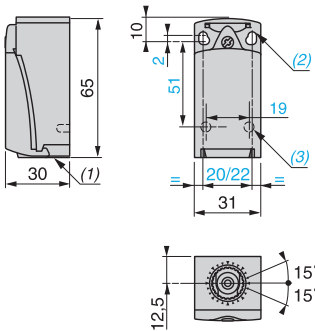

1. Tapped entry for ISO M16 x 1.5 or PG 11 conduit thread.
2. 2 elongated holes $\text{O} 4.3 \times 6.3 \text{ mm}$ ($0.17 \times 0.25 \text{ in.}$) on 22 mm (0.87 in.) centers, 2 holes $\text{O} 4.3 \text{ mm}$ (0.17 in.) on 20 mm (0.79 in.) centers.
3. $2 \times \text{O} 3$ holes for support studs, depth 4 mm (0.16 in.).
4. Mounting nut thickness 3.5 mm (0.14 in.).

ZCE02

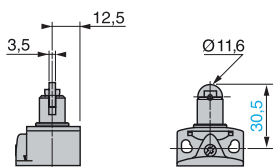

Universal, XCKD

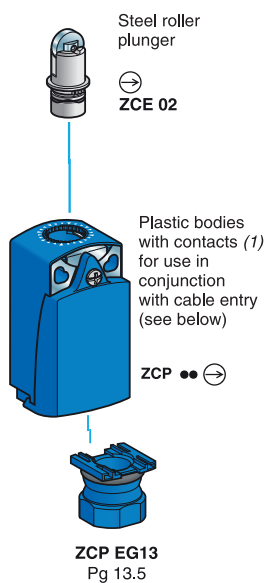

1. For further details, see page 70.
2. Cannot be used on bodies: ZCD21, ZCP21, ZCT21, ZCD29, ZCP29, ZCD31, ZCP31, ZCD39.ZCP39, ZCD2•M12, ZCP2•M12.

+ Electric Actuator

Specialist in Ball Valves



J3C ELECTRIC ACTUATOR

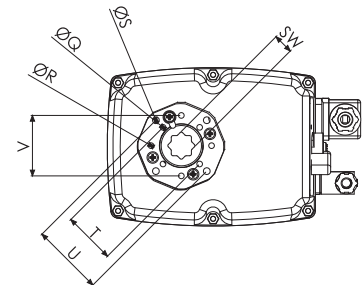
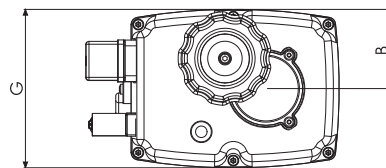
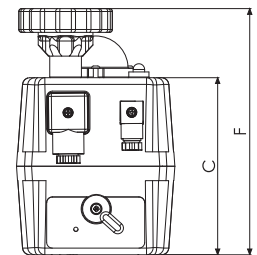
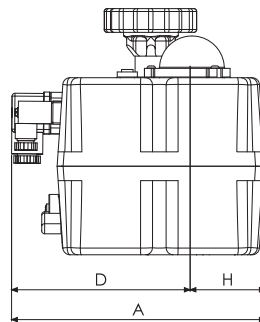

Technical data

- Housing:
Body and cover: anticorrosive polyamide
Main external shaft: stainless steel
- Fastening: stainless steel
- Gears: steel and polyamide
- Indicator: polyamide + glass filled
- Internal cams: polyamide + glass filled
- Electric motor: single phase
- Insulation: class B
- Duty range: 75%

All models options

- DPS2005 digital positioner: 0÷20mA, 4÷20mA o 0÷10V
- Digital potentiometer kit: 1K, 5K and 10K
- BSR battery fail safe kit
- 3 positions: 0° 45° 90° / 0° 90° 180°

VALVE WITH ELECTRICAL ACTUATORS

TYPE	BALL VALVES	DN
J3C-20	GE-GHP-GN	06-10
J3C-35	GE-GHP-GN-GR-SB	13

J3C ELECTRIC ACTUATOR

TYPE	VOLTAGE	ISO5211	A	B	C	D	F	G	H	Q	R	S	T	U	V	SW	Kg	ITEM CODE
J3C-L20	12 a 24 VAC/VDC	F03-F04-F05	177	55	123	126	171	110	51	M5	M5	M6	36	50	42	9 or 11 or 14	1,6	FAEJ3L2025HH
J3C-H20	85 to 240 VAC/VDC	F03-F04-F05	177	55	123	126	171	110	51	M5	M5	M6	36	50	42	9 or 11 or 14	1,6	FAEJ3H2025HH
J3C-L35	12 a 24 VAC/VDC	F03-F04-F05	177	55	123	126	171	110	51	M5	M5	M6	36	50	42	9 or 11 or 14	1,8	FAEJ3L3540HH
J3C-H35	85 to 240 VAC/VDC	F03-F04-F05	177	55	123	126	171	110	51	M5	M5	M6	36	50	42	9 or 11 or 14	1,8	FAEJ3H3540HH

	J3C-L-20	J3C-H-20	J3C-L-35	J3C-H-35
Voltage	12 a 24 VAC/VDC -0/+5%	85 to 240 VAC/VDC	12 a 24 VAC/VDC -0/+5%	85 to 240 VAC/VDC
Operation time unload	12 sec	11 sec	12 sec	11 sec
Maximum torque break	25N/m	25N/m	38N/m	38N/m
Maximum operational torque	20N/m	20N/m	35N/m	35N/m
Duty rating %	75,00%	75,00%	75,00%	75,00%
Working angle	90° TO 270°	90° TO 270°	90° TO 270°	90° TO 270°
Limit switch	4 SPDT micro	4 SPDT micro	4 SPDT micro	4 SPDT micro
Heater	3,5W	3,5W	3,5W	3,5W
Plugs	ISO440& C192	ISO440& C192	ISO440& C192	ISO440& C192
IP rating	IP-67	IP-67	IP-67	IP-67
Temperature	-20°C+70°C	-20°C+70°C	-20°C+70°C	-20°C+70°C
Consumption	24 VAC 787,5 mA 18,9W	110 VAC 168 mA 18,5W	24 VAC 1071 mA 25,7W	110 VAC 231 mA 25,4W
at maximum torque +/-5%	24 VDC 913,5 mA - 21,9W	220 VDC 84 mA - 18,5W	24 VDC 1491 mA - 35,8W	220 VDC 115,5 mA - 26,6W

"The company reserves the right to operate dimensional changes without prior notice".

+ Electric Actuator

Specialist in Ball Valves

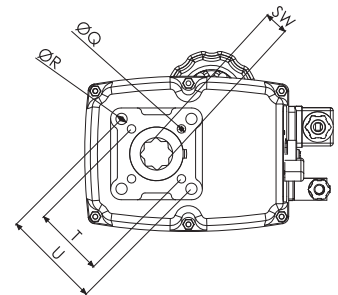
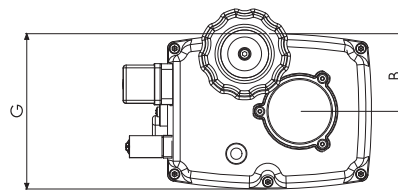
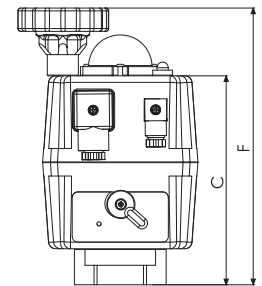
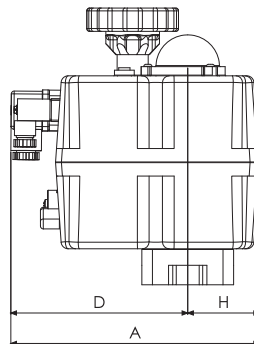

Technical data

- Housing:
Body and cover: anticorrosive polyamide
Main external shaft: stainless steel
- Fastening: stainless steel
- Gears: steel and polyamide
- Indicator: polyamide + glass filled
- Internal cams: polyamide + glass filled
- Electric motor: single phase
- Insulation: class B
- Service S4
- Duty range: 75%

All models options

- DPS2005 digital positioner: 0÷20mA, 4÷20mA o 0÷10V
- Digital potentiometer kit: 1K, 5K and 10K
- BSR battery fail safe kit
- 3 positions: 0° 45° 90° / 0° 90° 180°

VALVE WITH ELECTRICAL ACTUATORS

TYPE	BALL VALVES	DN
J3C-55	GE-GHP-GN-GR-SB	20
J3C-85	GE-GHP-GN-GR-SB	25

J3C ELECTRIC ACTUATOR

TYPE	VOLTAGE	ISO5211	A	B	C	D	F	G	H	Q	R	S	T	U	V	SW	Kg	ITEM CODE
J3C-L55	12 a 24 VAC/VDC	F05-F07	177	55	148	126	196	110	51	M5	M6	-	50	70	-	11 or 14 or 17	3	FAEJ3L5560HH
J3C-H55	85 to 240 VAC/VDC	F05-F07	177	55	148	126	196	110	51	M5	M6	-	50	70	-	11 or 14 or 17	3	FAEJ3H5560HH
J3C-L85	12 a 24 VAC/VDC	F05-F07	177	55	148	126	196	110	51	M5	M6	-	50	70	-	11 or 14 or 17	3	FAEJ3L8590HH
J3C-H85	85 to 240 VAC/VDC	F05-F07	177	55	148	126	196	110	51	M5	M6	-	50	70	-	11 or 14 or 17	3	FAEJ3H8590HH

	J3C-L-55	J3C-H-55	J3C-L-85	J3C-H-85
Voltage	12 a 24 VAC/VDC -0/+5%	85 to 240 VAC/VDC	12 a 24 VAC/VDC -0/+5%	85 to 240 VAC/VDC
Operation time unload	16 sec	14 sec	35 sec	30 sec
Maximum torque break	60N/m	60N/m	90N/m	90N/m
Maximum operational torque	55N/m	55N/m	85N/m	85N/m
Duty rating %	75,00%	75,00%	75,00%	75,00%
Working angle	90° TO 270°	90° TO 270°	90° TO 270°	90° TO 270°
Limit switch	4 SPDT micro	4 SPDT micro	4 SPDT micro	4 SPDT micro
Heater	3,5W	3,5W	3,5W	3,5W
Plugs	ISO440& C192	ISO440& C192	ISO440& C192	ISO440& C192
IP rating	IP-67	IP-67	IP-67	IP-67
Temperature	-20°C+70°C	-20°C+70°C	-20°C+70°C	-20°C+70°C
Consumption	24 VAC 1239 mA 29,7W	110 VAC 231 mA 25,4W	24 VAC 934,5 mA 22,4W	110 VAC 168 mA 18,5W
at maximum torque +/-5%	24 VDC 1428 mA - 34,3W	220 VDC 105 mA - 23,1W	24 VDC 1176 mA - 28,2W	220 VDC 84 mA - 18,5W

"The company reserves the right to operate dimensional changes without prior notice".

+ Electric Actuator

www.gemels.it

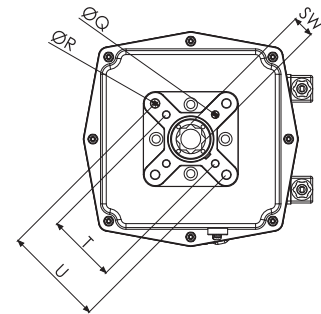
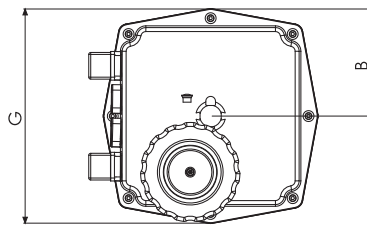
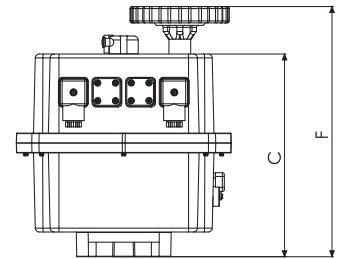
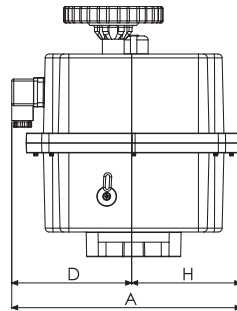

Technical data

- Housing:
Body and cover: anticorrosive polyamide
Main external shaft: stainless steel
- Fastening: stainless steel
- Gears: steel and polyamide
- Indicator: polyamide + glass filled
- Internal cams: polyamide + glass filled
- Electric motor: single phase
- Insulation: class B
- Service S4
- Duty range: 75%

All models options

- DPS2005 digital positioner: 0÷20mA, 4÷20mA o 0÷10V
- Digital potentiometer kit: 1K, 5K and 10K
- BSR battery fail safe kit
- 3 positions: 0° 45° 90° / 0° 90° 180°

VALVE WITH ELECTRICAL ACTUATORS

TYPE	BALL VALVES	DN
J3-140	GB-GHP-GN-GR-SB	32-40
J3-300	GB-GHP-GN-GR-SB	50

J3C ELECTRIC ACTUATOR

TYPE	VOLTAGE	ISO5211	A	B	C	D	F	G	H	Q	R	S	T	U	V	SW	Kg	ITEM CODE
J3-L140	12 a 48 VAC/VDC	F07-F10	235	107	205	128	254	214	107	M6	M8	-	70	102	-	17 or 22	5,2	FAEJ3L140170HH
J3-H140	80 to 240 VAC/VDC	F07-F10	235	107	205	128	254	214	107	M6	M8	-	70	102	-	17 or 22	5,2	FAEJ3H140170HH
J3-L300	12 a 48 VAC/VDC	F07-F10	235	107	205	128	254	214	107	M6	M8	-	70	102	-	17 or 22	5,2	FAEJ3L300350HH
J3-H300	80 to 240 VAC/VDC	F07-F10	235	107	205	128	254	214	107	M6	M8	-	70	102	-	17 or 22	5,2	FAEJ3H300350HH

	J2-L140	J2-H140	J2-L300	J2-H300
Voltage	12 a 48 VAC/VDC -0/+5%	80 to 240 VAC/VDC	12 to 48 VAC/VDC -0/+5%	80 to 240 VAC/VDC
Operation time unload	33 sec	33 sec	60 sec	60 sec
Maximum torque break	140N/m	140N/m	300N/m	300N/m
Maximum operational torque	170N/m	170N/m	350N/m	350N/m
Duty rating %	75,00%	75,00%	75,00%	75,00%
Working angle	90° 180° 270°	90° 180° 270°	90° 180° 270°	90° TO 270°
Limit switch	4 SPDT micro	4 SPDT micro	4 SPDT micro	4 SPDT micro
Heater	4W	4W	4W	4W
Plugs	ISO440& C192	ISO440& C192	ISO440& C192	ISO440& C192
IP rating	IP-65	IP-65	IP-65	IP-65
Temperature	-20°C+70°C	-20°C+70°C	-20°C+70°C	-20°C+70°C
Consumption at maximum torque +/-5%	24 VAC 3600 mA 86,4W 24 VDC 3000 mA - 72W 48 VAC 1300 mA 62,4W 48 VDC 1000 mA 48W	110 VAC 700 mA 77W 220 VDC 230 mA - 50,6W 48 VAC 1300 mA 62,4W 48 VDC 1000 mA 48W	24 VAC 3600 mA 86,4W 24 VDC 3000 mA - 72W 220 VDC 230 mA - 50,6W	110 VAC 700 mA 77W

Actuators

+ Electric Actuator

Specialist in Ball Valves

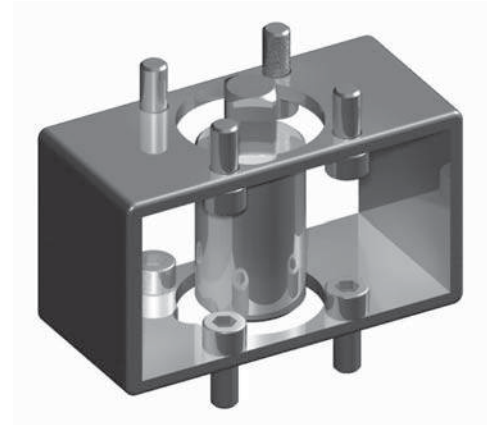
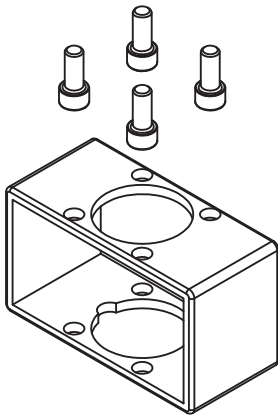

KITS WASHER
 ONLY FOR GN-GB VALVES -KIT ACTUATOR
 C0034406H FOR DN6-DN10-DN13-DN20-DN25-DN32
 C0034306H FOR DN40-DN50

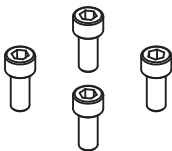
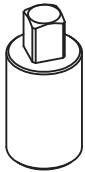

SR ACTUATORS KITS

TYPE	BALL VALVES	DN	MATERIAL	ISO5211	WHEIGHT Kg	ITEM CODE
AK65	SB	65-80	CARBON STEEL	F05 F07-F05	0,74	KOC00AK651X
AK32	SB	32-40	CARBON STEEL	F05 F07-F05	0,60	KOC00AK321X
AK40	GB-GHP-GN-GR-SB	32-40	CARBON STEEL	F05 F07-F05	0,67	KOC00AK401X
AK20	GE-GB-GHP-GN-GR-SB	20-25	CARBON STEEL	F05 F07-F05	0,52	KOC00AK201X
AK6	GE-GHP-GN-GR-SB	06-10-13	CARBON STEEL	F03-F03	0,25	KOC00AK61X
AK13	GE-GHP-GN-GR	13	CARBON STEEL	F03-F05	0,31	KOC00AK131X
AK100	GR-SB	100-125	CARBON STEEL	F10 F12-F12	2,05	KOC00AK1001X
AK50	GB-GHP-GN-GR-SB	50	CARBON STEEL	F05 F07-F05	0,71	KOC00AK501X
AK6S	GN	06-10-13	CARBON STEEL	F03 F05-F03 F05	0,30	KOC00AK6S1X

+ Electric Actuator

www.gemels.it

2014 - Edition 2

Technical data

- The LED status Light provides visual communication between the actuator and the user
- The current operational status is shown by either solidly lit, or different flashing sequences of the LED light:
 - TIME 200 mSec X each digit of the configuration
 - Configuration digit 1 = LED on digit 0 = LED off
- The configuration is a repetitive sequence of 4 columns of 4 digits

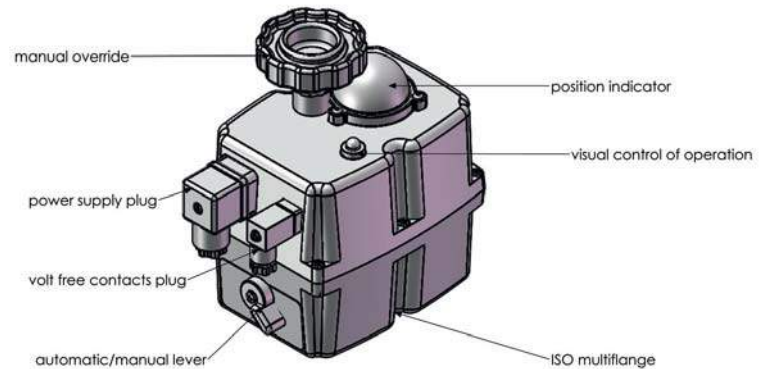

EXTERNAL ELECTRIC WIRING ON-OFF

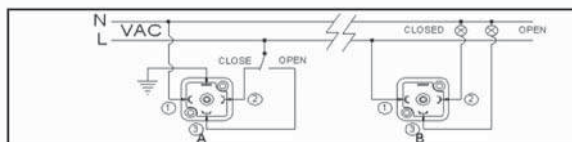

EXTERNAL ELECTRIC WIRING ON-OFF

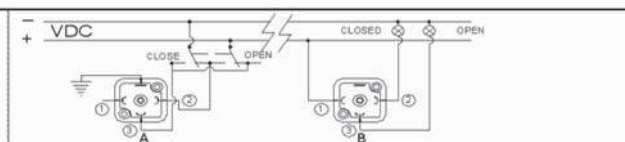

- A = power supply plug
VAC 3 WIRES (grey plug)
PIN 1 = Neutral + PIN 2= Phase = Close
PIN 1 = Neutral + PIN 3 = Phase = Open
- B = Volt free contacts plug
PIN 1 PIN 2 = Closed
PIN 1 PIN 3 = Open

- A = power supply plug
VAC 3 WIRES (grey plug)
PIN 1 = Neutral + PIN 2= Phase = Close
PIN 1 = Neutral + PIN 3 = Phase = Open
- B = Volt free contacts plug
PIN 1 PIN 2 = Closed
PIN 1 PIN 3 = Open

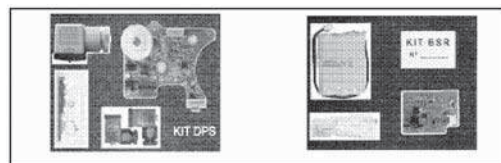
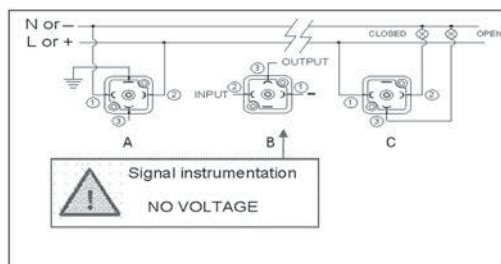

UPON REQUEST

- EXTERNAL ELECTRIC WIRING POSITIONER
 - A = Power supply plug
A = VAC 2 WIRES (grey plug)
PIN 1 = neutral or (-) + PIN 2 or (+) = Power supply plug
 - B = Signal instrumentation
B = input signal: 4/20mA or 0/10V
output signal: 4/20mA or 0/10V
PIN 1 = (-) Negative + PIN 2 = (+) positive = input signal
PIN 1 = (-) Negative + PIN 3 = (+) positive = output signal
 - C = Volt free contacts plug
C = PIN 1 / PIN 2 = closed
PIN 1 / PIN 3 = open

FLASHING LED	TIME	CONFIGURATION
Actuator without power being supplied	100%	0000 0000 0000 0000
Actuator with power being supplied	100%	1111 1111 1111 1111
Actuator with torque limiter activated	200 mSeg	1010 1010 1010 1010
Actuator without power working with the BSR system Max 3 minutes	200 mSeg	1000 0000 0000 0000
Actuator in MANUAL mode	200 mSeg	1111 0111 1000 0000
Actuator in MANUAL mode but with an internal cam operating an internal switch	200 mSeg	1110 1111 1111 1110
Positioner malfunction	200 mSeg	1101 1011 0000 0000
Battery protection. Danger the battery needs recharging BSP blocked	200 mSeg	1010 1000 0000 0000

Actuators

+ Actuators

Specialist in Ball Valves



ACTUATORS DA

Basic Operating Details

- Port "A" Air to open (anti clockwise)
- Port "B" Air to close (clockwise)
- Air supply: 6 bar; maximum 7 bar
- Drive Medium = Air (Dry or lubricated); not corrosive Gas; light hydraulic oil
- Temperature= Buna nitrile o'seals -40° to 80°C or -40 to 176° F
- Standard indicator position

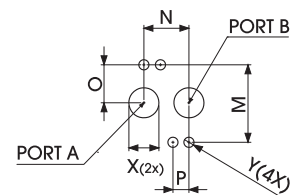

Solenoid mounting for all actuators

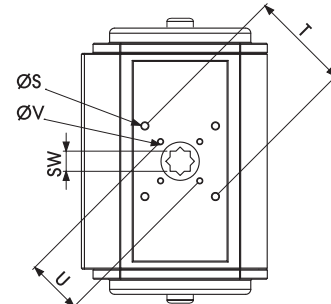
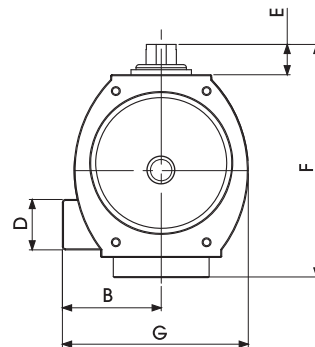
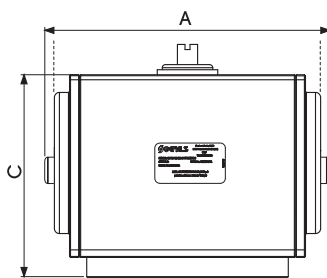

DA ACTUATORS (double acting)

TYPE	ISO5211	A	B	C	D	E	F	G	M	N	O	P	ØS	T	ØV	U	X	Y	SW	WEIGHT Kg	ITEM CODE
DA25	F03-F05	160	38	70	40	20	90	69,5	32	24	16	12	M6	50	M5	36	G _{1/8} x12	M5X8	9	1	FATDA0250401SH
DA100	F05-F07	222,5	59	118	43	20	138	113	32	24	16	12	M8	70	M6	50	G _{1/8} x12	M5X8	14	2,8	FATDA1000401SH
DA200	F05-F07	238	72	140,5	43	20	160,5	136,5	32	24	16	12	M8	70	M6	50	G _{1/4} x12	M5X8	17	7,0	FATDA2000401SH
DA375	F07-F10	286	78	166,5	43	30	196,5	156	32	24	16	12	M10	102	M8	70	G _{1/4} x12	M5X8	22	10,5	FATDA3750401SH
DA825	F10-F12	360	95,5	207,5	43	30	237,5	191	32	24	16	12	M12	125	M10	102	G _{1/4} x12	M5X8	27	22,4	FATDA8250401SH

VALVES WITH DA ACTUATORS

TYPE	BALL VALVES	DN
DA25	GE-GHP-GN-GR-SB	06-10-13
DA100	GE-GHP-GN-GR-SB	20-25
DA200	GB-GHP-GN-GR-SB	32-40
DA375	GB-GHP-GN-GR-SB	50-65
DA825	GR-SB	80-100-125

DA ACTUATORS TORQUE MOMENT

TYPE	AIR SUPPLY	N/m
DA25	6 BAR	23,7
DA100	6 BAR	101,5
DA200	6 BAR	201,9
DA375	6 BAR	374
DA825	6 BAR	824

+ Actuators

Specialist in Ball Valves

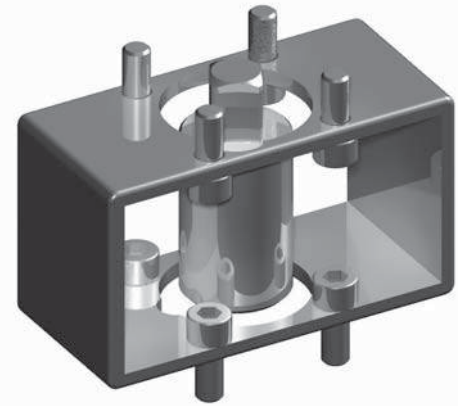
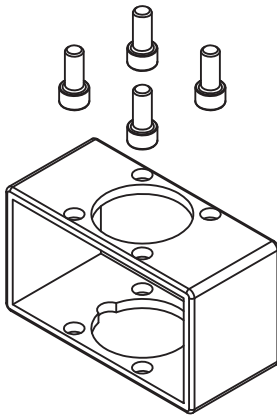

KITS WASHER
 ONLY FOR GN-GB VALVES -KIT ACTUATOR
 C0034406H FOR DN6-DN10-DN13-DN20-DN25-DN32
 C0034306H FOR DN40-DN50

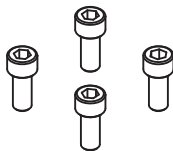
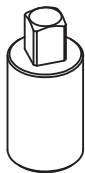

DA ACTUATORS KITS

TYPE	BALL VALVES	DN	MATERIAL	ISO5211	WHEIGHT Kg	ITEM CODE
AK65	SB	65-80	CARBON STEEL	F05 F07-F05	0,74	KOC00AK651X
AK32	SB	32-40	CARBON STEEL	F05 F07-F05	0,60	KOC00AK321X
AK40	GB-GHP-GN-GR-SB	32-40	CARBON STEEL	F05 F07-F05	0,67	KOC00AK401X
AK20	GE-GB-GHP-GN-GR-SB	20-25	CARBON STEEL	F05 F07-F05	0,52	KOC00AK201X
AK6	GE-GHP-GN-GR-SB	06-10-13	CARBON STEEL	F03-F03	0,25	KOC00AK61X
AK13	GE-GHP-GN-GR	13	CARBON STEEL	F03-F05	0,31	KOC00AK131X
AK100	GR-SB	100-125	CARBON STEEL	F10 F12-F12	2,05	KOC00AK1001X
AK50	GB-GHP-GN-GR-SB	50	CARBON STEEL	F05 F07-F05	0,71	KOC00AK501X
AK6S	GN	06-10-13	CARBON STEEL	F03 F05-F03 F05	0,30	KOC00AK6S1X

+ Actuators

www.gemels.it



ACTUATORS SR

Basic Operating Details

- Port "A" Air to open (anti clockwise compressing spring)
- Port "B" Spring to close (clockwise)
- Air supply: 6 bar; maximum 7 bar
- Drive Medium = Air (Dry or lubricated); not corrosive Gas; light hydraulic oil
- Temperature = Buna nitrile o'seals -40° to 80°C or -40° to 176° F
- Standard indicator position

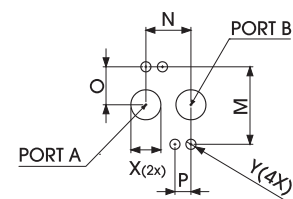

Solenoid mounting for all actuators

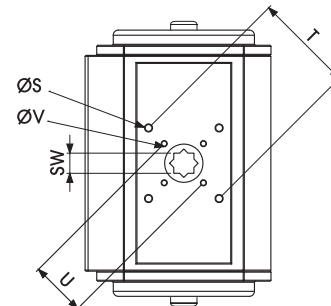
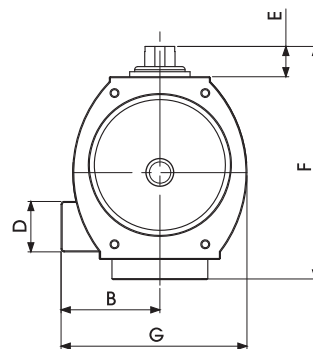
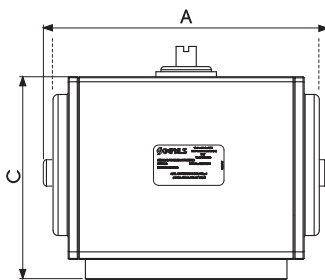

SR ACTUATORS (spring return)

TYPE	IS05211	A	B	C	D	E	F	G	M	N	O	P	ØS	T	ØV	U	X	Y	SW	WEIGHT Kg	ITEM CODE
SR25	F03-F05	160	38	70	40	20	90	69,5	32	24	16	12	M6	50	M5	36	G1/8 x12	M5x8	9	1	FATSR0250401SH
SR50	F05-F07	203	49	87	40	20	107	90,5	32	24	16	12	M8	70	M6	50	G1/8 x12	M5x8	11	1,9	FATSR0500401SH
SR100	F05-F07	222,5	59	118	43	20	138	113	32	24	16	12	M8	70	M6	50	G1/8 x12	M5x8	14	2,8	FATSR1000401SH
SR200	F07-F10	238	72	140,5	43	20	160,5	136,5	32	24	16	12	M8	102	M6	70	G1/4 x12	M5x8	17	7	FATSR2000401SH
SR375	F07-F10	286	78	166,5	43	30	196,5	156	32	24	16	12	M10	102	M8	70	G1/4 x12	M5x8	22	10,5	FATSR3750401SH
SR600	F10-F12	334	95,5	207,5	43	30	237,5	191	32	24	16	12	M12	125	M10	102	G1/4 x12	M5x8	27	20,6	FATSR6000401SH
SR825	F10-F12	360	95,5	207,5	43	30	237,5	191	32	24	16	12	M12	125	M10	102	G1/4 x12	M5x8	27	22,4	FATSR8250401SH

VALVES WITH SR ACTUATORS

TYPE	BALL VALVES	DN
SR25	GE-GHP-GN-GR-SB	06-10
SR50	GE-GHP-GN-GR-SB	13
SR50	GN	06-10-13
SR100	GE-GB-GHP-GN-GR-SB	20-25
SR200	GB-GHP-GN-GR-SB	32-40
SR375	GB-GHP-GN-GR-SB	50-65
SR600	GB-GHP-GN-GR-SB	80-100 (LOW PRESSURE)
SR825	GR-SB	80-100-125

SR ACTUATORS TORQUE MOMENT

TYPE	AIR SUPPLY	AIR-START N/m	AIR-END N/m	SPRING-START N/m	SPRING-END N/m	N°SPRING
SR25	6 BAR	16,3	9,3	14,41	7,37	11
SR50	6 BAR	32,7	18,1	32,64	18	12
SR100	6 BAR	61,4	40,1	61,3	40	12
SR200	6 BAR	130,33	71,73	130,2	71,6	4X4
SR375	6 BAR	241,54	132,98	241,2	132,64	4X4
SR600	6 BAR	385,20	212,1	384,6	211,5	4X4
SR825	6 BAR	533	294	531	292	4X4

Actuators

+ Actuators

Specialist in Ball Valves

2016 - Edition 1

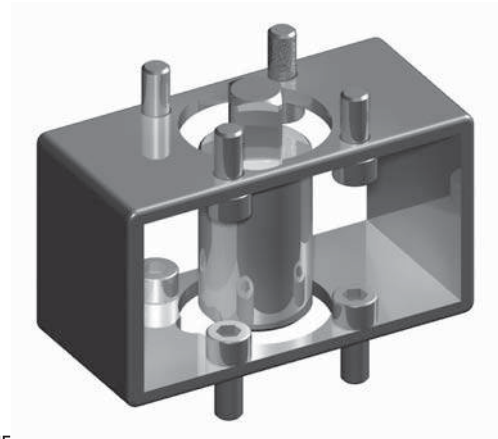
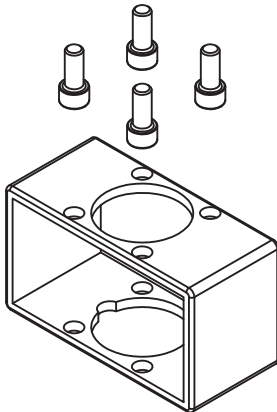

KITS WASHER
 ONLY FOR GN-GB VALVES -KIT ACTUATOR
 C0034406H FOR DN6-DN10-DN13-DN20-DN25-DN32
 C0034306H FOR DN40-DN50

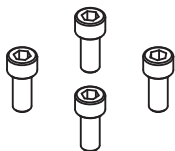
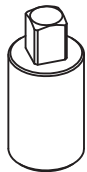

SR ACTUATORS KITS

TYPE	BALL VALVES	DN	MATERIAL	ISO5211	WHEIGHT Kg	ITEM CODE
AK65	SB	65-80	CARBON STEEL	F05 F07-F05	0,74	KOC00AK651X
AK32	SB	32-40	CARBON STEEL	F05 F07-F05	0,60	KOC00AK321X
AK40	GB-GHP-GN-GR-SB	32-40	CARBON STEEL	F05 F07-F05	0,67	KOC00AK401X
AK20	GE-GB-GHP-GN-GR-SB	20-25	CARBON STEEL	F05 F07-F05	0,52	KOC00AK201X
AK6	GE-GHP-GN-GR-SB	06-10-13	CARBON STEEL	F03-F03	0,25	KOC00AK61X
AK13	GE-GHP-GN-GR	13	CARBON STEEL	F03-F05	0,31	KOC00AK131X
AK100	GR-SB	100-125	CARBON STEEL	F10 F12-F12	2,05	KOC00AK1001X
AK50	GB-GHP-GN-GR-SB	50	CARBON STEEL	F05 F07-F05	0,71	KOC00AK501X
AK6S	GN	06-10-13	CARBON STEEL	F03 F05-F03 F05	0,30	KOC00AK6S1X

+ Actuators

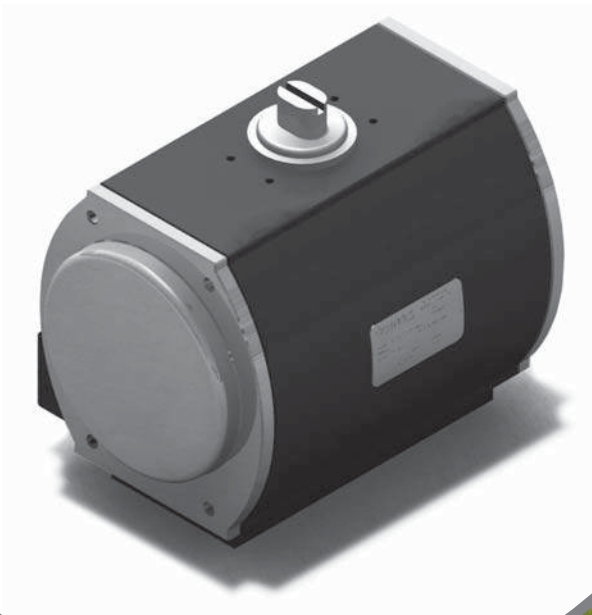

GEMELS PNEUMATIC ACTUATORS

**INSTALLATION, OPERATION
AND MAINTENANCE
TECHNICAL DETAILS**
Quarter-Turn Rack & Pinion

Actuators

+ Actuators

Specialist in Ball Valves

Introduction

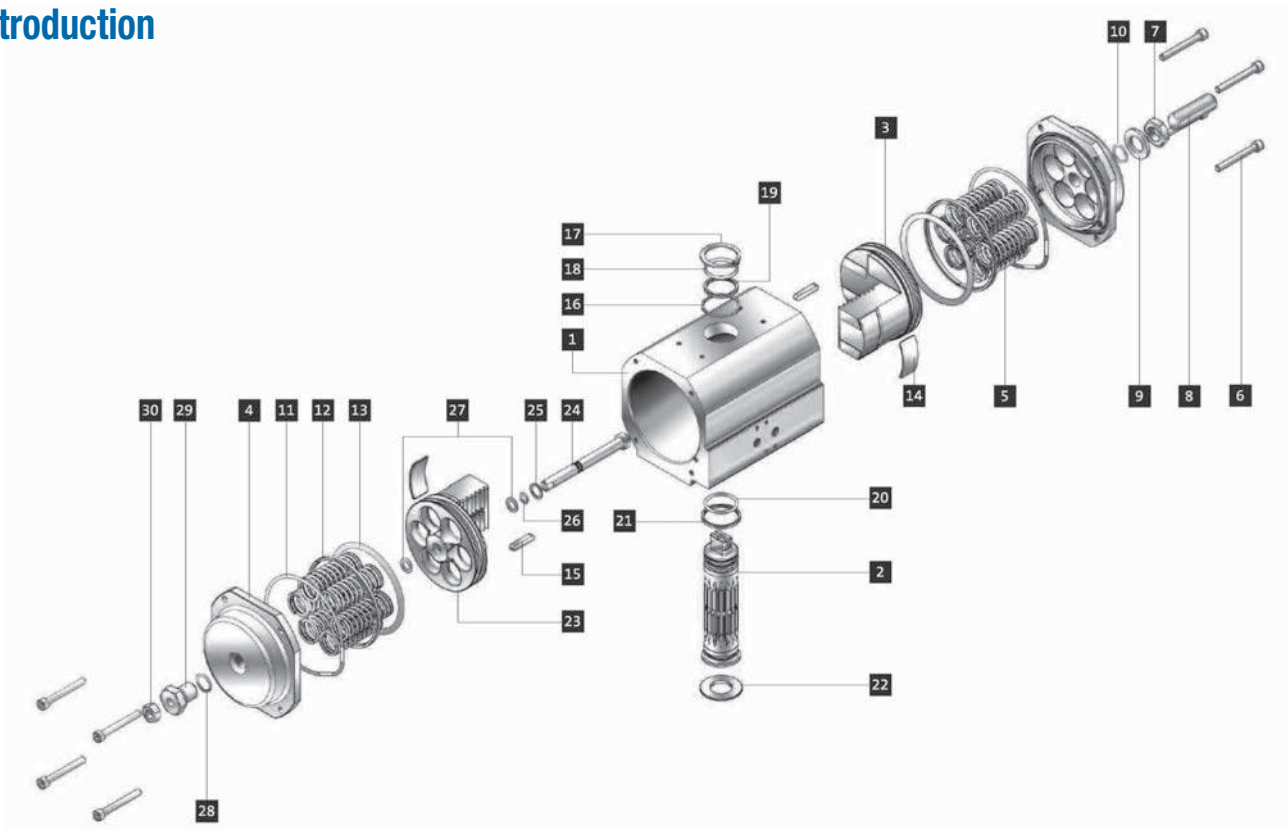

STANDARDS

Gemels actuators are designed and in compliance with the following standards:

- ISO5211:** Orientation of actuator to valvemounting flange (i.e.F05,F07....)
- VDI/VDE 3845:** Namur mounting for accessories such as switchboxes, solenoid valves and positioners.
- ATEX:** ATEX Directive (94/9/CE).
- PED:** Pressure Equipment Directive (97/23/CE).

Ref No	Description	Qty	Material Std Unit	Comments
1	Body	1	Aluminium Anod.	
2	Driveshaft	1	Steel	Alt. CNI 425
3	Piston	2	Aluminium	Alt. Hard Anodized/PTFE
4	Endcap with Stop Adj.	2	Aluminium Anod.	
5	Spring	12 max	SiCr	S1 Double Acting only
6	Endcap Bolt	8	Stainless Steel	
7	Open Stop Adj. Bolt	1	Stainless Steel	
8	Open Stop Adj. Nut	1	Stainless Steel	
9	Open Stop Adj. Washer	1	Polyethylene	
10	Open Stop Adj. O'Ring	1	Buna Nitrile	Alt. Viton/Silicone/EPDM
11*	Endcap O'Ring	2	Buna Nitrile	Alt. Viton/Silicone/EPDM
12*	Piston Back-up Bearing	2	POM Delrin	
13*	Piston O'Ring	2	Buna Nitrile	Alt. Viton/Silicone/EPDM
14*	Piston Wearpad	2	POM Delrin	
15*	Piston Guidebar	2	Steel	
16*	Driveshaft Washer	1	Polyethylene	
17*	Driveshaft Circlip	1	Steel	
18*	Driveshaft Upper O'Ring	1	Buna Nitrile	Alt. Viton/Silicone/EPDM
19*	Driveshaft Upper Bearing	1	POM Delrin	
20*	Driveshaft Lower O'Ring	1	Buna Nitrile	Alt. Viton/Silicone/EPDM
21*	Driveshaft Lower Bearing	1	POM Delrin	
22	Centralization Ring	1	POM Delrin	
23 (G10)	Piston (Closed Stop Adj.)	1	Aluminium	Alt. Hard Anodized/PTFE
24 (G10)	Closed Stop Adj. Bolt	1	Stainless Steel	
25 (G10)	Closed Stop Adj. Damper	1	POM Delrin	
26 (G10)	Stop Bolt O'Ring	1	Buna Nitrile	Alt. Viton/Silicone/EPDM
27 (G10)	Piston Stop Bolt O'Ring	2	Buna Nitrile	Alt. Viton/Silicone/EPDM
28 (G10)	Stop Bolt Retainer O'Ring	1	Buna Nitrile	Alt. Viton/Silicone/EPDM
29 (G10)	Stop Bolt Retainer	1	Stainless Steel	
30 (G10)	Closed Stop Adj. Nut	1	Stainless Steel	

The company reserves the right to operate dimensional changes without prior notice.

+ Actuators

Specialist in Ball Valves

Double Acting

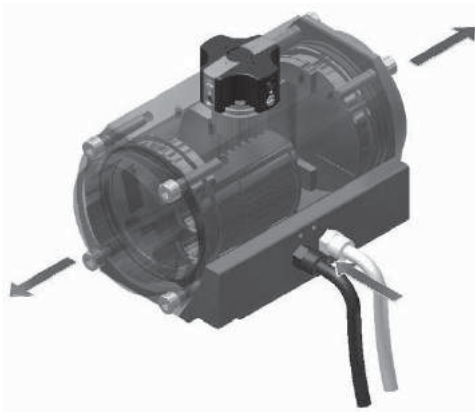

Opening Stroke:

- Looking at the front of the Actuator, PORT 'A' is on the left and PORT 'B' is on the right.
- To open the Actuator, connect the air supply to PORT 'A' to fill the central chamber of the Actuator.
- The two opposing Pistons will open and rotate the driveshaft in a counter-clockwise direction.
- When the pistons reach the end of their travel, the actuator driveshaft will be in the open position.

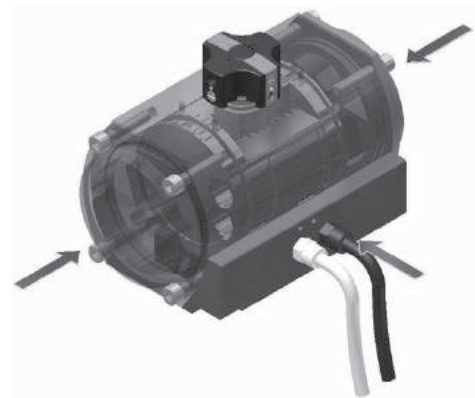

Closing Stroke:

- Looking at the front of the Actuator, PORT 'A' is on the left and PORT 'B' is on the right.
- To close the Actuator, connect the air supply to PORT 'B' to fill the outer chambers of the Actuator
- The two opposing Pistons will close and rotate the actuator driveshaft in a clockwise direction.
- When the pistons reach the end of their travel, the actuator driveshaft will be in the closed position.

+ Actuators

Torque Value Gemels Actuators

Double Acting

Torque Diagram Double Acting Actuator

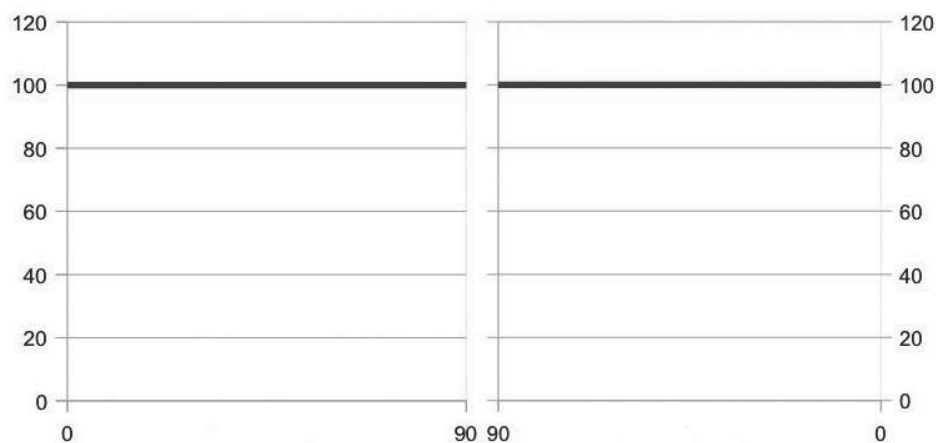

With reference to the above diagram, is possible to note that the torque of a double acting actuator remain constant through-out the complete action.

Newton Metre

Actuator	AIR SUPPLY (Barg)						
	2	3	4	5	5,5	6	7
DA25 GD A3	7,9	11,9	15,8	19,8	21,7	23,7	27,7
DA100 GD A10	33,8	50,7	67,6	84,5	93,0	101,4	118,3
DA375 GD A35	125,0	187,0	249,0	312,0	343,0	374,0	437,0
DA825 GD A70	275,0	412,0	550,0	687,0	756,0	825,0	962,0

+ Actuators

Specialist in Ball Valves

Spring Return

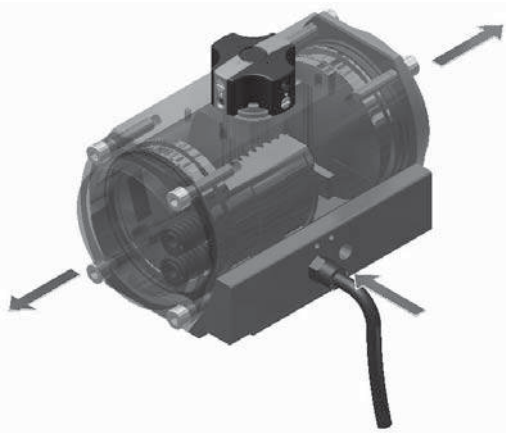

Opening Stroke:

- Looking at the front of the Actuator, PORT 'A' is on the left and PORT 'B' is on the right.
- To open the Actuator, connect the air supply to PORT 'A' to fill the central chamber of the Actuator.
- The two opposing Pistons will open, compressing the springs in the outer chambers and rotate the driveshaft in a counter-clockwise direction.
- When the pistons reach the end of their travel, the springs will be fully compressed and the actuator driveshaft will be in the open position.

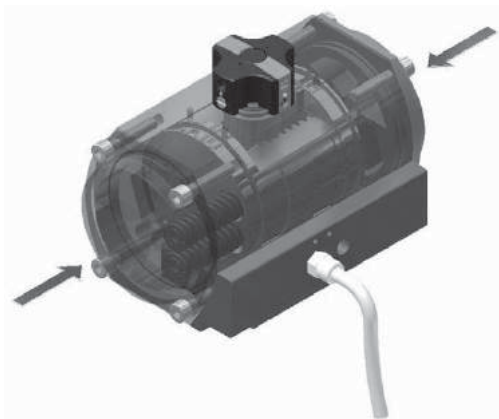

Closing Stroke:

- Looking at the front of the Actuator, PORT 'A' is on the left and PORT 'B' is on the right.
- To close the Actuator, disconnect the air supply from PORT 'A'. This will allow the compressed springs to push the pistons back to their starting position.
- As the springs decompress the two opposing Pistons will close and rotate the actuator driveshaft in a clockwise direction.
- When the pistons reach the end of their travel, the actuator driveshaft will be in the closed position.

+ Actuators

Torque Value Gemels Actuators

Spring Return

0 Torque Diagram Spring Return actuator

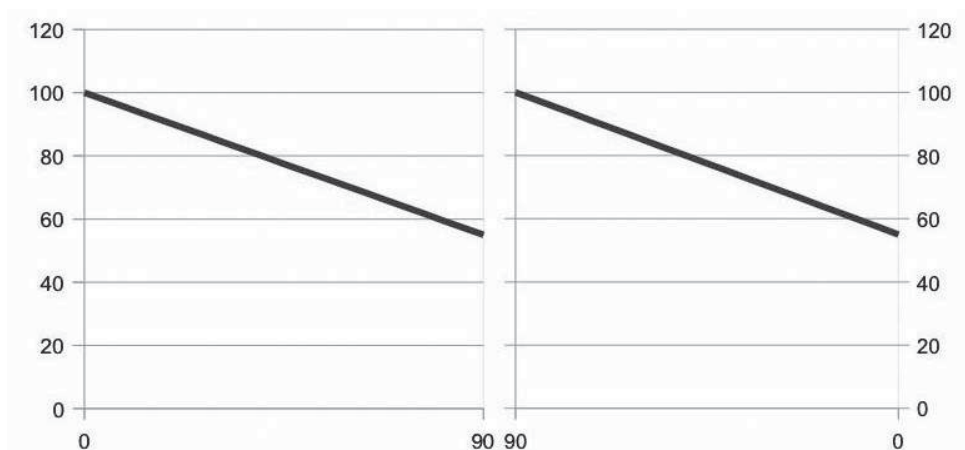

With reference to the above diagram the torque of a Spring Return actuator is not constant but decreasing. This is due to the action of the springs.

Model	N.Spring		Spring Torque		AIR SUPPLY (Barg)							
	Outer	Inner	0°	90°	4 Barg		5 Barg		5,5 Barg		6 Barg	
					90°	0°	90°	0°	90°	0°	90°	0°
SR25 TT3	8		5,36	10,48	10,40	5,30	14,40	9,30	16,40	11,20	18,30	13,20
	10		6,70	13,10			13,10	6,70	15,00	8,60	17,00	10,60
	11		7,37	14,41					14,40	7,30	16,30	9,30
	12		8,04	15,72					13,70	6,00	15,70	8,00
SR100 TT10	8		26,72	40,96	40,90	26,60	57,80	43,50	66,20	52,00	74,70	60,40
	10		33,40	51,20			51,10	33,30	59,60	41,80	68,00	50,20
	11		36,74	56,32					56,20	36,60	64,70	45,10
	12		40,08	61,44					52,90	31,50	61,30	40,00
SR375 TT35	4	0	88,40	160,80	161,00	88,70	223,40	151,00	254,60	182,20	285,70	213,40
	4	2	110,50	201,00	138,90	48,50	201,30	110,80	232,50	142,00	263,60	173,20
	4	3	121,60	221,10			190,20	90,70	221,40	121,90	252,60	153,10
	4	4	132,60	241,20			179,20	70,60	210,40	101,80	241,50	133,00
SR825 TT70	4	0	195,0	354,0	355,0	196,0	493,0	333,0	561,0	402,0	630,0	471,0
	4	2	243,0	443,0	306,0	107,0	444,0	245,0	513,0	314,0	581,0	382,0
	4	3	268,0	487,0			420,0	201,0	488,0	269,0	557,0	338,0
	4	4	292,0	531,0			395,0	156,	464,0	225,0	533,0	294,0



+ Actuators

Specialist in Ball Valves

Solenoid Valve Mounting: Namur Type

Please ensure you read the IOM manual that is supplied with the solenoid valve in order to ensure correct function. This section is a guide to the function of a solenoid valve in conjunction with a pneumatic quarter turn actuator. The solenoid valves mentioned here are “**namur mounted**” with a modular “**5/2 way / 3/2 way**” (meaning either mode is possible with the same valve).

Certain facts need to be taken into consideration when mounting a namur solenoid valve to a quarter turn pneumatic actuator:

- Port “2” and “4” are always on the namur interface of the solenoid valve
- Port “2” and “4” are always connected to the namur interface of the quarter turn pneumatic actuator
- Port “1” is where instrument air is always connected to the solenoid valve
- Port “1” is always referred to as the air inlet or pressure port on a solenoid valve

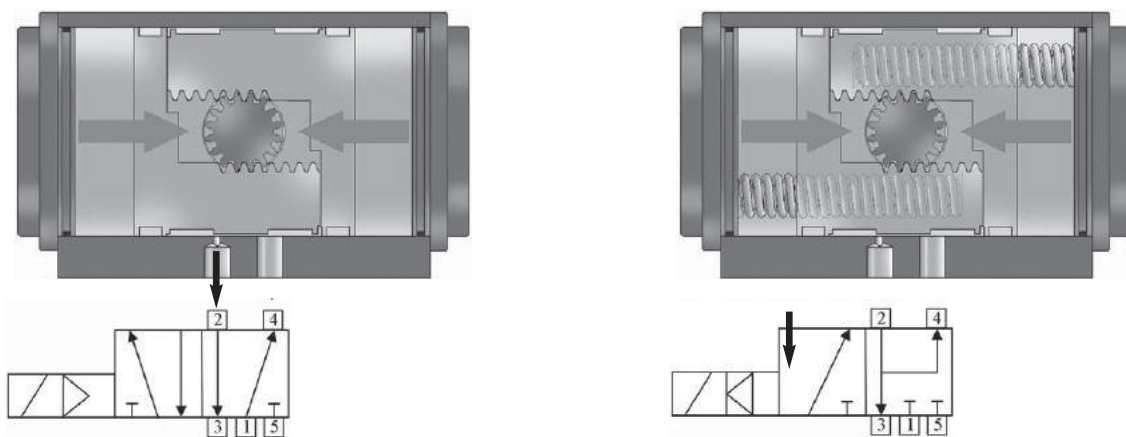

The above diagrams show a double acting actuator with 5/2 way solenoid valve (10.1) and a spring return actuator with a 5/2 way valve set up to function as a 3/2 way valve (10.2). Both valves are shown in the de-energised state (coil inactive, no electrical current). In both cases the solenoid valves port “2” is connected to the actuators port “A” through which air will vent out of port “3”. When connecting a namur solenoid valve, the pneumatic diagram will determine how to connect the ports. Only solenoid valve ports “2” and “4” can be connected to the actuator. Whichever of the two ports shows a vertical arrow pointing away from it, is the port that needs to be connected to the actuators central chamber, in this case port “A”.

+ Actuators

Operation with Solenoid Valves: Double Acting

Please ensure you read the IOM manual that is supplied with the solenoid valve in order to ensure correct function. This section is a guide to the function of a solenoid valve in conjunction with a pneumatic quarter turn actuator. The solenoid valves mentioned here are “**namur mounted**” with a modular “**5/2 way / 3/2 way**” (meaning either mode is possible with the same valve).

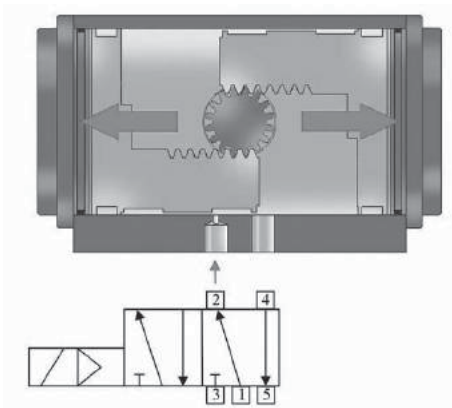

Solenoid Coil Energised:

- This allows air to flow from solenoid inlet port “1” to solenoid port “2” which is connected to actuator port “A”
- As the air enters the center chamber of the actuator, the pistons start to move towards the open position (as indicated by the large red arrows).
- Atmospheric air from the outer chambers will vent out of actuator port “B”, which is connected to solenoid port “4” and the exhausts via solenoid port “5”.
- Solenoid port “3” is not used.

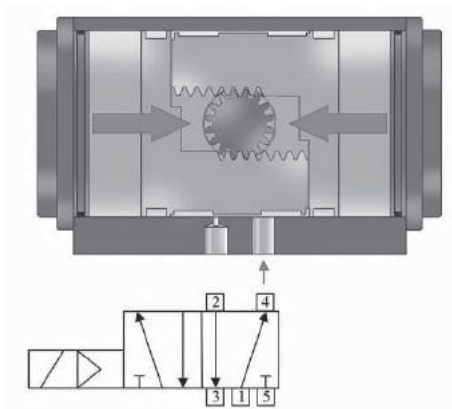

Solenoid Coil De-Energised:

- This allows air to flow from solenoid inlet port “1” to solenoid port “4” which is connected to actuator port “B”
- As the air enters the outer chambers of the actuator, the pistons start to move towards the closed position (as indicated by the large red arrows).
- Atmospheric air from the inner chamber will vent out of actuator port “A”, which is connected to solenoid port “2” and the exhausts via solenoid port “3”.
- Solenoid port “5” is not used.

+ Actuators

Specialist in Ball Valves

Operation with Solenoid Valves: Spring Return

Please ensure you read the IOM manual that is supplied with the solenoid valve in order to ensure correct function. This section is a guide to the function of a solenoid valve in conjunction with a pneumatic quarter turn actuator. The solenoid valves mentioned here are “**namur mounted**” with a modular “**5/2 way / 3/2 way**” (meaning either mode is possible with the same valve).

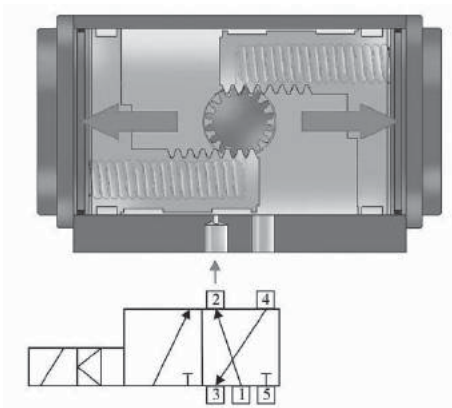

Solenoid Coil Energised:

- This allows air to flow from solenoid inlet port “1” to solenoid port “2” which is connected to actuator port ‘A’
- As the air enters the center chamber of the actuator, the pistons start to move towards the open position and compressing the springs in the outer chambers (as indicated by the large red arrows).
- Atmospheric air from the outer chambers will vent out of actuator port “B”, which is connected to solenoid port “4” and then exhausts via solenoid port “3”.
- Solenoid port “5” is not used.

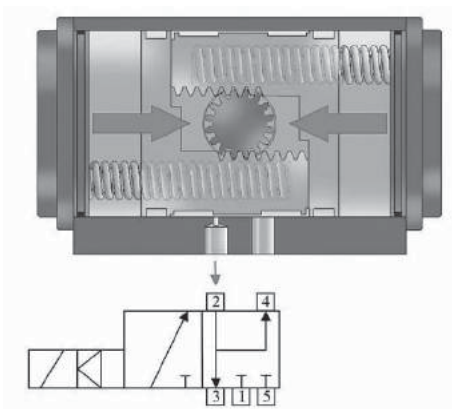

Solenoid Coil De-Energised:

- This closes solenoid port “1” and stops inlet air from flowing.
- The springs in the outer chambers will move the pistons back to the closed position (as indicated by the large red arrows).
- Residual air from the inner chamber will vent out of actuator port “A”, which is connected to solenoid port “2” and the exhausts via solenoid port “3”.
- Solenoid port “5” is not used.
- Solenoid port “2” and port “4” are also connected in a loop so no dirty air may enter the actuator (this is available only on some solenoid valves).

+ Actuators

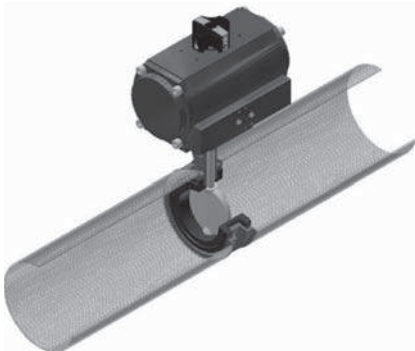

13.1 in-line, closed position

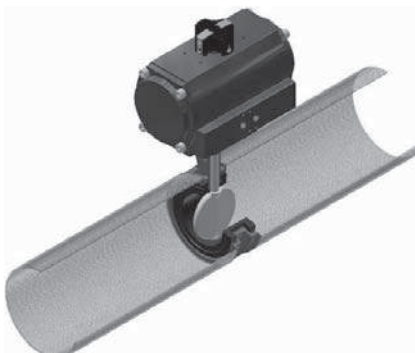

13.2 in-line, open position

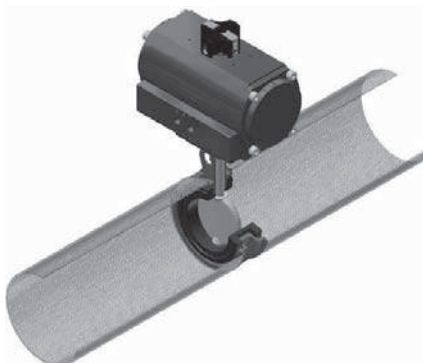

13.3 crossmount, closed position

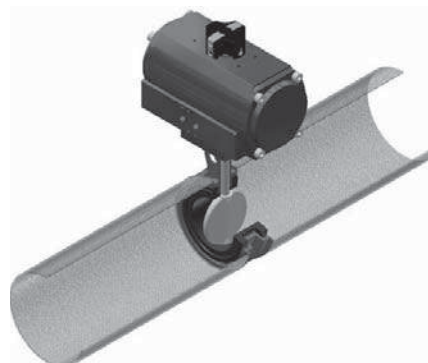

13.4 crossmount, open position

Mounting Variations

Below are the two common variations to mounting a 90 degree or 180 degree actuator to a valve.

- 13.1 mounted **in-line** or **parallel** to the pipe, the actuator and valve are in the standard closed position
- 13.2 mounted **in-line** or **parallel** to the pipe, the actuator and valve are in the standard open position
- 13.3 mounted **crossmount** or **offset** to the pipe, the actuator and valve are in the standard closed position
- 13.4 mounted **crossmount** or **offset** to the pipe, the actuator and valve are in the standard open position

Mounting actuators in these varying positions is due to space constraints in the global assembly or simply due to consistency with prior assemblies already in existence. Please note how the indicator puck always correctly shows the position of the valve disc and hence showing the flowpath of the medium running through the pipe.

+ Actuators

Specialist in Ball Valves

TORQUES (Nm) ACTUATOR GEMELS SEMPLY EFFECT

MODEL:	AIR SUPPLY														
	Springs Q.ty	Spring Torque		3 Bar		4 Bar		5 Bar		5.5 Bar		6 Bar		7 Bar	
		Start	End	Start	End	Start	End	Start	End	Start	End	Start	End	Start	End
SR 25	1	1.31	0.67	11.2	10.5	15.1	14.5	19.1	18.4	21.1	20.4	23.0	22.4	27.0	26.3
	2	2.62	1.34	10.5	9.2	14.5	13.2	18.4	17.1	20.4	19.1	22.4	21.1	26.3	25.0
	3	3.93	2.01	9.8	7.9	13.8	11.9	17.7	15.8	19.7	17.8	21.7	19.8	25.6	23.7
	4	5.24	2.68	9.2	6.6	13.1	10.6	17.1	14.5	19.0	16.5	21.0	18.5	25.0	22.4
	5	6.55	3.35	8.5	5.3	12.5	9.3	16.4	13.2	18.4	15.2	20.4	17.2	24.3	21.1
	6	7.86	4.02	7.8	4.0	11.8	7.9	15.7	11.9	17.7	13.9	19.7	15.8	23.6	19.8
	7	9.17	4.69			11.1	6.6	15.1	10.6	17.0	12.6	19.0	14.5	23.0	18.5
	8	10.48	5.36			10.4	5.3	14.4	9.3	16.4	11.2	18.3	13.2	22.3	17.2
	9	11.79	6.03					13.7	8.0	15.7	9.9	17.7	11.9	21.6	15.9
	10	13.10	6.70					13.1	6.7	15.0	8.6	17.0	10.6	21.0	14.6
	11	14.41	7.37							14.4	7.3	16.3	9.3	20.3	13.2
	12	15.72	8.04							13.7	6.0	15.7	8.0	19.6	11.9
SR 50	1	2.72	1.50	23.9	22.6	32.3	31.1	40.8	39.5	45.0	43.8	49.2	48.0	57.7	56.4
	2	5.44	3.00	22.4	19.9	30.8	28.4	39.3	36.8	43.5	41.0	47.7	45.3	56.2	53.7
	3	8.16	4.50	20.9	17.2	29.3	25.6	37.8	34.1	42.0	38.3	46.2	42.5	54.7	51.0
	4	10.88	6.00	19.4	14.5	27.8	22.9	36.3	31.4	40.5	35.6	44.7	39.8	53.2	48.3
	5	13.60	7.50	17.9	11.8	26.3	20.2	34.8	28.7	39.0	32.9	43.2	37.1	51.7	45.6
	6	16.32	9.00	16.4	9.0	24.8	17.5	33.3	25.9	37.5	30.2	41.7	34.4	50.2	42.8
	7	19.04	10.50			23.3	14.8	31.8	23.2	36.0	27.4	40.2	31.7	48.7	40.1
	8	21.76	12.00			21.8	12.0	30.3	20.5	34.5	24.7	38.7	28.9	47.2	37.4
	9	24.48	13.50					28.8	17.8	33.0	22.0	37.2	26.2	45.7	34.7
	10	27.20	15.00					27.3	15.1	31.5	19.3	35.7	23.5	44.2	32.0
	11	29.92	16.50							30.0	16.6	34.2	20.8	42.7	29.2
	12	32.64	18.00							28.5	13.8	32.7	18.1	41.2	26.5
SR 100	1	5.12	3.34	47.4	45.6	64.3	62.5	81.2	79.4	89.6	87.8	98.1	96.3	115.0	113.2
	2	10.24	6.68	44.0	40.5	60.9	57.4	77.8	74.3	86.3	82.7	94.7	91.2	111.6	108.1
	3	15.36	10.02	40.7	35.3	57.6	52.2	74.5	69.1	82.9	77.6	91.4	86.0	108.3	102.9
	4	20.48	13.36	37.3	30.2	54.2	47.1	71.1	64.0	79.6	72.5	88.0	80.9	104.9	97.8
	5	25.60	16.70	34.0	25.1	50.9	42.0	67.8	58.9	76.3	67.4	84.7	75.8	101.6	92.7
	6	30.72	20.04	30.7	20.0	47.6	36.9	64.5	53.8	72.9	62.2	81.4	70.7	98.3	87.6
	7	35.84	23.38			44.2	31.8	61.1	48.7	69.6	57.1	78.0	65.6	94.9	82.5
	8	40.96	26.72			40.9	26.6	57.8	43.5	66.2	52.0	74.7	60.4	91.6	77.3
	9	46.08	30.06					54.4	38.4	62.9	46.9	71.3	55.3	88.2	72.2
	10	51.20	33.40					51.1	33.3	59.6	41.8	68.0	50.2	84.9	67.1
	11	56.32	36.74							56.2	36.6	64.7	45.1	81.6	62.0
	12	61.44	40.08							52.9	31.5	61.3	40.0	78.2	56.9

Standard actuator.

NOTE:

For a continuous improvement, Gemels reserves the right to operate changes without prior notice.

For the values highlighted, or are missing, or with a minus sign (-), it is reported that with the number of standard springs, at 3 bar, the actuator is not able to overcome the force of the internal springs, therefore the actuator can not to perform one complete rotation. Therefore with air supply of 3 Bar, it will be necessary evaluate the reduction of the number of springs or buy a bigger model.

+ Actuators

TORQUES (Nm) ACTUATOR GEMELS SEMPLY EFFECT

MODEL:	Springs Q.ty		Spring Torque		AIR SUPPLY											
					3 Bar		4 Bar		5 Bar		5.5 Bar		6 Bar		7 Bar	
	Outer	Inner	Start	End	Start	End	Start	End	Start	End	Start	End	Start	End	Start	End
SR 200	1	0	21.7	11.9	89.0	79.3	122.7	112.9	156.3	146.6	173.2	163.4	190.0	180.2	223.7	213.9
	1	1	32.6	17.9	83.1	68.4	116.7	102.1	150.4	135.7	167.2	152.6	184.0	169.4	217.7	203.0
	2	0	43.4	23.9	77.1	57.6	110.8	91.2	144.4	124.9	161.2	141.7	178.1	158.5	211.7	192.2
	2	1	54.3	29.8	71.1	46.7	104.8	80.4	138.4	114.0	155.3	130.9	172.1	147.7	205.8	181.3
	2	2	65.1	35.8	65.2	35.9	98.8	69.5	132.5	103.2	149.3	120.0	166.1	136.8	199.8	170.5
	3	0	65.1	35.8	65.2	35.9	98.8	69.5	132.5	103.2	149.3	120.0	166.1	136.8	199.8	170.5
	3	1	76.0	41.8	59.2	25.0	92.9	58.7	126.5	92.3	143.3	109.2	160.2	126.0	193.8	159.6
	3	2	86.8	47.7	53.2	14.2	86.9	47.8	120.5	81.5	137.4	98.3	154.2	115.1	187.9	148.8
	3	3	97.7	53.7	47.3	3.3	80.9	37.0	114.6	70.6	131.4	87.5	148.2	104.3	181.9	137.9
	4	0	86.8	47.7	53.2	14.2	86.9	47.8	120.6	81.5	137.4	98.3	154.2	115.1	187.9	148.8
	4	1	97.7	53.7	47.3	3.3	80.9	37.0	114.6	70.6	131.4	87.5	148.2	104.3	181.9	137.9
	4	2	108.5	59.7	41.3	-7.5	75.0	26.1	108.6	59.8	125.4	76.6	142.3	93.4	175.9	127.1
	4	3	119.4	65.6	35.3	-18.4	69.0	15.3	102.6	48.9	119.5	65.8	136.3	82.6	170.0	116.2
	4	4	130.2	71.6	29.4	-29.2	63.0	4.4	96.7	38.1	113.5	54.9	130.3	71.7	164.0	105.4
SR 375	1	0	40.2	22.1	165.0	146.9	227.3	209.3	289.7	271.6	320.9	302.8	352.1	334.0	414.4	396.3
	1	1	60.3	33.2	153.9	126.8	216.3	189.2	278.7	251.5	309.8	282.7	341.0	313.9	403.4	376.2
	2	0	80.4	44.2	142.9	106.7	205.2	169.1	267.6	231.4	298.8	262.6	330.0	293.8	392.3	356.1
	2	1	100.5	55.3	131.8	86.6	194.2	149.0	256.5	211.3	287.7	242.5	318.9	273.7	381.3	336.0
	2	2	120.6	66.3	120.8	66.5	183.1	128.9	245.5	191.2	276.7	222.4	307.9	253.6	370.2	315.9
	3	0	120.6	66.3	120.8	66.5	183.1	128.9	245.5	191.2	276.7	222.4	307.9	253.6	370.2	315.9
	3	1	140.7	77.4	109.7	46.4	172.1	108.8	234.4	171.1	265.6	202.3	296.8	233.5	359.2	295.8
	3	2	160.8	88.4	98.7	26.3	161.0	88.7	223.4	151.0	254.6	182.2	285.8	213.4	348.1	275.7
	3	3	180.9	99.5	87.6	6.2	150.0	68.6	212.3	130.9	243.5	162.1	274.7	193.3	337.1	255.6
	4	0	160.8	88.4	98.7	26.3	161.0	88.7	223.4	151.0	254.6	182.2	285.7	213.4	348.1	275.7
	4	1	180.9	99.5	87.6	6.2	150.0	68.6	212.3	130.9	243.5	162.1	274.7	193.3	337.1	255.6
	4	2	201.0	110.5	76.6	-13.9	138.9	48.5	201.3	110.8	232.5	142.0	263.6	173.2	326.0	235.5
	4	3	221.1	121.6	65.5	-34.0	127.9	28.4	190.2	90.7	221.4	121.9	252.6	153.1	315.0	215.4
	4	4	241.2	132.6	54.5	-54.1	116.8	8.3	179.2	70.6	210.4	101.8	241.5	133.0	303.9	195.3

 = Standard actuator.

NOTE:

For a continuous improvement, Gemels reserves the right to operate changes without prior notice.
For the values highlighted, or are missing, or with a minus sign (-), it is reported that with the number of standard springs, at 3 bar, the actuator is not able to overcome the force of the internal springs, therefore the actuator can not to perform one complete rotation. Therefore with air supply of 3 Bar, it will be necessary evaluate the reduction of the number of springs or buy a bigger model.



+ Actuators

Specialist in Ball Valves

TORQUES (Nm) ACTUATOR GEMELS SEMPLY EFFECT

MODEL:	Springs Q.ty		Spring Torque		AIR SUPPLY											
					3 Bar		4 Bar		5 Bar		5.5 Bar		6 Bar		7 Bar	
	Outer	Inner	Start	End	Start	End	Start	End	Start	End	Start	End	Start	End	Start	End
SR 580	1	0	64.1	35.3	263.1	234.3	362.6	333.7	462.0	433.2	511.8	482.9	561.5	532.6	660.9	632.1
	1	1	96.2	52.9	245.5	202.2	344.9	301.7	444.4	401.1	494.1	450.9	543.8	500.6	643.3	600.0
	2	0	128.2	70.5	227.9	170.2	327.3	269.6	426.8	369.1	476.5	418.8	526.2	468.5	625.7	568.0
	2	1	160.3	88.1	210.2	138.1	309.7	237.6	409.1	337.0	458.9	386.8	508.6	436.5	608.1	535.9
	2	2	192.3	105.8	192.6	106.1	292.1	205.5	391.5	305.0	441.2	354.7	491.0	404.4	590.4	503.9
	3	0	192.3	105.8	192.6	106.1	292.1	205.5	391.5	305.0	441.3	354.7	491.0	404.4	590.4	503.9
	3	1	224.4	123.4	175.0	74.0	274.4	173.5	373.9	272.9	423.6	322.7	473.3	372.4	572.8	471.8
	3	2	256.4	141.0	157.4	42.0	256.8	141.4	356.3	240.9	406.0	290.6	455.7	340.3	555.2	439.8
	3	3	288.5	158.6	139.7	9.9	239.2	109.4	338.6	208.8	388.4	258.6	438.1	308.3	537.5	407.7
	4	0	256.4	141.0	157.4	42.0	256.8	141.4	356.3	240.9	406.0	290.6	455.7	340.3	555.2	439.8
	4	1	288.5	158.6	139.7	9.9	239.2	109.4	338.6	208.8	388.4	258.6	438.1	308.3	537.6	407.7
	4	2	320.5	176.3	122.1	-22.1	221.6	77.3	321.0	176.8	370.7	226.5	420.5	276.2	519.9	375.7
	4	3	352.6	193.9	104.5	-54.2	203.9	45.3	303.4	144.7	353.1	194.5	402.8	244.2	502.3	343.6
	4	4	384.6	211.5	86.8	-86.2	186.3	13.2	285.8	112.7	335.5	162.4	385.2	212.1	484.7	311.6
SR 825	1	0	89	49	364	324	501	461	639	599	707	668	776	736	914	874
	1	1	133	73	339	280	477	417	614	555	683	623	752	692	889	829
	2	0	177	97	315	235	452	373	590	510	659	579	727	648	865	785
	2	1	221	122	291	191	428	329	566	466	634	535	703	603	841	741
	2	2	266	146	266	147	404	284	541	422	610	491	679	559	816	697
	3	0	266	146	266	147	404	284	541	422	610	491	679	559	816	697
	3	1	310	170	242	103	379	240	517	378	586	446	654	515	792	652
	3	2	354	195	218	58	355	196	493	333	561	402	630	471	767	608
	3	3	398	219	193	14	331	152	468	289	537	358	606	426	743	564
	4	0	354	195	218	58	355	196	493	333	561	402	630	471	768	608
	4	1	398	219	193	14	331	152	468	289	537	358	606	426	743	564
	4	2	443	243	169	-30	306	107	444	245	513	314	581	382	719	520
	4	3	487	268	145	-74	282	63	420	201	488	269	557	338	694	475
	4	4	531	292	120	-119	258	19	395	156	464	225	533	294	670	431

 = Standard actuator.

NOTE:

For a continuous improvement, Gemels reserves the right to operate changes without prior notice.

For the values highlighted, or are missing, or with a minus sign (-), it is reported that with the number of standard springs, at 3 bar, the actuator is not able to overcome the force of the internal springs, therefore the actuator can not to perform one complete rotation. Therefore with air supply of 3 Bar, it will be necessary evaluate the reduction of the number of springs or buy a bigger model.

+ Actuators

www.gemels.it

TORQUES (Nm) ACTUATOR GEMELS DOUBLE EFFECT

MODEL	AIR SUPPLY					
	3 Bar	4 Bar	5 Bar	5.5 Bar	6 Bar	7 Bar
DA 25	11.9	15.8	19.8	21.7	23.7	27.7
DA 50	25.4	33.8	42.3	46.5	50.7	59.2
DA 100	50.7	67.6	84.5	93.0	101.4	118.3
DA 200	101.0	134.6	168.3	185.1	201.9	235.6
DA 375	187	249	312	343	374	437
DA 580	298	398	497	547	597	696
DA 825	412	550	687	756	825	962

WARNING: NEVER DISASSEMBLE A PRESSURISED UNIT!

**Always isolate the actuator pneumatically
or hydraulically and electrically.**

**Always remove all accessories
and mounting hardware prior to maintenance.**

Other Information

Actuator Lubricant: BERULUB FR16
Spring Lubrications: VALVOLINE L-EP2

Always insure you wear the correct safety equipment as stipulated
by your local organisation and applicable laws.

+ Seals kits

Specialist in Ball Valves

GB

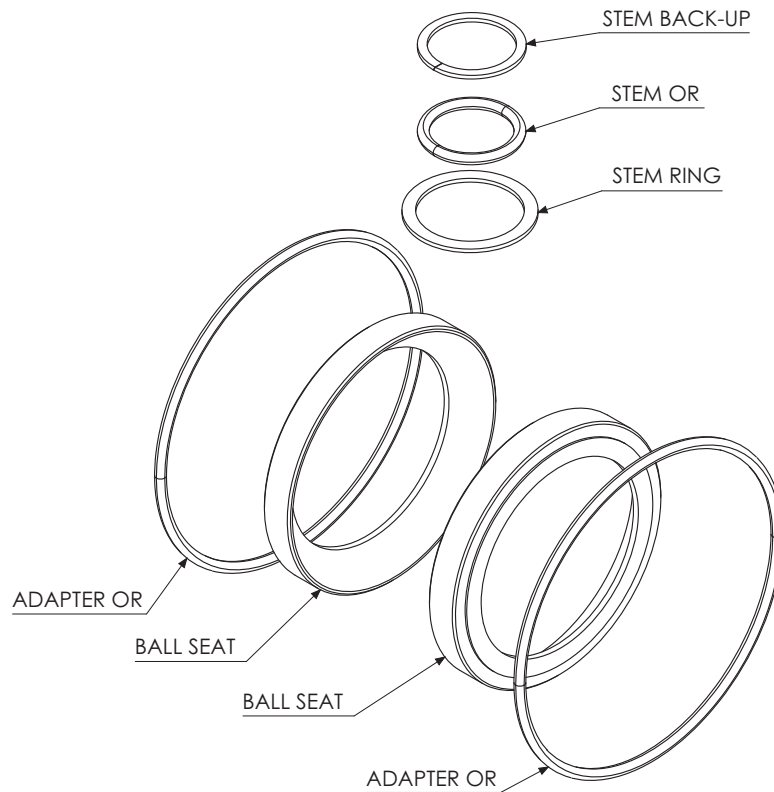

SEALS KITS-AB

TYPE	BALL SEAT	O-RING	STEM RING	WEIGHT Kg	KIT CODE
GB DN32	POM	NBR	POM	0,02	KBST6AHH
GB DN40	POM	NBR	POM	0,02	KBST7AHH
GB DN50	POM	NBR	POM	0,03	KBST8AHH

SEALS KITS-AE

TYPE	BALL SEAT	O-RING	STEM RING	WEIGHT Kg	KIT CODE
GB DN32	POM	FKM	POM	0,02	KBST6BHH
GB DN40	POM	FKM	POM	0,02	KBST7BHH
GB DN50	POM	FKM	POM	0,03	KBST8BHH

SEALS KITS-AF

TYPE	BALL SEAT	O-RING	STEM RING	WEIGHT Kg	KIT CODE
GB DN32	POM	EPDM	POM	0,02	KBST6CHH
GB DN40	POM	EPDM	POM	0,02	KBST7CHH
GB DN50	POM	EPDM	POM	0,03	KBST8CHH

SEALS KITS-CB

TYPE	BALL SEAT	O-RING	STEM RING	WEIGHT Kg	KIT CODE
GB DN32	PTFE	NBR	POM	0,02	KBST6FHH
GB DN40	PTFE	NBR	POM	0,04	KBST7FHH
GB DN50	PTFE	NBR	POM	0,05	KBST8FHH

SEALS KITS-CE

TYPE	BALL SEAT	O-RING	STEM RING	WEIGHT Kg	KIT CODE
GB DN32	PTFE	FKM	POM	0,02	KBST6GHH
GB DN40	PTFE	FKM	POM	0,04	KBST7GHH
GB DN50	PTFE	FKM	POM	0,05	KBST8GHH

+ Seals kits

Specialist in Ball Valves

GB

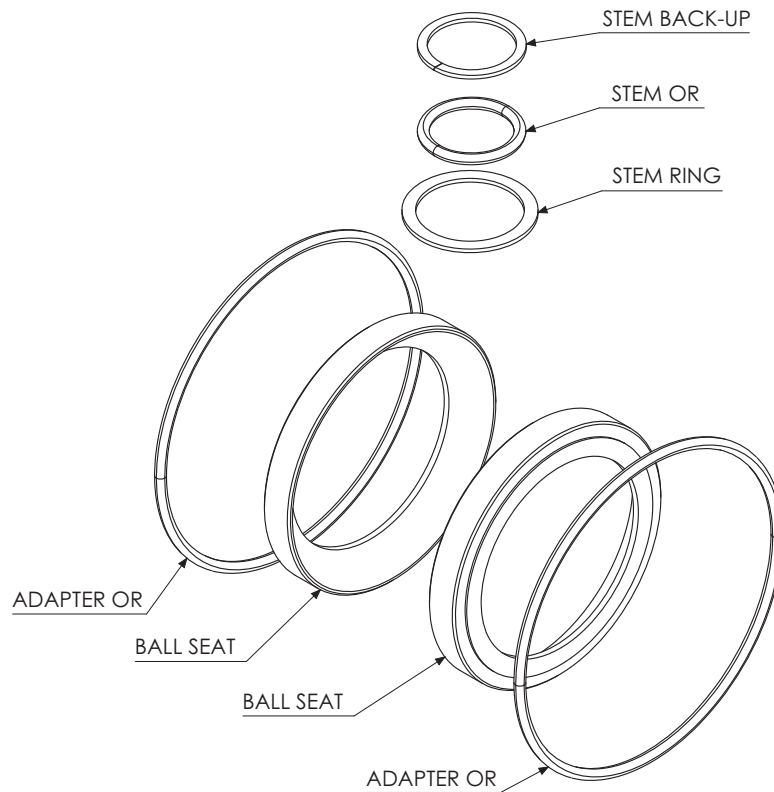

SEALS KITS-CF

TYPE	BALL SEAT	O-RING	STEM RING	STEM BACK-UP	Kg	KIT CODE
GB DN32	PTFE	EPDM	POM	PTFE	0,02	KBST6MHH
GB DN40	PTFE	EPDM	POM	PTFE	0,04	KBST7MHH
GB DN50	PTFE	EPDM	POM	PTFE	0,05	KBST8MHH

SEALS KITS-DB

TYPE	BALL SEAT	O-RING	STEM RING	STEM BACK-UP	Kg	KIT CODE
GB DN32	PEEK	NBR	PEEK	PTFE	0,02	KBST6PHH
GB DN40	PEEK	NBR	PEEK	PTFE	0,02	KBST7PHH
GB DN50	PEEK	NBR	PEEK	PTFE	0,03	KBST8PHH

SEALS KITS-DE

TYPE	BALL SEAT	O-RING	STEM RING	STEM BACK-UP	Kg	KIT CODE
GB DN32	PEEK	FKM	PEEK	PTFE	0,02	KBST6NHH
GB DN40	PEEK	FKM	PEEK	PTFE	0,02	KBST7NHH
GB DN50	PEEK	FKM	PEEK	PTFE	0,03	KBST8NHH

SEALS KITS-DF

TYPE	BALL SEAT	O-RING	STEM RING	STEM BACK-UP	Kg	KIT CODE
GB DN32	PEEK	EPDM	PEEK	PTFE	0,02	KBST6OHH
GB DN40	PEEK	EPDM	PEEK	PTFE	0,02	KBST7OHH
GB DN50	PEEK	EPDM	PEEK	PTFE	0,03	KBST8OHH

SEALS KITS-GB

TYPE	BALL SEAT	O-RING	STEM RING	STEM BACK-UP	Kg	KIT CODE
GB DN32	PA612	NBR	PA612	PTFE	0,02	KBST6THH
GB DN40	PA612	NBR	PA612	PTFE	0,02	KBST7THH
GB DN50	PA612	NBR	PA612	PTFE	0,03	KBST8THH

+ Seals kits

www.gemels.it

GB

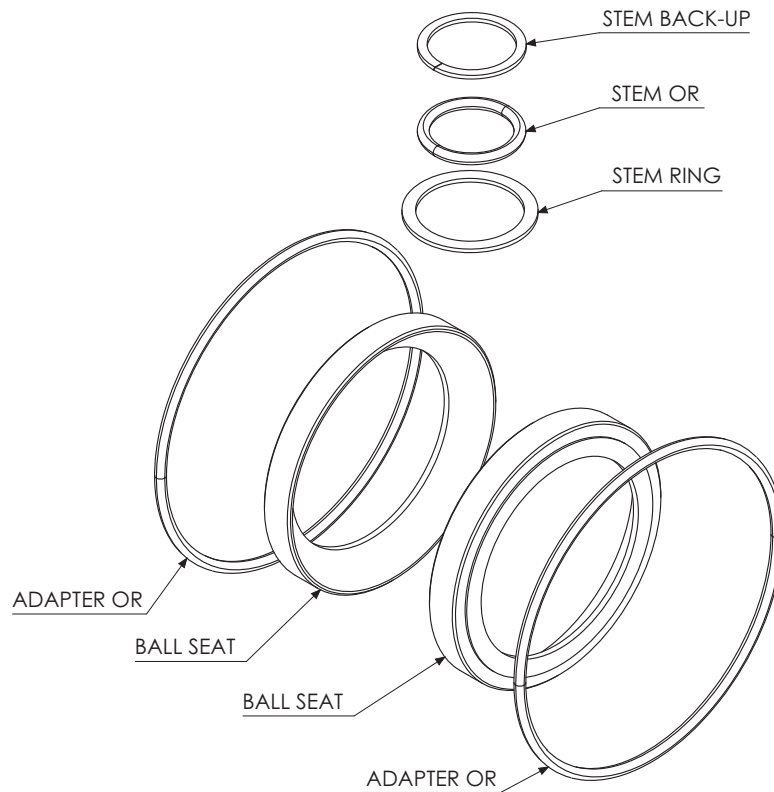

SEALS KITS-GE

TYPE	BALL SEAT	O-RING	STEM RING	STEM BACK-UP	Kg	KIT CODE
GB DN32	PA612	FKM	PA612	PTFE	0,02	KBST6DHH
GB DN40	PA612	FKM	PA612	PTFE	0,02	KBST7DHH
GB DN50	PA612	FKM	PA612	PTFE	0,03	KBST8DHH

SEALS KITS-GF

TYPE	BALL SEAT	O-RING	STEM RING	STEM BACK-UP	Kg	KIT CODE
GB DN32	PA612	EPDM	PA612	PTFE	0,02	KBST6EHH
GB DN40	PA612	EPDM	PA612	PTFE	0,02	KBST7EHH
GB DN50	PA612	EPDM	PA612	PTFE	0,03	KBST8EHH

SEALS KITS-KB

TYPE	BALL SEAT	O-RING	STEM RING	STEM BACK-UP	Kg	KIT CODE
GB DN32	GEMPTFE	NBR	POM	PTFE	0,02	KEST1LHH
GB DN40	GEMPTFE	NBR	POM	PTFE	0,02	KEST2LHH
GB DN50	GEMPTFE	NBR	POM	PTFE	0,03	KEST3LHH

SEALS KITS-KE

TYPE	BALL SEAT	O-RING	STEM RING	STEM BACK-UP	Kg	KIT CODE
GB DN32	GEMPTFE	FKM	POM	PTFE	0,02	KBST6IHH
GB DN40	GEMPTFE	FKM	POM	PTFE	0,02	KBST7IHH
GB DN50	GEMPTFE	FKM	POM	PTFE	0,03	KBST8IHH

SEALS KITS-KF

TYPE	BALL SEAT	O-RING	STEM RING	STEM BACK-UP	Kg	KIT CODE
GB DN32	GEMPTFE	EPDM	POM	PTFE	0,02	KBST6HHH
GB DN40	GEMPTFE	EPDM	POM	PTFE	0,02	KBST7HHH
GB DN50	GEMPTFE	EPDM	POM	PTFE	0,03	KBST8HHH

Seals

+ Seals kits

Specialist in Ball Valves

GE

**STEM BACK-UP
ONLY FOR DN 20/25**

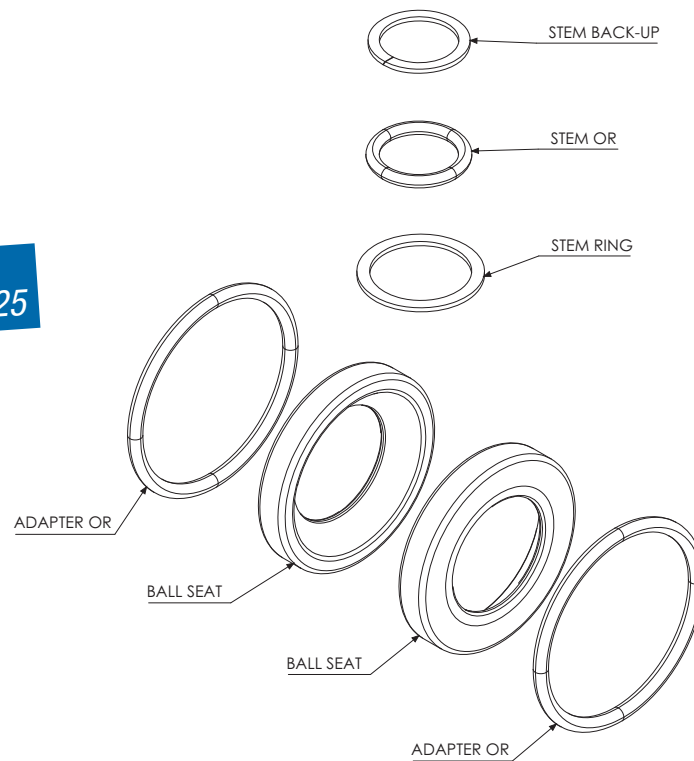

SEALS KITS-AB

TYPE	BALL SEAT	O-RING	STEM RING	STEM BACK-UP	Kg	KIT CODE
GE DN6	POM	NBR	POM	PTFE	0	KEST1AHH
GE DN10	POM	NBR	POM	PTFE	0,01	KEST2AHH
GE DN13	POM	NBR	POM	PTFE	0,01	KEST3AHH
GE DN20	POM	NBR	POM	PTFE	0,01	KEST4AHH
GE DN25	POM	NBR	POM	PTFE	0,02	KEST5AHH

SEALS KITS-AE

TYPE	BALL SEAT	O-RING	STEM RING	STEM BACK-UP	Kg	KIT CODE
GE DN6	POM	FKM	POM	PTFE	0	KEST1BHH
GE DN10	POM	FKM	POM	PTFE	0,01	KEST2BHH
GE DN13	POM	FKM	POM	PTFE	0,01	KEST3BHH
GE DN20	POM	FKM	POM	PTFE	0,01	KEST4BHH
GE DN25	POM	FKM	POM	PTFE	0,02	KEST5BHH

SEALS KITS-AF

TYPE	BALL SEAT	O-RING	STEM RING	STEM BACK-UP	Kg	KIT CODE
GE DN6	POM	EPDM	POM	PTFE	0	KEST1CHH
GE DN10	POM	EPDM	POM	PTFE	0,01	KEST2CHH
GE DN13	POM	EPDM	POM	PTFE	0,01	KEST3CHH
GE DN20	POM	EPDM	POM	PTFE	0,01	KEST4CHH
GE DN25	POM	EPDM	POM	PTFE	0,02	KEST5CHH

SEALS KITS-CB

TYPE	BALL SEAT	O-RING	STEM RING	STEM BACK-UP	Kg	KIT CODE
GE DN6	PTFE	NBR	POM	PTFE	0,01	KEST1FHH
GE DN10	PTFE	NBR	POM	PTFE	0,01	KEST2FHH
GE DN13	PTFE	NBR	POM	PTFE	0,01	KEST3FHH
GE DN20	PTFE	NBR	POM	PTFE	0,02	KEST4FHH
GE DN25	PTFE	NBR	POM	PTFE	0,03	KEST5FHH

SEALS KITS-CE

TYPE	BALL SEAT	O-RING	STEM RING	STEM BACK-UP	Kg	KIT CODE
GE DN6	PTFE	FKM	POM	PTFE	0,01	KEST1GHH
GE DN10	PTFE	FKM	POM	PTFE	0,01	KEST2GHH
GE DN13	PTFE	FKM	POM	PTFE	0,01	KEST3GHH
GE DN20	PTFE	FKM	POM	PTFE	0,02	KEST4GHH
GE DN25	PTFE	FKM	POM	PTFE	0,03	KEST5GHH

"The company reserves the right to operate dimensional changes without prior notice".

+ Seals kits

www.gemels.it

GE

**STEM BACK-UP
ONLY FOR DN 20/25**

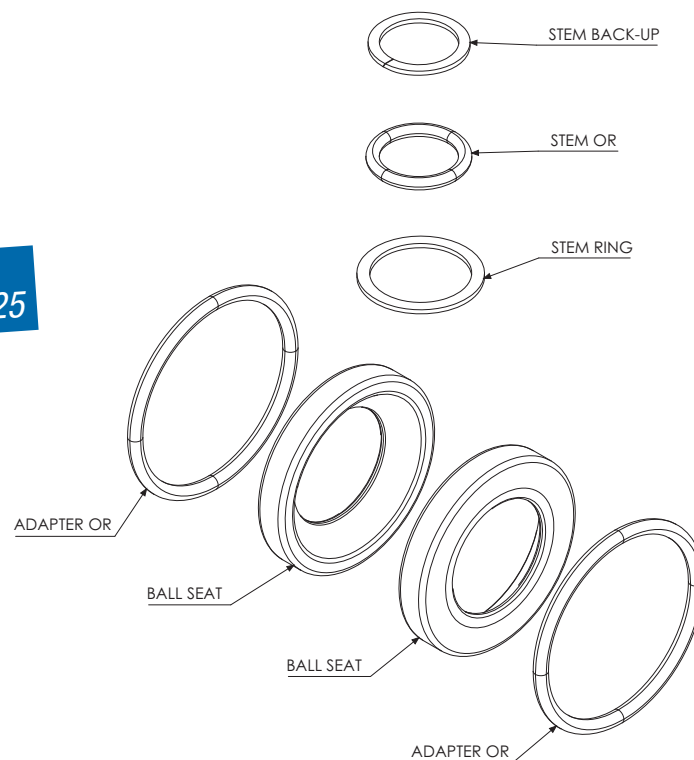

SEALS KITS-CF

TYPE	BALL SEAT	O-RING	STEM RING	STEM BACK-UP	Kg	KIT CODE
GE DN6	PTFE	EPDM	POM	PTFE	0,01	KEST1MHH
GE DN10	PTFE	EPDM	POM	PTFE	0,01	KEST2MHH
GE DN13	PTFE	EPDM	POM	PTFE	0,01	KEST3MHH
GE DN20	PTFE	EPDM	POM	PTFE	0,02	KEST4MHH
GE DN25	PTFE	EPDM	POM	PTFE	0,03	KEST5MHH

SEALS KITS-DB

TYPE	BALL SEAT	O-RING	STEM RING	STEM BACK-UP	Kg	KIT CODE
GE DN6	PEEK	NBR	PEEK	PTFE	0	KEST1PHH
GE DN10	PEEK	NBR	PEEK	PTFE	0,01	KEST2PHH
GE DN13	PEEK	NBR	PEEK	PTFE	0,01	KEST3PHH
GE DN20	PEEK	NBR	PEEK	PTFE	0,01	KEST4PHH
GE DN25	PEEK	NBR	PEEK	PTFE	0,02	KEST5PHH

SEALS KITS-DE

TYPE	BALL SEAT	O-RING	STEM RING	STEM BACK-UP	Kg	KIT CODE
GE DN6	PEEK	FKM	PEEK	PTFE	0	KEST1NHH
GE DN10	PEEK	FKM	PEEK	PTFE	0,01	KEST2NHH
GE DN13	PEEK	FKM	PEEK	PTFE	0,01	KEST3NHH
GE DN20	PEEK	FKM	PEEK	PTFE	0,01	KEST4NHH
GE DN25	PEEK	FKM	PEEK	PTFE	0,02	KEST5NHH

SEALS KITS-DF

TYPE	BALL SEAT	O-RING	STEM RING	STEM BACK-UP	Kg	KIT CODE
GE DN6	PEEK	EPDM	PEEK	PTFE	0	KEST10HH
GE DN10	PEEK	EPDM	PEEK	PTFE	0,01	KEST20HH
GE DN13	PEEK	EPDM	PEEK	PTFE	0,01	KEST30HH
GE DN20	PEEK	EPDM	PEEK	PTFE	0,01	KEST40HH
GE DN25	PEEK	EPDM	PEEK	PTFE	0,02	KEST50HH

SEALS KITS-GB

TYPE	BALL SEAT	O-RING	STEM RING	STEM BACK-UP	Kg	KIT CODE
GE DN6	PA612	NBR	PA612	PTFE	0	KEST1THH
GE DN10	PA612	NBR	PA612	PTFE	0,01	KEST2THH
GE DN13	PA612	NBR	PA612	PTFE	0,01	KEST3THH
GE DN20	PA612	NBR	PA612	PTFE	0,01	KEST4THH
GE DN25	PA612	NBR	PA612	PTFE	0,02	KEST5THH

Seals

+ Seals kits

Specialist in Ball Valves

GE

**STEM BACK-UP
ONLY FOR DN 20/25**

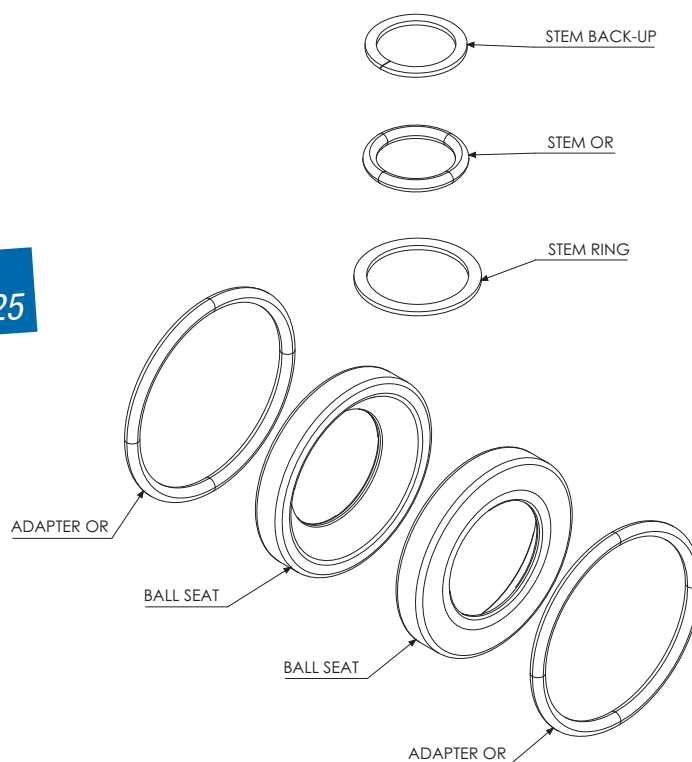

SEALS KITS-GE

TYPE	BALL SEAT	O-RING	STEM RING	STEM BACK-UP	Kg	KIT CODE
GE DN6	PA612	FKM	PA612	PTFE	0	KEST1DHH
GE DN10	PA612	FKM	PA612	PTFE	0,01	KEST2DHH
GE DN13	PA612	FKM	PA612	PTFE	0,01	KEST3DHH
GE DN20	PA612	FKM	PA612	PTFE	0,01	KEST4DHH
GE DN25	PA612	FKM	PA612	PTFE	0,02	KEST5DHH

SEALS KITS-GF

TYPE	BALL SEAT	O-RING	STEM RING	STEM BACK-UP	Kg	KIT CODE
GE DN6	PA612	EPDM	PA612	PTFE	0	KEST1EHH
GE DN10	PA612	EPDM	PA612	PTFE	0,01	KEST2EHH
GE DN13	PA612	EPDM	PA612	PTFE	0,01	KEST3EHH
GE DN20	PA612	EPDM	PA612	PTFE	0,01	KEST4EHH
GE DN25	PA612	EPDM	PA612	PTFE	0,02	KEST5EHH

SEALS KITS-KB

TYPE	BALL SEAT	O-RING	STEM RING	STEM BACK-UP	Kg	KIT CODE
GE DN6	GEMPTFE	NBR	POM	PTFE	0	KEST1LHH
GE DN10	GEMPTFE	NBR	POM	PTFE	0,01	KEST2LHH
GE DN13	GEMPTFE	NBR	POM	PTFE	0,01	KEST3LHH
GE DN20	GEMPTFE	NBR	POM	PTFE	0,01	KEST4LHH
GE DN25	GEMPTFE	NBR	POM	PTFE	0,02	KEST5LHH

SEALS KITS-KE

TYPE	BALL SEAT	O-RING	STEM RING	STEM BACK-UP	Kg	KIT CODE
GE DN6	GEMPTFE	FKM	POM	PTFE	0	KEST1IHH
GE DN10	GEMPTFE	FKM	POM	PTFE	0,01	KEST2IHH
GE DN13	GEMPTFE	FKM	POM	PTFE	0,01	KEST3IHH
GE DN20	GEMPTFE	FKM	POM	PTFE	0,01	KEST4IHH
GE DN25	GEMPTFE	FKM	POM	PTFE	0,02	KEST5IHH

SEALS KITS-KF

TYPE	BALL SEAT	O-RING	STEM RING	STEM BACK-UP	Kg	KIT CODE
GE DN6	GEMPTFE	EPDM	POM	PTFE	0	KEST1HHH
GE DN10	GEMPTFE	EPDM	POM	PTFE	0,01	KEST2HHH
GE DN13	GEMPTFE	EPDM	POM	PTFE	0,01	KEST3HHH
GE DN20	GEMPTFE	EPDM	POM	PTFE	0,01	KEST4HHH
GE DN25	GEMPTFE	EPDM	POM	PTFE	0,02	KEST5HHH

"The company reserves the right to operate dimensional changes without prior notice".

+ Seals kits

www.gemels.it

GE1-GE5

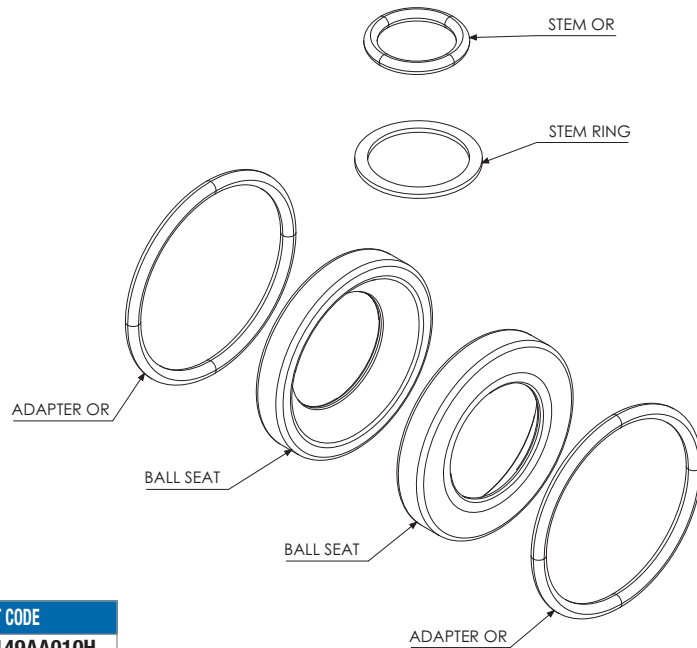

SEALS KITS-AB

TYPE	BALL SEAT	O-RING	STEM RING	Kg	KIT CODE
GE1-GE5 DN6	POM	NBR	POM	0	K08A00149AA010H
GE1-GE5 DN10	POM	NBR	POM	0,01	K08A00150AA010H
GE1-GE5 DN13	POM	NBR	POM	0,01	K08A00151AA010H

GE3K

**STEM BACK-UP
ONLY FOR DN 20/25**

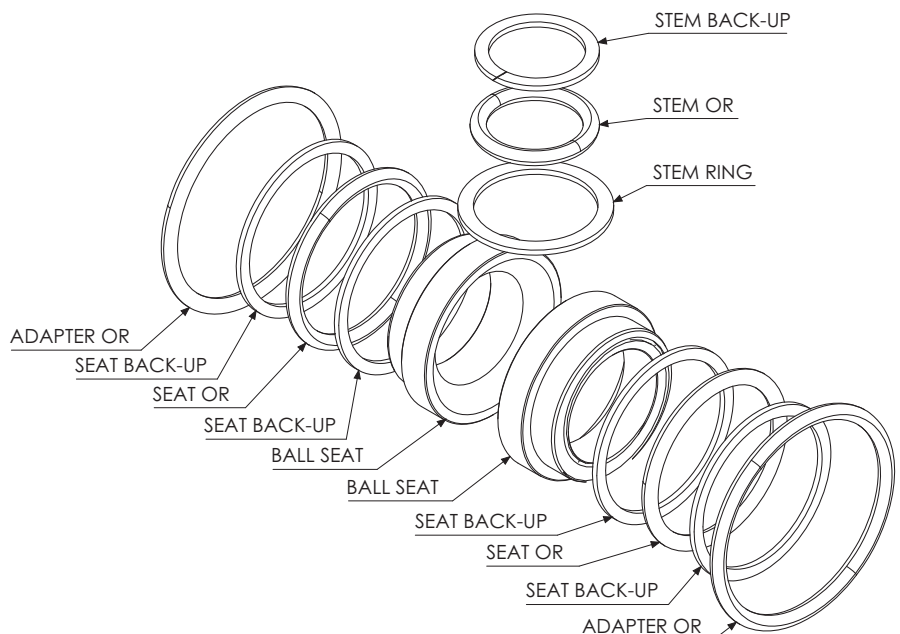

SEALS KITS-AB

TYPE	BALL SEAT	O-RING	SEAT BACK-UP	STEM RING	STEM BACK-UP	Kg	KIT CODE
GE3K DN6	POM	NBR	PTFE	POM	PTFE	0,01	KKST1AHH
GE3K DN10	POM	NBR	PTFE	POM	PTFE	0,01	KKST2AHH
GE3K DN13	POM	NBR	PTFE	POM	PTFE	0,01	KKST3AHH
GE3K DN20	POM	NBR	PTFE	POM	PTFE	0,02	KKST4AHH
GE3K DN25	POM	NBR	PTFE	POM	PTFE	0,03	KKST5AHH



+ Seals kits

Specialist in Ball Valves

GM GN

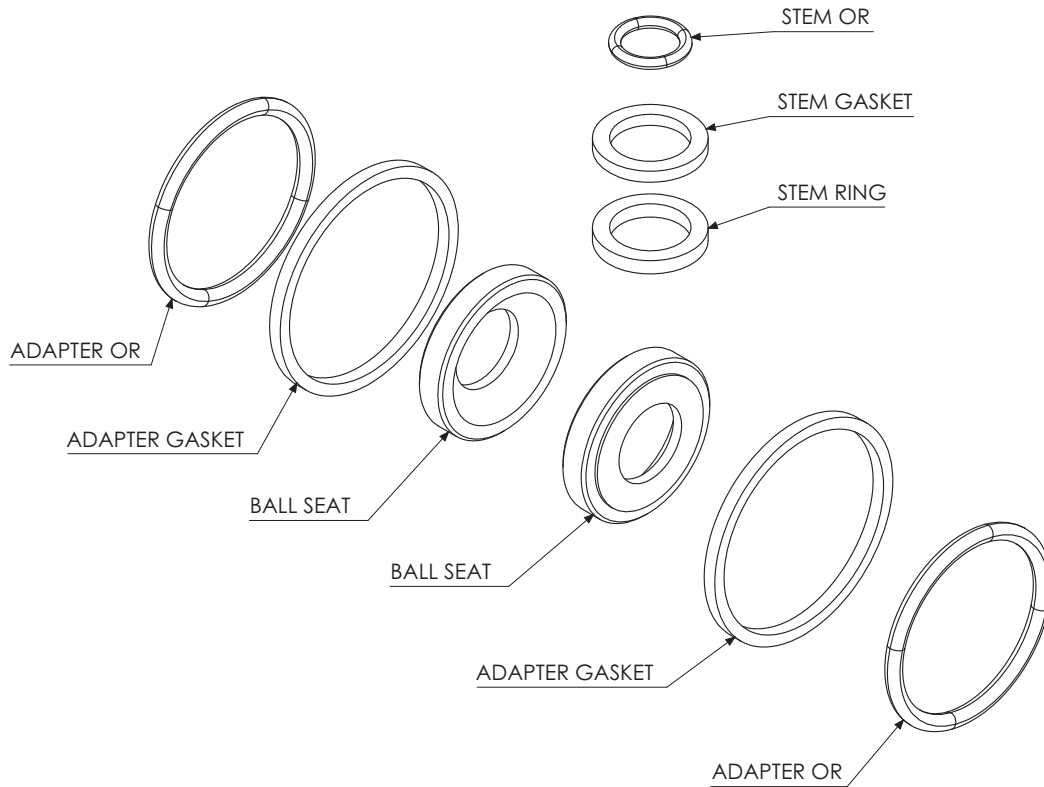

SEALS KITS-AB

TYPE	BALL SEAT	O-RING	ADAPTER GASKET	STEM RING	STEM GASKET	Kg	KIT CODE
GM GN DN6	POM	NBR	GRAPHITE	PTFE	GRAPHITE	0,01	KMST1AHH
GM GN DN10	POM	NBR	GRAPHITE	PTFE	GRAPHITE	0,01	KMST2AHH
GM GN DN13	POM	NBR	GRAPHITE	PTFE	GRAPHITE	0,01	KMST3AHH
GM GN DN20	POM	NBR	GRAPHITE	PTFE	GRAPHITE	0,02	KMST4AHH
GM GN DN25	POM	NBR	GRAPHITE	PTFE	GRAPHITE	0,02	KMST5AHH
GM GN DN32	POM	NBR	GRAPHITE	PTFE	GRAPHITE	0,02	KMST6AHH
GM GN DN40	POM	NBR	GRAPHITE	PTFE	GRAPHITE	0,03	KMST7AHH
GM GN DN50	POM	NBR	GRAPHITE	PTFE	GRAPHITE	0,03	KMST8AHH
GM GN DN65	POM	NBR	GRAPHITE	PTFE	GRAPHITE	0,06	KMST9AHH
GM GN DN80	POM	NBR	GRAPHITE	PTFE	GRAPHITE	0,08	KMSTAAHH
GM GN DN100	POM	NBR	GRAPHITE	PTFE	GRAPHITE	0,11	KMSTBAHH

SEALS KITS-AE

TYPE	BALL SEAT	O-RING	ADAPTER GASKET	STEM RING	STEM GASKET	Kg	KIT CODE
GM GN DN6	POM	FKM	GRAPHITE	PTFE	GRAPHITE	0,01	KMST1BHH
GM GN DN10	POM	FKM	GRAPHITE	PTFE	GRAPHITE	0,01	KMST2BHH
GM GN DN13	POM	FKM	GRAPHITE	PTFE	GRAPHITE	0,01	KMST3BHH
GM GN DN20	POM	FKM	GRAPHITE	PTFE	GRAPHITE	0,02	KMST4BHH
GM GN DN25	POM	FKM	GRAPHITE	PTFE	GRAPHITE	0,02	HKMST5BHH
GM GN DN32	POM	FKM	GRAPHITE	PTFE	GRAPHITE	0,02	KMST6BHH
GM GN DN40	POM	FKM	GRAPHITE	PTFE	GRAPHITE	0,03	KMST7BHH
GM GN DN50	POM	FKM	GRAPHITE	PTFE	GRAPHITE	0,03	KMST8BHH
GM GN DN65	POM	FKM	GRAPHITE	PTFE	GRAPHITE	0,06	KMST9BHH
GM GN DN80	POM	FKM	GRAPHITE	PTFE	GRAPHITE	0,08	KMSTABHH
GM GN DN100	POM	FKM	GRAPHITE	PTFE	GRAPHITE	0,11	KMSTBBHH

SEALS KITS-CB

TYPE	BALL SEAT	O-RING	ADAPTER GASKET	STEM RING	STEM GASKET	Kg	KIT CODE
GM GN DN6	PTFE	NBR	GRAPHITE	PTFE	GRAPHITE	0,01	KMST1FHH
GM GN DN10	PTFE	NBR	GRAPHITE	PTFE	GRAPHITE	0,01	KMST2FHH
GM GN DN13	PTFE	NBR	GRAPHITE	PTFE	GRAPHITE	0,01	KMST3FHH
GM GN DN20	PTFE	NBR	GRAPHITE	PTFE	GRAPHITE	0,02	KMST4FHH
GM GN DN25	PTFE	NBR	GRAPHITE	PTFE	GRAPHITE	0,03	KMST5FHH
GM GN DN32	PTFE	NBR	GRAPHITE	PTFE	GRAPHITE	0,03	KMST6FHH
GM GN DN40	PTFE	NBR	GRAPHITE	PTFE	GRAPHITE	0,04	KMST7FHH
GM GN DN50	PTFE	NBR	GRAPHITE	PTFE	GRAPHITE	0,05	KMST8FHH

"The company reserves the right to operate dimensional changes without prior notice".

+ Seals kits

www.gemels.it

GM GN

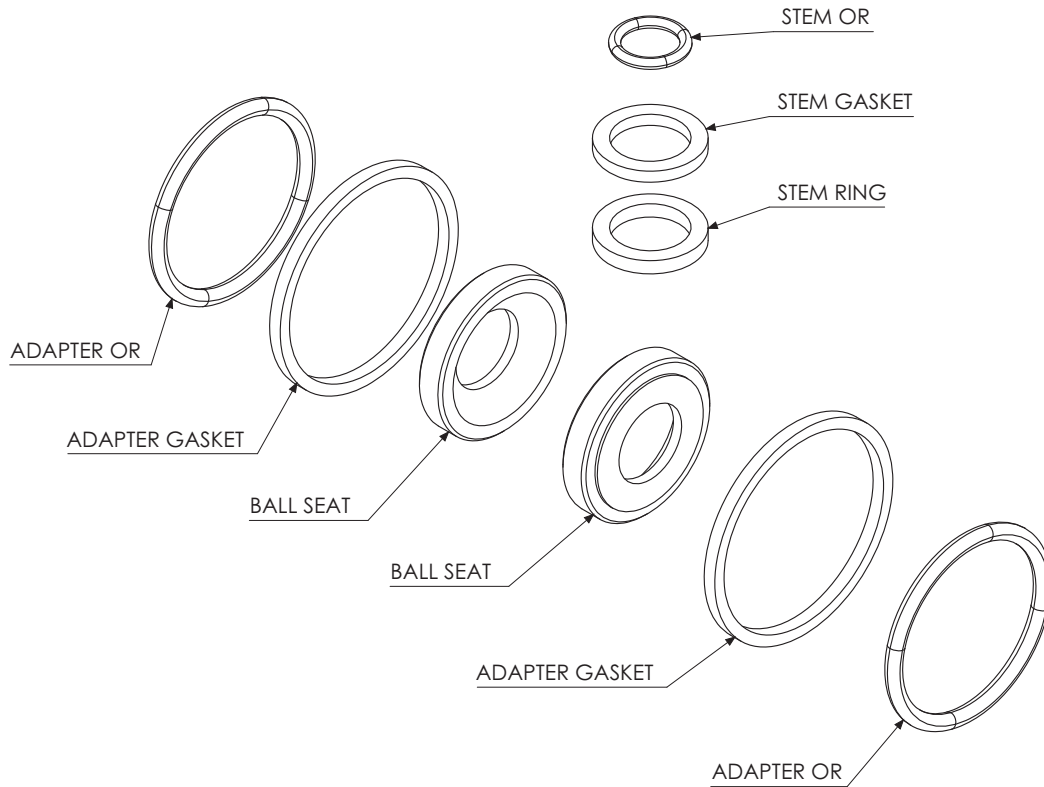

SEALS KITS-CE

TYPE	BALL SEAT	O-RING	ADAPTER GASKET	STEM RING	STEM GASKET	Kg	KIT CODE
GM GN DN6	PTFE	FKM	GRAPHITE	PTFE	GRAPHITE	0,01	KMST1GHH
GM GN DN10	PTFE	FKM	GRAPHITE	PTFE	GRAPHITE	0,01	KMST2GHH
GM GN DN13	PTFE	FKM	GRAPHITE	PTFE	GRAPHITE	0,01	KMST3GHH
GM GN DN20	PTFE	FKM	GRAPHITE	PTFE	GRAPHITE	0,02	KMST4GHH
GM GN DN25	PTFE	FKM	GRAPHITE	PTFE	GRAPHITE	0,03	KMST5GHH
GM GN DN32	PTFE	FKM	GRAPHITE	PTFE	GRAPHITE	0,03	KMST6GHH
GM GN DN40	PTFE	FKM	GRAPHITE	PTFE	GRAPHITE	0,04	KMST7GHH
GM GN DN50	PTFE	FKM	GRAPHITE	PTFE	GRAPHITE	0,05	KMST8GHH

SEALS KITS-KB

TYPE	BALL SEAT	O-RING	ADAPTER GASKET	STEM RING	STEM GASKET	Kg	KIT CODE
GM GN DN6	GEMPTFE	NBR	GRAPHITE	PTFE	GRAPHITE	0,01	KMST1LHH
GM GN DN10	GEMPTFE	NBR	GRAPHITE	PTFE	GRAPHITE	0,01	KMST2LHH
GM GN DN13	GEMPTFE	NBR	GRAPHITE	PTFE	GRAPHITE	0,01	KMST3LHH
GM GN DN20	GEMPTFE	NBR	GRAPHITE	PTFE	GRAPHITE	0,02	KMST4LHH
GM GN DN25	GEMPTFE	NBR	GRAPHITE	PTFE	GRAPHITE	0,02	KMST5LHH
GM GN DN32	GEMPTFE	NBR	GRAPHITE	PTFE	GRAPHITE	0,02	KMST6LHH
GM GN DN40	GEMPTFE	NBR	GRAPHITE	PTFE	GRAPHITE	0,03	KMST7LHH
GM GN DN50	GEMPTFE	NBR	GRAPHITE	PTFE	GRAPHITE	0,03	KMST8LHH
GM GN DN65	GEMPTFE	NBR	GRAPHITE	PTFE	GRAPHITE	0,06	KMST9LHH
GM GN DN80	GEMPTFE	NBR	GRAPHITE	PTFE	GRAPHITE	0,08	KMSTALHH
GM GN DN100	GEMPTFE	NBR	GRAPHITE	PTFE	GRAPHITE	0,11	KMSTBLHH

SEALS KITS-KE

TYPE	BALL SEAT	O-RING	ADAPTER GASKET	STEM RING	STEM GASKET	Kg	KIT CODE
GM GN DN6	GEMPTFE	FKM	GRAPHITE	PTFE	GRAPHITE	0,01	KMST1IHH
GM GN DN10	GEMPTFE	FKM	GRAPHITE	PTFE	GRAPHITE	0,01	KMST2IHH
GM GN DN13	GEMPTFE	FKM	GRAPHITE	PTFE	GRAPHITE	0,01	KMST3IHH
GM GN DN20	GEMPTFE	FKM	GRAPHITE	PTFE	GRAPHITE	0,02	KMST4IHH
GM GN DN25	GEMPTFE	FKM	GRAPHITE	PTFE	GRAPHITE	0,02	KMST5IHH
GM GN DN32	GEMPTFE	FKM	GRAPHITE	PTFE	GRAPHITE	0,02	KMST6IHH
GM GN DN40	GEMPTFE	FKM	GRAPHITE	PTFE	GRAPHITE	0,03	KMST7IHH
GM GN DN50	GEMPTFE	FKM	GRAPHITE	PTFE	GRAPHITE	0,03	KMST8IHH
GM GN DN65	GEMPTFE	FKM	GRAPHITE	PTFE	GRAPHITE	0,06	KMST9IHH
GM GN DN80	GEMPTFE	FKM	GRAPHITE	PTFE	GRAPHITE	0,08	KMSTAIHH
GM GN DN100	GEMPTFE	FKM	GRAPHITE	PTFE	GRAPHITE	0,11	KMSTBIHH

+ Seals kits

Specialist in Ball Valves

GPK

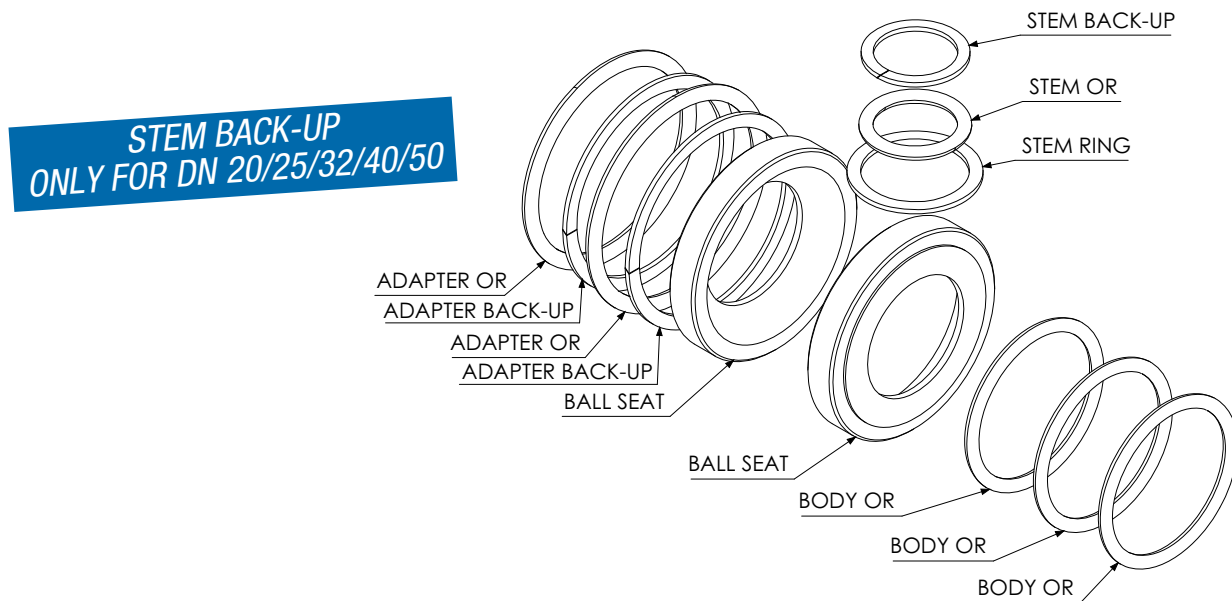

SEALS KITS-AB

TYPE	BALL SEAT	O-RING	ADAPTER BACK-UP	STEM RING	STEM BACK-UP	Kg	KIT CODE
GPK DN6	POM	NBR	PTFE	POM	PTFE	0	KPST1AHH
GPK DN10	POM	NBR	PTFE	POM	PTFE	0,01	KPST2AHH
GPK DN13	POM	NBR	PTFE	POM	PTFE	0,01	KPST3AHH
GPK DN20	POM	NBR	PTFE	POM	PTFE	0,01	KPST4AHH
GPK DN25	POM	NBR	PTFE	POM	PTFE	0,02	KPST5AHH
GPK DN32	POM	NBR	PTFE	POM	PTFE	0,02	KPST6AHH
GPK DN40	POM	NBR	PTFE	POM	PTFE	0,02	KPST7AHH
GPK DN50	POM	NBR	PTFE	POM	PTFE	0,02	KPST8AHH

SEALS KITS-AE

TYPE	BALL SEAT	O-RING	ADAPTER BACK-UP	STEM RING	STEM BACK-UP	Kg	KIT CODE
GPK DN6	POM	FKM	PTFE	POM	PTFE	0	KPST1BHH
GPK DN10	POM	FKM	PTFE	POM	PTFE	0,01	KPST2BHH
GPK DN13	POM	FKM	PTFE	POM	PTFE	0,01	KPST3BHH
GPK DN20	POM	FKM	PTFE	POM	PTFE	0,01	KPST4BHH
GPK DN25	POM	FKM	PTFE	POM	PTFE	0,02	KPST5BHH
GPK DN32	POM	FKM	PTFE	POM	PTFE	0,02	KPST6BHH
GPK DN40	POM	FKM	PTFE	POM	PTFE	0,02	KPST7BHH
GPK DN50	POM	NBR	PTFE	POM	PTFE	0,02	KPST8BHH

SEALS KITS-CB

TYPE	BALL SEAT	O-RING	ADAPTER BACK-UP	STEM RING	STEM BACK-UP	Kg	KIT CODE
GPK DN6	PTFE	NBR	PTFE	POM	PTFE	0,01	KPST1FHH
GPK DN10	PTFE	NBR	PTFE	POM	PTFE	0,01	KPST2FHH
GPK DN13	PTFE	NBR	PTFE	POM	PTFE	0,01	KPST3FHH
GPK DN20	PTFE	NBR	PTFE	POM	PTFE	0,02	KPST4FHH
GPK DN25	PTFE	NBR	PTFE	POM	PTFE	0,03	KPST5FHH
GPK DN32	PTFE	NBR	PTFE	POM	PTFE	0,02	KPST6FHH
GPK DN40	PTFE	NBR	PTFE	POM	PTFE	0,04	KPST7FHH
GPK DN50	PTFE	NBR	PTFE	POM	PTFE	0,02	KPST8FHH

SEALS KITS-CE

TYPE	BALL SEAT	O-RING	ADAPTER BACK-UP	STEM RING	STEM BACK-UP	Kg	KIT CODE
GPK DN6	PTFE	FKM	PTFE	POM	PTFE	0,01	KPST1GHH
GPK DN10	PTFE	FKM	PTFE	POM	PTFE	0,01	KPST2GHH
GPK DN13	PTFE	FKM	PTFE	POM	PTFE	0,01	KPST3GHH
GPK DN20	PTFE	FKM	PTFE	POM	PTFE	0,02	KPST4GHH
GPK DN25	PTFE	FKM	PTFE	POM	PTFE	0,03	KPST5GHH
GPK DN32	PTFE	FKM	PTFE	POM	PTFE	0,02	KPST6GHH
GPK DN40	PTFE	FKM	PTFE	POM	PTFE	0,04	KPST7GHH
GPK DN50	PTFE	FKM	PTFE	POM	PTFE	0,02	KPST8GHH

"The company reserves the right to operate dimensional changes without prior notice".

+ Seals kits

www.gemels.it

SEALS KITS-DB

TYPE	BALL SEAT	O-RING	ADAPTER BACK-UP	STEM RING	STEM BACK-UP	Kg	KIT CODE
GPk DN6	PEEK	NBR	PTFE	PEEK	PTFE	0	KPST1PHH
GPk DN10	PEEK	NBR	PTFE	PEEK	PTFE	0,01	KPST2PHH
GPk DN13	PEEK	NBR	PTFE	PEEK	PTFE	0,01	KPST3PHH
GPk DN20	PEEK	NBR	PTFE	PEEK	PTFE	0,01	KPST4PHH
GPk DN25	PEEK	NBR	PTFE	PEEK	PTFE	0,02	KPST5PHH
GPk DN32	PEEK	NBR	PTFE	PEEK	PTFE	0,02	KPST6PHH
GPk DN40	PEEK	NBR	PTFE	PEEK	PTFE	0,02	KPST7PHH
GPk DN50	PEEK	NBR	PTFE	PEEK	PTFE	0,02	KPST8PHH

SEALS KITS-DE

TYPE	BALL SEAT	O-RING	ADAPTER BACK-UP	STEM RING	STEM BACK-UP	Kg	KIT CODE
GPk DN6	PEEK	FKM	PTFE	PEEK	PTFE	0	KPST1NHH
GPk DN10	PEEK	FKM	PTFE	PEEK	PTFE	0,01	KPST2NHH
GPk DN13	PEEK	FKM	PTFE	PEEK	PTFE	0,01	KPST3NHH
GPk DN20	PEEK	FKM	PTFE	PEEK	PTFE	0,01	KPST4NHH
GPk DN25	PEEK	FKM	PTFE	PEEK	PTFE	0,02	KPST5NHH
GPk DN32	PEEK	FKM	PTFE	PEEK	PTFE	0,02	KPST6NHH
GPk DN40	PEEK	FKM	PTFE	PEEK	PTFE	0,02	KPST7NHH
GPk DN50	PEEK	FKM	PTFE	PEEK	PTFE	0,02	KPST8NHH

SEALS KITS-GB

TYPE	BALL SEAT	O-RING	ADAPTER BACK-UP	STEM RING	STEM BACK-UP	Kg	KIT CODE
GPk DN6	PA612	NBR	PTFE	PA612	PTFE	0	KPST1THH
GPk DN10	PA612	NBR	PTFE	PA612	PTFE	0,01	KPST2THH
GPk DN13	PA612	NBR	PTFE	PA612	PTFE	0,01	KPST3THH
GPk DN20	PA612	NBR	PTFE	PA612	PTFE	0,01	KPST4THH
GPk DN25	PA612	NBR	PTFE	PA612	PTFE	0,02	KPST5THH
GPk DN32	PA612	NBR	PTFE	PA612	PTFE	0,02	KPST6THH
GPk DN40	PA612	NBR	PTFE	PA612	PTFE	0,02	KPST7THH
GPk DN50	PA612	NBR	PTFE	PA612	PTFE	0,02	KPST8THH

SEALS KITS-GE

TYPE	BALL SEAT	O-RING	ADAPTER BACK-UP	STEM RING	STEM BACK-UP	Kg	KIT CODE
GPk DN6	PA612	FKM	PTFE	PA612	PTFE	0	KEST1DHH
GPk DN10	PA612	FKM	PTFE	PA612	PTFE	0,01	KEST2DHH
GPk DN13	PA612	FKM	PTFE	PA612	PTFE	0,01	KEST3DHH
GPk DN20	PA612	FKM	PTFE	PA612	PTFE	0,01	KEST4DHH
GPk DN25	PA612	FKM	PTFE	PA612	PTFE	0,02	KEST5DHH
GPk DN32	PA612	FKM	PTFE	PA612	PTFE	0,02	KPST6DHH
GPk DN40	PA612	FKM	PTFE	PA612	PTFE	0,02	KPST7DHH
GPk DN50	PA612	FKM	PTFE	PA612	PTFE	0,02	KPST8DHH

SEALS KITS-KB

TYPE	BALL SEAT	O-RING	ADAPTER BACK-UP	STEM RING	STEM BACK-UP	Kg	KIT CODE
GPk DN6	GEMPTFE	NBR	PTFE	POM	PTFE	0	KPST1LHH
GPk DN10	GEMPTFE	NBR	PTFE	POM	PTFE	0,01	KPST2LHH
GPk DN13	GEMPTFE	NBR	PTFE	POM	PTFE	0,01	KPST3LHH
GPk DN20	GEMPTFE	NBR	PTFE	POM	PTFE	0,01	KPST4LHH
GPk DN25	GEMPTFE	NBR	PTFE	POM	PTFE	0,02	KPST5LHH
GPk DN32	GEMPTFE	NBR	PTFE	POM	PTFE	0,02	KPST6LHH
GPk DN40	GEMPTFE	NBR	PTFE	POM	PTFE	0,02	KPST7LHH
GPk DN50	GEMPTFE	NBR	PTFE	POM	PTFE	0,02	KPST8LHH

SEALS KITS-KE

TYPE	BALL SEAT	O-RING	ADAPTER BACK-UP	STEM RING	STEM BACK-UP	Kg	KIT CODE
GPk DN6	GEMPTFE	FKM	PTFE	POM	PTFE	0	KPST1IHH
GPk DN10	GEMPTFE	FKM	PTFE	POM	PTFE	0,01	KPST2IHH
GPk DN13	GEMPTFE	FKM	PTFE	POM	PTFE	0,01	KPST3IHH
GPk DN20	GEMPTFE	FKM	PTFE	POM	PTFE	0,01	KPST4IHH
GPk DN25	GEMPTFE	FKM	PTFE	POM	PTFE	0,02	KPST5IHH
GPk DN32	GEMPTFE	FKM	PTFE	POM	PTFE	0,02	KPST6IHH
GPk DN40	GEMPTFE	FKM	PTFE	POM	PTFE	0,02	KPST7IHH
GPk DN50	GEMPTFE	FKM	PTFE	POM	PTFE	0,02	KPST8IHH

+ Seals kits

Specialist in Ball Valves

2014 - Edition 2

GV

**STEM BACK-UP
ONLY FOR DN 20/25/32**

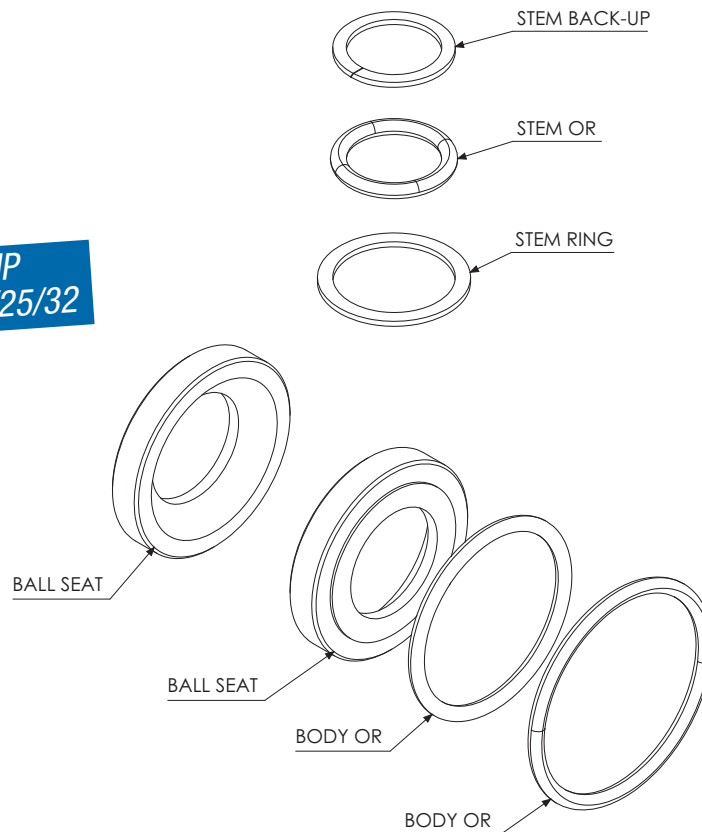

SEALS KITS-AE

TYPE	BALL SEAT	O-RING	STEM RING	STEM BACK-UP	Kg	KIT CODE
GV DN6	POM	VITON	POM	PTFE	0	KVST1AHH
GV DN10	POM	VITON	POM	PTFE	0,01	KVST2AHH
GV DN13	POM	VITON	POM	PTFE	0,01	KVST3AHH
GV DN20	POM	VITON	POM	PTFE	0,01	KVST4AHH
GV DN25	POM	VITON	POM	PTFE	0,02	KVST5AHH
GV DN32	POM	VITON	POM	PTFE	0,02	KVST6AHH

SEALS KITS-GE

TYPE	BALL SEAT	O-RING	STEM RING	STEM BACK-UP	Kg	KIT CODE
GV DN6	PA612	VITON	PA612	PTFE	0	KVST1DHH
GV DN10	PA612	VITON	PA612	PTFE	0,01	KVST2DHH
GV DN13	PA612	VITON	PA612	PTFE	0,01	KVST3DHH
GV DN20	PA612	VITON	PA612	PTFE	0,01	KVST4DHH
GV DN25	PA612	VITON	PA612	PTFE	0,02	KVST5DHH
GV DN32	PA612	VITON	PA612	PTFE	0,02	KVST6DHH

TECH

MATERIAL



TECH
MATERIAL

KITS
LOCKING - HANDLES
FLANGE - LIMIT SWITCHES
ACTUATORS - SEALS KITS

OIL&GAS
GM1-GM - GN
SBF - SBT

OTHER
GHP - GPS - RF
BD - VU - VUBA

GR
GRC - GRS

GPK
GPK2 - GPK3

G3K-4K
G3K - G4K

GV
GV2 - GV3

GB
GB2 - GB3 - GBF
GBS - GBC

GE
GEM - GE1 - GE2 - GE3
GE5 - GE3K - GEF
GES - GEC - GEV

Resistenza chimica dei materiali ai fluidi



Storia

La scoperta dell'acciaio inossidabile si deve all'inglese Harry Brearly nel 1913, sperimentando acciai per canne di armi da fuoco scoprì che un provino di acciaio con il 13-14% di cromo e con un tenore di carbonio relativamente alto che aveva preparato non arrugginiva quando era esposto all'atmosfera. Successivamente questa proprietà venne spiegata con la passivazione del cromo, che forma sulla superficie una pellicola di ossido estremamente sottile, continua e stabile; per questo l'acciaio inox resiste alla corrosione sia in ambiente umido che asciutto. Non solo; gli acciai inox offrono anche molte proprietà secondarie che li rendono materiali di grande versatilità. I successivi progressi della metallurgia fra gli anni '40 e '60 hanno ampliato il loro sviluppo e le loro applicazioni. Tuttora vengono perfezionati e adattati alle richieste dei vari settori industriali, come il petrolifero/petrochimico, minerario, energetico, nucleare ed alimentare.

Tipi di acciaio inossidabile

Il termine acciaio inossidabile (o inox) indica genericamente gli acciai ad alta lega contenenti cromo, generalmente in quantità fra l'11 ed il 30%; altri leganti che aumentano la resistenza alla corrosione sono nichel, molibdeno, rame, titanio e niobio: in ogni caso, perchè si possa parlare propriamente di acciaio, il totale degli elementi leganti non deve superare il 50%. I componenti questa famiglia di acciai sono classificati secondo la loro struttura microcristallina che deriva dalla loro diversa composizione chimica.

Materials resistance to fluids



History

Stainless steel was discovered by the English Harry Brearly in 1913. By experimenting steel for the construction of weapons pipes, he discovered that a kind of steel with a percentage of 13%-14% of chrome and with a relatively high level of carbon did not rust even when exposed to the atmosphere. Later on, this property was explained with the passivity of chrome, that creates on its surface an extremely thin, continuous and stable oxide layer. For this reason stainless steel resists to corrosion both in the humid and dry environment. Furthermore, stainless steel offers a wide variety of secondary properties that make it a versatile material.

The following progress in the field of metallurgy between the '40 and '60 widened the range of uses and applications of stainless steel. It is still improved and adapted to the requests of the different industrial sectors, like the petrochemical, mining, energy, nuclear and food.

Types of Stainless Steel

The term Stainless Steel indicates a high alloy steel containing chrome, generally in a 13 to 30% quantity. Other substances that increase corrosion resistance are nickel, molybdenum, copper, titanium, and niobium. In any case, to properly talk about stainless steel the total quantity of these elements should not exceed 50%. These steel components are classified with reference to their microcrystalline structure that comes from their different chemical composition.

Resistenza chimica dei materiali ai fluidi

	Steel	Stainless Steel
A		
Acetaldeide 40%	–	–
Acetammide 50%	–	–
Acetato butilico	–	–
Acetato metilico	–	–
Acetato di etile	B	B
Acetilene	A	A
Aceto	C	A
Acetone	A	A
Acidi grassi 100°C	C	A
Acidi grassi 200°C	C	A
Acido acetico concentrato	B	A
Acido acetico, acquoso al 10%	–	–
Acido acetico, acquoso al 5%	–	–
Acido borico, acquoso al 10%	–	B
Acido citrico, acquoso al 10%	C	B
Acido cloridrico, acquoso al 36%	–	–
Acido cloridrico, acquoso al 10%	–	–
Acido cloridrico, acquoso al 2%	–	–
Acido di cromo 10%	–	B
Acido fluoridrico, 40%	–	–
Acido formico, acquoso al 10%	C	A
Acido fosforico, acquoso al 10%	–	A
Acido fosforico concentrato	–	A
Acido glicolico	–	A
Acido idroclorico 36%	–	–
Acido idroclorico 2%	–	A
Acido idrofluorico	–	–
Acido lattico, acquoso al 10%	–	–
Acido lattico, acquoso al 90%	–	–
Acido nitrico, acquoso 2%	B	A
Acido nitrico, concentrato 65%	B	B
Acido oleico 100°C	B	A
Acido oleico 200°C	–	A
Acido ossalico, acquoso al 10%	–	–
Acido salicilico	–	–
Acido solforico, conc. al 98%	B	B
Acido solforico, conc. al 10%	–	–
Acido solforico, Acquoso al 2%	B	A
Acido tartarico	–	–
Acqua calda	C	C
Acqua clorica	–	A
Acqua di mare	–	A
Acqua, fredda	C	C
Acqua ossigenata 10%	–	–
Acqua ossigenata 3%	–	–

Materials resistance to fluids

	Steel	Stainless Steel
A		
Acetamide 50%	–	–
Acetic acid conc.	B	A
Acetic acid 10%	–	–
Acetic acid 5%	–	–
Acetic acid ethyl ester	B	A
Acetone	A	A
Acetylene (ethin)	A	A
Air	A	A
Ammonium chloride	C	A
Ammonia 10%	A	A
Amyl Alcohol	–	A
Aniline	B	A
Argon, gaseous	A	A
ATE brake fluid	A	A
B		
Beer	–	A
Beet sugar juice	B	A
Benzene	A	A
Benzine, leaded	A	A
Bitumen	A	A
Borax	B	B
Boric acid 10%	–	B
Brine	B	A
Bromine	–	A
Butane	A	A
Butylacetate	–	–
Butylene glycol	–	–
C		
Calcium chloride 10%	–	B
Carbon dioxide, dry	A	A
Carbon dioxide, wet	A	A
Carbon disulphide	–	–
Carbonlineum	–	–
Carbon tetrachloride	–	–
Chlorine 100°C	B	B
Chlorine water	–	A
Chlorobenzene	–	–
Chloroform	B	A
Chromic acid	–	B
Citric acid 10%	C	B
Clophen A 80 50%	–	–
Coconut oil	–	B
Coffee	–	B

	Steel	Stainless Steel
Acqua ossigenata 1%	-	-
Acqua ossigenata 0,5%	-	-
Acrilnitrile	-	-
Alcol allilico	-	-
Alcol amilico	-	A
Alcol benzilico	-	-
Alcol isopropilico (fino a 48° C)	B	B
Allume di cromo 10%	-	-
Ammoniaca, acquoso al 10%	A	A
Anilina	B	A
Anone	-	-
Aria	A	A
Argon	A	A

B

Benzaldeide (Fino a 22°C)	-	-
Benzene	A	A
Benzina	A	A
Benzolo	-	-
Benzolo di cloro	-	-
Bicromato potassico, acquoso al 10%	-	-
Birra	-	A
Bisolfito di sodio, acquoso al 10%	-	-
Bitume	A	A
Butanolo	-	-
Butilacetato	-	-

C

Caffè	-	A
Carbonato di potassio	-	A
Carbonato di sodio, acquoso al 10%	-	A
Catrame	A	A
Cera fusa	A	A
Chetone etimetilico	-	-
Cicloesano	B	A
Cicloesanone	-	-
Clofene A 80 50%	-	-
Clorobenzolo	-	-
Cloroformio	B	A
Cloruro di alluminio	C	A
Cloruro di ammonio	C	A
Cloruro di calcio, acquoso al 10%	-	B
Cloruro di calcio, alcolico	-	B
Cloruro di etile	-	-
Cloruro di etilene	-	-
Cloruro di ferro	C	A
Cloruro di magnesio	B	B
Cloruro di metilene	B	A
Cloruro di sodio, acquoso al 10%	B	B
Cloruro di zinco, acquoso al 10%	-	-

	Steel	Stainless Steel
Copper sulphate	-	-
Cyclohexane	-	-
Cyclohexanol	B	A
Cyclohexanone	-	-

D

Diacetone alcohol	-	A
Diesel oil	A	A
Dichlorbenzene	-	A
Diethylene glycol	B	A
Dimethylformamide	-	-
Dimethyl Ketone (acetone)	B	A
Dioctylphthalate	-	-
Dioxan	-	-

E

Edible oil, Edible fat	-	-
Ethandiol	B	A
Ethane	B	B
Ethanol 96%	B	A
Ether	A	A
Ethyl Acetate	B	B
Ethyl alcohol	B	A
Ethyl benzene	A	A
Ethylene	B	A
Ethylene glycole	B	A
Ethylene trichloride (Tri)	B	A
Ethylene Chloride	-	-

F

Fatty acids 100°C	C	A
Fatty acids 200°C	C	A
Ferric chloride	C	A
Flue gas	B	A
Formaldehyde 30%	C	A
Formamide	-	-
Formic acid 10%	C	B
Freon 11,13,14,32	B	A
Freon 22,31,114,115	B	A
Frigen	-	-
Fruit juices	C	A
Fuel oil	B	A

G

Gasoline	A	A
Gelatine	-	A
Glucose	B	A
Glycerine	B	A
Glycol	B	A
Glycol acids	-	A

+ TECH TECHNICAL SHEETS

www.gemels.it

	Steel	Stainless Steel
Combustibile diesel	A	A
Decalina	-	-
Diactiftalato	-	-
Diammina di etilene	-	-
Dimetilformammide	-	-
Diossano	-	-
Diossido di carbonio, secco	A	A
Diossido di carbonio, umido	A	A

E

Elio, gassoso	A	A
Eptano,	B	A
Esano	B	B
Etanolo 96%	B	A
Etere di etile	-	-
Etilacetato	B	B
Etiletere	-	-

F

Fenolo, acquoso	-	A
Formaldeide, acquoso al 30%	C	A
Formammide	-	-
Freon, frigen, liquido	B	A
Ftalato dibutilico	-	-
Ftalato dioctilico	-	-
Furfurolo	-	-

G

Gas clorico	-	-
Gasolio	A	A
Gelatina	-	A
Glicerina	B	A
Glicole	B	A
Glisantina, acquosa al 40%	-	-
Glucosio	B	A
Grassi alimentari, oli alimentari	A	A

I

Idrogeno solforato, saturo	-	-
Idrossido di potassio, acquoso al 10%	-	-
Idrossido di potassio, acquoso al 50%	-	-
Idrossido di sodio 50%	B	B
Idrossido di sodio 10%	B	A
Inchiostro	C	A
Isopropranololo	-	-
Isottano	A	A

K

Kerosene	B	A
----------	---	---

	Steel	Stainless Steel
Glystantin 40%	-	-
Grease	A	A

F

Helium, gaseous	A	A
Heptane	B	A
Hexane	B	B
Hydrochloric acid 36%	-	-
Hydrochloric acid 2%	-	A
Hydrofluoric acid	-	-
Hydrogen peroxide 30%	C	B
Hydrogen peroxide 0,5%	-	-
Hydrogen sulphide	-	-

I

Ink	C	A
Isobutylalcohol	B	B
Isocyanat	A	A
Isooctane	A	A
Isopropanol	-	-
Isopropylalcohol	B	B

K

Kerosene	B	A
----------	---	---

L

Lactic acid 90%	-	-
Lactic acid 10%	-	-
Linseed oil	A	B

M

Magnesium chloride	B	B
Margarine	-	A
Menthol	-	B
Mercury	A	A
Mercury dichloride	-	B
Mercury monochloride	-	B
Methane	A	A
Methanol	B	A
Methyl ethyl ketone	-	-
Methylene chloride	B	A
Milk	-	A
Motor oil/Engine oil	-	-

N

Naphta (stone-oil)	B	A
Naphtalene	B	B
Neon, gaseous	A	A
Nitric acid 2%	B	B

	Steel	Stainless Steel
L		
Latte	-	A
M		
Margarina	-	A
Mentolo	-	B
Mercurio	A	A
Mercurio acquoso	A	A
Metano	A	A
Metanolo	B	A
Metiltilchetone	-	-
N		
Nitrato di potassio	-	-
Nafta pesante	B	A
Naftalina	B	B
Neon	A	A
Nitrato di sodio, acquoso al 10%	B	A
Nitrobenzolo	B	A
O		
Oli siliconici	A	A
Olio di cocco	-	B
Olio di lino	A	A
Olio di oliva	A	A
Olio di paraffina	-	A
Olio di soia	A	A
Olio minerale	A	A
Olio per trasformatori	-	-
Ossigeno, gassoso 60°C	B	A
Ottani	-	A
Ozono	B	A
P		
Pectina	-	A
Percloroetilene	A	A
Permanganato potassico, acquoso al 1%	-	-
Perossido di idrogeno, acquoso al 30%	C	B
Perossido d'idrogeno, acquoso al 0,5%	-	-
Petrolio	A	A
Piridina	-	-
Potassa caustica acquosa 10%	-	-
Potassa caustica acquosa 50%	-	-
Propano	B	A
Propanolo	-	-
Propilene	-	-
S		
(m) solfato rameico 10%	-	-
Sego	-	-

	Steel	Stainless Steel
Nitrobenzene	B	A
O		
Octane	-	A
Oleic acid 100°C	B	A
Oleic acid 200°C	-	A
Olive oil	A	A
Oxygen, gaseous 60°C	B	A
Oxalic acid 10%	-	-
Ozone	B	A
P		
Paraffin oil	-	A
Pectin	-	A
Perchloroethylene	A	A
Petroleum white spirit	A	A
Phenol, aqueous	-	A
Phosphoric acid 10%	-	A
Potassium carbonate	-	A
Potassium hydroxide solution 50%	-	-
Potassium hydroxide solution 10%	-	-
Potassium dichromate 10%	-	-
Potassium permanganate 1%	-	-
Potassium sulphate	B	B
Propane	B	A
Propanol	-	-
Propylene	A	A
Pyridene	-	-
P-3 Solution aqueous	-	-
S		
Salicylic acid		
Sea water	-	A
Silicone oil	A	A
Soap solution	-	-
Soda solution 10%	-	-
Sodium bisulphite	-	-
Sodium carbonate 10%	-	A
Sodium Chloride 10%	B	B
Sodium Hydroxide solution 50%	B	B
Sodium Hydroxide solution 10%	B	A
Sodium nitrate 10%	B	A
Sodium thiosulphate	B	A
Solvent	A	A
Soybean-oil	A	A
Steam 150°C	B	A
Styrene	-	-
Sulphuric acid 98%	B	B
Sulphuric acid 2%	B	A

+ TECH TECHNICAL SHEETS

www.gemels.it

	Steel	Stainless Steel
Soda caustica, acquosa al 5%	-	-
Soda caustica, acquosa al 10%	-	-
Soda caustica, acquosa al 50%	-	-
Solfato di potassio	B	B
Solfuro di alluminio	-	-
Solfuro di carbonio	-	-
Solfuro di idrogeno	-	-
Solfuro di manganese	-	-
Solfuro di rame	-	-
Solfuro di sodio	-	-
Soluzione alcalina 0,1% cloro attivo	-	-
Soluzione P-3, acquoso	-	-
Soluzione saponata, acquosa	-	-
Solvente	A	A
Stirol	-	-
Succhi di frutta	C	A

T		
Tar	A	A
Tetracloruro di carbonio	-	-
Tetraidrofuran	-	-
Tetralina	-	-
Tintura di iodio, alcolica	-	-
Tiosolfato di sodio, acquoso al 10%	-	-
Toluolo	-	-
Tricloroetilene	A	A
Trietanolanmina	-	-
Trilon B, acquoso al 10%	-	-
Turpentina	B	A

U		
Urea, acquoso	-	B

V		
Vaselina	B	A
Vapore, 150°C	B	A
Vino, acquavite	C	A

X		
Xilolo	B	A

LEGENDA	
A	Resistente
B	Parzialmente resistente
C	Non resistente
-	Non disponibile

Tutti i dati si riferiscono ad una temperatura di 20°C e sono indicativi. Questi dati corrispondono allo stato attuale delle nostre conoscenze, e hanno lo scopo di informare sui nostri prodotti e sulle possibili applicazioni. Non hanno, tuttavia, una garanzia legalmente vincolante della resistenza chimica o l'idoneità per una specifica applicazione. Brevetti commerciali esistenti devono essere tenuti in considerazione. Test standard sono effettuati in atmosfera condizionata standard 23/50 secondo DIN 50014. Per applicazioni specifiche si raccomanda un test pratico per l'idoneità.

"The company reserves the right to operate dimensional changes without prior notice".

	Steel	Stainless Steel
T		
Tar	A	A
Tartaric acid	-	-
Tetrahydrofuran	-	-
Tetrahydronaphthalene	-	-
Thermo-oil 200°C	A	A
Thermo-oil 250°C	A	A
Tincture of iodine	-	-
Toluene	A	A
Triethanolamine	-	-
Trichloroethylene	A	A
Trilon B 10%	-	-
Turpentine	B	A

U		
Urea aqueous	-	B

V		
Vaseline	B	A
Vegetable oil	-	A
Vinegar (5...10% feed vinegar)	C	A
Vinyl chloride	B	B

W		
Water, cold	C	A
Water, distilled	A	A
Water, hot	C	A
Wax, molten	A	A
Wine, brandy	C	A

X		
Xylene	B	A

Z		
Zinc chloride 10%	C	B

LEGEND	
A	Resistant
B	Limited resistance
C	Not resistant
-	Data not available

All the data refer to a temperature of 20°C and are not binding. These data represent the state of the art of our knowledge, and have the scope of giving information on our products and their possible applications. These data have not a legally binding guarantee regarding the chemical resistance and the suitability for a specific application. Standard tests are done in a standard conditioned atmosphere 23/50 as stated in DIN 50014. For any specific applications we recommend a practical test for the suitability.

Resistenza degli o-ring ai fluidi

Temperatura di lavoro minima e massima ammissibile per gli o-rings

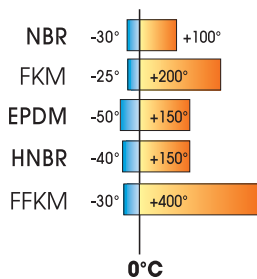

PRINCIPI GENERALI O-RINGS

La semplice geometria è la principale caratteristica di un O-Ring che, assieme alla scelta di un adeguato elastomero risulta un sistema di tenuta efficiente, a basso costo e facile da usare. I Materiali elastomerici, quando compressi, reagiscono come un fluido ad alta viscosità che trasmette la

pressione applicata in ogni direzione; di conseguenza, l'O-Ring agisce da barriera, bloccando le perdite tra le superfici delle guarnizioni. I sistemi di tenuta tecnici sono stati definiti dal DIN standard come segue:

- **“Guarnizione statica”**. Azione creata dalla guarnizione tra due corrispondenti superfici senza fuoriuscite di liquido o minima diffusione di gas;
- **“Guarnizioni dinamiche”**. Le superfici contrapposte hanno un lieve movimento con una minima perdita di liquido (Che è utile per mantenere l'efficienza della guarnizione, agendo da lubrificante).

Gli O-Rings offrono diversi vantaggi rispetto altri sistemi di guarnizioni: semplicità di costruzione, ampia selezione di materiali, dimensioni standardizzate, adattabilità sia per applicazioni dinamiche che statiche, dimensioni standard delle sedi, basso costo dovuto ad alte quantità di produzione. La tenuta è sempre raggiunta attraverso una compressione, che risulta in una deformazione della sezione dell'O-Ring. La resistenza alla compressione è la caratteristica più importante dell'O-Ring.

DETERMINAZIONE DEI GRUPPI DI MATERIALI

NBR (Elastomero acrilonitrile butadiene):

Grazie alla sua buona resistenza alla maggior parte degli oli e grassi su base di olio minerale, l'NBR è il materiale impiegato più spesso nella tecnologia delle tenute. Il campo di utilizzazione termica è normalmente compreso tra -30°C e +100°C, per un breve tempo +130°C. Miscele speciali di NBR sono utilizzabili fino a -55°C. Il contenuto di acrilonitrile può essere compreso tra il 18% e 50%. I contenuti più frequenti vanno dal 28% al 38%. Con l'aumentare del contenuto migliora la resistenza agli oli e grassi minerali, ma contem-

O-rings resistance to fluids

Maximum and minimum admissible working temperatures for o-rings

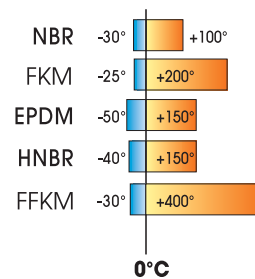

GENERAL PRINCIPLES (O-RINGS)

The simple geometry is the main characteristic of an O-Ring which, in conjunction with proper elastomer selection results in a low cost, easy to use and efficient sealing system. Elastomeric materials, when compressed, react like a high viscosity fluid

which transmits applied stress in every direction; consequently, the O-Ring serves as a barrier, blocking the leak paths between the sealing surfaces. Technical sealing has been defined by DIN Standards as follows:

- **“Static seal”** - The sealing action created between two mating surfaces with no leakage of liquid or minimal diffusion of gas;
- **“Dynamic seal”** - The mating surfaces have relative movement with minimal leakage of liquid (useful to protect the sealing efficiency, acting as lubricant).

O-Rings offer several advantages over other sealing systems: simplicity of construction, standardized seal dimensions, wide selection of materials, suitability for both static and dynamic applications, standard dimensioning of glands, low cost due to high volume manufacturing. Sealing is always achieved through a positive compression or squeezing action, resulting in a deformation of the O-Ring cross-section. The most important sealing characteristic of an O-Ring is its resistance to compression set or residual deformation.

DETERMINATION OF THE MATERIALS GROUP

NBR (Acrylonitrile butadiene elastomer):

This material is the most often used in sealing technology because of its good resistance to the majority of mineral oil-based oils and greases. Its normal temperature range is between -30°C and +100°C, with short periods at +130°C. Special NBR compounds can be used as low as -55°C. The acrylonitrile content may be between 18% and 50%. The most common proportion is 28% to 38%. As this proportion rises the resistance to minerals oils and greases increases, but at the same time the flexibility and low-temperature



poraneamente si riduce la flessibilità e con questo la resistenza alle basse temperature. La deformazione residua a compressione aumenta col contenuto di acrilonitrile.

FKM (Elastomero fluorurato):

FKM si distingue per la sua elevata resistenza alla temperatura, alle intemperie, all'ozono ed alle sostanze chimiche. Il campo d'utilizzazione termica arriva fino a +200°C, per breve tempo a +250°C.

L'FKM è altamente resistente a quasi tutti i fluidi idraulici su base di olio minerale e sintetico. Alcuni limiti per l'impiego si riscontrano nell'utilizzo dell'FKM con acqua calda, vapore ed a basse temperature. A causa della limitata flessibilità a freddo ed alla piccola resistenza all'acqua calda ed al vapore, per questo impiego si devono scegliere dei materiali speciali.

MVQ (Elastomero al silicone):

MVQ si distingue specialmente per il vasto campo termico di applicazione. Degli ulteriori vantaggi sono la flessibilità a freddo molto buona, la resistenza all'ozono e le buone proprietà dielettriche. La penetrabilità ai gas è peggiore di quella di altri elastomeri. La temperatura d'impiego è compresa tra -60°C e +200°C, per breve tempo +250°C.

EPDM (Elastomero etilene-propilene):

Gli elastomeri EPDM sono molto resistenti all'ozono, all'invecchiamento ed alle intemperie. È molto buona anche la resistenza all'acqua fredda, calda e al vapore. Gli EPDM non resistono agli oli a grassi minerali. Buona è la loro compatibilità con sostanze chimiche. La temperatura d'impiego è compresa tra -40°C e +160°C, per breve tempo fino a +180°C.

FFKM (Elastomero perfluorato)

L'FFKM possiede la stessa resistenza chimica del RPTFE e le caratteristiche elastiche dell'elastomero fluorurato FKM. Si distingue per un'elevata resistenza alla temperatura, all'ozono, alle intemperie ed all'invecchiamento. Il campo d'impiego termico arriva fino a +315°C, per breve tempo fino a +350°C. Nel campo di temperature al di sopra dei +200°C, l'FFKM evidenzia una deformazione residua alla compressione molto bassa e costante.



resistance reduces. The compression set rises as the acrylonitrile content increases.

FKM (Fluoroelastomer)

FKM has an outstanding resistance to high temperatures, ozone, chemicals and weathering. The operating range is up to +200°C, and +250°C for brief periods. FKM is highly resistant to almost all synthetic hydraulic fluids and those based on mineral oils. FKM is less suitable for use in hot water, steam and at low temperatures. Their low-temperature flexibility is only slight and their resistance to hot water and steam is moderate. Special materials should be selected for these applications.

MVQ (Silicone elastomer)

The principal feature of MVQ is its wide temperature range. Its very good low-temperature flexibility, good ozone resistance and good electrical properties are other advantages. Its gas permeability is not as good as that of other elastomers. Operating temperatures are between -60°C and +200°C, up to +250°C for short periods.

EPDM (Ethylene-propylene diene elastomer)

EPDM elastomers have a very good resistance to ozone, ageing and weathering, also to water, hot water and steam. They are not resistant to mineral oils and greases. Their compatibility with chemicals is good. Operating temperatures are between -40°C and +160°C, up to +180°C for short periods.

FFKM (Perfluoroelastomer)

FFKM has almost the same chemical resistance as RPTFE, plus elastic properties of the fluoroelastomer FKM, and it also has outstanding resistance to high temperatures, ozone, weathering and ageing. The range of service temperatures goes up to +315°C and +350°C for short periods. In the temperature range above +200°C FFKM has a very low and constant compression set.

Resistenza degli o-ring ai fluidi

	NBR	FKM	MQV	EPDM	FFKM
A					
Acetaldeide	C	D	B	B	A(1)
Acetamide	A	C	B	A	A(1)
Acetato d'alluminio	B	D	D	A	A
Acetato d'amile	D	D	D	A	A
Acetato d'etile	D	D	B	B	A
Acetato di butile	D	D	D	B	A
Acetato di calcio	B	D	D	A	A
Acetato di cellosolve	D	D	D	B	A
Acetato di metile	D	D	D	B	A
Acetato di nichel	B	D	D	A	A
Acetato di n-propile	D	D	D	A	A
Acetato di piombo	B	D	D	A	B
Acetato di potassio	B	D	D	A	A
Acetato di propile	D	D	D	B	A
Acetato di rame	B	D	D	A	A
Acetato di sodio	B	D	D	A	A
Acetato di vinile	A	A	B	A	A
Acetato di zinco	B	D	D	A	A
Acetato di isopropilico	D	D	D	B	A
Acetilene, Etere	A	A	B	A	A
Aceto (sol. acquosa 5% di acido acetico)	B	A	A	A	A
Acetoacetato di metile	D	D	B	B	A
Acetofenone	D	D	D	A	A
Acetone	D	D	D	A	A
Acetone acetilico	D	D	D	A	A
Acetone clorico	D	D	D	A	A
Acidi grassi	B	A	B	C	A
Acido acetico					
Concentrato (glaciale)	B	D	B	B	A
Caldo	D	D	C	C	A
Glaciale (acido acetico 100%)	B	D	B	B	A
Triclorato	B	C	C	B	A
Acido arsenico (tricloruro d'arsenico)	A	A	A	A	A
Acido benzoico	D	A	D	B	A
Acido benzosolfonico 10%	D	A	D	D	A
Acido borico	A	A	A	A	A
Acido butirrico	D	B	D	B	A
Acido carbonico	B	A	A	A	A
Acido citrico	A	A	A	A	A
Acido cloracetico	D	D	D	B	A
Acido cloridrico 3 molare	C	A	D	A	A
Acido colfosforoso concentrato	D	A	D	C	A
Acido creosico	D	D	D	D	A
Acido etilacrilico	D	A	D	D	-
Acido fenico (Fenolo)	D	-	D	B	A1
Acido fluorico					
≤ 65% freddo	D	A	D	D	A
> 65% freddo	C	A	D	A	A1
≤ 65% caldo	D	A	D	C	A1

O-rings resistance to fluids

	NBR	FKM	MQV	EPDM	FFKM
A					
Acetaldehyde	C	D	B	B	A1
Acetamide	A	C	B	A	A1
Acetate of copper	B	D	D	A	A
Acetic acid concentrated (glacial acetic acid)	B	D	B	B	A
hot	D	D	C	C	A
Acetic anhydride	D	D	B	B	A
Acetoacetic ester	D	D	B	B	A
Acetone	D	D	D	A	A
Acetophenone	D	D	D	A	A
Acetyl chloride	D	A	C	D	A
Acetylacetone	D	D	D	A	A
Acetylene, Ethene	A	A	B	A	A
Acrylic acid ethyl ester	D	D	B	B	A1
Acrylonitrile	D	C	D	D	A1
Aero Shell 7A	A	A	B	D	A
Aero Shell 17	A	A	B	D	A
Aero Shell 750	B	A	D	D	A
Aero Shell Fluid 4	A	A	D	D	A
Aerosafe 2300	D	D	C	A	-
Aerosafe 2300 W	D	D	C	A	-
Air	A	A	A	A	A
Air oil-free					
100°C	A	A	A	A	A
150°C	B	A	A	B	A
200°C	D	A	A	D	A
Alkazene®	D	B	D	D	A
Aluminium acetate	B	D	D	A	A
Aluminium bromide	A	A	A	A	A
Aluminium chloride	A	A	B	A	A
Aluminium fluoride	A	A	B	A	A
Aluminium nitrate	A	A	B	A	A
Aluminium phosphate	A	A	A	A	A
Aluminium sulphate	A	A	A	A	A
Alums	A	A	B	A	A
Ammonia gas					
(cold)	A	D	A	A	A1
gas (hot)	D	D	B	A	A1
liquid (anhydrous)	B	D	B	A	A1
Ammonium carbonate	C	B	D	A	A
Ammonium Chloride	A	A	B	A	A
Ammonium Chloride 3 molar solution	A	B	A	A	A
Ammonium hydroxide concentrated	D	C	A	A	A1
Ammonium nitrate	A	B	B	A	A
Ammonium nitrite	A	-	B	A	A
Ammonium persulphate	D	-	-	A	A
Ammonium persulphate solution	D	-	-	A	A
Ammonium phosphate	D	-	-	A	A
Ammonium phosphate					
primary	A	B	B	A	A
secondary	A	B	B	A	A
tertiary	A	B	B	A	A

	NBR	FKM	MQV	EPDM	FFKM
> 65% caldo	D	C	D	D	B
Acido fluoridrico (anidro)	D	D	D	A	B
Acido fluorosilicico	B	A	D	A	B
Acido fosforico - 3 molare	D	A	B	A	A
Acido fosforico - concentrato	D	A	C	B	A
Acido fumarico	A	B	D	D	A
Acido gallico	B	A	A	B	A
Acido lattico	A	A	B	A	A
	freddo	A	A	B	A
	caldo	D	A	B	D
Acido linoleico	B	B	B	D	A
Acido maleico	D	A	D	D	A
Acido maleico anidro	D	D	-	B	A
Acido malico	A	A	B	B	A
acido metacrilico	D	C	D	B	A
Acido muriatico, candeggina, varechina	D	A	B	A	B
Acido naftico	B	A	D	D	A
Acido Nevile-Wintchersche	D	A	D	B	A
Acido nitrico	D	A	D	B	A
	3 molare	D	A	D	B
	concentrato	D	A	D	D
	rosso, fumante	D	B	D	D
Acido oleico	C	B	D	D	A
Acido ossalico	B	A	B	A	A
Acido palmitico	A	A	D	B	A
Acido perclorico 2 molare	D	A	D	B	A
Acido picrinico sol. acquosa	A	A	D	A	A
Acido pirolegnoso	D	D	-	B	A
Acido prussico	B	A	C	A	A
Acido salicilico	B	A	A	A	A
Acido solfidrico					
secco, freddo	A	D	C	A	A
secco, caldo	D	D	C	A	A
umido, freddo	D	D	C	A	A
umido, caldo	D	D	C	A	A
Acido solforico 3 molare	D	A	D	B	A
Acido solforico concentrato	D	A	D	D	A
Acido solforico fumante (20/25%)	D	A	D	D	A
Acido solforico fumante	D	A	D	D	A
Acido solforoso	B	A	D	B	A
Acido stearico	B	A	B	B	A
Acido tannico	A	A	B	A	A
Acido tannico 105	A	A	B	A	A
Acido tartarico	A	A	A	B	A
Acqua bromica	D	A	D	D	A
Acqua di mare salata con cloro	D	A	D	D	A
Acqua di mare, acqua salata	A	A	A	A	A
Acqua ossigenata 90%	D	A	B	C	A
Acqua ossigenata diluita	B	A	A	A	A
Acqua pesante	A	A	A	A	A
Acqua ragia	A	A	D	D	A
Acqua regia	D	B	D	C	A1
Acqua fino a 70°C (per uso industriale)	A	B	A	A	A
Acqua fino a 100°C	B	B	B	A	A
Acque reflue	A	A	A	A	A
Acrilato di butile	D	D	D	D	A1
Acrilato di metile	D	D	D	B	A

	NBR	FKM	MQV	EPDM	FFKM
Ammonium sulphate	A	C	A	A	A
Ammonium sulphide	A	D	B	A	A
Amyl acetate	A	D	B	A	A
Amyl alcohol	D	D	D	A	A
Amyl borate	B	B	D	A	A
Amyl chloride	A	A	-	D	A
Amyl chloronaphtalene	D	A	D	D	A
Amyl naphtalene	D	A	D	D	A
Aniline (aniline oil)	D	A	D	D	A
Aniline dyes	D	C	D	B	A
Aniline hydrochloride	D	B	C	B	A
Animal fat	A	A	B	B	A
Aqua regia	D	B	D	C	A1
Argon	B	B	C	B	A
Aromatic fuels (fuel C) 50%	A	A	A	A	A
Arsenic acid (arsenic trichloride)	A	D	D	D	A
Asphalt	A	A	A	A	A
ASTM-oil No°.1	B	A	D	D	A
ASTM-oil No°.2	A	A	A	D	A
ASTM-oil No°.3	A	A	D	D	A
ASTM-oil No°.4	A	A	C	D	A
ASTM-reference	fuel A	B	A	D	D
	fuel B	A	A	D	D
	fuel C	A	A	D	D
ATF-oil	B	A	D	D	A
B					
Barium chloride	A	A	A	A	A
Barium hydroxide	A	A	A	A	A
Barium sulphide	A	A	A	A	A
Beer	A	A	A	A	A
Benzaldehyde	D	D	D	A	A
Benzene	D	A	D	D	A
Benzene-sulphonic acid 10%	D	A	D	D	A
Benzonic	acid	D	A	D	B
	benzyl ester	D	A	-	D
	methyl ester	D	A	D	D
Benzophenone	-	A	-	B	A
Benzoyl chloride	D	A	-	A	A
Benzyl alcohol	D	A	B	B	A
Benzyl chloride	D	A	D	D	A
Black liquor	B	A	B	B	-
Blast furnace gas	D	A	A	D	A
Beaching lye	D	A	B	A	A
Borax	B	A	B	A	A
Bordeaux mixture	B	A	B	A	A
Boric acid	A	A	A	A	A
Boron liquid (HEF)	B	A	D	D	-
Bromine	D	A	D	D	A
Bromine water	D	A	D	D	A
Bromobenzol	D	A	D	D	B
Bromochloromethane	D	A	D	B	A
Bromochlorotrifluoroethan	D	A	D	D	A
Bromopentafluoride	D	D	D	D	B
Bromotrifluoride	D	D	D	D	B

		NBR	FKM	MQV	EPDM	FFKM
Acrilnitrile		D	C	D	D	A1
Aero Shell	17	A	A	B	D	A
	7A	A	A	B	D	A
	750	B	A	D	D	A
	Fluid 4	A	A	D	D	A
Aerosafe	2300	D	D	C	A	–
Aerosafe	2300W	D	B	D	D	A
Alcazene®		B	B	D	A	A
Alcool amilico		D	A	B	B	A
Alcool benzilico		A	A	B	B	A
Alcool butilico		A	A	A	A	A
Alcool denaturato		D	D	D	A	A
Alcool diacetico (Diacetone)		A	A	B	C	A
Alcool esilico		A	C	A	A	A
Alcool etilico (etanolo)		D	D	D	B	A
Alcool furfurlico		B	A	A	A	A
Alcool isobutilico (isobutanolo)		B	A	A	A	A
Alcool isopropilico (isopropanolo)		A	D	A	A	A
Alcool metilico		A	D	A	A	A
Alcool metilico (metanolo)		B	A	B	A	A
Alcool ottilico		B	A	B	A	A
Alcool propilico (propanolo)		A	A	A	A	
Aldeide capronica		–	D	B	B	A1
Allume		A	A	B	A	A
Allume al cromo		A	A	A	A	A
Ammoniaca						
gassosa (fredda)		A	D	A	A	A1
gassosa (calda)		D	D	B	B	A1
liquida (anidra)		B	D	B	A	A1
Anidride acetica		D	D	B	B	A
Anidride carbonica		A	A	A	A	A
Anidride solforosa						
umida		D	D	B	A	A
secca		D	D	B	A	A
liquida sotto pressione		D	D	B	A	A
Anilina (olio d'anilina)		D	C	D	B	A
Antigelo Prestune		A	A	A	A	A
Argon		A	A	A	A	A
Aria		A	A	A	A	A
Aria compressa (senza olio)		A	A	A	A	A
Aria, senza olio	100°C	A	A	A	A	A
	150°C	B	A	A	B	A
	200°C	D	A	A	D	A
Asfalto		B	A	D	D	A
Azoto		A	A	A	A	A

B

Bagni galvanici	cromo	D	A	B	B	A
	altri metalli	–	A	D	A	A
Bagno sviluppatore (foto)		A	A	A	B	A
Benzaldeide		D	D	D	A	A
Benzene isopropilico		D	A	D	D	A
Benzilestere di acido benzoico		D	A	–	D	A
Benzina		A	A	D	D	A
Benzina super		A	A	D	D	A

		NBR	FKM	MQV	EPDM	FFKM
Butadine (monomer)		D	A	D	D	A
Butan-2-one (methyl ethyl ketone, MEK)		D	D	D	A	A
Butane		A	A	D	D	A
Butanol (butyl alcohol)		A	A	B	B	A
Butene		B	A	D	D	A
Butter		A	A	B	A	A
Butyl	acetate	D	D	D	B	A
	acetyricinoleate	B	A	–	A	B
	acrylate	D	D	D	D	A1
	alcohol	A	A	B	B	A
	butyrate	D	A	–	A	A
	carbitol	D	C	D	A	A
	catechol	D	A	–	B	A
	cellosolve	D	D	D	B	A
	glycol	C	D	B	B	A
	glycoladipate	D	B	B	B	A
	mercaptan	D	A	D	D	A
	oleate	D	A	–	D	A
	stearate	B	A	B	D	A
Butylo n-Butyl ether		C	D	D	C	A
Butylamine, n-Butylamine		C	D	B	D	A1
Butyraldehyde		D	D	D	B	A1
Butyric acid		D	B	D	B	A

C

Calcium	acetate	B	D	D	A	A
	bisulphite	A	A	A	D	A
	chloride	A	A	A	A	A
	cyanide	A	–	A	A	A
	hydroxide	A	A	B	A	A
	hypochloride	B	A	B	A	A
	lysulphide	A	A	A	A	A
	nitrate (nitrate of lime)	A	A	B	A	A
	silicate	A	A	–	A	A
	sulphite	A	A	A	A	A
	thiosulphate	B	A	A	A	A
Caliche solution (chile salt/pepre)		A	A	B	A	A
Caproic aldehyde (Hexanal)		–	D	B	B	A1
Carbamates		D	A	–	B	A
Carbitol/Diethylene						
glycol monoethyl ether		B	B	B	B	A
Carbolic acid (phenol)		D	A	D	D	A
Carbon dioxide	dry	A	B	B	B	A
	moist	A	B	B	B	A
Carbon	disulphide	D	A	D	D	A
	monoxide	A	A	A	A	A
Carbon tetrachloride		B	A	D	D	B
Carbonic acid		B	A	A	A	A
Castor oil		A	A	A	B	A
Cellosolve (Ethylene glycol ethyl ether)		D	D	D	B	A
Cellosolve acetate		D	D	D	B	A
Cetane (Hexadecane)		A	A	D	D	A
Chloroacetone		D	D	D	A	A
Chlorax		B	A	–	B	A
Chlordane		B	A	D	D	A

	NBR	FKM	MQV	EPDM	FFKM
Benzoato d'etile	D	A	D	D	A
Benzoato di n-butile	D	A	-	D	A
Benzofenene	-	A	-	B	A
Benzolo	D	A	D	D	A
Benzolo bromico	D	A	D	D	B
Bibromuro d'etilene	D	A	D	C	A
Bicloruro d'etilene	D	A	D	C	A
Bicromato di potassio	A	A	A	A	A
Birra	A	A	A	A	A
Bisolfato di sodio	A	A	A	A	A
Bisolfuro di calcio	A	A	A	D	A
Borace	B	A	B	A	B
Borato d'amile	A	A	-	D	A
Borato di sodio (Borace)	A	A	A	A	A
Brenzcatechina di butile	D	A	-	B	A
Bromo	D	A	D	D	A
Bromoclorometano	D	A	D	B	A
Bromuro d'alluminio	A	A	A	A	A
Bromuro d'etile	B	A	D	D	A
Bromuro di metile	B	A	D	D	A
Burro	A	A	B	A	A
Butadiene (monomero)	D	A	D	D	A
Butano	A	A	D	D	A
Butanolo (alcol butilico)	A	A	B	B	A
Butanone (metiletilchetone, MEK)	D	D	D	A	A
Butilaldeide	D	D	D	B	A1
Butilamina, n- butilamina	C	D	B	D	A1
Butilcarbitalo	D	C	D	A	A
Butilene	B	A	D	D	A
Butilestere di acido butirrico	D	A	-	A	A
Butilglicolapitato	D	B	B	B	A
Butilglicole	C	D	B	B	A
Butirato-n-isobutilico	D	A	-	A	A
C					
Caffè	A	A	A	A	A
Carbomate	D	A	-	B	A
Carbitol/Etere monoetilico di dietilenglicole	B	B	B	B	A
Carbonato d'ammonio	C	B	D	A	A
Carbonato di metile	D	A	D	D	A
Carbonato di sodio (soda)	A	A	A	A	A
Carburante di riferimento					
ASTM	A	A	D	D	A
B	A	A	D	D	A
C	B	A	D	D	A
Carburante diesel	A	A	D	D	A
Catrame (bituminoso)	B	A	B	D	A
Cellosolve (etere etilico di etilenglicole)	D	D	B	D	A
Cellosolve butilico	D	D	D	B	A
Cellulosa d'etile	B	D	B	B	A
Cellulosa metilica	B	D	D	D	A
Chetano (ecadecano)	A	A	D	D	A
Cianorato di potassio	A	A	A	A	A
Cianuro di calcio	A	-	A	A	A

	NBR	FKM	MQV	EPDM	FFKM
Chlordecane	D	A	D	D	A
Chloracetic acid	D	D	D	B	A
Chlorextol	B	A	D	D	A
Chlorinated carbonic acid ethyl ester	D	A	D	D	A
Chlorine dioxide	D	A	D	C	A
8% Cl as CaClO in solution	D	A	D	D	A
Chlorine					
dry	D	B	D	D	A
moist	C	A	-	B	B
naphthaline	D	A	D	D	A
trifluoride	D	D	D	D	B
1-chlorine-nitroethane	D	D	D	D	A
Chloroacetic acid	D	A	D	D	A
Chlorobenzene (monochlorobenzene)	D	A	D	D	A
Chloroform (Trichloromethane)	D	A	D	D	A
Chloroprene	D	A	D	D	A
Chlorosulphonic acid	D	D	D	D	A
Chlortoluene	D	A	D	D	A
Chrome bath electrolyte	D	A	B	B	A
Chrome alum	A	A	A	A	A
Citric acid	A	A	A	A	A
Cobalt chloride	A	A	B	A	A
2n	A	A	A	A	A
Coconut oil	A	A	A	C	A
Cod liver oil	A	A	B	A	A
Coffee	A	A	A	A	A
Colamine (ethanolamine)	D	D	B	B	A1
Coliche-solution	B	-	-	B	-
Compressed air supply (oil-free)	A	A	A	A	A
Coolanol (Monsanto), Silicone oil	A	A	D	D	A
Copper chloride	A	A	A	A	A
Copper cyanide	A	A	A	A	A
Cotton seed oil	A	A	A	C	A
Creosote, carbolineum	A	A	D	D	A
Cresilic acid	D	A	D	D	-
Crude oil	B	A	D	D	A
Crumene (isopropylbenzene)	D	A	D	D	A
Cyclohexane	A	A	D	D	A
Cyclohexanol	A	A	D	D	A
Cyclohexanon	D	D	D	B	A
D					
Decane	A	A	B	D	A
Delco brake fluid	C	D	C	A	A
Denaturated alcohol	A	A	A	A	A
Detergent dissolved in water	A	A	A	A	A
Developer (photo)	A	A	A	B	A
Diacetone alcohol	D	D	D	A	A
Diazinone (insecticide)	C	B	D	D	-
Dibenzyl					
ether	D	D	D	B	A
sebacate	D	B	C	B	A
Dibromethyl benzol	D	A	D	D	A
Dibromodifluoromethane	D	-	D	B	B
Dibutyl					
amine	D	D	C	D	A1
ether	D	C	D	C	A
phthatale	D	C	C	B	A

+ TECH TECHNICAL SHEETS

www.gemels.it

	NBR	FKM	MQV	EPDM	FFKM
Detersivo disciolto in acqua	A	A	A	A	A
Diamina d'etilene	A	D	A	A	A1
Diazinone (insetticida)	C	B	D	D	-
Dibromdifluorometano	D	-	D	B	B
Dibrometilbenzolo	D	A	D	D	A
Dibutilamina	D	D	C	D	A1
Dicicloesilamina	C	D	D	D	A1
Diclorometano (cloruro di tetrametilene)	B	A	D	D	A
Dicolorometano (cloruro di metilene)	D	B	D	D	A
Detilamina	B	D	B	B	A1
Dietilenglicole	A	A	B	A	A
Difenile (Bifenile)	D	A	D	D	A
Diisobutilene	B	A	D	D	A
Diisonianato di toluilene	D	D	D	B	A
Diisopropilchetone	D	D	A	D	A
Diluente per vernici	D	B	D	D	A
2,2 Dimetilbutano	A	A	D	D	A
2,4 Dimetilbutano	A	A	D	D	A
2,4 Dimetilpentano	A	A	D	D	A
Dimetilformamide (DMF)	C	D	B	B	A
Dimetilidrazina	B	D	D	A	A
Dinitrotoluene	D	D	D	D	A
Diossano	D	D	D	B	A
Diossido di cloro	D	A	D	C	A
Diossido di cloro 8% Cl come Ca ClO in soluzione	D	A	D	D	A
Diossolano	D	D	D	B	A
Dipenten (Solvente per vernici)	B	A	D	D	A
Dowtherm A	D	A	D	D	A
Dowtherm E	D	A	D	D	A

E

Elettroliti per bagni di cromo	D	A	B	B	A
Elio	A	A	A	A	A
Emulsione di acetato di polivinile	-	-	-	A	A
Epicloridrina	D	D	D	B	A
n-eptano	A	A	D	D	A
Esaffluoruro di zolfo (SF6)	B	C	B	A	B
n-esaldeide	D	D	B	A	A1
n-esano	A	A	D	D	A
1-n-esene	B	A	D	D	A
Etere acetacetico	D	D	B	B	A
Etere di acido etilacrilico	D	D	B	B	A1
Etere di silicato	B	A	D	D	A
Etere etilico di acido cloracetico	D	A	D	D	A
Etere etilico di cloruro di carbonio	D	A	D	D	A
Etere metilico di acido formico	D	D	-	B	A
Etano	A	A	D	D	A
Etanolamina (Colamina)	B	D	B	B	A1
Etanolo (alcool etilico)	A	C	A	A	A
Etere dibenzilico	D	D	D	B	A
Etere dibutilico	D	C	D	C	A
Etere dicloroisopropilico	D	C	D	C	A
Etere dietilico	D	D	D	D	A
Etere difenilico	D	A	C	D	A

	NBR	FKM	MQV	EPDM	FFKM
dichloride	D	B	D	D	A
ether	C	D	D	C	A
oxalate	D	A	D	A	A
pentachlorobenzene	D	A	D	D	A
silicate	A	A	B	A	A
Ethylbenzene	D	A	D	A	A
Ethylcellulose	B	D	B	B	A
Ethylene					
chlorhydrin	D	A	C	B	A
dibromide	D	A	D	C	A
dichloride	D	A	D	C	A
glycol (glycol)	A	A	A	A	A
oxide	D	D	D	C	A1
oxide (12%) and Freon (80%)	C	D	D	B	A1
trichloride ("Tri")	D	A	D	D	A
2-ethyl-1-hexanol (Isocetanol)	A	A	B	A	A
Ethylendiamine	A	D	A	A	A1

F

	NBR	FPM	MQV	EPDM	FFKM
Fatty acids	B	A	B	C	A
Fluorolub	A	B	A	A	-
Formaldehyde	C	D	B	B	A1
Formic acid methylester	D	D	-	B	A
Freon					
11	B	B	D	D	B
12	A	A	D	B	B
12 and ASTM oil no. 2 (50:50 mix)	B	A	D	D	B
12 and Suniso 4g (50:50 mix)	B	A	D	D	B
13	A	A	D	A	B
13B1	A	A	D	A	B
14	A	A	D	A	B
21	D	D	D	D	A
22	D	D	D	A	B
22 and ASTM oil no. 2 (50:50 mix)	D	B	D	D	B
31	D	D	D	A	B
32	A	D	D	A	B
112	B	A	D	D	B
113	A	B	D	D	B
114	A	A	D	A	B
114 B2	B	B	D	D	B
115	A	A	D	A	B
502	B	B	A	A	B
BF	B	A	D	D	B
C 318	A	B	D	A	B
K-142b	A	D	-	A	B
K-152a	A	D	-	A	B
MF	B	B	D	D	B
PCA	A	B	D	D	B
TF	A	B	D	D	A
Fuel oil	A	A	D	D	A
Fumaric acid	A	B	D	D	A
Fural (2-furaldehyde)	D	D	D	B	A1
Furan	D	D	D	D	A
Furfur alcohol	D	D	D	B	A
Furyl carbinol	D	-	D	B	-

	NBR	FKM	MQV	EPDM	FFKM
Etere dimetilico (Etere metilico)	A	A	A	A	A
Etere feniletilico	D	D	D	D	A
Etere isopropilico	B	D	D	D	A
Etere metilico (Dimetiletere)	A	A	A	A	A
Etere n-butilico	C	D	D	C	A
Etere etilico	C	D	D	C	A
Eteri (diversi)	D	C	D	C	A
2-etil-1-esanolo (Isotanololo)	A	A	B	A	A
Etilbenzolo	D	A	D	A	A
Etilene glicol (glicole)	A	A	A	A	A
Etilmercaptano	D	B	C	D	A

F

Fenilideazina	D	A	D	D	A
Fenolo	D	A	D	D	A
Fluido per trasmissioni tipo A	A	A	B	D	A
Fluorolub	A	B	A	A	-
Fluoruro d'alluminio	A	A	B	A	A
Formaldeide	C	D	B	B	A1
Foron	D	D	D	A	A
Fosfato d'alluminio	A	A	A	A	A
Fosfato d'ammonio primario	A	B	B	A	A
secondario	A	B	B	A	A
terziario	A	B	B	A	A
Fosfato di calcio	A	A	A	A	A
Fosfato di sodio primario	A	A	D	A	A
Fosfato di sodio secondario	A	A	D	A	A
Fosfato di sodio terziario	A	A	A	A	A
Fosfato di triclesile ("TCP")	D	B	C	A	A
Fosfato di triarile	D	A	C	A	A
Fosfato tributile	D	D	D	A	A
Fosfato tributossietile	D	A	-	A	A
Fosfato triottile	D	B	C	A	A
Freon					
11	B	B	D	D	B
12	A	A	D	B	B
12 ed olio ASTM N°2 (miscela 50:50)	B	A	D	D	B
12 e Suniso 4 G (miscela 50:50)	B	A	D	D	B
13	A	A	D	A	B
13 B1	A	A	D	A	B
14	A	A	D	A	B
21	D	D	D	D	A
22	D	D	D	A	B
22 ed olio ASTM N° 2 (miscela 50:50)	D	B	D	D	B
31	D	D	D	A	B
32	A	D	D	A	B
112	B	A	D	D	B
113	A	B	D	D	B
114	A	A	D	A	B
114 B2	B	B	D	D	B
115	A	A	D	A	B
502	B	B	A	A	B
BF	B	A	D	D	B

	NBR	FKM	MQV	EPDM	FFKM
G					
Galic acid	B	A	A	B	A
Gallotannic acid	tannin	A	A	B	A
	10%	A	A	B	A
Gear oil type A	A	A	B	D	A
Gelatines	A	A	A	A	A
Generator gas	A	A	B	D	A
Girling brake fluid	C	D	-	A	A
Glacial acetic acid (100% acetic acid)	B	D	B	B	A
Glauber salt (sodium sulphate)	D	A	A	B	A
Glucose	A	A	A	A	A
Glycerine	A	A	A	A	A
	triacetate	B	D	B	A
Glycol (ethylene glycol)	A	A	A	A	A
Green liquor	B	A	-	A	A
Groundnut oil	A	A	A	C	A

H

Halon 1301	A	A	D	A	B
Halothane (narcotic)	D	A	D	D	A
Halowax oil	D	A	D	D	A
Heavy water	A	A	A	A	A
Helium	A	A	A	A	A
n-heptane	A	A	D	D	A
n-hexaldehyde	D	D	B	A	A1
n-hexane	A	A	D	D	A
1-n-hexene	B	A	D	D	A
Hexylalcohol	A	A	B	C	A
Houghto-Safe					
241 (water/glycol, HCF)	A	B	B	A	A
620 (water/glycol, HCF)	A	B	B	A	A
1010 (phosphate ester, HFD-R)	D	A	C	A	A
1055 (phosphate ester, HFD-R)	D	A	C	A	A
1120 (phosphate ester, HFD-R)	D	A	C	A	A
5040 (water/oil emulsion)	A	A	C	D	A
Hydraulic fluid (mineral oil based)	A	A	B	D	A
Hydrazine	B	B	B	A	A
Hydrobromic acid	D	A	D	A	A
Hydrobromic acid 40%	D	A	D	A	A
Hydrochloric acid 3-molar	C	A	D	A	A
	concentrated	D	A	D	C
Hydrocyanic acid	B	A	C	A	A
	≤65% cold	C	A	D	A
	> 65% cold	D	A	D	C
	≤65% hot	D	C	D	D
	>65% hot	D	C	D	D
Hydrofluosilicic acid	B	A	D	A	B
Hydrogen fluoride (hydrofluoric acid, anhydrous)	D	D	D	A	B
Hydrogen gas					
cold	A	A	C	A	A
hot	A	A	C	A	A
Hydrogen peroxide					
90%	D	A	B	C	A
dilute	B	A	A	A	A
Hydrogen sulphide					
dry, cold	A	D	C	A	A
dry, hot	D	D	C	A	A
moist, cold	D	D	C	A	A
moist, hot	D	D	C	A	A

	NBR	FKM	MQV	EPDM	FFKM
C 318	A	B	D	A	B
K-152a	A	D	-	A	B
K-142b	A	D	-		B
MF	B	B	D	D	B
PCA	A	B	D	D	B
TF	A	B	D	D	A
Flatato di dibutile (Palatinol C)	D	C	C	B	A
Flatato di dimetile	D	B	-	B	A
Flatato di diottille (DOP)	D	B	C	B	A
Furano	D	D	D	D	A
Furfurolo (Furaldeide)	D	D	D	B	A1
Fluricarbinol	D	-	D	B	-
Fuso	B	A	D	B	B

G					
Gas d'altoforno	D	A	A	D	A
Gas di città	A	A	B	D	A
Gas liquido (propano, butano, propilene)	A	A	C	D	A
Gas naturale	A	A	A	D	A
Gelatina	A	A	A	A	A
Glicerina	A	A	A	A	A
Glicole (Etilenglicole)	A	A	A	A	A
Glucosio	A	A	A	A	A
Grassi al silicone	A	A	D	A	A
Green liquor	B	A	-	A	A

H					
Halon 1301	A	A	D	A	B
Halothan (narcotico)	D	A	D	D	A
Houghto-Safe					
241 (Acqua/glicole,HCF)	A	B	B	A	A
620 (Acqua/glicole,HCF)	A	B	B	A	A
1010 (estere fosfato, HDF-R)	D	A	C	A	A
1055 (estere fosfato, HDF-R)	D	A	C	A	A
1120 (estere fosfato, HDF-R)	D	A	C	A	A
5040 (emulsione acqua/olio)	A	A	C	D	A

I					
Idina	B	D	D	A	A
Idrato di bromo	D	A	D	A	A
Idrato di bromo 40%	D	A	D	A	A
Idrazina	B	B	B	A	A
Idrochinone	C	B	D	D	A
Idrossido d'ammonio					
soluzione 3 molare	A	B	A	A	A
concentrato	D	C	A	A	A1
Idrossido di bario	A	A	A	A	A
Idrossido di calcio	A	A	B	A	A
Idrossido di magnesio	B	A	A	A	A
Idrossido di potassio,					
potassa caustica 50%	B	D	C	A	A
Idrossido di sodio 3 molare	B	B	A	A	A
Iodio	B	A	-	B	A
Ipoclorito di sodio	C	A	C	C	A
Ipocloruro di calcio	B	A	B	A	A

	NBR	FKM	MQV	EPDM	FFKM
Hydroquinone	C	B	D	D	A
Hydyn	B	D	D	A	A

I					
Iodine	B	A	-	B	A
Iodine pentafluoride	D	D	D	D	B
Iron chloride	A	A	B	A	A
Iron nitrate	A	A	B	A	A
Isobutyl alcohol (isobutanol)	B	A	A	A	A
Isobutyl-n-butyrate	D	A	-	A	A
Isododecane	A	A	D	D	A
Iso-octane	A	A	D	D	A
Isophoron (Ketone)	D	D	D	A	A
Isopropanol (isopropyl alcohol)	B	A	A	A	A
Isopropyl					
benzene	D	A	D	D	A
chloride	D	A	D	D	A
Isopropylacetate	D	D	D	B	A
Isopropylacetate	B	D	D	D	A
Isopropylalkohol (isopropanol)	B	A	A	A	A

J					
JP 3 (MIL-J-5624)	A	A	D	D	A
JP 4 (MIL-J-5624)	A	A	D	D	A
JP 5 (MIL-J-5624)	A	A	D	D	A
JP 6 (MIL-J-5624)	A	A	D	D	A
JP X (MIL-F-2564)	A	D	D	D	-

K					
Kaliumcyanide	A	A	A	A	A
Kerosene	A	D	D	D	-

L					
Lactams	D	D	-	B	A
Lactic acid					
cold	A	A	B	A	A
hot	D	A	B	D	A
Lard, animal fat	A	A	B	B	A
Lavender oil	B	A	D	D	A
Lead					
acetate (sugar of lead)	B	D	D	A	B
nitrate	A	A	B	A	B
sulphate	B	A	B	A	A
Light crude oil (crude benzene)	A	A	D	D	A
Light lubricants	A	A	D	D	A
Lime milk	A	A	B	A	A
Linoleic acid	B	B	B	D	A
Linseed oil	A	A	A	C	A
Liquid gas (Propane, Butane, Propylene)	A	A	C	D	A
Liquimoly	A	A	D	D	A
Lubricating oils					
di-ester based	B	A	D	D	A
petroleum based	A	A	D	D	A
SAE 10, 20, 30, 40, 50	A	A	C	D	A

M					
Magnesium					
Chloride	A	A	A	A	A
hydroxide	B	A	A	A	A

	NBR	FKM	MQV	EPDM	FFKM
Isododecano	A	A	D	D	A
Isoforene (chetone)	D	D	D	A	A
Isopropanolo (alcool isopropilico)	B	A	A	A	A
Isottano	A	A	D	D	A

J	NBR	FPM	MQV	EPDM	FFKM
JP 3(MIL-J-5624)	A	A	D	D	A
JP 4(MIL-J-5624)	A	A	D	D	A
JP 5(MIL-J-5624)	A	A	D	D	A
JP 6(MIL-J-5624)	A	A	D	D	A
JP X(MIL-J-25604)	A	D	D	D	-

K	NBR	FKM	MQV	EPDM	FFKM
Kerosene	A	A	D	D	A

L	NBR	FKM	MQV	EPDM	FFKM
Lattame	D	D	-	B	A
Latte	A	A	A	A	A
Latte di calce	A	A	B	A	A
Liquido di Boron (HEF)	B	A	D	D	-
Liquido per freni Delco	C	D	C	A	A
Liquido per freni Girling	C	D	-	A	A
Mopar	C	D	C	A	A
su base senza olio minerale	C	D	C	A	A
Liquimoly	A	A	D	D	A
Lisciva nera	B	A	B	B	-
Lubrificante leggero	A	A	D	D	A

M	NBR	FKM	MQV	EPDM	FFKM
Malathion (insetticida)	B	A	D	D	A
Mercaptano di butile	D	A	D	D	A
Mercaptano di tributile	D	A	D	D	A
Mercurio	A	A	A	A	A
Metacrilato di metile	D	D	D	D	A1
Metafosfato di sodio (Calgon)	A	A	-	A	A
Metano	A	A	D	D	A
Metasilicato di sodio	A	A	-	A	A
Metilanilina	D	B	-	D	A
Metilbutichetone	D	D	D	A	A
Metilestere di acido benzoico	D	A	D	D	A
Metililchetone (Butanone,MEK)	D	D	D	A	A
Metilglicole	C	D	D	B	A
Metilsobutilchetone	D	D	D	C	A
2-Metilpentano	D	D	D	B	A
3-Metilpentano	A	A	D	D	A
Miscela d'ammine	A	A	D	D	A
Miscela di rame e calcio	D	D	B	B	A1
Monoclorobenzene (Clorobenzolo)	B	A	B	A	A
Monossido d'azoto (gas esilirante)	D	A	D	D	A
	A	A	A	B	A

N	NBR	FKM	MQV	EPDM	FFKM
Nafta	B	A	D	D	A
Naftalina	D	A	D	D	A
clorica	D	A	D	D	A
d'amile	D	A	D	D	A

	NBR	FKM	MQV	EPDM	FFKM
sulphate	A	A	A	A	A
Maize oil	A	A	A	C	A
Malathion (insecticide)	B	A	D	D	A
Maleic acid	D	A	D	D	A
anhydrous	D	D	-	B	A
Malic acid	A	A	D	D	A
Mercury	A	A	A	A	A
Mercury chloride	A	A	A	A	A
vapour	A	A	A	A	A
Mesityl oxide (ketone)	D	D	D	B	A
Methacrylic acid	D	C	D	B	A
Methane	A	A	D	D	A
Methyl 2-Methyl pentane	A	A	D	D	A
3-Methyl pentane	A	A	D	D	A
acetate	D	D	D	B	A
Methyl aceto acetate	D	D	B	B	A
alcohol (methanol)	A	D	A	A	A
bromide	B	A	D	D	A
butyl ketone	D	D	D	A	A
carbonte	D	A	D	D	A
cellulose	B	D	B	B	A
chloride	D	A	D	C	A
Chloroform	D	A	D	D	A
ether (dimethyl ether)	A	A	A	A	A
ethyl ketone (butanon, MEK)	D	D	D	A	A
ethyl ketone peroxide	D	D	B	D	A1
glycol	C	D	D	B	A
isobutyl ketone (MIBK)	D	D	D	C	A
methacrylate	D	D	D	D	A1
oleate	D	A	-	B	A
Methylaniline	D	B	-	D	A
Methylcyclopentane	D	A	D	D	A
Methylene chloride (dichloromethane)	D	B	D	D	A
Methylisopropylketone	D	D	D	B	A
Metilacrilato	D	D	D	B	A
Milk	A	A	A	A	A
Mineral oils	A	A	B	D	A
Mixed amines	D	D	B	B	A1
Molten sulphur	D	A	C	C	A
Monoclorobenzene (chlorobenzene)	D	A	D	D	A
Mopar brake fluid	C	D	C	A	A

N	NBR	FKM	MQV	EPDM	FFKM
Naphtha	B	A	D	D	A
Naphthaline	D	A	D	D	A
Naphthenic acid	B	A	D	D	A
Natural gas	A	A	A	D	A
n-Butyl benzoate	D	A	-	A	A
Neat's foot oil	A	A	B	B	A
Neon	A	A	A	A	A
Neville and Winther's acid	D	A	D	B	A
Nickel acetate	B	D	D	A	A
chloride	A	A	A	A	A
sulphate	A	A	A	A	A

"The company reserves the right to operate dimensional changes without prior notice".

+ TECH TECHNICAL SHEETS

www.gemels.it

	NBR	FKM	MQV	EPDM	FFKM
Neon	D	A	D	D	A
Nitrato d'alluminio	A	A	A	A	A
Nitrato d'ammonio	A	A	B	A	A
Nitrato d'argento	A	B	B	A	A
Nitrato di calcio	B	A	A	A	A
Nitrato di ferro	A	A	B	A	A
Nitrato di piombo	A	A	B	A	A
Nitrato di potassio	A	A	B	A	A
Nitrato di propile	A	A	A	A	A
Nitrato di sodio	D	D	D	B	A
Nitrito d'ammonio	B	A	D	A	A
Nitrobenzene	A	-	B	A	A
Nitroetano	D	B	D	D	A
Nitrometano	D	A	D	B	A
Nitropropano	D	A	D	B	A
Nitrotoluolo (miscela di 40%+dinitrotoluolo 60%)	D	A	D	B	A
	D	C	D	D	A

O

Oleato di butile	D	A	-	D	A	
Oleato di metile	D	A	-	B	A	
Oli di silicone	A	A	D	A	A	
Oli lubrificanti	a base di esteri	B	A	D	A	
	a base di petrolio	A	A	D	A	
	SAE 10, 20, 30, 40, 50	A	A	C	D	A
Oli minerali	A	A	B	D	A	
Oli vegetali	A	A	A	C	A	
Olio animale	A	A	B	B	A	
Olio ASTM	n°1	A	A	A	D	A
	n°2	A	A	D	D	A
	n°3	A	A	C	D	A
	n°4	B	A	D	D	A
Olio ATF	A	A	D	D	A	
Olio d'arachidi	A	A	A	C	A	
Olio d'oliva	A	A	A	B	A	
Olio di catrame (Carbolineum)	A	A	D	D	A	
Olio di cera alogena	D	A	D	D	A	
Olio di cocco	A	A	A	C	A	
Olio di colza	A	A	D	A	A	
Olio di cotone	A	A	A	C	A	
Olio di fegato di merluzzo	A	A	B	A	A	
Olio di lavanda	B	A	D	D	A	
Olio di lino	A	A	A	C	A	
Olio di mais	A	A	A	C	A	
Olio di piede di bue	A	A	B	B	A	
Olio di pino	A	A	D	D	A	
Olio di pino bianco	B	A	D	D	A	
Olio di piridina	D	D	D	B	A	
Olio di ricino	A	A	A	B	A	
Olio di soja	A	A	A	C	A	
Olio di terpenina	B	A	-	C	A	
Olio emulsionabile	A	A	D	D	A	
Olio idraulico (a base di olio minerale)	A	A	B	D	A	
Olio leggero (Benzene grezzo)	A	A	D	D	A	
Olio per ingranaggi tipo A	A	A	B	D	A	

	NBR	FKM	MQV	EPDM	FFKM
Nitrobenzene	D	B	D	D	A
Nitroethane	D	A	D	B	A
Nitrogen	A	A	A	A	A
Nitromethane	D	A	D	B	A
Nitropropane	D	A	D	B	A
Nitrotoluene (40% + dinitrotoluene 60% mix)	D	C	D	D	A
Non- mineral oil base brake fluid	C	D	C	A	A
n-propyl acetone	D	D	D	A	A

O

Octachlorotoluene	D	A	D	D	A
Octadecane	A	A	D	D	A
Octyl alcohol	B	A	B	A	A
Oleic acid	C	B	D	D	A
Oleum (fuming sulphuric acid)	D	A	D	D	A
Olive oil	A	A	A	B	A
Ortho-chloroethyl benzene	D	A	D	D	A
Orthochlorophenol	D	A	D	D	A
Ortho-dichlorobenzene	D	A	D	D	A
Ortho-n-octane	B	A	D	D	A
Oxalic acid	B	A	B	A	A
Oxygen, liquid	D	D	D	D	A1
Ozone	D	A	A	A	A1

P

Paint thinners	D	D	D	D	A	
Paints	B	A	D	D	A	
Palmitic acid	A	A	D	B	A	
n-pentane	A	A	D	D	A	
Perchloric acid 2-molar	D	A	D	B	A	
Petrol	A	A	D	D	A	
Phenol	D	A	D	D	A	
Phenyl ethyl ether	D	D	D	D	A	
Phenylhydrazine	D	A	D	D	A	
Phoron	D	D	D	A	A	
Phosphate of calcium	A	A	A	A	A	
Phosphoric acid, 3-molar aqueous solution	D	A	B	A	A	
Phosphoric acid, 3-molar concentrated molten	D	A	C	B	A	
Phosphoric acid, 3-molar Phosphorous chloride	D	A	D	A	A	
Picric acid aqueous solution	A	A	B	A	A	
Picric acid molten	B	A	D	B	B	
Pine oil	A	A	D	D	A	
Pinene	B	A	D	D	A	
Piperidine	D	D	D	D	A1	
Polyvinyl acetate emulsion	-	-	-	A	A	
Potassium	acetate	B	D	D	A	A
	chloride	A	A	A	A	A
	copper ferricyanide	A	A	A	A	A
	dichromate	A	A	A	A	A
	hydroxide solutions (dilute)	B	B	B	A	A
	hydroxide caustic potash 50%	B	D	C	A	A
	nitrate	A	A	A	A	A

	NBR	FKM	MQV	EPDM	FFKM
Olio per riscaldamento	A	A	D	D	A
Olio per trasformatori	A	A	B	D	A
Olio per turbine	A	A	D	D	A
Olio Tun (olio di legno della Cina)	A	A	D	D	A
Orto-cloroetilbenzolo	D	A	D	D	A
Ortoclorofenolo	D	A	D	D	A
Orto-diclorobenzolo	D	A	D	D	A
Orto-n-ottano	B	A	D	D	A
Ossalato d'etilene	D	A	D	A	A
Ossido d'etilene	D	D	D	C	A1
Ossidi d'etilene (12%) e Freon 12 (80%)	C	D	D	B	A1
Ossido di carbonio secco	A	B	B	B	A
Ossido di carbonio umido	A	B	B	B	A
Ossido mesitilico (Chetone)	D	D	D	B	A
Ossido propilico	D	D	D	B	A1
Ossigeno, gassoso freddo	A	A	C	A	A
Ossigeno, gassoso caldo	A	A	C	A	A
Ossigeno, liquido	D	D	D	D	A1
Ottacortoluolo	D	A	D	D	A
Ottadecano	A	A	D	D	A
Ozono	D	A	A	A	A1

P

Pentaclorobenzolo etile	D	A	D	D	A
Pentafluoruro di bromo	D	D	D	D	B
Pentafluoruro di iodio	D	D	D	D	B
n-Pentano	A	A	D	D	A
Perborato di sodio	B	A	B	A	A
Perossido di metiltilchetone	D	D	B	D	A1
Perossido di sodio	B	A	D	A	A
Persolfato d'ammonio	D	-	-	A	A
Petrolio	B	A	D	D	A
Pinene	B	A	D	D	A
Piombo tetraetile	B	A	D	D	A
Piperidina	D	D	D	D	A1
Pirrolio	D	D	B	D	A
Propano	A	A	D	D	A
Propellenti aromatici 50% (Fuel C)	A	D	D	D	A
Propilene	D	A	D	D	A
Propionitrile	A	A	D	D	A
Pyranol, olio per trasformatori (PCB)	A	A	D	D	A
Pyrolube	D	A	B	B	-

R

Radiazioni radioattive	C	D	C	C	-
Resine epossidiche	-	D	-	A	A
Ricinoleato di butilacetile	B	A	-	A	A

S

Sale si Glauber (Solfato di sodio)	-	D	A	A	A
Sale di Wolman (Impregnazione legno)	A	A	A	A	A
Sali d'ammonio	A	C	A	A	A
Sali di bario	A	A	A	A	A
Sali di Calcio	A	A	B	A	A
Sali di magnesio	A	A	A	A	A

	NBR	FKM	MQV	EPDM	FFKM
sulphate	A	A	A	A	A
sulphite	A	A	A	A	A
Prestune antifreeze	A	A	A	A	A
Propane	A	A	D	D	A
Propionitrile	A	A	D	D	A
Propyl acetate	D	D	D	B	A
Propyl alcohol (Propanol)	A	A	A	A	A
Propyl nitrate	D	D	D	B	A
Propylene	D	A	D	D	A
Propylene oxide	D	D	D	B	A1
Pyradine	D	D	D	B	A
Pyranol, transformer oil (postchlorinated biphenylene)	A	A	D	D	A
Pyrolube	D	A	B	B	-
Pyrrrole	D	D	B	D	A

R

Radioactive radiation	C	D	C	C	-
Rape oil	A	A	D	A	A

S

Salicylic acid	B	A	A	A	A
Salts of ammonium	A	B	B	A	A
barium	A	A	A	A	A
calcium	A	A	B	A	A
copper	A	A	A	A	A
magnesium	A	A	A	A	A
nickel	A	A	A	A	A
potassium	A	A	A	A	A
sodium	A	A	A	A	A
zinc	A	A	A	A	A
Seawater containing chlorine and salt	D	A	D	D	A
salt water	A	A	A	A	A
Silicate ester	B	A	D	D	A
Silicone greases	A	A	D	A	A
Silicone oil	A	A	D	A	A
Silver nitrate	B	A	A	A	A
Soda (sodium carbonate)	A	A	A	A	A
Soapy water	A	A	A	A	A
Sodium acetate	B	D	D	A	A
bicarbonate (baking soda)	A	A	A	A	A
bisulphate	A	A	A	A	A
borate (Borax)	A	A	A	A	A
carbonate (soda)	A	A	A	A	A
chloride	A	A	A	A	A
cyanide	A	A	A	A	A
hydroxide (caustic soda) 3 molar	B	B	A	A	A
hypochlorite	C	A	C	C	A
met phosphate (Colon)	A	A	-	A	A
met silicate	A	A	-	A	A
nitrate (saltpetre)	B	A	D	A	A
perforate	B	A	B	A	A
peroxide	B	A	D	A	A
phosphate primary	A	A	D	A	A
phosphate secondary	A	A	D	A	A

+ TECH TECHNICAL SHEETS

www.gemels.it

	NBR	FKM	MQV	EPDM	FFKM
Sali di nichel	A	A	A	A	A
Sali di potassio	A	A	A	A	A
Sali di rame	A	A	A	A	A
Sali di sodio	A	A	A	A	A
Sali di zinco	A	A	A	A	A
Sebacato di dienzolo	D	B	C	B	A
Sebacato di dibutile	D	B	B	B	A
Sebacato di dietile	D	B	B	B	A
Sebacato di diisottano	C	B	C	C	A
Sebacato di diottile (DOS)	D	B	C	B	A
Silicato d'etile	A	A	B	A	A
Silicato di calcio	A	A	-	A	A
Soda (carbonato d'azoto)	A	A	A	A	A
Solfato d'alluminio	A	A	A	A	A
Solfato d'ammonio	A	D	B	A	A
Solfato di magnesio	A	A	A	A	A
Solfato di nichel	A	A	A	A	A
Solfato di piombo	B	A	B	A	A
Solfato di potassio	A	A	A	A	A
Solfato di sodio (Sale di Glauber)	A	A	A	A	A
Solfato di zinco	A	A	A	A	A
Solfito di calcio	A	A	A	A	A
Solfito di potassio	A	A	A	A	A
Solfito di sodio	A	A	A	A	A
Solfuro d'ammonio	A	D	B	A	A
Solfuro di bario	A	A	A	A	A
Solfuro di calcio	A	A	A	A	A
Solfuro di carbonio	D	A	D	D	A
Solfuro di sodio	A	A	A	A	A
Soluzione di coliche	B	-	-	B	A
Soluzione di persolfato d'ammonio	D	-	-	A	A
Soluzione di potassio	A	A	B	A	A
Soluzione saponosa	A	A	A	A	A
Soluzioni di idrossido di potassio (diluite)	B	B	B	A	A
Soluzioni zuccherine	A	A	A	A	A
Solventi per vernici	D	D	D	D	A
Stearato di butile	B	A	B	D	A
Stirene (monomero)	D	B	D	D	A1
Strutto, grasso animale	A	A	B	B	A

T

Taglio di piombo tetraetile	B	A	D	D	A
Tetrabromoetano	D	A	D	D	A
Tetracloroetilene (Percloroetilene "Tetra")	B	A	D	D	B
Tetracloruro di carbonio	B	A	D	D	B
Tetracloruro di titanio	B	A	D	D	A
Tetraidrofurano	D	D	D	B	A
Tetralina	D	A	D	D	A
Tiosolfato di calcio	B	A	A	A	A
Tiosolfato di sodio (sale di fissaggio)	B	A	A	A	A
Titanato tetrabutile	B	A	-	A	A
Toluolo	D	A	D	D	A
Triacetato di glicerina	B	D	B	A	A
Tricolroetano	D	A	D	D	A
Tricloroetilene ("Tri")	D	A	D	D	A

	NBR	FKM	MQV	EPDM	FFKM
phosphate tertiary	A	A	A	A	A
sulphate (Gluer's salt)	A	A	A	A	A
sulphide	A	A	A	A	A
sulphite	A	A	A	A	A
thiosulphate (fixer)	B	A	A	A	A
Soya oil	A	A	A	C	A
Stannic chloride	A	A	B	A	A
50%	A	A	B	A	A
Stannous Chloride	A	A	B	A	A
Steam below 150°C	D	C	C	A	A
above 150°C	D	D	D	B	A
Satiric acid	B	A	B	B	A
Styrene (monomer)	D	B	D	D	A1
Sugar cane solution	A	A	A	A	A
Sugar solutions	A	A	A	A	A
Sugar-beet juice	A	A	A	A	A
Sulphur	D	A	B	A	A
Sulphur chloride D	A	C	D	D	A
Sulphur dioxide aqueous	D	D	B	A	A
dry	D	D	B	A	A
liquid under pressure	D	D	B	A	A
Sulphur hexafluoride	B	C	B	A	B
Sulphur trioxide, dry	D	A	B	B	A
Sulphuric acid 3-molar	D	A	D	B	A
concentrated	D	A	D	D	A
fuming (20/25% Oleum)	D	A	D	D	A
Sulphurous acid	B	A	D	B	A
Super grade petrol	A	A	D	D	A

T

Tar (bituminous)	B	A	B	D	A
Tartaric acid	A	A	A	B	A
Tetrabromethane	D	A	D	D	A
Tetrabutyl titanate	B	A	-	A	A
Tetrachloroethylene (perchloroethylene dry cleaning fluid)	B	A	D	D	B
Tetraethyl lead	B	A	D	D	A
Tetraethyl chips	B	A	D	D	A
Tetrahydrofurane	D	D	D	B	A
Tetraline	D	A	D	D	A
Titanium (IV) chloride	B	A	D	D	A
Toluene	D	A	D	D	A
Toluylene diisocyanate	D	D	D	B	A
Transformer oil	A	A	B	D	A
Transmission fluid type A	A	A	B	D	A
Triaryl phosphate	D	A	C	A	A
Tributoxyethyl phosphate	D	A	-	A	A
Tributyl mercaptan	D	A	D	D	A
phosphate	D	D	D	A	A
Trichloroacetic acid	B	C	C	A	A
Trichloroethane	D	A	D	D	A
Trichloroethylene (Trilene)	D	A	D	D	A
Trichlorometane (Chloroform)	D	A	D	D	A
Triethanolamine	C	D	D	B	A1
Trifluoroethane	D	A	D	D	B
Trinitrotoluene	D	B	-	D	A

	NBR	FKM	MQV	EPDM	FFKM
Triclorometano (Cloroformio)	D	A	D	D	A
Tricloruro d'etilene ("Tri")	D	A	D	D	A
Tricloruro di fosforo	D	A	D	A	A
Trietanolamina	C	D	D	B	A1
Trifluoretano di bromo-cloro	D	A	D	D	A
Trifluoroetano	D	A	D	D	B
Trifluoruro di bromo	D	D	D	D	B
Trifluoruro di cloro	D	D	D	D	B
Trinitrotoluolo	D	B	-	D	A
Triossido di zolfo, secco	D	A	B	B	A
Tripolifosfato	D	B	C	A	A

V

Vapore	fino a 150°C	D	C	C	A	A
	oltre 150°C	D	D	D	B	A
Vapori di mercurio	A	A	A	A	A	
Vaseline	A	A	D	D	A	
Vernici	B	A	D	D	A	
Vernici all'anilina	D	B	C	B	A	
Vino e Whiskey	A	A	A	A	A	

W

White oil	A	A	D	D	A
Wood oil	A	A	D	D	A
Wood vinegar	D	D	-	B	A

X

Xenon	A	A	A	A	A
Xilidina (miscela di amine aromatiche)	C	D	D	D	A1
Xilolo	D	A	D	D	A

Z

Zeolite	A	A	A	A	A
Zolfo	D	A	B	A	A
Zolfo clorato	D	A	C	D	A
Zolfo fuso	D	A	C	C	A
Zucchero di barbabietole (soluzioni)	A	A	A	A	A
Zucchero di canna (soluzione)	A	A	A	A	A

LEGENDA

A	Resistente
B	Utilizzabile
C	Limitatamente utilizzabile
D	Non resistente
-	Non disponibile

- 1 Dipendente dal compound. Interpellateci
- 2 Per O-Ring in RPTFE vergine ed O-Ring ricoperti con FEP e FPA
- 3 Per O-Ring e C-Ring metallici

I dati sono basati su prove condotte sotto condizioni differenti. Tuttavia nella maggior parte dei casi i valori sono stati determinati a temperatura ambiente e con un tempo d'azione di 7 giorni (150 ore). In alcuni casi singoli delle determinazioni discordanti tra il laboratorio e la pratica sono del tutto possibili. A causa dei differenti parametri impiegati e della composizione dei mezzi, questi dati sono solo indicativi. Per questa ragione non possiamo assumerne nessuna responsabilità per l'esattezza delle nostre raccomandazioni in singoli casi. Invitiamo ad interpellarci in condizioni di servizio eccezionali.

"The company reserves the right to operate dimensional changes without prior notice".

	NBR	FKM	MQV	EPDM	FFKM
Triocetyl phosphate	D	B	C	A	A
Triothocresylphosphate ("TOCP")	D	B	C	A	A
Tripolyphosphate	D	B	C	A	A
Tung oil (China wood oil)	A	A	D	D	A
Turpentine	A	A	D	D	A

V

Vaseline	A	A	D	D	A
Vegetable oils	A	A	A	C	A
Vinegar (%% actic acid)	B	A	A	A	A
Vinyl acetylene	A	A	B	A	A

W

Waste water	A	A	A	A	A
Water (for industrial use) up to 70°C	A	B	A	A	A
	100°C	B	B	B	A
White oil	A	A	D	D	A
White pine oil	B	A	D	D	A
Wine and Whisky	A	A	A	A	A
Wolman's salt (wood impregnation)	A	A	A	A	A
Wood oil	A	A	D	D	A
Wood vinegar	D	D	-	B	A

X

Xenon	A	A	A	A	A
Xylene	D	A	D	D	A
Xylidine (mixture of aromatic amines)	C	D	D	D	A1

Z

Zeolites	A	A	A	A	A
Zinc acetate	B	D	D	A	A
	chloride	A	A	A	A
	sulphate	A	A	A	A

LEGEND

A	Stable
B	Can be used
C	Limited stability (use not recommended)
D	Not stable
-	Data not available

The information on the following pages is based on tests under various different conditions. Many of the values have been determined at room temperature with a reaction time of 7 days (150 hours). In individual cases observations may differ between laboratory and practical tests. Because of differences in conditions of use and the composition of fluids the data given are only guidelines and should not be taken as binding. For these reasons we cannot give any guarantees as to the correctness of our recommendations in individual cases. If your operating conditions are unusual please feel free to discuss them with us.

Tenute sfere Materiali standard

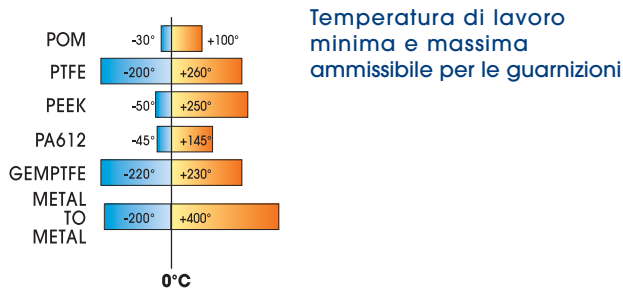

Ball seats - Main materials & specifications

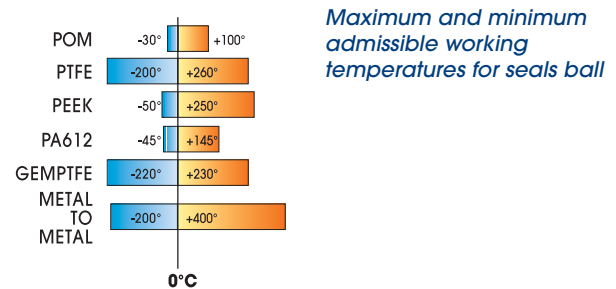

PA612 (Poliammide):

I poliammidi sono dei materiali tecnoplastici utilizzati da lungo tempo che presentano delle caratteristiche rilevanti, pur mantenendo un ottimo rapporto qualità/prezzo. Essi si distinguono per le loro ottime proprietà meccaniche unite ad una grande resistenza agli urti. Il comportamento all'usura è superiore alla media. I differenti tipi di poliammidi sono contrassegnati da un sistema di identificazione internazionale basato sul numero di atomi di carbonio per monomero.



PA612 (Polyamide):

Polyamides are well proven engineering polymers with very interesting properties and a favourable price. They are characterized by high mechanical stability values combined with excellent impact strength. They have an above average wear rate. The different types of polyamides are distinguished by an international identification system based on the number of carbon atoms per monomer.

PEEK (Polietereterchetone):

I semilavorati PEEK sono a base di resina di polietereterchetone, un polimero lineare aromatico. Questo materiale ideale per applicazioni estremamente severe in termini di temperatura, di aggressione chimica, di resistenza alle radiazioni ad alta energia, ed infiammabilità.



PEEK (Polyether etherketone):

Semi-finished products are based on polyether etherketone as the raw material, a linear, aromatic polymer. It is an ideal material for applications where high performance is demanded under extreme conditions with regard to temperature, chemicals, high powered radiation and non-flammable, etc.

POM (Poliossimetilene):

Si tratta di un materiale termoplastico fortemente cristallino, molto utilizzato come materiale tecnoplastico. Il POM unisce una grande durezza ed una buona stabilità dimensionale ad una grande resistenza agli urti, il che lo rende un materiale preferito per la costruzione di macchine e di apparecchi di precisione. Le sue caratteristiche di scorrimento sono anche molto elevate.



POM (Polyoxymethylene):

A highly crystalline thermoplastic with special importance as a technical plastic. POM combines a high level of hardness and form stability with a high resistance to impact. Accordingly, it's a highly suitable for the construction of precision machinery and apparatus. It has remarkable sliding properties.

PTFE (Politetrafluoroetilene):

Il politetrafluoroetilene è un polimero a struttura macromolecolare lineare derivato dalla polimerizzazione del tetrafluoroetilene. Al di sopra del suo punto di fusione a +327°C, il PTFE passa allo stato di gelificazione. La sua viscosità elevata non permette la lavorazione termoplastica secondo le tecniche tradizionali, come la stampa ad iniezione e l'estrusione a vite. Il PTFE viene stampato a freddo sotto pressione e quindi sinterizzato. Grazie alla sua combinazione unica di eccezionali caratteristiche tecniche, il PTFE può essere considerato come un materiale tecnoplastico di qualità superiore.



PTFE (Polytetrafluoroethylene):

Above the melting point of +327°C, PTFE changes into a gel-like state. Its high viscosity excludes the possibility of thermoplastic processing by traditional methods, such as injection moulding and screw extrusion. PTFE is cold extruded and subsequently sintered. Due to its unique combination of outstanding characteristics, PTFE can be called an engineered polymer of outstanding quality.

GEMPTFE e l'RPTFE:

Il GEMPTFE e l'RPTFE sono costruiti con lo stesso procedimento del PTFE ma viene caricato con una percentuale del 25%, rispettivamente, di vetro pigmentato blu e di carbonografite che determinano una maggiore resistenza meccanica.



GEMPTFE and RPTFE:

GEMPTFE and RPTFE seals are made with the same procedure of PTFE, but the solution is provided by using special fillers; 25% of glass blue pigment for GEMPTFE and 25% carbon graphite for RPTFE that creates a major mechanical resistance.

Tenute sfere Proprietà fisiche dei materiali per usi tecnici

Proprietà	Metodo di prova	Unità di misura	PA	PEEK	POM	PTFE	GEMPTFE	
Peso specifico	DIN 53479	g/cm ³	1.14	1.31	1.41	2.18	2.19	
Assorbimento d'acqua	amb. Normale +23°C/50% U.R.	%	2.6	0.2	0.2	<0.01	<0.01	
	in acqua a +23° C	%	9	0.45	0.85	<0.01	<0.01	
Resistenza σ_s (a trazione)	tr DIN 53455	N/mm ²	76	110	68	~ 30	~ 31	
	lf DIN 53455	N/mm ²	45		68			
Allungamento a rottura ϵ_R (a trazione)	tr DIN 53455 %	>50	20	35	350	350		
	lf DIN 53455 %	>100			35			
Modulo di elasticità (a trazione)	tr DIN 53457	N/mm ²	3250	4400	3100	550	550	
	lf DIN 53457	N/mm ²	1400		3100			
Carico ammissibile a compressione (con Deformazione sotto carico	2%)(1% per RPTFE) lf DIN 53444 (ASTM D 695)	N/mm ²	15	57	26	5	5	
	ASTM D 621					15	15	
Deformazione permanente	ASTM D 622				8.1	8.2		
Resistenza agli urti provetta con intaglio	Charpy tr DIN 53453	kJ/m ²	5.5	3.5	7	16	16	
	Izod lf DIN 53453	kJ/m ²	15		7			
Durezza Brinell (3)	tr ISO 2039-1	N/mm ²	150	230	140	27	27	
Durezza	ASTM D 2240					55	55	
Durezza Rockwell (4)	lf ISO 2039-2	–	M85	M105	M84			
Resistività trasversale (5)	tr DIN 53481/0303 T2	kV/mm	25	24	20	1018	1018	
	lf	kV/mm	16		20			
Resistenza superficiale	tr DIN 53482/0303 T3	Ω -cm	>1014	1016	>1014	1017	1017	
	lf	Ω -cm	>1014		>1013			
Resistenza superficiale	tr DIN 53482/0303 T3	Ω	>1013	1016	>1013			
Costante dielettrica	100Hz	lf DIN 53483/0303 T4	3.9	3.2	3.8	2.1	2.1	
		lf	7.4		3.8			
	1MHz	tr DIN 53483/0303 T4	3.3	3.2	3.8	2.1	2.1	
		lf	3.8		3.8			
Fattore di dissipazione dielettrica con tan	100Hz	tr DIN 53483/0303 T4	0.019	0.001	0.003	<0.0003	<0.0003	
		lf	0.13		0.003			
	1MHz	tr DIN 53483/0303 T4	0.021	0.002	0.008	<0.0003	<0.0003	
		lf	0.06		0.008			
Resistenza alle correnti di dispersione	tr+lf IEC 112/0303 T1	CTI	600	150	600	600	600	
Punto di fusione	DIN 53736	°C	220	340	165	327	327	
Conducibilità termica	DIN 52612	W/(K-m)	0.28	0.25	0.31	0.23	0.24	
Coeff. di dilatazione termica lineare	+23°C a +60°C	DIN 52328	1/K-10 ⁻⁶	90	50	110	160	160
	+60°C a +100°C		1/K-10 ⁻⁶	105	50	125	180	180
Temperatura di flessione sotto carico (HDT)	DIN 53461	°C		70	160	105		
Temperatura d'esercizio (HDT)	in continuo	–	°C	85	250	115	+260	+260
	brevi periodi	–	°C	160	310	140	+280	+280
Resistenza alle basse temperature	–	–	°C	-40	-60	-50	-200	-200
Resistenza alla fiamma	indice d'ossigeno	ASTM 4589	%	25	35	15	95	95
		UL 94	classe	HB	V-0	HB		
Coefficiente d'attrito μ	dinamico	–	–	0.40-	0.25-	0.30-		
		–	–	0.60	0.50	0.45		
Coefficiente d'attrito statico	–	–				0.05-	0.05-	
Coefficiente d'attrito dinamico	ASTM D 3702	–	–			0.10	0.11	
		–	–			0.06-	0.06-	
Usura per attrito	–	–	μ m/km	19	28	45	–	

Ball seats Physical properties of plastic material for technical use

Properties	Test method	Unit	PA	PEEK	POM	PTFE	GEMPTFE	
Specific gravity	DIN 53479	g/cm ³	1.14	1.31	1.41	2.18	2.19	
Water absorption	Standard climate at +23°C/50% U.R.	%	2.6	0.2	0.2	<0.01	<0.01	
	in water at +23° C	%	9	0.45	0.85	<0.01	<0.01	
Tensile strength σ_s	tr DIN 53455	N/mm ²	76	110	68	~30	~31	
	lf DIN 53455	N/mm ²	45		68			
Tensile ultimate elongation ϵ_R	tr DIN 53455	%	>50	20	35	350	350	
	lf DIN 53455	%	>100		35			
Tensile modulus of elasticity	tr DIN 53457	N/mm ²	3250	4400	3100	550	550	
	lf DIN 53457	N/mm ²	1400		3100			
Admissible compression load (with 2%)(1% for rptfe) Deformation under load	lf DIN 53444 (ASTM D 695)	N/mm ²	15	57	26	5	5	
	ASTM D 621					15	15	
Permanent deformation	ASTM D 622					8.1	8.2	
Shock proof resistance	Charpy	tr DIN 53453	kJ/m ²	5.5	3.5	7	16	16
	Izod	lf DIN 53453	kJ/m ²	15		7		
Brinell hardness (3)	tr ISO 2039-1	N/mm ²	150	230	140	27	27	
Hardness	ASTM D 2240					55	55	
Rockwell hardness (4)	lf ISO 2039-2	–	M85	M105	M84			
Transversal resistivity (5)	tr DIN 53481/0303 T2	kV/mm	25	24	20	1018	1018	
	lf	kV/mm	16		20			
Surface resistivity	tr DIN 53482/0303 T3	Ω -cm	>1014	1016	>1014	1017	1017	
	lf	Ω -cm	>1014		>1013			
Surface resistivity	tr DIN 53482/0303 T3	Ω	>1013	1016	>1013			
	lf	Ω	>1012		>1013			
Dielectric constant	100Hz	lf DIN 53483/0303 T4	3.9	3.2	3.8	2.1	2.1	
		lf	7.4		3.8			
	1MHz	tr DIN 53483/0303 T4	3.3	3.2	3.8	2.1	2.1	
		lf	3.8		3.8			
Dielectric loss factor tan	100Hz	tr DIN 53483/0303 T4	0.019	0.001	0.003	<0.0003	<0.0003	
		lf	0.13		0.003			
	1MHz	tr DIN 53483/0303 T4	0.021	0.002	0.008	<0.0003	<0.0003	
		lf	0.06		0.008			
Leakage current resistance	tr+lf IEC 112/0303 T1	CTI	600	150	600	600	600	
Melting point	DIN 53736	°C	220	340	165	327	327	
Thermal conductivity	DIN 52612	W/(K-m)	0.28	0.25	0.31	0.23	0.24	
Linear thermal expansion coefficient	+23°C a +60°C	DIN 52328	1/K·10 ⁻⁶	90	50	110	160	160
	+60°C a +100°C		1/K·10 ⁻⁶	105	50	125	180	180
Deflection temperature under load (HDT)	DIN 53461	°C	70	160	105			
Working temperature (HDT)	for cont. service	–	°C	85	250	115	+260	+260
	for short period	–	°C	160	310	140	+280	+280
Low temperature resistance	–	–	°C	-40	-60	-50	-200	-200
Flame resistance	oxygen index	ASTM 4589	%	25	35	15	95	95
		UL 94	classe	HB	V-0	HB		
Friction coefficient μ	dynamic	–	–	0.40-	0.25-	0.30-		
		–	–	0.60	0.50	0.45		
Static friction coefficient	–	–				0.05-	0.05-	
Dynamic friction coefficient	ASTM D 3702	–	–			0.10	0.11	
		–	–			0.06-	0.06-	
Wear rate	ASTM D 3702	–	–	19	28	45	–	–
		–	–					

Tenute sfere Resistenza chimica

Materiale	Abbreviazione	Osservazioni	Temp. ammissibile (Acqua)°C	
			Costante	Breve Tempo
Polyvinilidene Fluoride	PVDF	Resistente agli acidi, soluzioni saline, idrocarburi clorurati, aromatici e alifatici, alcol e alogeni. Sotto certe condizioni è indicato per chetoni, esteri, basi organiche e soluzioni alcaline.	140°	150°
Polyoxymethylene	POM	Resistente a molti solventi. Non consigliato per gli acidi.	60°	80°
Polytetrafluoroethylene	PTFE	Resistente a tutti gli agenti chimici di questa lista.	250°	300°
Nitrile Rubber	NBR	Buona resistenza ad olio e petrolio. Sconsigliato per materiali soggetti ad ossidazione.	90°	120°
Butyl Rubber Ethylene Propylene Rubber	EPDM	Buona resistenza all'ozono e agli agenti atmosferici. Specialmente indicato per agenti chimici aggressivi. Sconsigliato per oli e grassi.	90°	120°
Fluorine Rubber	FPM	Ha la migliore resistenza chimica ai solventi e a tutti gli elastomeri.	150°	200°
Polytetrafluoroethylene Special Gemels seals	GEMPTFE	Resistente a tutti gli agenti chimici di questa lista con utilizzo anche ad alte pressioni.	250°	300°

Ball seats Chemical resistance

Material	Abbreviation	Remarks	Maximum Admissible Temp. (Water)°C	
			Constant	Short term
Polyvinilidene Fluoride	PVDF	Resistant to acids, solutions of salts, aliphatic, aromatic and chlorinated hydrocarbons, alcohols and halogens. Conditionally suitable for ketones, esters, organic bases and alkaline solutions.	140°	150°
Polyoxymethylene	POM	Resistant to most solvents and hydrous alkalis. Unsuitable for acids.	60°	80°
Polytetrafluoroethylene	PTFE	Resistant to all chemicals in this list.	250°	300°
Nitrile Rubber	NBR	Good resistance to oil and petrol. Unsuitable for materials subject to oxidation.	90°	120°
Butyl Rubber Ethylene Propylene Rubber	EPDM	Good resistance to ozone and weather. Especially suitable for gressive chemicals. Unsuitable for oils and fats.	90°	120°
Fluorine Rubber	FPM	It has best chemical resistance to solvents of all elastomers.	150°	200°
Polytetrafluoroethylene Special Gemels seals	GEMPTFE	Resistant to all chemicals in this list, possibility use also high pressure.	250°	300°

Tenute sfere Resistenza chimica ai fluidi

	PEEK	POM	PTFE	GEMPTFE	PA612
A					
Acetaldeide 40%	A	A	A	A	B
Acetammide 50%	A	A	A	A	A
Acetato butilico	A	A	A	A	A
Acetato metilico	A	A	A	A	A
Acetato di etile	A	A	A	A	A
Acetilene	A	A	A	A	-
Aceto	A	A	A	A	-
Acetone	A	A	A	A	B
Acidi grassi 100°C	A	A	A	A	-
Acidi grassi 200°C	B	-	A	A	-
Acido acetico concentrato	C	B	A	A	C
Acido acetico, acquoso al 10%	A	A	A	A	C
Acido acetico, acquoso al 5%	A	A	A	A	A
Acido borico, acquoso al 10%	C	A	A	A	A
Acido citrico, acquoso al 10%	A	B	A	A	B
Acido cloridrico, acquoso al 36%	A	C	-	-	C
Acido cloridrico, acquoso al 10%	A	C	-	-	C
Acido cloridrico, acquoso al 2%	A	A	A	A	C
Acido di cromo 10%	A	C	A	A	C
Acido fluoridrico, 40%	-	C	A	A	C
Acido formico, acquoso al 10%	A	A	A	A	C
Acido fosforico, acquoso al 10%	A	B	A	A	C
Acido fosforico concentrato	A	-	A	A	C
Acido glicolico	A	-	A	A	-
Acido idroclorico 36%	A	-	A	A	-
Acido idroclorico 2%	A	-	A	A	-
Acido idrofluorico	C	-	A	A	-
Acido lattico, acquoso al 10%	A	A	A	A	A
Acido lattico, acquoso al 90%	A	A	A	A	C
Acido nitrico, acquoso 2%	A	C	A	A	C
Acido nitrico, concentrato 65%	B	C	A	A	C
Acido oleico 100°C	A	A	A	A	A
Acido oleico 200°C	B	-	A	A	-
Acido ossalico, acquoso al 10%	A	C	A	A	B
Acido salicilico	-	-	A	A	A
Acido solforico, conc. al 98%	C	C	A	A	C
Acido solforico, conc. al 10%	A	C	A	A	C
Acido solforico, Acquoso al 2%	A	A	A	A	C
Acido tartarico	A	B	A	A	A
Acqua calda	A	B	A	A	B
Acqua clorica	A	C	-	-	-
Acqua di mare	A	A	-	-	-
Acqua, fredda	A	A	A	A	A
Acqua ossigenata 10%	A	A	-	-	C
Acqua ossigenata 3%	A	A	-	-	B
Acqua ossigenata 1%	A	A	-	-	A

Ball seats Chemical resistance to fluids

	PEEK	POM	PTFE	GEMPTFE	PA612
A					
Acetamide 50%	-	-	A	A	A
Acetic acid conc.	A	B	A	A	C
Acetic acid 10%	A	A	A	A	C
Acetic acid 5%	A	A	A	A	A
Acetic acid ethyl ester	A	A	A	A	B
Acetone	A	A	A	A	B
Acetylene (ethin)	A	A	A	A	B
Air	A	A	A	A	B
Ammonium chloride	B	B	A	A	B
Ammonia 10%	A	A	A	A	A
Amyl Alcohol	B	-	A	A	-
Aniline	A	A	A	A	B
Argon, gaseous	A	A	A	A	A
ATE brake fluid	A	A	A	A	A
B					
BeerA	B	A	A	A	
Beet sugar juice	A	A	A	A	A
Benzene	A	A	A	A	B
Benzine, leaded	A	A	A	A	A
Bitumen	-	A	A	A	B
Borax	A	A	A	A	A
Boric acid 10%	A	A	A	A	A
Brine	A	A	A	A	A
Bromine	B	-	A	A	-
Butane	A	A	A	A	A
Butylacetate	-	A	A	A	A
Butylene glycol	A	-			
C					
Calcium chloride 10%	A	A	A	A	A
Carbon dioxide, dry	A	-	A	A	-
Carbon dioxide, wet	A	-	A	A	A
Carbon disulphide	A	-	A	A	-
Carbonlineum	A	-	A	A	-
Carbon tetrachloride	A	A	A	A	A
Chlorine 100°C	B	-	A	A	-
Chlorine water	B	-	A	A	-
Chlorobenzene	A	-	B	B	-
Chloroform	-	C	A	A	B
Chromic acid	B	-	A	A	-
Citric acid 10%	A	A	A	A	B
Clophen A 80 50%	-	A	A	A	A
Coconut oil	A	-	A	A	B
Coffee	A	-	A	A	-
Copper sulphate	-	-	A	A	A
Cyclohexane	A	A	A	A	A
Cyclohexanol	-	A	A	A	B

	PEEK	POM	PTFE	GEMPTFE	PA612
Acqua ossigenata 0,5%	A	A	-	-	A
Acrilnitrile	A	B	A	A	A
Alcol allilico	A	B	-	-	B
Alcol amilico	B	-	A	A	-
Alcol benzilico	A	A	A	A	-
Alcol isopropilico (fino a 48° C)	A	A	A	A	-
Allume di cromo 10%	A	C	-	-	-
Ammoniaca, acquoso al 10%	A	A	A	A	A
Anilina	-	B	A	A	B
Anone	A	-	A	A	A
Aria A	A	-	-	-	-
Argon	A	A	A	A	A

B

Benzaldeide (Fino a 22°C)	A	A	A	A	B
Benzene	A	A	A	A	B
Benzina	A	A	A	A	A
Benzolo	A	A	A	A	A
Benzolo di cloro	A	A	-	-	A
Bicromato potassico, acquoso al 10%	A	A	A	A	A
Birra	A	B	A	A	A
Bisolfito di sodio, acquoso al 10%	A	C	A	A	A
Bitume	-	A	A	A	B
Butanolo	A	A	-	-	A
Butilacetato	-	A	A	A	A

C

Caffè	A	-	A	A	-
Carbonato di potassio	A	-	A	A	-
Carbonato di sodio, acquoso al 10%	A	A	A	A	A
Catrame	-	-	A	A	B
Cera fusa	A	A	A	A	A
Chetone etimetilico	A	B	-	-	A
Cicloesano	A	A	A	A	B
Cicloesanone	-	A	A	A	A
Clofene A 80 50%	-	A	A	A	A
Clorobenzolo	-	A	A	A	B
Cloroformio	-	C	A	A	C
Cloruro di alluminio	A	B	A	A	B
Cloruro di ammonio	A	A	A	A	A
Cloruro di calcio, acquoso al 10%	A	A	A	A	A
Cloruro di calcio, alcolico	A	A	A	A	A
Cloruro di etile	B	B	A	A	-
Cloruro di etilene	B	C	A	A	B
Cloruro di ferro	A	B	A	A	A
Cloruro di magnesio	A	A	A	A	A
Cloruro di metilene	A	B	A	A	C
Cloruro di sodio, acquoso al 10%	A	A	A	A	A
Cloruro di zinco, acquoso al 10%	A	A	A	A	B
Combustibile diesel	A	A	A	A	A

	PEEK	POM	PTFE	GEMPTFE	PA612
Cyclohexanone	-	A	A	A	A

D

Diacetone alcohol	B	-	A	A	-
Diesel oil	A	A	A	A	B
Dichlorbenzene	B	-	A	A	B
Diethylene glycol	A	A	A	A	-
Dimethylformamide	A	A	C	C	C
Dimethyl Ketone (acetone)	A	-	A	A	-
Diocetylphthalate	-	A	A	A	A
Dioxan	A	B	A	A	A

E

Edible oil, Edible fat	A	-	A	A	A
Ethandiol	-	-	A	A	B
Ethane	-	A	A	A	A
Ethanol 96%	A	A	A	A	A
Ether	-	B	A	A	-
Ethyl Acetate	A	B	A	A	B
Ethyl alcohol	A	A	A	A	B
Ethyl benzene	A	A	A	A	B
Ethylene	A	A	A	A	B
Ethylene glycole	A	B	A	A	B
Ethylene trichloride (Tri)	A	B	A	A	B
Ethylene Chloride	B	C	A	A	B

F

Fatty acids 100°C	A	A	A	A	-
Fatty acids 200°C	B	-	A	A	-
Ferric chloride	B	-	A	A	A
Flue gas	A	A	A	A	A
Formaldehide 30%	A	A	A	A	A
Formamide	-	-	A	A	A
Formic acid 10%	A	A	A	A	C
Freon 11,13,14,32	B	-	A	A	B
Freon 22,31,114,115	B	-	A	A	B
Frigen	C	-	-	-	-
Fruit juices	A	-	A	A	A
Fuel oil	A	-	A	A	B

G

Gasoline	A	A	A	A	A
Gelatine	A	A	A	A	A
Glucose	A	A	A	A	B
Glycerine	A	A	A	A	A
Glycol	A	A	A	A	B
Glycol acids	A	-	A	A	-
Glystantin 40%	A	A	A	A	A
Grease	A	A	A	A	A

H

Helium, gaseous	A	A	A	A	A
Heptane	A	A	A	A	A
Hexane	A	A	A	A	A

+ TECH TECHNICAL SHEETS

www.gemels.it

	PEEK	POM	PTFE	GEMPTFE	PA612
--	------	-----	------	---------	-------

D					
Decalina	A	A	A	A	A
Diactiftalato	-	A	A	A	A
Diammina di etilene	-	A	A	A	A
Dimetilformammide	A	A	C	C	C
Diossano	A	B	A	A	A
Diossido di carbonio, secco	A	-	A	A	A
Diossido di carbonio, umido	A	-	A	A	A

E					
Elio, gassoso	A	A	A	A	A
Eptano,	A	A	A	A	A
Esano	A	A	A	A	A
Etanolo 96%	A	A	A	A	A
Etere di etile	A	A	-	-	A
Etilacetato	A	B	A	A	A
Etiletere	-	A	A	A	A

F					
Fenolo, acquoso	A	C	A	A	C
Formaldeide, acquoso al 30%	A	A	A	A	A
Formammide	-	-	A	A	A
Freon, frigen, liquido	C	-	A	A	A
Ftalato dibutilico	A	A	-	-	A
Ftalato dioctilico	A	A	-	-	A
Furfurolo	-	A	-	-	A

G					
Gas clorico	-	C	-	-	C
Gasolio	A	A	A	A	A
Gelatina	A	A	A	A	A
Glicerina	A	A	A	A	A
Glicole	A	A	A	A	A
Glisantina, acquosa al 40%	A	A	A	A	A
Glucosio	A	A	A	A	B
Grassi alimentari, oli alimentari	A	A	A	A	A

I					
Idrogeno solforato, saturo	A	-	A	A	A
Idrossido di potassio, acquoso al 10%	A	A	A	A	A
Idrossido di potassio, acquoso al 50%	A	A	A	A	A
Idrossido di sodio 50%	A	-	A	A	C
Idrossido di sodio 10%	A	-	A	A	B
Inchiostro	A	-	A	A	A
Isopropranololo	A	A	A	A	A
Isottano	A	-	A	A	A

K					
Kerosene	A	B	A	A	B

L					
Latte	A	A	A	A	A

	PEEK	POM	PTFE	GEMPTFE	PA612
--	------	-----	------	---------	-------

Hydrochloric acid 36%	A	-	A	A	-
Hydrochloric acid 2%	A	-	A	A	-
Hydrofluoric acid	C	-	A	A	-
Hydrogen peroxide 30%	B	C	A	A	C
Hydrogen peroxide 0,5%	A	A	A	A	C
Hydrogen sulphide	A	-	A	A	-

I					
Ink A	A	A	A	A	
Isobutylalcohol	B	-	A	A	-
Isocyanat	A	A	A	A	B
Isooctane	A	-	A	A	B
Isopropanol	A	A	A	A	A
Isopropylalcohol	B	B	A	A	B

K					
Kerosene	A	B	A	A	B

L					
Lactic acid 90%	A	A	A	A	C
Lactic acid 10%	A	A	A	A	A
Linseed oil	A	A	A	A	A

M					
Magnesium chloride	A	A	A	A	B
Margarine	A	A	A	A	A
Menthol	A	-	A	A	-
Mercury	A	A	A	A	A
Merury dichloride	B	-	A	A	A
Mercury monochloride	B	-	A	A	-
Methane	A	A	A	A	A
Methanol	A	A	A	A	A
Methyl ethyl ketone	A	B	A	A	A
Methylene chloride	A	B	A	A	C
Milk A	A	A	A	A	
Motor oil/Engine oil	A	A	-	-	-

N					
Naphta (stone-oil)	A	A	A	A	A
Naphtalene	A	A	A	A	A
Neon, gaseous	A	A	A	A	A
Nitric acid 2%	A	C	A	A	C
Nitrobenzene	A	-	A	A	B

O					
Octane	A	A	A	A	A
Oleic acid 100°C	A	A	A	A	A
Oleic acid 200°C	B	-	A	A	-
Olive oil	A	A	A	A	A
Oxygen, gaseous 60°C	A	A	A	A	-
Oxalic acid 10%	A	C	A	A	B
Ozone	A	C	A	A	B

	PEEK	POM	PTFE	GEMPTFE	PA612
--	------	-----	------	---------	-------

M

Margarina	A	A	A	A	A
Mentolo	A	-	A	A	-
Mercurio	A	A	A	A	A
Mercurio acquoso	A	-	A	A	C
Metano	A	A	A	A	A
Metanolo	A	A	A	A	A
Metiltilchetone	A	B	A	A	A

N

Nitrato di potassio	A	B	A	A	A
Nafta pesante	-	A	A	A	A
Naftalina	A	A	A	A	A
Neon	A	A	A	A	A
Nitrato di sodio, acquoso al 10%	-	A	A	A	A
Nitrobenzolo	A	B	A	A	B

O

Oli silicnici	A	A	A	A	A
Olio di cocco	A	-	A	A	B
Olio di lino	A	A	A	A	A
Olio di oliva	A	A	A	A	A
Olio di paraffina	A	A	A	A	A
Olio di soia	A	A	A	A	A
Olio minerale	A	A	A	A	A
Olio per trasformatori	A	A	A	A	A
Ossigeno, gassoso 60°C	A	C	A	A	-
Ottani	A	A	A	A	A
Ozono	A	C	A	A	B

P

Pectina	B	-	A	A	-
Percloroetilene	A	A	A	A	B
Permanganato potassico, acquoso al 1%	A	A	A	A	C
Perossido di idrogeno, acquoso al 30%	B	C	A	A	C
Perossido d'idrogeno, acquoso al 0,5%	A	A	A	A	C
Petrolio	A	A	A	A	C
Piridina	-	A	A	A	A
Potassa caustica acquosa 10%	A	A	-	-	A
Potassa caustica acquosa 50%	A	A	-	-	A
Propano	A	A	A	A	
Propanolo	A	A	A	A	A
Propilene	A	A	A	A	A

S

(m) solfato rameico 10%	A	A	A	A	A
Sego	A	A	-	-	A
Soda caustica, acquosa al 5%	-	A	A	A	A
Soda caustica, acquosa al 10%	A	A	-	-	A
Soda caustica, acquosa al 50%	A	A	A	A	A
Solfato di potassio	B	A	A	A	A
Solfuro di alluminio	A	A	-	-	A

	PEEK	POM	PTFE	GEMPTFE	PA612
--	------	-----	------	---------	-------

P

Paraffin oil	A	A	A	A	B
Pectin	B	-	A	A	-
Perchloroethylene	A	A	A	A	B
Petroleum white spirit	A	-	A	A	C
Phenol, aqueous	A	C	A	A	C
Phosphoric acid 10%	A	B	A	A	C
Potassium carbonate	A	-	A	A	-
Potassium hydroxide solution 50%	A	A	A	A	A
Potassium hydroxide solution 10%	A	A	A	A	A
Potassium dichromate 10%	A	A	A	A	
Potassium permanganate 1%	A	A	A	A	C
Potassium sulphate	B	A	A	A	A
Propane	A	A	A	A	B
Propanol	A	A	-	-	-
Propylene	A	A	A	A	A
Pyridene	-	A	A	A	
P-3 Solution aqueous	-	A	-	-	-

S

Salicylic acid	-	-	A	A	A
Sea water	A	A	A	A	-
Silicone oil	A	A	A	A	A
Soap solution	A	A	A	A	A
Soda solution 10%	A	-	-	-	-
Sodium bisulphite	A	C	A	A	-
Sodium carbonate 10%	A	A	A	A	A
Sodium Chloride 10%	A	A	A	A	A
Sodium Hydroxide solution 50%	A	-	A	A	C
Sodium Hydroxide solution 10%	A	-	A	A	B
Sodium nitrate 10%	-	A	A	A	A
Sodium thiosulphate	-	A	A	A	A
Solvent	A	B	A	A	B
Soybean-oil	A	A	A	A	A
Steam 150°C	A	-	A	A	-
Styrene	A	-	A	A	-
Sulphuric acid 98%	C	C	A	A	-
Sulphuric acid 2%	A	A	A	A	-

T

Tar	A	-	A	A	B
Tartaric acid	A	B	A	A	A
Tetrahydrofuran	-	B	A	A	A
Tetrahydronaphthalene	B	-	-	-	-
Thermo-oil 200°C	A	-	A	A	-
Thermo-oil 250°C	A	-	-	-	-
Tincture of iodine	A	-	A	A	C
Toluene	-	-	A	A	B
Triethanolamine	-	A	-	-	-
Trichloroethylene	A	C	A	A	B
Tylon B 10%	-	-	A	A	A
Turpentine	A	A	A	A	A

+ TECH TECHNICAL SHEETS

www.gemels.it

	PEEK	POM	PTFE	GEMPTFE	PA612
Solfuro di carbonio	–	A	A	A	A
Solfuro di idrogeno	A	–	A	A	–
Solfuro di manganese	–	A	A	A	A
Solfuro di rame	A	A	A	A	B
Solfuro di sodio	–	A	A	A	A
Soluzione alcalina 0,1% cloro attivo	A	C	–	–	C
Soluzione P-3, acquoso	–	A	A	A	A
Soluzione saponata, acquosa	A	A	A	A	A
Solvente	A	B	A	A	B
Stirolo	A	A	A	A	A
Succhi di frutta	–	A	A	A	A

T					
Tar	A	–	A	A	B
Tetracloruro di carbonio	–	A	A	A	A
Tetraidrofurano	–	B	A	A	A
Tetralina	–	A	A	A	A
Tintura di iodio, alcolica	A	–	A	A	C
Tiosolfato di sodio, acquoso al 10%	–	A	A	A	A
Toluolo	A	A	A	A	A
Tricloroetilene	A	C	A	A	B
Trietanolanmina	–	A	A	A	A
Trilon B, acquoso al 10%	–	–	A	A	A
Turpentina	A	A	A	A	A

U					
Urea, acquoso	A	A	A	A	A

U					
Vaselina	A	A	A	A	A
Vapore, 150°C	A	–	A	A	–
Vino, acquavite	–	A	A	A	A

X					
Xilolo	A	A	A	A	A

LEGENDA

A	Resistente
B	Parzialmente resistente
C	Non resistente
–	Non disponibile

Tutti i dati si riferiscono ad una temperatura di 20°C e sono indicativi. Questi dati corrispondono allo stato attuale delle nostre conoscenze, e hanno lo scopo di informare sui nostri prodotti e sulle possibili applicazioni. Non hanno, tuttavia, una garanzia legalmente vincolante della resistenza chimica o l'idoneità per una specifica applicazione. Brevetti commerciali esistenti devono essere tenuti in considerazione. Test standard sono effettuati in atmosfera condizionata standard 23/50 secondo DIN 50014. Per applicazioni specifiche si raccomanda un test pratico per l'idoneità.

"The company reserves the right to operate dimensional changes without prior notice".

	PEEK	POM	PTFE	GEMPTFE	PA612
U					
Urea aqueous	A	A	A	A	B

V					
Vaseline	A	A	A	A	A
Vegetable oil	A	B	A	A	B
Vinegar (5... 10% feed vinegar)	A	A	A	A	B
Vinyl chloride	B	B	A	A	B

W					
Water, cold	A	A	A	A	A
Water, distilled	A	A	A	A	B
Water, hot	A	B	A	A	B
Wax, molten	A	A	A	A	A
Wine, brandy	A	A	A	A	A

X					
Xylene	A	A	A	A	B

Z					
Zinc chloride 10%	A	A	A	A	B

LEGEND

A	Resistant
B	Limited resistance
C	Not resistant
–	Not available

All the data refer to a temperature of 20°C and are not binding. These data represent the state of the art of our knowledge, and have the scope of giving information on our products and their possible applications. These data have not a legally binding guarantee regarding the chemical resistance and the suitability for a specific application. Standard tests are done in a standard conditioned atmosphere 23/50 as stated in DIN 50014. For any specific applications we recommend a practical test for the suitability.

Pressioni massime delle tenute

Seats maximum pressure



SEATS PA612 O-RING NBR (GB)

DN6	PN500
DN10	PN500
DN13	PN500
DN20	PN400
DN25	PN350
DN32-40-50	PN350

SEATS POM O-RINGS NBR (AB)

DN6	PN500
DN10	PN500
DN13	PN500
DN20	PN400
DN25	PN350
DN32-40-50	PN350

SEATS PTFE O-RING NBR (CB) DVGW

DN6	PN100
DN10	PN100
DN13	PN100
DN20	PN100
DN25	PN100

SEATS PEEK O-RING NBR (DB)

DN6	PN500
DN10	PN500
DN13	PN500
DN20	PN400
DN25	PN350
DN32	PN350
DN40	PN350
DN50	PN350

SEATS PTFE O-RING NBR (CE)

DN6	PN350
DN10	PN350
DN13	PN350
DN20	PN175
DN25	PN150
DN32	PN100
DN40	PN100
DN50	PN100

SEATS GEMPTFE O-RING NBR (KB)

DN6	PN350
DN10	PN350
DN13	PN350
DN20	PN175
DN25	PN150
DN32	PN100
DN40	PN100
DN50	PN100

Diagramma pressione temperatura

Pressure-temperature chart

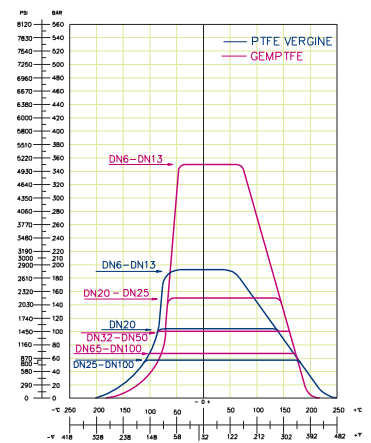
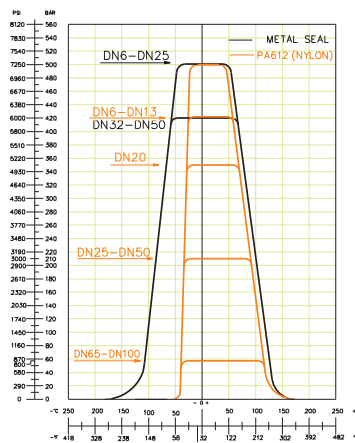
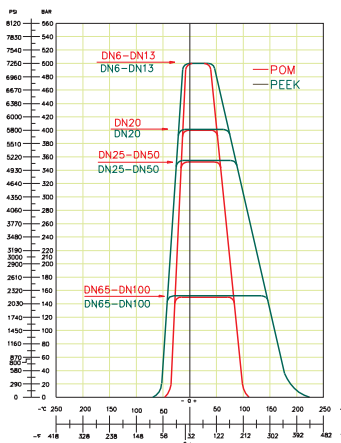

NOTA: I valori espressi nella tabella sono indicativi. Ad ogni tipo di valvola deve essere abbinato il rating di temperatura e pressione in rapporto alla dimensione del foro di passaggio fluido e al materiale del corpo, sfera, stelo. Le valvole a sfera in acciaio al carbonio sono adatte per basse temperature sino a -20°C , quelle in acciaio inox (316L) sino a -40°C . Per applicazioni al di sotto di queste temperature è necessario impiegare altri materiali.

NOTES: The values reported in the chart are just guidelines and should not be taken as compulsory. Every valve should be associated with the pressure/temperature rating in accordance with the dimension of the bore, the body material, the ball and the stem. Carbon steel valves are suitable for low temperature until -20°C while the stainless steel ones (316L) are suitable until -40°C . For any other use of the valves below these temperatures we suggest to employ a different material.

+ TECH TECHNICAL SHEETS

www.gemels.it

Calcolo del flusso per i liquidi

Il coefficiente di flusso (CV) è una formula utilizzata per determinare il flusso di una valvola sotto diverse condizioni. Il CV è così utile per selezionare la corretta valvola per ogni applicazione. Per il liquido il CV esprime il flusso in galloni per minuto di acqua a 60°F (15.6°C) con una caduta di pressione attraverso la valvola di 1 psi. Siccome i gas sono fluidi comprimibili, la formula viene alterata per rispondere ai cambiamenti di densità. Un singolo valore di CV è inserito per ogni valvola e rappresenta il valore del CV in posizione di piena apertura.

Liquids flow calculation

The coefficient of flow (CV) is a formula which is used to determine a valve's flows under various conditions and is thus useful for selecting the correct valve for a flow application. For liquids, CV expresses the flow in gallons for minute of 60°F (15.6°C) water with a pressure drop across the valve of 1 psi. because gases are compressible fluids, the formula is altered to accommodate changes in density. Valve specification list a single CV value for each valve model which represent the CV value at full open.

Coefficiente di portata

Capacity coefficient

TEST WITH WATER AT 20°C		
DN FB	CV (G.P.M.)	KV (m³/h)
6	5	4.27
10	7	6
13	35	30.2
20	61	53.7
25	105	90.66
32	210	176.5
40	285	245.2
50	425	364.52
65	750	645.4
80	1038	889.5
100	NR	NR

G.P.M. Gallons for minute

Determinazione diametri nominali

Determination of the nominal diameter

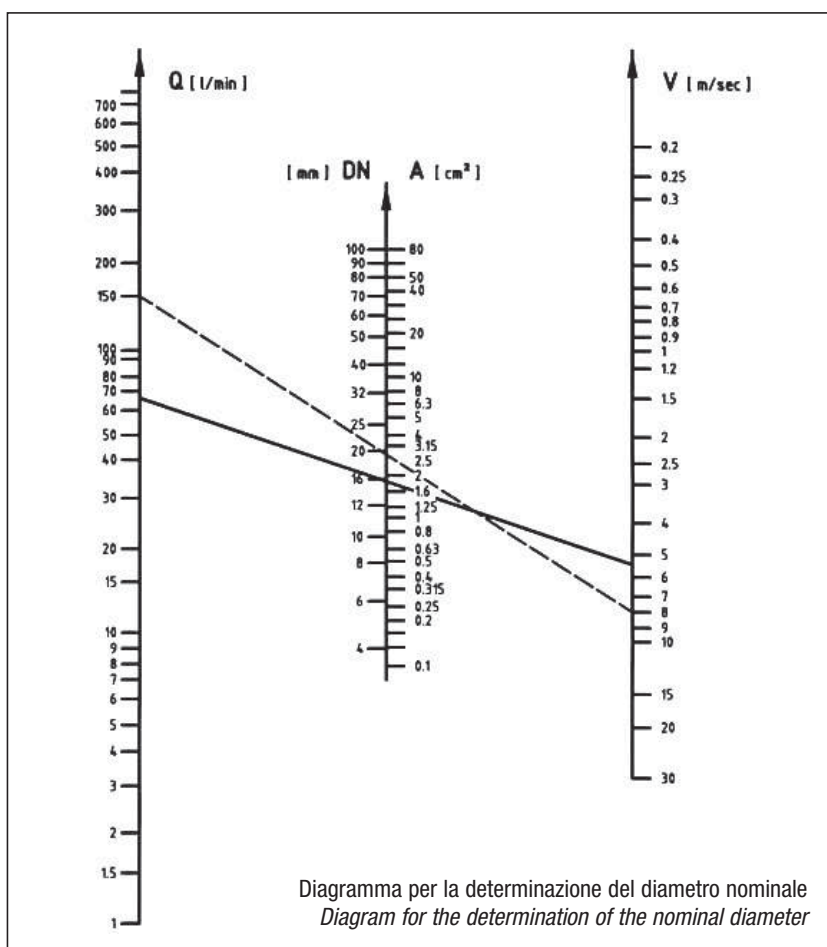

Suggeriamo l'utilizzo del seguente livello d'olio come linea guida:

Tubi d'aspirazione:	0.5...0.8 m/sec
Tubi di ritorno:	2...4 m/sec
Pressione tubi superiore a 10MPa:	2...4 m/sec
Pressione tubi superiore a 50MPa:	3...12 m/sec

Questo diagramma costituisce una guida per determinare il diametro nominale (DN)

ESEMPIO 1:

alla velocità $V = 8\text{ m/sec}$
e alla portata di $Q = 150\text{ l/min}$ scelta collegando sulle scale laterali i due valori si può ottenere sulla scala centrale la dimensione del diametro nominale equivalente (come es. DN20)

We recommend to use the following oil rate as guide line:

Suction pipes:	0.5 ... 0.8 m/sec
Return pipes:	2 ... 4 m/sec
Pressure pipes up to 10 MPa:	2 ... 4 m/sec
Pressure pipes up to 50 MPa:	3 ... 12 m/sec

This diagram provides a guide for the determination of the nominal diameter (DN)

EXAMPLE 1:

A velocity $v = 8\text{ m/sec}$
and a flow rate of $Q = 150\text{ l/min}$ have been selected. The straight line linking these two values on the outer scales intersects the nominal diameter DN20 on the middle scale.

+ TECH TECHNICAL SHEETS

www.gemels.it

Tabella di conversione °F/°C

Conversion table °F/°C

°C	°K	°F	°C	°K	°F	°C	°K	°F	°C	°K	°F	°C	°K	°F
-169	104,15	-272,2	4,4	277,55	39,92	182	455,15	359,6	360	633,15	680,0	538	811,15	1000,4
-168	105,15	-270,4	7,2	280,35	44,96	185	458,15	365,0	363	636,15	685,4	541	814,15	1005,8
-165	108,15	-265	10,0	283,15	50,00	188	461,15	370,4	366	639,15	690,8	543	816,15	1009,4
-162	111,15	-259,6	12,8	285,95	55,04	191	464,15	375,8	368	641,15	694,4	546	819,15	1014,8
-159	114,15	-254,2	15,6	288,75	60,08	193	466,15	379,4	371	644,15	699,8	549	822,15	1020,2
-157	116,15	-250,6	18,3	291,45	64,94	196	469,15	384,8	374	647,15	705,2	552	825,15	1025,6
-154	119,15	-245,2	21,1	294,25	69,98	199	472,15	390,2	377	650,15	710,6	554	827,15	1029,2
-151	122,15	-239,8	23,9	297,05	75,02	202	475,15	395,6	379	652,15	714,2	557	830,15	1034,6
-148	125,15	-234,4	26,7	299,85	80,06	204	477,15	399,2	382	655,15	719,6	560	833,15	1040,0
-146	127,15	-230,8	24,9	298,05	76,82	207	480,15	404,6	385	658,15	725,0	563	836,15	1045,4
-143	130,15	-225,4	32,2	305,35	89,96	210	483,15	410,0	388	661,15	730,4	566	839,15	1050,8
-140	133,15	-220,0	35,0	308,15	95,00	213	486,15	415,4	391	664,15	735,8	568	841,15	1054,4
-137	136,15	-214,6	37,8	310,95	100,04	216	489,15	420,8	393	666,15	739,4	571	844,15	1059,8
-134	139,15	-209,2	40,6	313,75	105,08	218	491,15	424,4	396	669,15	744,8	574	847,15	1065,2
-132	141,15	-205,6	43,3	316,45	109,94	221	494,15	429,8	399	672,15	750,2	577	850,15	1070,6
-129	144,15	-200,2	46,1	319,25	114,98	224	497,15	435,2	402	675,15	755,6	579	852,15	1074,2
-126	147,15	-194,8	48,9	322,05	120,02	227	500,15	440,6	404	677,15	759,2	582	855,15	1079,6
-123	150,15	-189,4	51,7	324,85	125,06	229	502,15	444,2	407	680,15	764,6	585	858,15	1085,0
-121	152,15	-185,8	54,4	327,55	129,92	232	505,15	449,6	410	683,15	770,0	588	861,15	1090,4
-118	155,15	-180,4	57,2	330,35	134,96	235	508,15	455,0	413	686,15	775,4	590	863,15	1094,0
-115	158,15	-175,0	60,0	333,15	140,00	238	511,15	460,4	416	689,15	780,8	593	866,15	1099,4
-112	161,15	-169,6	62,8	335,95	145,04	241	514,15	465,8	418	691,15	784,4	596	869,15	1104,8
-109	164,15	-164,2	65,6	338,75	150,08	243	516,15	469,4	421	694,15	789,8	599	872,15	1110,2
-107	166,15	-160,6	68,3	341,45	154,94	246	519,15	474,8	424	697,15	795,2	602	875,15	1115,6
-104	169,15	-155,2	71,1	344,25	159,98	249	522,15	480,2	427	700,15	800,6	604	877,15	1119,2
-101	172,15	-149,8	73,9	347,05	165,02	252	525,15	485,6	429	702,15	804,2	607	880,15	1124,6
-98,3	174,85	-144,94	76,7	349,85	170,06	254	527,15	489,2	432	705,15	809,6	610	883,15	1130,0
-95,6	177,55	-140,08	79,4	352,55	174,92	257	530,15	494,6	435	708,15	815,0	613	886,15	1135,4
-92,8	180,35	-135,04	82,2	355,35	179,96	260	533,15	500,0	438	711,15	820,4	616	889,15	1140,8
-90,0	183,15	-130,00	85,0	358,15	185,00	266	539,15	510,8	441	714,15	825,8	618	891,15	1144,4
-87,2	185,95	-124,96	87,8	360,95	190,04	263	536,15	505,4	443	716,15	829,4	621	894,15	1149,8
-84,4	188,75	-119,92	90,6	363,75	195,08	268	541,15	514,4	446	719,15	834,8	624	897,15	1155,2
-81,6	191,55	-114,88	93,3	366,45	199,94	271	544,15	519,8	449	722,15	840,2	627	900,15	1160,6
-78,9	194,25	-110,02	96,1	369,25	204,98	274	547,15	525,2	452	725,15	845,6	629	902,15	1164,2
-76,1	197,05	-104,98	98,9	372,05	210,02	277	550,15	530,6	454	727,15	849,2	632	905,15	1169,6
-73,3	199,85	-99,94	102	375,15	215,6	279	552,15	534,2	457	730,15	854,6	635	908,15	1175,0
-70,6	202,55	-95,08	104	377,15	219,2	282	555,15	539,6	460	733,15	860,0	638	911,15	1180,4
-67,8	205,35	-90,04	107	380,15	224,6	285	558,15	545,0	463	736,15	865,4	641	914,15	1185,8
-65,0	208,15	-85,00	110	383,15	230,0	288	561,15	550,4	466	739,15	870,8	643	916,15	1189,4
-62,2	210,95	-79,96	113	386,15	235,4	291	564,15	555,8	468	741,15	874,4	646	919,15	1194,8
-59,4	213,75	-74,92	115	388,15	239,0	293	566,15	559,4	471	744,15	879,8	649	922,15	1200,2
-56,7	216,45	-70,06	118	391,15	244,4	296	569,15	564,8	474	747,15	885,2	652	925,15	1205,6
-53,9	219,25	-65,02	121	394,15	249,8	299	572,15	570,2	477	750,15	890,6	654	927,15	1209,2
-51,1	222,05	-59,98	124	397,15	255,2	302	575,15	575,6	479	752,15	894,2	657	930,15	1214,6
-48,3	224,85	-54,94	127	400,15	260,6	304	577,15	579,2	482	755,15	899,6	660	933,15	1220,0
-45,6	227,55	-50,08	129	402,15	264,2	307	580,15	584,6	485	758,15	905,0	663	936,15	1225,4
-42,8	230,35	-45,04	132	405,15	269,6	310	583,15	590,0	488	761,15	910,4	666	939,15	1230,8
-40	233,15	-40,00	135	408,15	275,0	313	586,15	595,4	491	764,15	915,8	668	941,15	1234,4
-37,2	235,95	-34,96	138	411,15	280,4	316	589,15	600,8	493	766,15	919,4	671	944,15	1239,8
-34,4	238,75	-29,92	141	414,15	285,8	318	591,15	604,4	496	769,15	924,8	674	947,15	1245,2
-31,7	241,45	-25,06	143	416,15	289,4	321	594,15	609,8	499	772,15	930,2	677	950,15	1250,6
-28,9	244,25	-20,02	146	419,15	294,8	324	597,15	615,2	502	775,15	935,6	679	952,15	1254,2
-26,1	247,05	-14,98	149	422,15	300,2	327	600,15	620,6	504	777,15	939,2	682	955,15	1259,6
-23,3	249,85	-9,94	152	425,15	305,6	329	602,15	624,2	507	780,15	944,6	685	958,15	1265,0
-20,6	252,55	-5,08	154	427,15	309,2	332	605,15	629,6	510	783,15	950,0	688	961,15	1270,4
-17,8	255,35	-0,04	157	430,15	314,6	335	608,15	635,0	513	786,15	955,4	691	964,15	1275,8
-15,0	258,15	5,00	160	433,15	320,0	338	611,15	640,4	516	789,15	960,8	693	966,15	1279,4
-12,2	260,95	10,04	163	436,15	325,4	341	614,15	645,8	518	791,15	964,4	696	969,15	1284,8
-9,4	263,75	15,08	166	439,15	330,8	343	616,15	649,4	521	794,15	969,8	699	972,15	1290,2
-6,7	266,45	19,94	168	441,15	334,4	346	619,15	654,8	524	797,15	975,2	702	975,15	1295,6
-3,9	269,25	24,98	171	444,15	339,8	349	622,15	660,2	527	800,15	980,6			
-1,1	272,05	30,02	174	447,15	345,2	352	625,15	665,6	529	802,15	984,2			
0	273,15	32,00	177	450,15	350,6	354	627,15	669,2	532	805,15	989,6			
1,7	274,85	35,06	179	452,15	354,2	357	630,15	674,6	535	808,15	995,0			

General formula:
 The central column represents the temperature in °C or in °F.
 The equivalent temperature in °C or in °F is in the right or left column.

Momenti torcenti

Torque moment

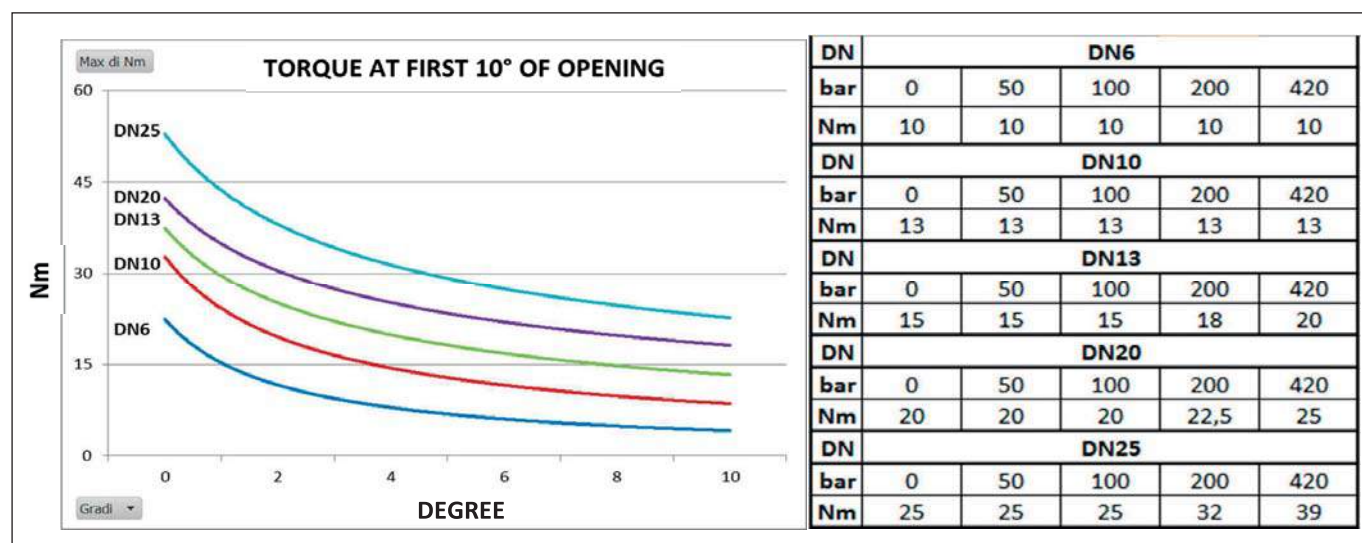
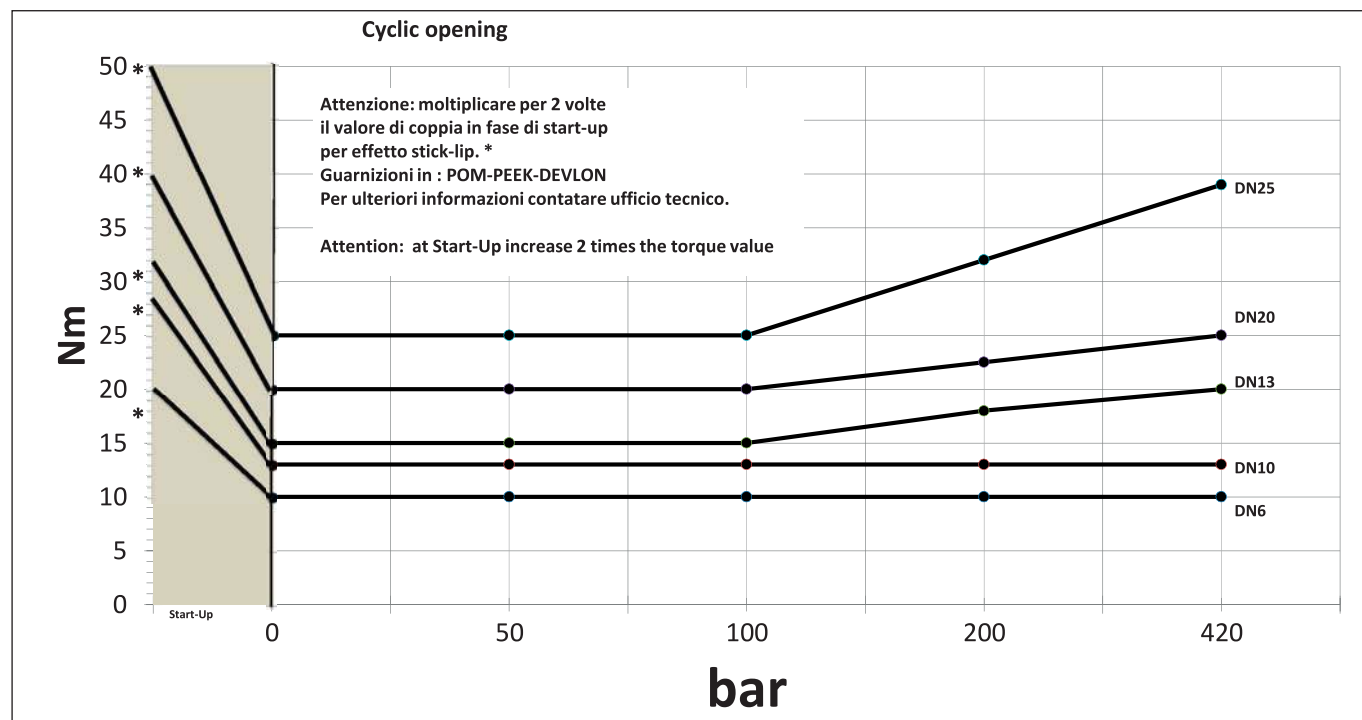

+ TECH TECHNICAL SHEETS

www.gemels.it

Tabella di conversione simboli

La tabella mostra aggiornamenti e valori risultati dai test alle valvole in situazioni standard. Temperatura 18 gradi - fluido acqua emulsionata. Gli aggiornamenti si riferiscono al momento di torsione delle valvole.

Pressioni e tempi sono i seguenti:

0 ore senza pressione (fire test)

0 ore (secondo test)

2 ore in pressione (terzo test)

48 ore in pressione (quarto test).

Weights and measures				
Symbol	When you Know	Multiply by	To Find	Symbol
LENGHT				
in	inches	2.5	centimeters	cm
ft	feet	30.0	centimeters	cm
yd	yards	0.9	meters	m
mi	miles	1.6	kilometers	km
AREA				
in ²	square inches	6.5	square centimeters	cm ²
ft ²	square feet	0.09	square centimeters	cm ²
yd ²	square yards	0.8	square meters	m ²
mi ²	square miles	2.6	square kilometers	km ²
	acres	0.4	hectares	ha
MASS				
oz	ounces	28	grams	g
lb	pounds	0.45	kilograms	kg
	short tons (2000 lb)	0.9	metric ton	t
VOLUME				
tsp	teaspoons	5	milliliters	mL
Tbsp	tablespoons	15	milliliters	mL
in ³	cubic inches	16	milliliters	mL
fl oz	fluid ounces	30	milliliters	mL
c	cups	0.24	liters	L
pt	pints	0.47	liters	L
qt	quarts	0.95	liters	L
gal	gallons	3.8	liters	L
ft ³	cubic feet	0.003	cubic meters	m ³
yd ³	cubic yards	0.76	cubic meters	m ³
TEMPERATURE (exact)				
F	Farenheit Degrees	subtract 32, multiply by 5/9	Celsius Degrees	C

Symbol conversion table

The charts show updates and values rendered during the valves test in standard situations. Temperature 18 degrees - fluid water with emulsion. The updates refers to the twirling moment of the valves.

Pressure and time are the followings:

0 hours without pressure (fire test)

0 hours (second test)

2 hours in pressure (third test)

48 hours in pressure (fourth test).

Approximate conversions from metric measures				
Symbol	When you Know	Multiply by	To Find	Symbol
LENGTH				
mm	millimeters	0.004	inches	in
cm	centimeters	0.4	inches	in
m	meters	3.3	feet	ft
m	meters	1.1	yards	yd
km	kilometers	0.6	miles	mi
AREA				
cm ²	square centimeters	0.16	square inches	in ²
m ²	square meters	1.2	square yards	yd ²
km ²	square kilometers	0.4	square miles	mi ²
ha	hectares (10,000 m ²)	2.5	acres	
MASS				
g	grams	0.035	ounces	oz
kg	kilograms	2.2	pounds	lb
t	metric ton (1,000 kg)	1.1	short tons	
VOLUME				
mL	milliliters	0.03	fluid ounces	fl oz
mL	milliliters	0.06	cubic inches	in ³
L	liters	2.1	pints	pt
L	liters	1.06	quarts	qt
L	liters	0.26	gallons	gal
m ³	cubic meters	35.0	cubic feet	ft ³
m ³	cubic meters	1.3	cubic yards	yd ³
TEMPERATURE (exact)				
C	Celsius Degrees	multiply by 5/9, add 32	Farenheit Degrees	F

Approximate liquid and dry measure equivalencies			
CUSTOMARY	METRIC	CUSTOMARY	METRIC
1/4 teaspoon	1.25 milliliters	1 cup	240 milliliters
1/2 teaspoon	2.5 milliliters	1 pint (2 cups)	480 milliliters
1 teaspoon	5 milliliters	1 quart (4 cups)	960 milliliters (0.96 liters)
1 tablespoon	15 milliliters	1 gallon (4 quarts)	3.84 liters
1 fluid ounce	30 milliliters	1 ounce (by weight)	28 grams
1/4 cup	60 milliliters	1/4 pound (4 ounces)	114 grams
1/3 cup	80 milliliters	1 pound (16 ounces)	454 grams
1/2 cup	120 milliliters	2.2 pounds	1 Kilogram (1,000 grams)

Workbook features Maintenance, conservation, removal and instructions for use

INTRODUCTION

GEMELS produces a broad range of ball valves to meet a huge variety of applications. The painstaking selection of the materials used, together with accurate valve assembly and testing, make each valve specific to a given use, without the need for further intervention or maintenance. We recommend contacting Gemels direct in the event of malfunctions or incorrect use of the valves: Gemels undertakes to replace any damaged parts and then carry out the acceptance tests. Gemels cannot be held liable for any losses due to valves repaired by third parties.

GEMELS VALVE CHARACTERISTICS

Gemels valves are built in accordance with the following standards and specifications:

BS 5351 ASME B16.34	regarding the dimensions
ASTM	regarding the materials
API 598-B16.34-API 602	regarding testing
FIAT AUTO 9.57405	regarding material protection
ATEX 94/9/CE	

ACCEPTABLE FLUIDS

Gemels valves are used in plant containing fluids belonging to Group 2 of article 9 of European Directive 97/23 EC PED. Valves can, however, be built to withstand easily flammable fluids (gas, petrol, oil) and corrosive fluids (paints) belonging to Group 1 of the same Directive when specifically requested, but only once the Customer has provided Gemels with full details of its needs. Valves installed in corrosive environments or that handle corrosive fluids must be controlled at regular intervals of 12 months to check the thickness of the body and plug. Once the thickness drops to the minimum thickness allowed under the relevant standards, the valve must be replaced. Gemels cannot be held liable for any damage to property or injury to people or animals as a result of improper use of the product.

WORKING TEMPERATURE

Gemels standard valves are used at allowed temperatures in accordance with material, but for applications outside the field showed in the table, please contact Gemels s.r.l. The materials subjected to unbearable temperatures than their own specific qualities can cause irreparable damages!

PERMISSIBLE MINIMUM AND MAXIMUM VALUES OF GEMELS VALVES

MATERIAL	* CODE GEMELS	TEMPERATURE
11SmPb37	1	-10°C +100°C
A105 ASTM A105	2	20°C +100°C
LF2 ASTM A350	L	-40°C +100°C
316L ASTM A182	4	-60°C +230°C

VALVES	PRESSION	FLUIDS
GE GP GK GH GRDN6 DN13	500 BAR	GROUP2
GE GP GK GH GRDN20 DN25	350 BAR	GROUP2
GB GP GK GH GR DN32 DN50	350 BAR	GROUP2
GN DM DN6 DN100	150 BAR	GROUP1
GN GM DN6 DN50	500 BAR	GROUP2
GV	500 BAR	GROUP2

+ TECH TECHNICAL SHEETS

www.gemels.it

*Workbook features
Maintenance, conservation, removal and instructions for use*

MATERIALS USED

Standard valves (type GE- GP GK GH) are made from high-speed materials, such as 11SMnPb37 (avp), working at room temperature; materials like A105-LF2-AISI 303-304-316 that can withstand even higher temperatures are used for valves type GB-GM GR GV and special valves.

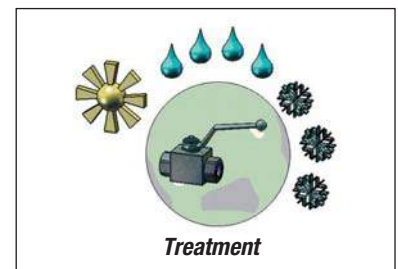
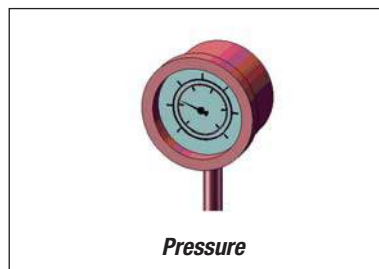
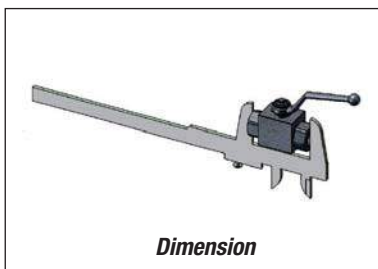
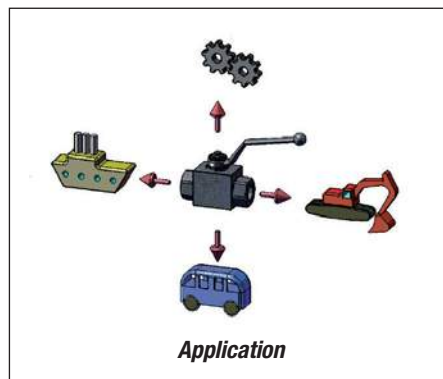

BEST SOLUTION

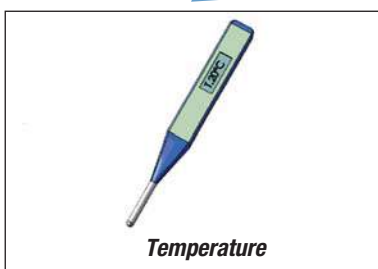

Workbook features Maintenance, conservation, removal and instructions for use

INSTALLATION AND USE *Ball valves with threaded ends are installed on the line in the following way.*



- Make sure you remove the protection at the ends (this protection should only be removed at the very last minute before installation, as they prevent foreign bodies entering the valve). Check that the threading on the fitting is clean and not damaged in any way.
- When tightening on the pipe, never hold the valve by the open/close lever, but use a wrench on the plug hexagon.

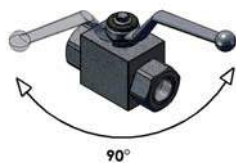

- The valves can be installed in any position: at an angle, vertical or horizontal. They can be operated by hand or using an actuator.
- Turn the open/close lever by 90° until it reaches its limit stop to open or close the valve by hand.

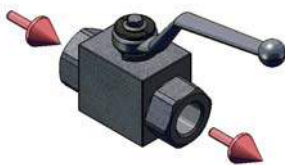

- The valve is OPEN when the lever is longitudinal (parallel to the line).



- The valve is CLOSED when the lever is perpendicular (at right-angles to the line).

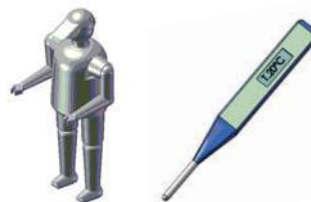

Never use these valves as pressure regulators! Installers: All personnel responsible for fitting the valves must have all the necessary professional qualifications and training and, in addition, must read the user and safety manuals beforehand. They must make sure:

- Never to install the valves on lines that work at temperatures below or above the allowed limits.
- Never use thread locking permanent on the ends of the valves during installation, as these will immediately inhibit all the valve functions. Gemels recommend thread sealant for all valves.



- Never use the valves without authorisation in plant handling the so-called "harmful" fluids (i.e. not specified in the above standards).



- Never attempt to assemble or change the valves when the line is pressurised.



- Never exceed the max working pressure indicated on the valves.

Workbook features Maintenance, conservation, removal and instructions for use

CONSERVATION

The valves are delivered in a packing that, if are not used in a short time, must be stocked in a cool place and lifted from the ground. In case this is not possible, check periodically the valves both in the leakage points (attachment stem) and in all the painted surface where a beginning of corrosion could begin because of environmental factors. **Protect each six months with a light layer of protective oil the ball valves.**

DEVICES NECESSARY FOR CONSERVATION

The goal of the workbook is that of helping the user in conservation and intact maintenance of Gemels products.

All the valves of this workbook are covered with suited galvanic treatments so they do not need possible covers or protective treatments for their conservation. In spite of all that GEMELS recommends to take some simple devices for long storage stops.

- 1) Ensure that the material is in a cool place and far from sources of heat.
- 2) Keep it off from direct sunlight and continue sources of heat.
- 3) Do not stock the valves in places with a high concentration of abrasive dusts.
- 4) Ensure that the protective plastic plugs are not being taken off.

In case of contact with water or humidity dry and possibly oil the interested parts.

According to our salt mist accelerated corrosion tests in accordance with ASTM B 117, concerning some samples of valves in carbon steel with a cycle of galvanisation and passivation we can state as follows:

50 exposure hours	no corrosion point
100 exposure hours	2-3 white oxyde points
150 exposure hours	3-4 red oxyde points

NB. For the points 1,2,3,5 in case of impossibility to respect such devices, the damage caused will be limited and at external esthetique surface, and in any case it would not cause technical damages or would damage the functioning of the valve itself.

For any damages or particular valve storage exposures Gemels can be contacted in order to show you the best appropriate solution to your case.

REMOVAL

At the end of their lifetime the valves have to be removed, in accordance with legislation in force about industrial waste removal.

All the components of the valve can be recycled, but the seals even if they are not toxic and noxious.



Gemels cannot be considered responsible in any case for accidents or damages caused by the incorrect use of the valves and of their features, by non authorized personnel, not appropriately educated, by non-observance even partial of the rules and procedures operation containing in the workbook.

These instructions must accompany the product to which they refer.



Workbook features Maintenance, conservation, removal and instructions for use

VALVE MARKING

The valves must be marked in accordance with design rules helping the fitter to have more information.

For the materials the marking must be done in accordance with GEMELS internal code that I represent as follows:

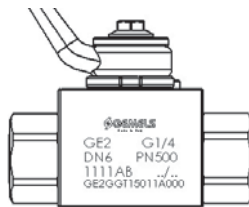

STANDARD PRINT

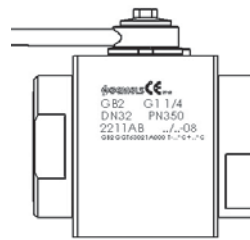

CE STANDARD PRINT

MARKING DETAIL

GE2 = TYPE OF VALVE
G1/4 = END
O/Z = HEAT
DN6 = Ø INTERNAL
PN500 = PRESSURE
1111AB = MATERIAL
L/D = DATE

1111AB DETAIL

1 = BODY MATERIAL
1 = ADAPTER MATERIAL
1 = BALL MATERIAL
1 = STEM MATERIAL
A = SEALS MATERIAL
B = O-RING MATERIAL

CLASSIFICATION MATERIAL

1 = 1,0737 - FE37
2 = A105 - FE42
3 = AISI 303
4 = 316L
5 = AISI420
6 = AISI304
L = LF2
K = GEMPTFE
I = KARLEZ
L = MVQ(SILICON)
M = METAL TO METAL

CLASSIFICATION SEAL MATERIAL

A = POM
B = NBR
C = PTFE
D = PEEK
E = FKM
F = EPDM
G = PA612