

TUBI TERMOPLASTICI
SETTORE LUBRIFICAZIONE E
SISTEMI DI MISURAZIONE
ZEC



 HYDRAULIC
COMPONENTS
& FLUID CONTAMINATION
CONTROL



All trademarks belong to their respective owners; third party trademarks, product names, trade names, corporate names and company names mentioned may be trademarks of their respective owners or registered trademarks of other companies and are used for instructional purposes and for the benefit of the owner, without any end of Copyright infringement in force.

Tutti i marchi riportati appartengono ai legittimi proprietari; marchi di terzi, nomi di prodotti, nomi commerciali, nomi corporativi e società citati possono essere di proprietà dei rispettivi titolari o registrati da altre società e sono stati utilizzati a puro scopo esplicativo e a beneficio del possessore, senza alcun fine di violazione dei diritti di Copyright vigenti.



SISTEMI DI LUBRIFICAZIONE E MISURAZIONE / LUBRICATION AND MEASURING SYSTEMS



Tubi termoplastici per la lubrificazione e sistemi di misurazione
*Thermoplastic Tubing and Hoses for Lubrication
and Measuring Systems*



THERMOPLASTIC TUBING AND HOSES





Indice / *Index*

Azienda / *Company*4

Soluzioni ZEC per sistemi di lubrificazione / *ZEC Solutions for Lubrication Systems* **6**



PA12 HL11



PA12 PHL12



PA12 PHL13



GR714



Boccole e raccordi per tubi serie GR7 / *Ferrules and Fittings for GR7 Series*15



Tubi per ingrassaggio e pistole ad ingrassaggio / *Greasing Hose Assemblies for Grease Guns*22

Soluzioni ZEC per sistemi di misurazione / *ZEC Solutions for Measuring Systems* **23**



TS7/TS7-PA26



TS8/TS8-PA27



Boccole e raccordi / *Ferrules and Fittings*28

Accessori / *Accessories* **46**

Spirali di protezione GS / *GS Protection Spirals*46

Guaine Tessili di protezione GT / *GT Textile Protection Sheaths*47

Pinze taglia tubo / *Tubing and Hose Cutter*47

Pressa manuali e pneumatiche / *Manual and Pneumatic Crimping Machines*48

Tappi di servizio / *Service Plugs*49

Indicazioni di montaggio / *Installation Instructions* **50**

ZEC S.p.A.: Flessibilità per scelta

ZEC S.p.A., fondata nel 1961 da Eugenio Zantelli a Colorno, in provincia di Parma, produce tubi termoplastici per applicazioni a bassa, media, alta e altissima pressione.

A partire dal 1990 le attività commerciali sul mercato domestico sono estese all'espansione sui mercati internazionali.

Investimenti in risorse umane particolarmente qualificate, impianti di produzione tecnologicamente avanzati, attività di ricerca e sviluppo e la presenza commerciale favoriscono l'espansione sui mercati globali, dove ZEC S.p.A. oggi è presente in più di 90 paesi.

La considerevole crescita in tutte le aree è stata accompagnata da una gamma di prodotti sempre più ampia, dedicata a numerosi settori applicativi, quali oleodinamica, pneumatica, lubrificazione, automotive, alimentare, navale, refrigerazione, petrochimico-offshore, etc..

La gamma di prodotti di ZEC S.p.A. comprende tubi termoplastici standard o customizzati singoli, multipli e spiraliati, con caratteristiche tecniche da 2mm a 40mm di diametro interno, pressioni di lavoro da 5bar a 1280bar e temperature di esercizio da -200°C a +260°C.

Tutti i tubi termoplastici di ZEC S.p.A. sono prodotti di materie prime di primaria qualità accuratamente selezionate. Ogni fase del ciclo produttivo è soggetta a severi controlli qualitativi.

La produzione avviene esclusivamente all'interno dei ns. stabilimenti a Colorno, Italia.

I prodotti finiti sono conformi alle principali normative internazionali dei rispettivi settori applicativi, quali SAE, EN, ISO e DIN.

ZEC S.p.A. opera in regime di qualità UNI EN ISO 9001-2015.

ZEC S.p.A.: Flexibility for Choice

ZEC S.p.A., founded in 1961 by Mr. Eugenio Zantelli in Colorno, Province of Parma, Italy, manufactures thermoplastic tubing and hoses for low, medium, high and very high pressure applications.

Domestic business activities are boosted by an International breakthrough as of 1990.

Investments in special skilled human resources, manufacturing, product innovations and commercial presence elevates ZEC S.p.A. meanwhile into the global market, covering more than 90 countries world-wide.

Significant growth in all areas have been accompanied with an ever increasing product range dedicated to a large portfolio of applications such as fluid power, pneumatics, lubrication, automotive, food processing, marine, refrigeration, petrochemical-offshore, and so on.

The ZEC S.p.A. product range includes standard or customized single, multiple and coiled thermoplastic tubing and hoses, with technical characteristics within the range of 2mm to 40mm inner diameter, working pressures from 5bar to 1280bar and operating temperatures from -200°C to +260°C.

All products manufactured by ZEC S.p.A. are of top quality and carefully selected raw materials. Manufacturing processes are continuously multiple controlled.

The entire production takes place in our facilities located in Colorno, Italy.

End products comply strictly with major international standards such as SAE, EN, DIN & ISO.

All company sectors and activities are qualified and operate according to UNI EN ISO 9001-2015 quality system.

Lubrication and Measuring Systems

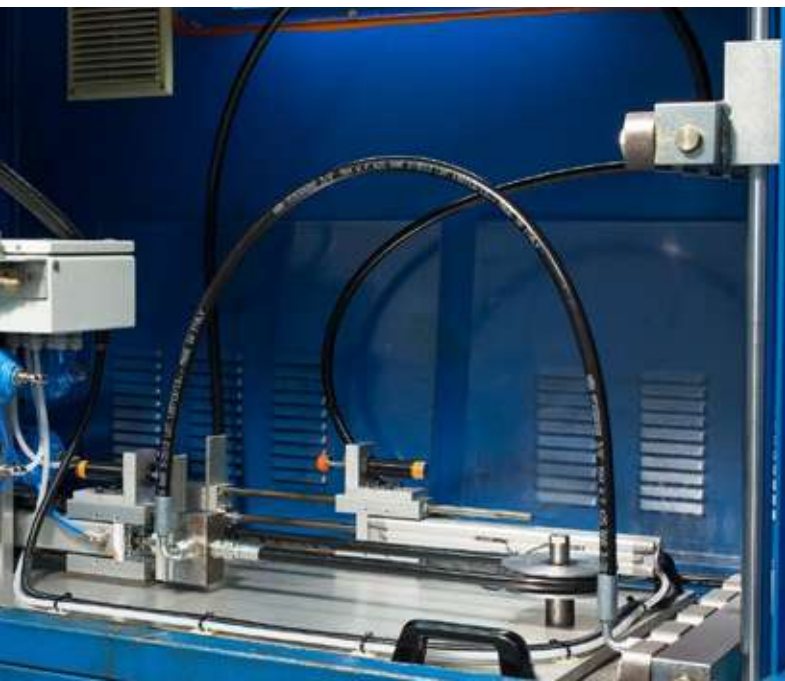

Le soluzioni ZEC per sistemi di lubrificazione

ZEC offre una gamma dedicata di tubi termoplastici progettati per il trasporto sia ad alta che a bassa pressione di lubrificanti e grasso. Vengono utilizzati in un'ampia varietà di mercati, come l'industria manifatturiera, i veicoli industriali, i macchinari minerari, agricoli e da costruzione, per citarne solo alcuni.

Questa gamma di tubi è progettata per resistere a condizioni ambientali difficili.

CARATTERISTICHE TECNICHE

- Compattezza
- Leggerezza
- Elevata flessibilità
- Resistenza al Kinking

APPLICAZIONI



SISTEMI DI INGRASSAGGIO
E LUBRIFICAZIONE
CENTRALIZZATI



ATTREZZATURA PORTATILE
PER LA DISTRIBUZIONE DI
GRASSO

NORMATIVE E CERTIFICAZIONI

I tubi ZEC per la lubrificazione sono conformi alla normativa DIN 1283 e sono certificati MSHA*. Tutti i tubi ZEC sono prodotti in conformità al **Regolamento Europeo CE 1907/2006 "REACH"** e alla **Direttiva Europea UE 65/2011 "RoHS"**.

*solo copertura PU waterproof.

QUALITÀ

Il sistema di qualità certificato **ISO 9001:2015 ZEC** assicura un controllo continuo e costante del processo produttivo, garantendo il rispetto delle buone pratiche di fabbricazione.





ZEC Solutions for Lubrication Systems

ZEC offers a dedicated range of thermoplastic hoses and tubing designed for both high and low pressure conveying of lubricants and grease. They are used in a huge variety of markets, such as manufacturing industry, industrial vehicles, mining, agricultural and construction machinery, to mention only a few.

They are designed to resist against harsh environmental conditions.

TECHNICAL FEATURES

- Compact
- Lightweight
- Extremely flexible
- Kinking resistant

APPLICATIONS



CENTRAL GREASING AND LUBRICATION SYSTEMS



HANDHELD GREASE DISTRIBUTION EQUIPMENT

STANDARDS AND CERTIFICATIONS

ZEC Lubrication hoses are compliant with DIN 1283 and are MSHA certified*. All ZEC hoses are manufactured in conformity and comply to **European Regulation EC 1907/2006 "REACH"** and **European Directive 65/2011 "RoHS"**.

*only PU waterproof cover.

QUALITY

The certified **ISO 9001:2015 ZEC** quality system ensures a continuous and constant control of the production process, guaranteeing compliance with Good Manufacturing Practices.



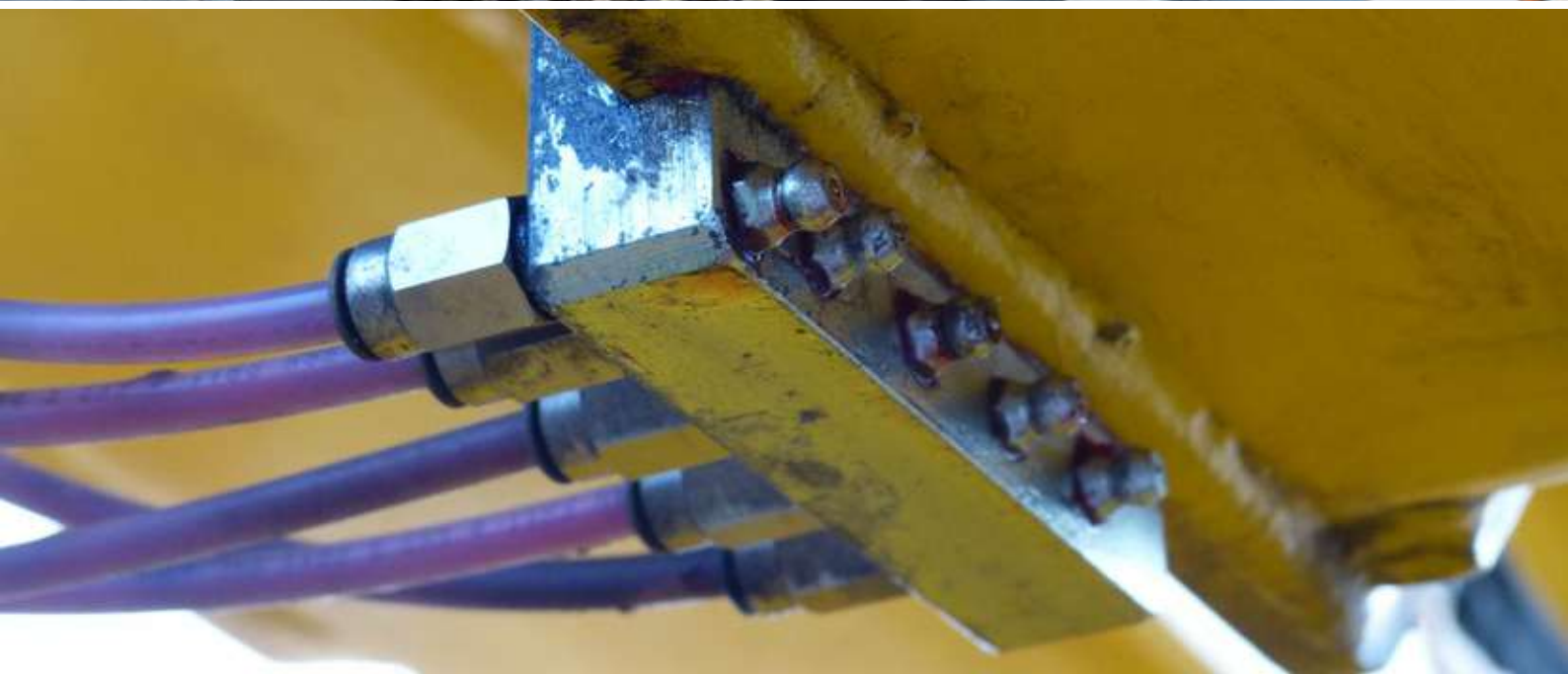
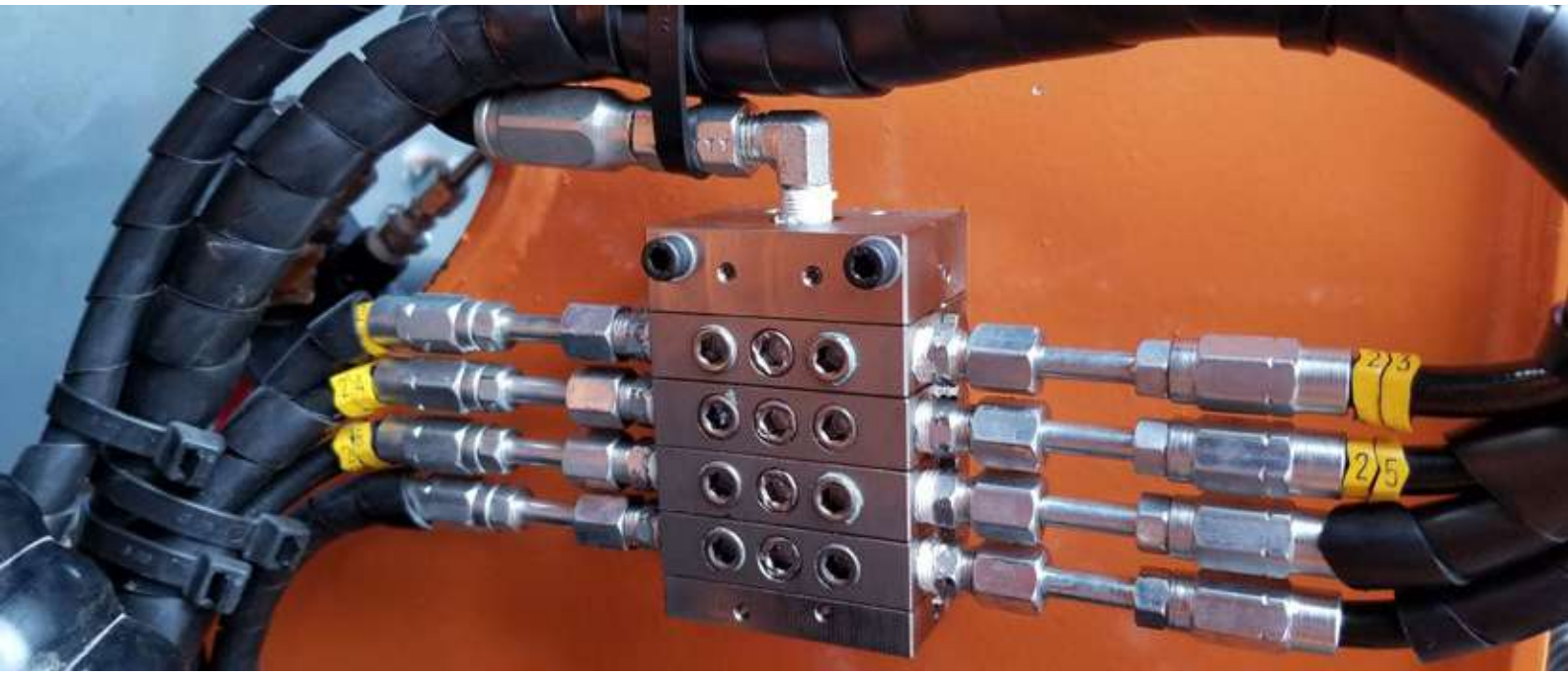

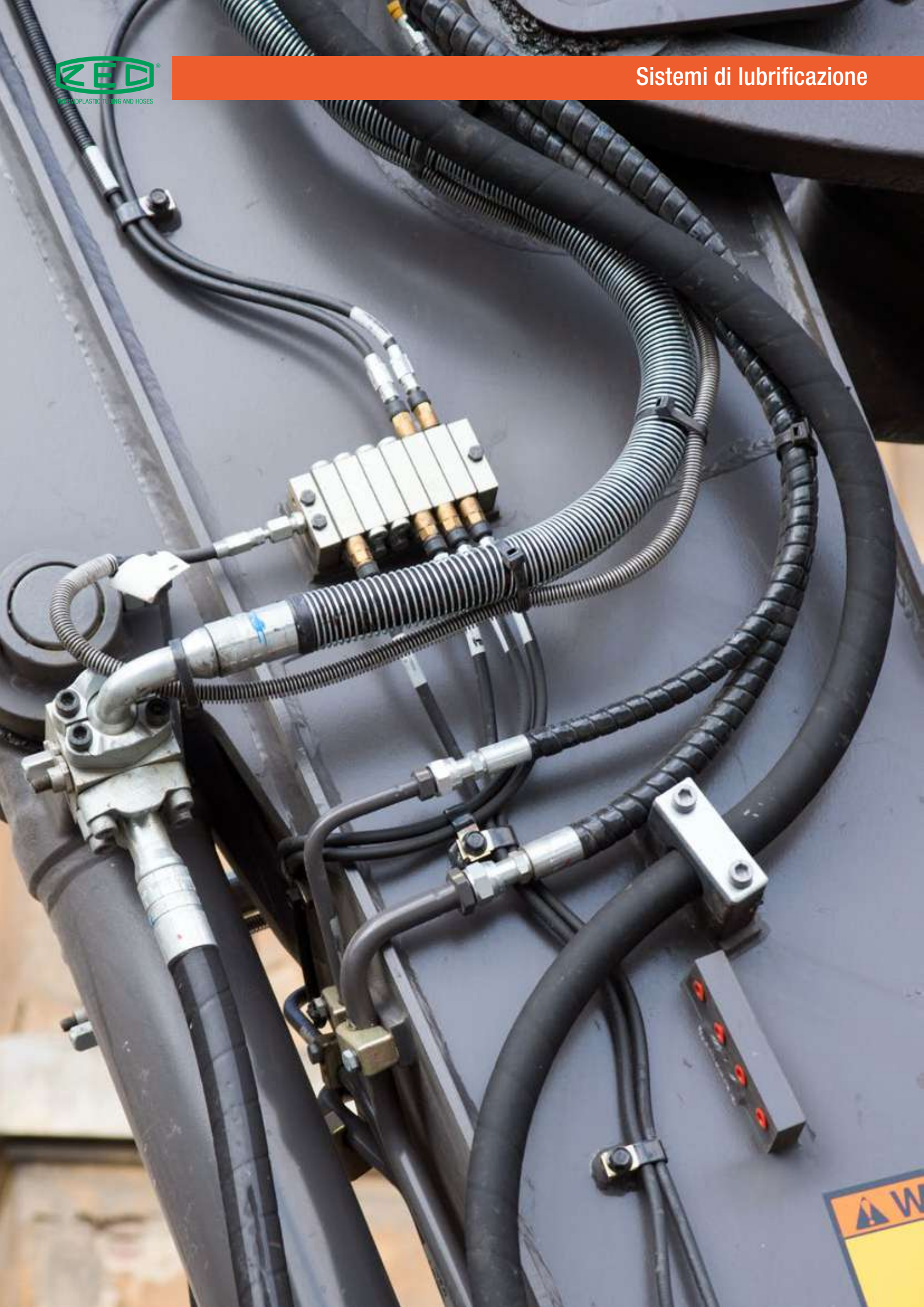

PA12 HL

TUBO DI POLIAMMIDE

POLYAMIDE TUBING



Caratteristiche principali

- Normativa DIN 74324 e 73378
- Tubi bassa pressione di poliammide PA12 HL

Main Features

- DIN 74324 and 73378 standards
- Low pressure PA12 HL polyamide tubing

Caratteristiche tecniche

- **Temperature di esercizio:**
Da -40°C a +100°C (-40°F to +212°F).
Per fluidi a base acquosa temperatura di esercizio max. +70°C (158°F).
- **Picchi di temperatura:**
Max +125°C (+257°F). Se la durata o la frequenza dei picchi è rilevante, la durata di vita utile del tubo potrebbe essere ridotta.
- **Colore:**
Nero. Altri colori disponibili su richiesta.
- **Specifiche:**
Normative DIN 74324 e 73378 (* Solo DIN 73378).

Technical Features

- **Working Temperatures:**
From -40°C to +100°C (-40°F to +212°F).
Max. working temperature with water-based fluids +70°C (158°F).
- **Temperature Peaks:**
Max +125°C (+257°F). If the duration or frequency of the peaks is significant, the hose lifespan may be reduced.
- **Colour:**
Black. Other colours available on request.
- **Specifications:**
DIN 74324 and 73378 standards (* DIN 73378 only).

Coefficiente di correzione della pressione di scoppio in funzione della temperatura

Pressure correction factor as function of temperature

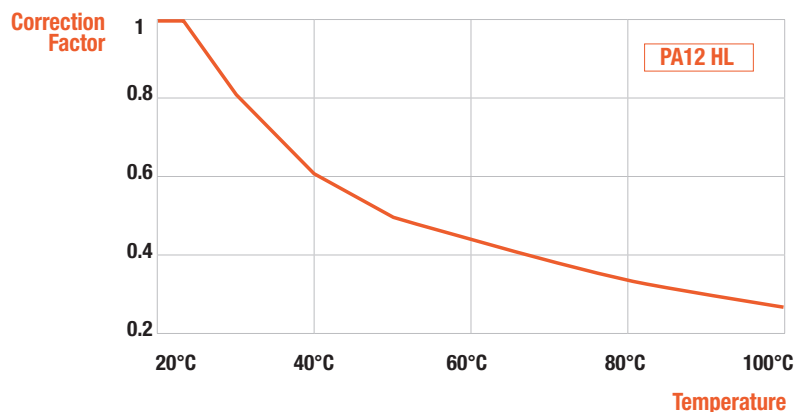

Scheda tecnica - Data Sheet



CODE	mm	inch	mm	inch	mm	inch	bar	psi	bar	psi	mm	inch	g/m	lbs/ft
TA42NSR	2.0	0.079	4.0	0.157	1.0	0.039	91	1319	273	3959	25	0.984	9.5	0.0064
TA425NSR*	2.5	0.098	4.0	0.157	0.75	0.030	63	913	189	2741	36	1.417	7.7	0.0052
TA63NSR*	3.0	0.118	6.0	0.236	1.5	0.059	93	1348	279	4046	36	1.417	21.4	0.0144
TA64NSR	4.0	0.157	6.0	0.236	1.0	0.039	56	812	168	2436	50	1.969	15.9	0.0107
TA86NSR	6.0	0.236	8.0	0.315	1.0	0.039	40	580	120	1740	102	4.016	22.2	0.0149
TA108NSR	8.0	0.315	10.0	0.393	1.0	0.039	31	449	93	1348	225	8.858	28.5	0.0192

PA12 PHL Y

TUBO DI POLIAMMIDE

POLYAMIDE TUBING



Caratteristiche principali

- Normativa DIN 74324 e 73378
- Tubi bassa pressione di poliammide PA12 PHL Y

Main Features

- DIN 74324 and 73378 standards
- Low pressure PA12 PHL Y polyamide tubing

Caratteristiche tecniche

- **Temperature di esercizio:**
Da -40°C a +80°C (-40°F to +176°F).
Per fluidi a base acquosa temperatura di esercizio max. +70°C (158°F).
- **Picchi di temperatura:**
Max +100°C (+212°F). Se la durata o la frequenza dei picchi è rilevante, la durata di vita utile del tubo potrebbe essere ridotta.
- **Colore:**
Nero. Altri colori disponibili su richiesta.
- **Specifiche:**
Normative DIN 74324 e 73378 (* Solo DIN 73378).

Technical Features

- **Working Temperatures:**
From -40°C to +80°C (-40°F to +176°F).
Max. working temperature with water-based fluids +70°C (158°F).
- **Temperature Peaks:**
Max +100°C (212°F). If the duration or frequency of the peaks is significant, the hose lifespan may be reduced.
- **Colour:**
Black. Other colours available on request.
- **Specifications:**
DIN 74324 and 73378 standards (* DIN 73378 only).

Coefficiente di correzione della pressione di scoppio in funzione della temperatura

Pressure correction factor as function of temperature

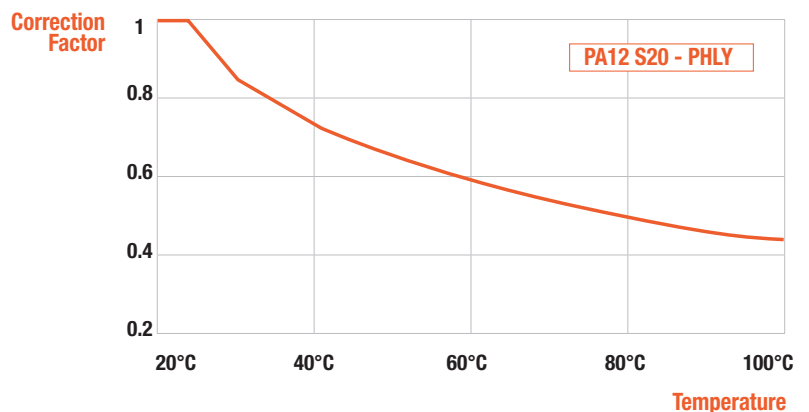

Scheda tecnica - Data Sheet



CODE	mm	inch	mm	inch	mm	inch	bar	psi	bar	psi	mm	inch	g/m	lbs/ft
TA42N20	2.0	0.079	4.0	0.157	1.0	0.039	67	971	201	2915	20	0.787	9.6	0.0065
TA425N20*	2.5	0.098	4.0	0.157	0.75	0.030	47	681	141	2045	30	1.181	7.8	0.0052
TA63N20*	3.0	0.118	6.0	0.236	1.5	0.059	68	986	204	2958	30	1.181	21.6	0.0145
TA64N20	4.0	0.157	6.0	0.236	1.0	0.039	41	594	123	1783	42	1.654	16.0	0.0108
TA86N20	6.0	0.236	8.0	0.315	1.0	0.039	27	391	81	1174	65	2.559	22.4	0.0151
TA108N20	8.0	0.315	10.0	0.393	1.0	0.039	23	333	69	1000	150	5.906	28.8	0.0194

PA12 PHL

TUBO DI POLIAMMIDE

POLYAMIDE TUBING



Caratteristiche principali

- Normativa DIN 74324 e 73378
- Tubi bassa pressione di poliammide PA12 PHL

Main Features

- DIN 74324 and 73378 standards
- Low pressure PA12 PHL polyamide tubing

Caratteristiche tecniche

- **Temperature di esercizio:**
Da -40°C a +80°C (-40°F to +176°F).
Per fluidi a base acquosa temperatura di esercizio max. +70°C (158°F).
- **Picchi di temperatura:**
Max +100°C (+212°F). Se la durata o la frequenza dei picchi è rilevante, la durata di vita utile del tubo potrebbe essere ridotta.
- **Colore:**
Nero. Altri colori disponibili su richiesta.
- **Specifiche:**
Normative DIN 74324 e 73378 (* Solo DIN 73378).

Technical Features

- **Working Temperatures:**
From -40°C to +80°C (-40°F to +176°F).
Max. working temperature with water-based fluids +70°C (158°F).
- **Temperature Peaks:**
Max +100°C (212°F). If the duration or frequency of the peaks is significant, the hose lifespan may be reduced.
- **Colour:**
Black. Other colours available on request.
- **Specifications:**
DIN 74324 and 73378 standards (* DIN 73378 only).

Coefficiente di correzione della pressione di scoppio in funzione della temperatura

Pressure correction factor as function of temperature

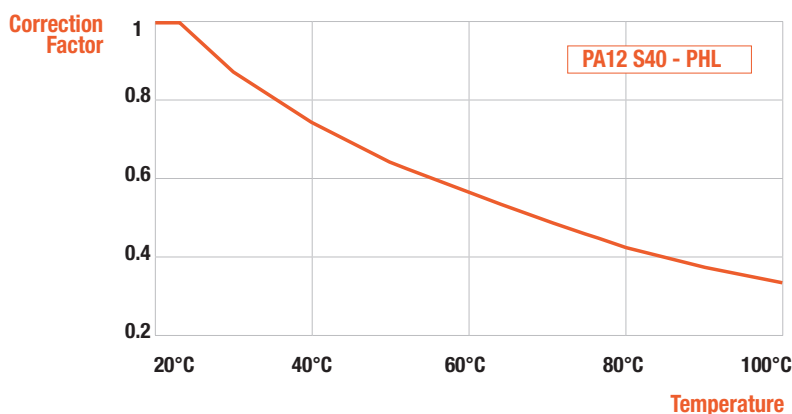

Scheda tecnica - Data Sheet



CODE	mm	inch	mm	inch	mm	inch	bar	psi	bar	psi	mm	inch	g/m	lbs/ft
TA42N40	2.0	0.079	4.0	0.157	1.0	0.039	44	638	132	1914	16	0.630	9.7	0.0065
TA425N40*	2.5	0.098	4.0	0.157	0.75	0.030	31	449	93	1348	24	0.945	7.9	0.0053
TA63N40*	3.0	0.118	6.0	0.236	1.5	0.059	44	638	132	1914	25	0.984	21.8	0.0146
TA64N40	4.0	0.157	6.0	0.236	1.0	0.039	28	406	84	1218	30	1.181	16.2	0.0109
TA86N40	6.0	0.236	8.0	0.315	1.0	0.039	20	290	60	870	40	1.575	22.6	0.0152
TA108N40	8.0	0.315	10.0	0.393	1.0	0.039	16	232	48	696	60	2.362	29.1	0.0196

GR7

PER SISTEMI DI LUBRIFICAZIONE FOR LUBRICATION SYSTEMS



Caratteristiche principali

- Peso ridotto e compattezza
- Elevata flessibilità
- Resistenza al kinking
- Elevata resistenza all'abrasione

Main Features

- Low weight and compactness
- High flexibility
- Kinking resistance
- High abrasion resistance

Caratteristiche tecniche

- **Caratteristiche tecnico-costruttive:**
Anima interna in poliestere (o poliammide *), rinforzo trecciato in fibra di poliestere e rivestimento esterno in poliuretano nero opaco. A richiesta rivestimento in poliuretano lucido.
Copertura autoestinguente disponibile su richiesta (UL94-V0).
- **Temperature di esercizio:**
Da -40°C (-40°F) a +80°C (+176°F).
In caso di acqua, o fluidi a base acquosa, la temperatura massima di lavoro è di +70°C (+158°F). Temperature superiori a +80°C possono ridurre la durata di vita utile del tubo.
- **Valore max. di vuoto:**
pressione assoluta 0.93bar; 700 mmHg.
(pressione assoluta 13.5 psi; 27.5 inchHg).
- **Variation max. di lunghezza alla pressione di esercizio:**
Da -1.5% a +1.5%
- **Specifiche:**
Tubi conformi agli standard MSHA.
Δ Tubi conformi o superiori alle pressioni della normativa DIN 1283.

Technical Features

- **Technical-constructive features:**
Inner core of polyester (or polyamide), braided reinforcement of polyester fiber and outer covering of matte black polyurethane. Shiny polyurethane cover available on request. Self-extinguishing cover available on request (UL94-V0).*
- **Working temperatures:**
*From -40°C (-40°F) to +80°C (+176°F).
Max. working temperature with water or water based fluids is +70°C (+158°F). Temperatures higher than +80°C may reduce hose lifespan.*
- **Max. vacuum value:**
*absolute pressure 0.93bar; 700 mmHg.
(absolute pressure 13.5 psi; 27.5 inchHg).*
- **Max. length variation at working pressure:**
From -1.5% to +1.5%
- **Specifications:**
*These hoses meet MSHA standard.
Δ These hoses meet or exceed pressures of DIN 1283 standard.*

Scheda tecnica - Data Sheet



CODE	mm	inch	DN	mm	inch	bar	psi	bar	psi	mm	inch	g/m	lbs/ft	FERRULE
GR7112000	3.5	1/8"	3	7.5	0.295	200	2900	800	11600	25	0.984	37	0.0249	BP180L5
GR710412000 ^Δ	4.0	0.157	4	10.0	0.394	400	5800	900	13050	35	1.378	75	0.0504	BP316R7
GR7108412000 ^Δ	4.0	0.157	4	10.8	0.425	400	5800	900	13050	35	1.378	97	0.0652	BP316R7
GR7840000**	4.0	0.157	4	8.0	0.315	200	2900	800	11600	30	1.181	45	0.0302	BP480L5
GR7712000	4.0	0.157	4	8.6	0.339	280	4060	840	12180	20	0.787	46	0.0309	BP532R7
GR7PA712000*	4.0	0.157	4	8.6	0.339	280	4060	840	12180	20	0.787	46	0.0309	BP532R7
GR7940000** ^Δ	4.0	0.157	4	9.1	0.358	250	3630	900	13050	40	1.575	60	0.0403	BP532R7
GR720000**	4.8	3/16"	5	9.2	0.362	200	2900	800	11600	30	1.181	59	0.0396	BP3160L5
GR7312000	6.3	0.248	6	11.3	0.445	280	4060	840	12180	35	1.378	84	0.0564	BP14R7
GR7PA312000*	6.3	0.248	6	11.3	0.445	280	4060	840	12180	20	0.787	84	0.0564	BP14R7

* Anima interna in PA. ** Rivestimento in PU lucido.

* PA inner core. ** Shiny PU cover.

BOCCOLE E RACCORDI PER TUBI SERIE GR7 / FERRULES AND FITTINGS FOR GR7 SERIES HOSES

BOCCOLA RECUPERABILE PER TUBO SERIE GR7
REUSABLE FERRULES FOR GR7 SERIES HOSES

**BR0L5
BRMT1**

Materiale <i>Material</i>	Acciaio AVP <i>Carbon Steel</i>
Finitura superficiale <i>Surface Finishing</i>	Zincatura trivalente <i>Zinc Plating</i>

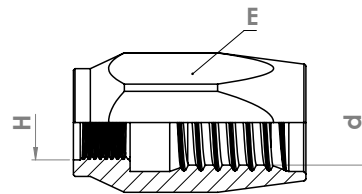

Codice <i>Part Number</i>	Diametro tubo <i>Hose Size</i>			Dimensioni <i>Dimensions (mm)</i>		
	inch	mm	size	d	H	E
BR480L5	5/32"	4.0	02.5	7.5	6x0.75	12
BR4860L5	5/32"	4.0	02.5	8.1	6x0.75	12
BR3160L5	3/16"	4.8	03	9.0	7X0.75	14
BR14MT1	1/4"	6.3	04	10.8	9x1	17

Codice <i>Part Number</i>	Tubi <i>Hoses</i>	
BR480L5	5/32"	GR78412000
BR4860L5	5/32"	GR7712000 / GR7PA712000
BR3160L5	3/16"	GR7212000
BR14MT1	1/4"	GR7312000 / GR7PA312000

RACCORDI RECUPERABILI PER TUBI SERIE GR7 / REUSABLE FITTINGS FOR GR7 SERIES HOSES

CODOLO LISCIO RECUPERABILE
REUSABLE METRIC STANDPIPE

BEL-BES

Tipo di connessione <i>Connection Type</i>	Codolo liscio <i>Standpipe</i>
Tipo di tenuta <i>Sealing Type</i>	Anello di serraggio <i>Cutting Ring</i>
Normativa <i>Standard</i>	DIN 2353
Materiale <i>Material</i>	Acciaio AVP <i>Carbon Steel</i>
Finitura superficiale <i>Surface Finishing</i>	Zincatura trivalente <i>Zinc Plating</i>

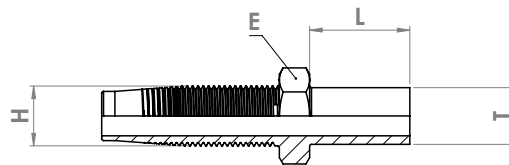

Codice <i>Part Number</i>	Diametro tubo <i>Hose Size</i>			Codolo <i>Pipe</i>	Tipo <i>Type</i>	Dimensioni <i>Dimensions (mm)</i>		
	inch	mm	size			T	L	H
ER448	5/32"	4.0	02.5	4	LL	21	6x0.75	10
ER4316	3/16"	4.8	03	4	LL	21	7x0.75	10
ER514	1/4"	6.4	04	5	LL	22	9x1	12
ER614	1/4"	6.4	04	6	L	21	9x1	12
ER814	1/4"	6.4	04	8	L	22	9x1	12
ER814L	1/4"	6.4	04	8	L	25	9x1	12
ER648	5/32"	4.0	02.5	6	S	21	6x0.75	10
ER648L	5/32"	4.0	02.5	6	S	25	6x0.75	10
ER848	5/32"	4.0	02.5	8	S	30.5	6x0.75	10
ER6316	3/16"	4.8	03	6	S	21	7x0.75	10
ER6316L	3/16"	4.8	03	6	S	25	7x0.75	10
ER8316	3/16"	4.8	03	8	S	22	7x0.75	10
ER1014	1/4"	6.4	04	10	S	22	9x1	12
ER1214	1/4"	6.4	04	12	S	24	9x1	14

OPZIONI:

Boccole e raccordi sono disponibili su richiesta anche con finitura superficiale in Zn-Ni. I raccordi con gola per innesto rapido sono disponibili su richiesta.

OPTIONS:

Ferrules and fittings available on request also with Zn-Ni surface finishing. Fittings with groove for quick coupling available on request.



Per diverse tipologie di connessione, fare riferimento al nostro Catalogo raccordi:
www.zecspa.com/it/download

For different types of connections please refer to our Fittings Catalogue:
www.zecspa.com/en/download

RACCOMANDAZIONI:

L'utilizzo di raccordi recuperabili riduce le prestazioni del tubo assemblato in termini di pressione di scoppio e resistenza agli impulsi. Si consiglia di non superare il 90% della pressione di esercizio come da scheda tecnica del tubo e una temperatura di esercizio di 80 °C.

Per un corretto e sicuro assemblaggio del tubo, si consiglia di utilizzare boccole e raccordi ZEC.

RECOMMENDATIONS:

The use of reusable fittings reduces the hose assembly's performance in terms of burst pressure and impulse resistance. We recommend not to exceed 90% of the working pressure as per hose data sheet and a working temperature of 80°C.

For a correct and safe hose assembly, we recommend the use of ZEC ferrules and fittings.

CODOLO LISCIO 90° RECUPERABILE
REUSABLE 90° METRIC STANDPIPE

BEL-BES 90°

Tipo di connessione <i>Connection Type</i>	Codolo liscio <i>Standpipe</i>
Tipo di tenuta <i>Sealing Type</i>	Anello di serraggio <i>Cutting Ring</i>
Normativa <i>Standard</i>	DIN 2353
Materiale <i>Material</i>	Acciaio AVP <i>Carbon Steel</i>
Finitura superficiale <i>Surface Finishing</i>	Zincatura trivalente <i>Zinc Plating</i>

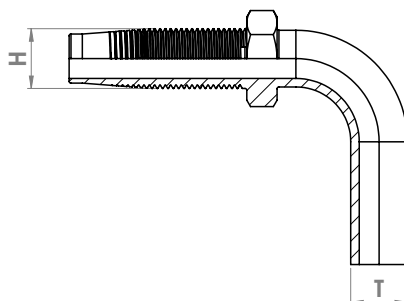

Codice <i>Part Number</i>	Diametro tubo <i>Hose Size</i>			Codolo <i>Pipe</i>	Tipo <i>Type</i>	Dimensioni <i>Dimensions (mm)</i>
	inch	mm	size			H
ER90448	5/32"	4.0	02.5	4	LL	6x0.75
ER904316	3/16"	4.8	03	4	LL	7x0.75
ER90614	1/4"	6.4	04	6	L	9x1
ER90814	1/4"	6.4	04	8	L	9x1
ER90648	5/32"	4.0	02.5	6	S	6x0.75
ER906316	3/16"	4.8	03	6	S	7x0.75
ER908316	3/16"	4.8	03	8	S	7x0.75
ER901014	1/4"	6.4	04	10	S	9x1
ER901214	1/4"	6.4	04	12	S	9x1

CODOLO LISCIO 45° RECUPERABILE
REUSABLE 45° METRIC STANDPIPE

BEL-BES 45°

Tipo di connessione <i>Connection Type</i>	Codolo liscio <i>Standpipe</i>
Tipo di tenuta <i>Sealing Type</i>	Anello di serraggio <i>Cutting Ring</i>
Normativa <i>Standard</i>	DIN 2353
Materiale <i>Material</i>	Acciaio AVP <i>Carbon Steel</i>
Finitura superficiale <i>Surface Finishing</i>	Zincatura trivalente <i>Zinc Plating</i>

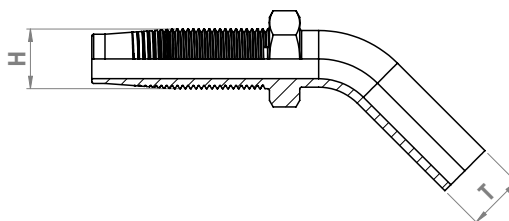

Codice <i>Part Number</i>	Diametro tubo <i>Hose Size</i>			Codolo <i>Pipe</i>	Tipo <i>Type</i>	Dimensioni <i>Dimensions (mm)</i>
	inch	mm	size			H
ER45448	5/32"	4.0	02.5	4	LL	6x0.75
ER454316	3/16"	4.8	03	4	LL	7x0.75
ER45614	1/4"	6.4	04	6	L	9x1
ER45814	1/4"	6.4	04	8	L	9x1
ER45648	5/32"	4.0	02.5	6	S	6x0.75
ER456316	3/16"	4.8	03	6	S	7x0.75
ER451014	1/4"	6.4	04	10	S	9x1

BOCCOLE A PRESSARE PER TUBI SERIE GR7 / SWAGE FERRULES FOR GR7 SERIES HOSES

**BP0L5
BPR7**

Materiale Material	Finitura superficiale Surface Finishing
Acciaio AVP Carbon Steel	Zincatura trivalente Zinc Plating

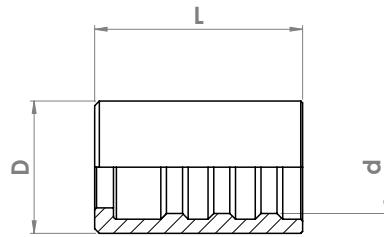

Codice Part Number	Diametro tubo Hose Size			Dimensioni Dimensions (mm)			Tipo di inserto Tail Type
	inch	mm	size	d	D	L	
BP180L5	1/8"	3.5	02	7.8	12	18	0
BP480L5	5/32"	4.0	02.5	8.5	12	20	0
BP532R7	5/32"	4.0	02.5	9.3	13	20	0
BP3160L5	3/16"	4.8	03	9.8	14	22	0
BP316R7	3/16"	4.8	03	10.7	15	26	0
BP14R7	1/4"	6.4	04	12.4	17	29	0

RACCORDI A PRESSARE PER TUBI SERIE GR7 / SWAGE FITTINGS FOR GR7 SERIES HOSES

**CODOLO LISCIO
METRIC STANDPIPE**

BEL-BES

Tipo di connessione <i>Connection Type</i>	Codolo liscio <i>Standpipe</i>
Tipo di tenuta <i>Sealing Type</i>	Anello di serraggio <i>Cutting Ring</i>
Normativa <i>Standard</i>	DIN 2353
Materiale <i>Material</i>	Acciaio AVP <i>Carbon Steel</i>
Finitura superficiale <i>Surface Finishing</i>	Zincatura trivalente <i>Zinc Plating</i>

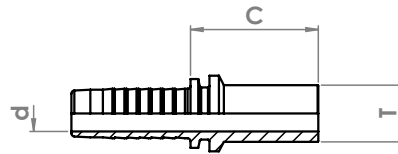

Codice <i>Part Number</i>	Diametro tubo <i>Hose Size</i>			Codolo <i>Pipe</i>	Tipo <i>Type</i>	Dimensioni <i>Dimensions (mm)</i>	
	inch	mm	size			T	C
EP418	1/8"	3.5	02	4	LL	26	1.9
EP618	1/8"	3.5	02	6	L/S	26	1.9
EP818	1/8"	3.5	02	8	L/S	28	1.9
EP448	5/32"	4.0	02.5	4	LL	27	2.4
EP648	5/32"	4.0	02.5	6	L/S	28	2.4
EP648L30	5/32"	4.0	02.5	6	L/S	37	2.4
EP848	5/32"	4.0	02.5	8	L	26	2.4
EP4316	3/16"	4.8	03	4	LL	26	3
EP6316	3/16"	4.8	03	6	L/S	30	3
EP8316	3/16"	4.8	03	8	L/S	29	3
EP514	1/4"	6.4	04	5	LL	28	4
EP614	1/4"	6.4	04	6	L	32	4
EP814	1/4"	6.4	04	8	L/S	29	4
EP1014	1/4"	6.4	04	10	S	32	4
EP1214	1/4"	6.4	04	12	S	30	4

**CODOLO LISCIO 90°
90° METRIC STANDPIPE**

BEL-BES 90°

Tipo di connessione <i>Connection Type</i>	Codolo liscio <i>Standpipe</i>
Tipo di tenuta <i>Sealing Type</i>	Anello di serraggio <i>Cutting Ring</i>
Normativa <i>Standard</i>	DIN 2353
Materiale <i>Material</i>	Acciaio AVP <i>Carbon Steel</i>
Finitura superficiale <i>Surface Finishing</i>	Zincatura trivalente <i>Zinc Plating</i>

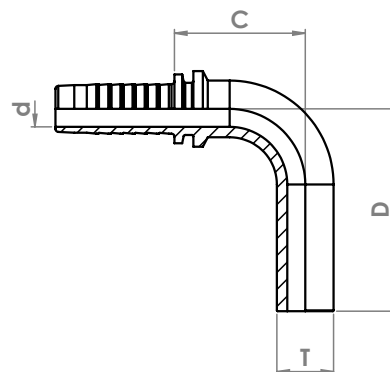

Codice <i>Part Number</i>	Diametro Tubo <i>Hose Size</i>			Codolo <i>Pipe</i>	Tipo <i>Type</i>	Dimensioni <i>Dimensions (mm)</i>		
	inch	mm	size			T	C	d
EP90448	5/32"	4.0	02.5	4	LL	24	2.4	32
EP90648	5/32"	4.0	02.5	6	L/S	24	2.4	32
EP904316	3/16"	4.8	03	4	LL	24	3	32
EP906316	3/16"	4.8	03	6	L/S	24	3	37
EP908316	3/16"	4.8	03	8	L/S	24	3	39
EP90614	1/4"	6.4	04	6	L	25	4	37
EP90814	1/4"	6.4	04	8	L/S	25	4	39
EP901014	1/4"	6.4	04	10	S	25	4	42
EP901214	1/4"	6.4	04	12	S	25	4	45

CODOLO LISCIO 45°
45° METRIC STANDPIPE
BEL-BES 45°

Tipo di connessione <i>Connection Type</i>	Codolo liscio <i>Standpipe</i>
Tipo di tenuta <i>Sealing Type</i>	Anello di serraggio <i>Cutting Ring</i>
Normativa <i>Standard</i>	DIN 2353
Materiale <i>Material</i>	Acciaio AVP <i>Carbon Steel</i>
Finitura superficiale <i>Surface Finishing</i>	Zincatura trivalente <i>Zinc Plating</i>

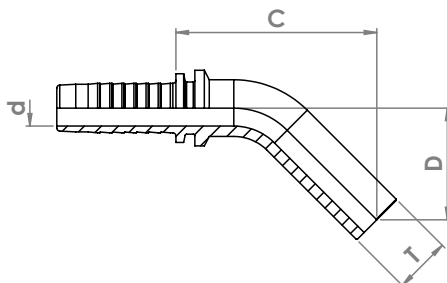

Codice <i>Part Number</i>	Diametro tubo <i>Hose Size</i>			Codolo <i>Pipe</i>	Tipo <i>Type</i>	Dimensioni <i>Dimensions (mm)</i>		
	inch	mm	size			C	d	D
EP45448	5/32"	4.0	02.5	4	LL	41	2.4	20
EP45648	5/32"	4.0	02.5	6	L/S	41	2.4	20
EP456316	3/16"	4.8	03	6	L/S	41	3	20
EP458316	3/16"	4.8	03	8	L/S	44	3	23
EP45614	1/4"	6.4	04	6	L	42	4	30
EP45814	1/4"	6.4	04	8	L/S	41	4	29
EP451014	1/4"	6.4	04	10	S	42	4	30
EP451214	1/4"	6.4	04	12	S	42	4	30

OPZIONI:

Boccole e raccordi sono disponibili su richiesta anche con finitura superficiale in Zn-Ni. I raccordi con gola per innesto rapido sono disponibili su richiesta.

OPTIONS:

Ferrules and fittings available on request also with Zn-Ni surface finishing. Fittings with groove for quick coupling available on request.



Per diverse tipologie di connessione, fare riferimento al nostro Catalogo raccordi:
www.zecspa.com/it/download

For different types of connections please refer to our Fittings Catalogue:
www.zecspa.com/en/download

RACCOMANDAZIONI:

Per un corretto e sicuro assemblaggio del tubo, si consiglia di utilizzare boccole e raccordi ZEC.

RECOMMENDATIONS:

For a correct and safe hose assembly, we recommend the use of ZEC ferrules and fittings.

Le corrette istruzioni e i parametri di crimpatura sono disponibili e sempre aggiornati nell'Area Riservata del nostro sito:
www.zecspa.com/it/area-riservata

Proper crimping instructions and parameters are available and always updated in the Reserved Area of our website:
www.zecspa.com/en/reserved-area



GR7

TUBO RACCORDATO PER INGRASSATORI HOSE ASSEMBLIES FOR GREASE GUNS



Caratteristiche principali

- Peso ridotto e compattezza
- Elevata flessibilità
- Resistente al kinking
- Soluzione pronta all'installazione

Main Features

- Low weight and compactness
- High flexibility
- Kinking resistant
- Ready for installation

Caratteristiche tecniche

- **Caratteristiche tecnico-costruttive:**
Anima in poliestere o polietilene, rinforzo trecciato in fibra di poliestere e rivestimento esterno in poliuretano nero opaco.
- **Temperature di esercizio:**
Da -40°C (-40°F) a +80°C (+176°F).
In caso di acqua, o fluidi a base acquosa, la temperatura massima di lavoro è di +70°C (+158°F). Temperature superiori a +80°C possono ridurre la durata di vita utile del tubo.
- **Valore max. di vuoto:**
pressione assoluta 0.93bar; 700 mmHg.
(pressione assoluta 13.5 psi; 27.5 inchHg).
- **Variation max. di lunghezza alla pressione di esercizio:**
Da -1.5% a +1.5%
- **Specifiche:**
Tubi conformi alla normativa DIN 1283.

Technical Features

- **Technical-constructive Features:**
Inner core of polyester or polyethylene, braided reinforcement of polyester fiber and outer covering of matte black polyurethane.
- **Working Temperatures:**
From -40°C (-40°F) to +80°C (+176°F).
Max. working temperature with water or water based fluids is +70°C (+158°F). Temperatures higher than +80°C may reduce hose lifespan.
- **Max. Vacuum Value:**
absolute pressure 0.93bar; 700 mmHg.
(absolute pressure 13.5 psi; 27.5 inchHg).
- **Max. Length Variation at Working Pressure:**
From -1.5% to +1.5%
- **Specifications:**
These hoses meet DIN 1283 standard.

Scheda tecnica - Data Sheet



CODE	mm	inch	DN	mm	inch	bar	psi	bar	psi	mm	inch	g/m	Hose length mm	FITTINGS TYPE
TR102430018BSP	4.0	0.157	4	10.0	0.394	400	5800	900	13050	35	1.378	75	300	1/8" BSPT
TR102440018	4.0	0.157	4	10.0	0.394	400	5800	900	13050	35	1.378	75	400	1/8" BSPP
TR102440018BSP	4.0	0.157	4	10.0	0.394	400	5800	900	13050	35	1.378	75	400	1/8" BSPT
TR102450018BSP	4.0	0.157	4	10.0	0.394	400	5800	900	13050	35	1.378	75	500	1/8" BSPT
TR102480018BSP	4.0	0.157	4	10.0	0.394	400	5800	900	13050	35	1.378	75	800	1/8" BSPT

Sistemi di misurazione & mini attrezzature oleodinamiche ad alta pressione /

Measuring Systems & Mini High Pressure Hydraulic Equipment



Le soluzioni ZEC per sistemi di misurazione e mini attrezzature oleodinamiche ad alta pressione

ZEC offre una gamma dedicata di tubi termoplastici microforati, progettati per test di pressione in linea e per utilizzo oleodinamico ad alta pressione, adatti per la conduzione di fluidi oleodinamici e trasferimento di gas.

CARATTERISTICHE TECNICHE

- Compattezza
- Leggerezza
- Elevata flessibilità e resistenza al kinking

APPLICAZIONI



FRENI IDRAULICI DI BICICLETTE



SISTEMI IDRAULICI DI PROVA IN PRESSIONE



SISTEMI AUTOMOBILISTICI DI APERTURA DEL TETTO



MINI ATTREZZATURE IDRAULICHE AD ALTA PRESSIONE

CERTIFICAZIONI

Tutti i tubi ZEC sono prodotti in conformità al **Regolamento Europeo CE 1907/2006 "REACH"** e alla **Direttiva Europea UE 65/2011 "RoHS"**.

QUALITÀ

Il sistema di qualità certificato **ISO 9001:2015 ZEC** assicura un controllo continuo e costante del processo produttivo, garantendo il rispetto delle buone pratiche di fabbricazione.

ZEC Solutions for Measuring Systems and Mini High Pressure Hydraulic Equipment

ZEC offers a dedicated range of thermoplastic micro bore hoses designed for in line pressure testing and high pressure hydraulic use, suitable for the conduction of hydraulic fluids and gas transfer.

TECHNICAL FEATURES

- Compact
- Lightweight
- Very flexible and kinking resistant

APPLICATIONS



HYDRAULIC BIKE BRAKES



HYDRAULIC PRESSURE TEST SYSTEMS



AUTOMOTIVE ROOF OPENING SYSTEMS



MINI HIGH PRESSURE HYDRAULIC EQUIPMENT

CERTIFICATIONS

All ZEC hoses are manufactured in conformity to **European Regulation EU 1907/2006 "REACH"** and **European Directive EU 2011/65 "RoHS"**.

QUALITY

The certified **ISO 9001:2015 ZEC** quality system ensures a continuous and constant control of the production process, guaranteeing compliance with Good Manufacturing Practices.



Measuring Systems & Mini High Pressure Hydraulic Equipment



TS7/TS7-PA

MICRO BORE HOSES



Caratteristiche principali

- Applicazioni oleodinamiche ad alta pressione
- Leggero
- Elevata flessibilità
- Resistente al kinking

Main Features

- High pressure hydraulic applications
- Lightweight
- High flexibility
- Kinking resistant

Caratteristiche tecniche

- **Caratteristiche tecnico-costruttive:**
Anima interna in poliestere (o poliammide* **), rinforzo con treccia singola in poliestere e rivestimento esterno in poliuretano (o poliammide*) nero lucido, forato per convogliamento aria e gas compatibili.
Su richiesta rivestimento in poliuretano opaco.
- **Temperature di utilizzo:**
Da -40°C (-40°F) a +100°C (+212°F).
In caso di acqua, o fluidi a base acquosa, la temperatura max. di lavoro è di +70°C (+158°F).
Temperature superiori a +80°C possono ridurre la durata di vita utile del tubo.
- **Valore max. di vuoto:**
pressione assoluta 0.93bar; 700 mmHg.
(pressione assoluta 13.5 psi; 27.5 inchHg).
- **Variazione max. di lunghezza alla pressione di esercizio:**
Da -1.5% a +1.5%
- **Note:**
La marcatura standard indica solo il fattore di sicurezza 1:3.

Technical Features

- **Technical-constructive Features:**
Inner core of polyester (or polyamide* **), single braided polyester reinforcement and outer covering of shiny black polyurethane (or polyamide*), pin-pricked for conveying air and compatible gases. Matte polyurethane cover available on request.
- **Working Temperatures:**
From -40°C (-40°F) to +100°C (+212°F).
Max. working temperature with water or water-based fluids is +70°C (+158°F).
Temperatures higher than +80°C may reduce hose lifespan.
- **Max. Vacuum Value:**
absolute pressure 0.93 bar; 700 mmHg.
(absolute pressure 13.5 psi; 27.5 inchHg).
- **Max. Length Variation at Working Pressure:**
From -1.5% to +1.5%
- **Note:**
Standard branding specifies 1:3 SF only.

Scheda tecnica - Data Sheet



CODE	mm	inch	DN	mm	inch	bar	psi	bar	psi	bar	psi	mm	inch	g/m	lbs/ft	FERRULE
TS750210100	2.1	0.0827	2	5.0	0.197	300	4350	400	5800	1200	17400	20	0.787	21	0.0141	BPTS50
TS750213100PA*	2.1	0.0827	2	5.0	0.197	300	4350	400	5800	1200	17400	20	0.787	19	0.0128	BPTS50
TS750220100PA**	2.2	0.0866	2	5.0	0.197	187	2710	250	3630	750	10880	20	0.787	19	0.0128	BPTS50
TS756250100	2.5	0.0984	2	5.6	0.220	187	2710	250	3630	750	10880	20	0.787	24	0.0161	BPTS55
TS756250100PA**	2.5	0.0984	2	5.6	0.220	187	2710	250	3630	750	10880	20	0.787	24	0.0161	BPTS55

* Anima e copertura in PA
** Anima in PA

* PA inner core and cover
** PA inner core

TS8/TS8-PA

MICRO BORE HOSES



Caratteristiche principali

- Applicazioni oleodinamiche ad alta pressione
- Leggero
- Elevata flessibilità
- Resistente al kinking

Main Features

- High pressure hydraulic applications
- Lightweight
- High flexibility
- Kinking resistant

Caratteristiche tecniche

- **Caratteristiche tecnico-costruttive:**
Anima interna in poliestere (o poliammide* **), rinforzo in treccia singola di fibra aramidica e rivestimento esterno in poliuretano (o poliammide **) nero lucido, forato per convogliamento aria e gas compatibili. Su richiesta rivestimento in poliuretano opaco.
- **Temperature di utilizzo:**
Da -40°C (-40°F) a +100°C (+212°F).
In caso di acqua, o fluidi a base acquosa, la temperatura max. di lavoro è di +70°C (+158°F). Temperature superiori a +80°C possono ridurre la durata di vita utile del tubo.
- **Valore max. di vuoto:**
pressione assoluta 0.93bar; 700 mmHg.
(pressione assoluta 13.5 psi; 27.5 inchHg).
- **Variazione max. di lunghezza alla pressione di esercizio:**
Da -1.5% a +1.5%
- **Specifiche:**
Il tubo DN2 con anima e rivestimento esterno di PA (rif. TS850213100PA) ha superato il test impulsi ad 1 milione di cicli.
- **Note:**
La marcatura standard indica solo il fattore di sicurezza 1:3.

Technical Features

- **Technical-constructive Features:**
Inner core of polyester (or polyamide* **), single braided aramid reinforcement and outer covering of shiny black polyurethane (or polyamide**), pin-pricked for conveying air and compatible gases. Matte polyurethane cover available on request.
- **Working Temperatures:**
From -40°C (-40°F) to +100°C (+212°F).
Max. working temperature with water or water-based fluids is +70°C (+158°F).
Temperatures higher than +80°C may reduce hose lifespan.
- **Max. Vacuum Value:**
absolute pressure 0.93 bar; 700 mmHg.
(absolute pressure 13.5 psi; 27.5 inchHg).
- **Max. Length Variation at Working Pressure:**
-1.5% to +1.5%
- **Specifications:**
DN2 hose with inner core and PA cover (ref. TS850213100PA) has passed impulse test at 1 mio cycles.
- **Note:**
Standard branding specifies 1:3 SF only.

Scheda tecnica - Data Sheet



CODE	mm	inch	DN	mm	inch	bar	psi	bar	psi	bar	psi	mm	inch	g/m	lbs/ft	FERRULE
TS850210100	2.1	0.0827	2	5.0	0.197	500	7250	666	9660	2000	29010	20	0.787	19	0.0128	BPTS50
TS850210100PA*	2.1	0.0827	2	5.0	0.197	500	7250	666	9660	2000	29010	20	0.787	18	0.0121	BPTS50
TS850213100PA**	2.1	0.0827	2	5.0	0.197	500	7250	666	9660	2000	29010	20	0.787	17	0.0114	BPTS50
TS855210100	2.1	0.0827	2	5.5	0.216	472	6850	630	9140	1890	27410	20	0.787	23	0.0154	BPTS55
TS855260100	2.6	0.1024	3	5.5	0.216	500	7250	666	9660	2000	29010	20	0.787	23	0.0154	BPTS55
TS864290100PA*	2.9	0.1142	3	6.4	0.252	500	7250	666	9660	2000	29010	35	1.378	28	0.0188	BPTSM65
TS864293100PA**	2.9	0.1142	3	6.4	0.252	500	7250	666	9660	2000	29010	35	1.378	26	0.0178	BPTSM65
TS855300100PA*	3.0	0.1181	3	5.5	0.216	472	6850	630	9140	1890	27410	20	0.787	20.4	0.0137	BPTS55
TS860300100	3.0	0.1181	3	6.0	0.236	400	5800	533	7730	1600	23210	30	1.181	26	0.0178	BPTS60
TS8840100	4.0	0.1575	4	8.0	0.315	412	5970	550	7980	1650	23930	35	1.378	44	0.0296	BP480L5
TS880410100PA*	4.1	0.1614	4	8.0	0.315	500	7250	666	9660	2000	29010	40	1.575	38	0.0255	BP480L5
TS880413100PA**	4.1	0.1614	4	8.0	0.315	500	7250	666	9660	2000	29010	40	1.575	36	0.0242	BP480L5

* Anima e copertura in PA ** Anima in PA

* PA inner core and cover ** PA inner core

BOCCOLE A PRESSARE PER TUBI SERIE TS7-TS8 / SWAGE FERRULES FOR TS7-TS8 SERIES HOSES

BOCCOLA A PRESSARE SERIE TEST
SWAGE FERRULE TEST SERIES

Tipo Type	Materiale Material	Finitura superficiale Surface Finishing
TS	Acciaio AVP Carbon Steel	Zincatura trivalente Zinc Plating

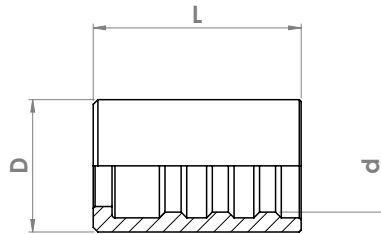

Codice Part Number	Diametro tubo Hose Size			Dimensioni Dimensions (mm)			Tipo di inserto Tail Type
	inch	mm	size	d	D	L	
BPTS50	1/12" DN2	2.1	-	5.2	8	14	TS
BPTS55	1/12" DN2	2.1	-	5.7	8	15	TS
BPTS5525	1/10"	2.6	-	5.6	8	14	TS
BPTS60	1/8"	3.0	02	6.3	9	15	TS
BP480L5	5/32"	4.0	02.5	8.5	12	20	0

Swage Fittings for TS7/TS8 Hoses

	MASCHIO BSPP SEDE PIANA BSPP MALE FLAT SEAT	31		FEMMINA METRICA 90° CON CONO / O-RING 24° SERIE LEGGERA DKOL METRIC FEMALE 90° WITH 24° TAPER / O-RING LIGHT DKOL SERIES	35
	MASCHIO NPT NPT MALE	31		FEMMINA METRICA CON CONO / O-RING 24° SERIE PESANTE DKOS METRIC FEMALE WITH 24° TAPER / O-RING HEAVY DKOS SERIES	36
	FEMMINA GIREVOLE SEDE PIANA CON O-RING PER MANOMETRO SWIVEL FEMALE FLAT SEAT WITH O-RING FOR PRESSURE GAUGE	32		FEMMINA METRICA 90° CON CONO / O-RING 24° SERIE PESANTE DKOS METRIC FEMALE 90° WITH 24° TAPER / O-RING HEAVY DKOS SERIES	36
	FEMMINA 90° GIREVOLE SEDE PIANA CON O-RING PER MANOMETRO SWIVEL 90° FEMALE FLAT SEAT WITH O-RING FOR PRESSURE GAUGE	32		RACCORDO OCCHIO BANJO FITTING	37
	FEMMINA CON SVASATURA CONICA 60° FEMALE WITH 60° CONICAL BORE	33		RACCORDO OCCHIO A 90° 90° BANJO FITTING	37
	FEMMINA BSPP 90° CON SVASATURA CONICA 60° BSPP 90° FEMALE WITH 60° CONICAL BORE	33		BULLONE FORATO BORED BOLT	38
	FEMMINA JIC SVASATURA CONICA 74° JIC FEMALE 90° WITH 74° CONICAL BORE	34		FEMMINA ORFS O-RING FACE SEAL ORFS FEMALE O-RING FACE SEAL	38
	FEMMINA JIC 90° CON SVASATURA CONICA 74° JIC FEMALE 90° WITH 74° CONICAL BORE	34		FEMMINA 90° ORFS O-RING FACE SEAL 90° ORFS FEMALE O-RING FACE SEAL	38
	FEMMINA METRICA CON CONO/ O-RING 24° SERIE LEGGERA DKOL METRIC FEMALE WITH 24° TAPER / O-RING LIGHT DKOL SERIES	35		FEMMINA GIREVOLE A SPINA PER RACCORDO DI CONTROLLO CON ZIGRINATURA KNURLED SWIVEL PIN FEMALE TEST COUPLING FITTING	39

	FEMMINA GIREVOLE A SPINA PER RACCORDO DI CONTROLLO CON ESAGONO SWIVEL PIN FEMALE TEST COUPLING FITTING WITH HEXAGON	39		MINIPRESA M16X2 FEMMINA - TENUTA DKO 24° O-RING TEST COUPLING M16X2 FEMALE - DKO 24° O-RING SEALING	42
	CODOLO LISCIO DIRITTO STRAIGHT STANDPIPE	40		MINIPRESA M16X2 FEMMINA INTERMEDIA - TENUTA CEL-S 24° TEST COUPLING M16X2 INTERMEDIATE FEMALE - CEL-S 24° SEALING	43
	CODOLO LISCIO A 90° ELBOW 90° STANDPIPE	40		MINIPRESA M16X2 MASCHIO FILETTATURA CONICA - TENUTA SUL FILETTO TEST COUPLING M16X2 MALE TAPER THREAD - THREAD SEALING	44
	CODOLO LISCIO A 45° ELBOW 45° STANDPIPE	41		MINIPRESA M16X2 MASCHIO FILETTATURA CILINDRICA - TENUTA O-RING RADIALE TEST COUPLING M16X2 MALE PARALLEL THREAD - RADIAL O-RING SEALING	44
	CAPPUCCIO PARAPOLVERE DUST PROTECTION CAP	41		MINIPRESA M16X2 CODOLO LISCIO TEST COUPLING M16X2 STANDPIPE	45
	MINIPRESA M16X2 MASCHIO FILETTATURA CILINDRICA - TENUTA O-RING SOTTOTESTA TEST COUPLING M16X2 MALE PARALLEL THREAD - UNDER HEAD O-RING SEALING	42		NIPLES PER COLLEGAMENTO MANOMETRO M16X2 NIPPLE FOR PRESSURE GAUGE CONNECTION M16X2	45

ZEC fornisce su richiesta raccordi del tipo Microtubi e Miniprese anche in Acciaio Inox AISI 316L.
Micro Hoses type fittings and Test Couplings are available, on request, also in AISI 316L Stainless Steel.

Per una corretta e sicura operazione di crimpatura, si consiglia l'uso di boccole e raccordi ZEC. Istruzioni e diametri di crimpatura adeguati sono disponibili e sempre aggiornati nell'Area Riservata del nostro sito: www.zecspa.com/it/reserved-area.

For a correct and safe crimping operation, we recommend the use of ZEC ferrules and fittings. Proper instructions and crimping diameters are available and always updated in the Reserved Area of our website: www.zecspa.com/en/reserved-area.

MASCHIO BSPP SEDE PIANA BSPP MALE FLAT SEAT

Materiale Material	Finitura superficiale Surface finishing
Acciaio AVP Carbon Steel	Zincatura trivalente Zinc Plating

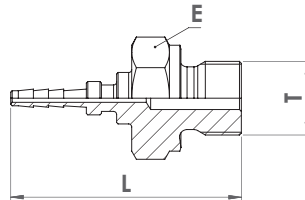

Codice Part Number	Diametro tubo Hose Size			Filetto Thread	Dimensioni Dimensions (mm)	
	inch	mm	size		L	E
RTSMD18	1/12"	2.1	-	1/8"-28	30	13
RTSMD14	1/12"	2.1	-	1/4"-19	36	19
RPMD18DN3	1/8"	3.0	02	1/8"-28	34	14
RPMD14DN3	1/8"	3.0	02	1/4"-19	39	19
RPMD1848	5/32"	4.0	02.5	1/8"-28	34	14
RPMD1448	5/32"	4.0	02.5	1/4"-19	39	19

MASCHIO NPT NPT MALE

Materiale Material	Finitura superficiale Surface Finishing
Acciaio AVP Carbon Steel	Zincatura trivalente Zinc Plating

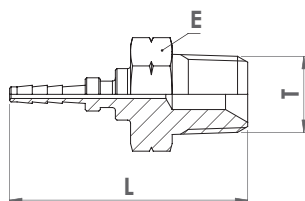

Codice Part Number	Diametro tubo Hose Size			Filetto Thread	Dimensioni Dimensions (mm)	
	inch	mm	size		L	E
RTSMD18NPT	1/12"	2.1	-	1/8"-27	32	13
RTSMD14NPT	1/12"	2.1	-	1/4"-18	36	17
RPMD18NPTDN3	1/8"	3.0	02	1/8"-27	33	12
RPMD14NPTDN3	1/8"	3.0	02	1/4"-18	38	17
RPMD18NPT48	5/32"	4.0	02.5	1/8"-27	35	12
RPMD14NPT48	5/32"	4.0	02.5	1/4"-18	41	17

FEMMINA GIREVOLE SEDE PIANA CON O-RING PER MANOMETRO SWIVEL FEMALE FLAT SEAT WITH O-RING FOR PRESSURE GAUGE

Materiale Material	Finitura superficiale Surface Finishing
Acciaio AVP Carbon Steel	Zincatura trivalente Zinc Plating

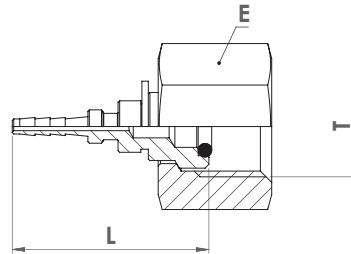

Codice Part Number	Diametro tubo Hose Size			Filetto Thread	Dimensioni Dimensions (mm)	
	inch	mm	size	T	L	E
RTSFD140R	1/12"	2.1	-	1/4"-19	26	17
RTSFD380R	1/12"	2.1	-	3/8"-19	24	22
RTSFD120R	1/12"	2.1	-	1/2"-14	27	24
RTSFD12150R	1/12"	2.1	-	M12x1.5	26	14
RTSFD14150R	1/12"	2.1	-	M14x1.5	26	19
RTSFD20150R	1/12"	2.1	-	M20x1.5	34	24
RPF140RD3	1/8"	3.0	02	1/4"-19	30	19
RPF120RD3	1/8"	3.0	02	1/2"-14	38	27
RPF20150RD3	1/8"	3.0	02	M20x1.5	38	24
RPF140R48	5/32"	4.0	02.5	1/4"-19	37	19
RPF120R48	5/32"	4.0	02.5	1/2"-14	37	27
RPF20150R48	5/32"	4.0	02.5	M20x1.5	37	24

FEMMINA 90° GIREVOLE SEDE PIANA CON O-RING PER MANOMETRO SWIVEL 90° FEMALE FLAT SEAT WITH O-RING FOR PRESSURE GAUGE

Materiale Material	Finitura superficiale Surface Finishing
Acciaio AVP Carbon Steel	Zincatura trivalente Zinc Plating

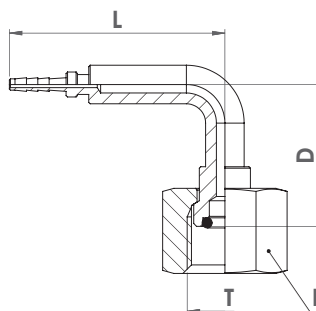

Codice Part Number	Diametro tubo Hose Size			Filetto Thread	Dimensioni Dimensions (mm)		
	inch	mm	size	T	L	D	E
RTSF90140R	1/12"	2.1	-	1/4"-19	38	25	19
RTSF90120R	1/12"	2.1	-	1/2"-14	42	38	27
RTSF9020150R	1/12"	2.1	-	M20x1.5	42	38	24
RPF90140RD3	1/8"	3.0	02	1/4"-19	38	25	19
RPF90120RD3	1/8"	3.0	02	1/2"-14	42	38	27
RPF9020150RD3	1/8"	3.0	02	M20x1.5	42	38	24
RPF90140R48	5/32"	4.0	02.5	1/4"-19	43	25	19
RPF90120R48	5/32"	4.0	02.5	1/2"-14	47	38	27
RPF9020150R48	5/32"	4.0	02.5	M20x1.5	47	38	24

FEMMINA CON SVASATURA CONICA 60° FEMALE WITH 60° CONICAL BORE

Materiale Material	Finitura superficiale Surface Finishing
Acciaio AVP Carbon Steel	Zincatura trivalente Zinc Plating

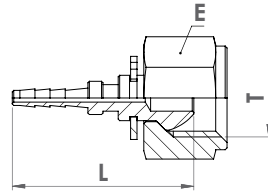

Codice Part Number	Diametro tubo Hose Size			Filetto Thread	Dimensioni Dimensions (mm)	
	inch	mm	size	T	L	E
RTSFD18	1/12"	2.1	-	1/8"-28	24	13
RTSFD14	1/12"	2.1	-	1/4"-19	27	17
RTSFD38	1/12"	2.1	-	3/8"-19	27	22
RTSFD101	1/12"	2.1	-	M10x1	24	12
RTSFD1215	1/12"	2.1	-	M12x1.5	24	14
RTSFD1415	1/12"	2.1	-	M14x1.5	27	17
RTSFD1425	1/10"	2.5	-	1/4"-19	27	17
RPF18DN3	1/8"	3.0	02	1/8"-28	28	14
RTSFD1430	1/8"	3.0	02	1/4"-19	27	17
RPF101DN3	1/8"	3.0	02	M10x1	28	12
RPF1848	5/32"	4.0	02.5	1/8"-28	32	14
RPF1448	5/32"	4.0	02.5	1/4"-19	32	17

FEMMINA BSPP 90° CON SVASATURA CONICA 60° BSPP 90° FEMALE WITH 60° CONICAL BORE

Materiale Material	Finitura superficiale Surface Finishing
Acciaio AVP Carbon Steel	Zincatura trivalente Zinc Plating

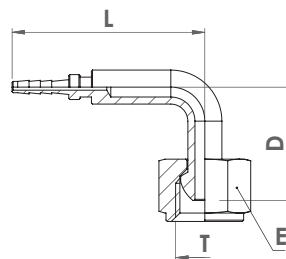

Codice Part Number	Diametro tubo Hose Size			Filetto Thread	Dimensioni Dimensions (mm)		
	inch	mm	size	T	L	D	E
RTSF9018	1/12"	2.1	-	1/8"-28	26	16.5	13
RTSF9014	1/12"	2.1	-	1/4"-19	26	19	17
RPF9018DN3	1/8"	3.0	02	1/8"-28	39	26	14
RPF9014DN3	1/8"	3.0	02	1/4"-19	37	28	17
RPF901848	5/32"	4.0	02.5	1/8"-28	38	20	14
RPF901448	5/32"	4.0	02.5	1/4"-19	41	28	17

FEMMINA JIC SVASATURA CONICA 74° JIC FEMALE WITH 74° CONICAL BORE

Materiale Material	Finitura superficiale Surface Finishing
Acciaio AVP Carbon Steel	Zincatura trivalente Zinc Plating

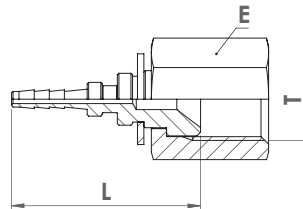

Codice Part Number	Diametro tubo Hose Size			Filetto Thread	Dimensioni Dimensions (mm)	
	inch	mm	size	T	L	E
RTSFD38J	1/12"	2.1	-	3/8"-24	25	12
RTSFD716J	1/12"	2.1	-	7/16"-20	23	14
RTSFD12J	1/12"	2.1	-	1/2"-20	26	17
RTSFD916J	1/12"	2.1	-	9/16"-18	29	17
RPF38JDN3	1/8"	3.0	02	3/8"-24	27	12
RPF716JDN3	1/8"	3.0	02	7/16"-20	29	14
RPF12JDN3	1/8"	3.0	02	1/2"-20	30	17
RPF916JDN3	1/8"	3.0	02	9/16"-18	33	17
RPF38J48	5/32"	4.0	02.5	3/8"-24	29	12
RPF716J48	5/32"	4.0	02.5	7/16"-20	28	14
RPF12J48	5/32"	4.0	02.5	1/2"-20	30	17

FEMMINA JIC 90° CON SVASATURA CONICA 74° JIC FEMALE 90° WITH 74° CONICAL BORE

Materiale Material	Finitura superficiale Surface Finishing
Acciaio AVP Carbon Steel	Zincatura trivalente Zinc Plating

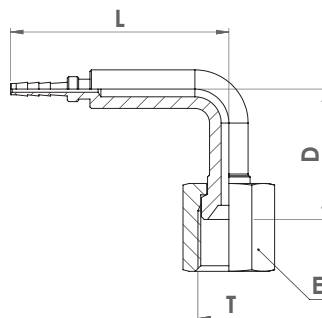

Codice Part Number	Diametro tubo Hose Size			Filetto Thread	Dimensioni Dimensions (mm)		
	inch	mm	size	T	L	D	E
RTSF9038J	1/12"	2.1	-	3/8"-24	40	24	12
RTSF90716J	1/12"	2.1	-	7/16"-20	39	23	14
RTSF9012J	1/12"	2.1	-	1/2"-20	39	23	17
RPF9038JDN3	1/8"	3.0	02	3/8"-24	40	24	12
RPF90716JDN3	1/8"	3.0	02	7/16"-20	47	23	14
RPF9012JDN3	1/8"	3.0	02	1/2"-20	44	23	17
RPF9038J48	5/32"	4.0	02.5	3/8"-24	40	24	12
RPF90716J48	5/32"	4.0	02.5	7/16"-20	44	23	14
RPF9012J48	5/32"	4.0	02.5	1/2"-20	44	23	17

FEMMINA METRICA CON CONO / O-RING 24° SERIE LEGGERA DKOL METRIC FEMALE WITH 24° TAPER / O-RING LIGHT DKOL SERIES

Materiale Material	Finitura superficiale Surface Finishing
Acciaio AVP Carbon Steel	Zincatura trivalente Zinc Plating

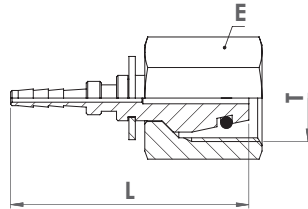

Codice Part Number	Diametro tubo Hose Size			Filetto Thread	Codolo Pipe	Dimensioni Dimensions (mm)	
	inch	mm	size	T		L	E
RTSFD12156DIN	1/12"	2.1	-	M12x1.5	6	32	14
RTSFD14158DIN	1/12"	2.1	-	M14x1.5	8	32	17
RTSFD161510DIN	1/12"	2.1	-	M16x1.5	10	32	19
RTSFD181512DIN	1/12"	2.1	-	M18x1.5	12	34	22
RPFDKOL12156DN3	1/8"	3.0	02	M12x1.5	6	35	14
RPFDKOL14158DN3	1/8"	3.0	02	M14x1.5	8	35	17
RPFDKOL161510DN3	1/8"	3.0	02	M16x1.5	10	37	19
RPFDKOL12155326	5/32"	4.0	02.5	M12x1.5	6	36	14
RPFDKOL1415488	5/32"	4.0	02.5	M14x1.5	8	36	17
RPFDKOL16154810	5/32"	4.0	02.5	M16x1.5	10	37	19
RPFDKOL18154812	5/32"	4.0	02.5	M18x1.5	12	38	22

FEMMINA METRICA 90° CON CONO / O-RING 24° SERIE LEGGERA DKOL METRIC FEMALE 90° WITH 24° TAPER / O-RING LIGHT DKOL SERIES

Materiale Material	Finitura superficiale Surface Finishing
Acciaio AVP Carbon Steel	Zincatura trivalente Zinc Plating

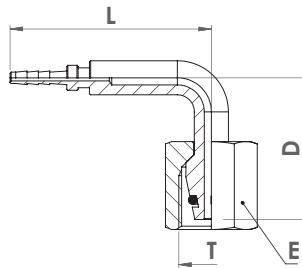

Codice Part Number	Diametro tubo Hose Size			Filetto Thread	Codolo Pipe	Dimensioni Dimensions (mm)		
	inch	mm	size	T		L	D	E
RTSF901215DIN	1/12"	2.1	-	M12x1.5	6	26	25	14
RTSF9014158DIN	1/12"	2.1	-	M14x1.5	8	41	36	17
RTSF90161510DIN	1/12"	2.1	-	M16x1.5	10	42	40	19
RPF90DKOL1215DN3	1/8"	3.0	02	M12x1.5	6	38	25	14
RPF90DKOL1415DN3	1/8"	3.0	02	M14x1.5	8	41	36	17
RPF90DKOL1615DN3	1/8"	3.0	02	M16x1.5	10	47	40	19
RPF90DKOL12155326	5/32"	4.0	02.5	M12x1.5	6	38	25	14
RPF90DKOL1415488	5/32"	4.0	02.5	M14x1.5	8	46	36	17
RPF90DKOL16154810	5/32"	4.0	02.5	M16x1.5	10	47	40	19
RPF90DKOL18154812	5/32"	4.0	02.5	M18x1.5	12	47	40	22

FEMMINA METRICA CON CONO / O-RING 24° SERIE PESANTE DKOS METRIC FEMALE WITH 24° TAPER / O-RING HEAVY DKOS SERIES

Materiale Material	Finitura superficiale Surface Finishing
Acciaio AVP Carbon Steel	Zincatura trivalente Zinc Plating

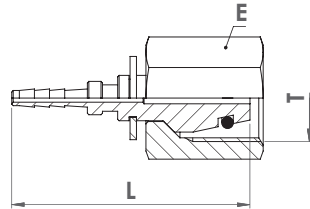

Codice Part Number	Diametro tubo Hose Size			Filetto Thread	Codolo Pipe	Dimensioni Dimensions (mm)	
	inch	mm	size	T		L	E
RTSFD14156DIN	1/12"	2.1	-	M14x1.5	6	32	17
RTSFD16158DIN	1/12"	2.1	-	M16x1.5	8	35	19
RTSFD181510DIN	1/12"	2.1	-	M18x1.5	10	32	22
RTSFD201512DIN	1/12"	2.1	-	M20x1.5	12	34	24
RPFDKOS1415DN3	1/8"	3.0	02	M14x1.5	6	35	17
RPFDKOS1615DN3	1/8"	3.0	02	M16x1.5	8	35	19
RPFDKOS1815DN3	1/8"	3.0	02	M18x1.5	10	37	22
RPFDKOS1415486	5/32"	4.0	02.5	M14x1.5	6	36	17
RPFDKOS1615488	5/32"	4.0	02.5	M16x1.5	8	36	19
RPFDKOS18154810	5/32"	4.0	02.5	M18x1.5	10	37	22
RPFDKOS20154812	5/32"	4.0	02.5	M20x1.5	12	40	24

FEMMINA METRICA 90° CON CONO / O-RING 24° SERIE PESANTE DKOS METRIC FEMALE 90° WITH 24° TAPER / O-RING HEAVY DKOS SERIES

Materiale Material	Finitura superficiale Surface Finishing
Acciaio AVP Carbon Steel	Zincatura trivalente / Zinc Plating

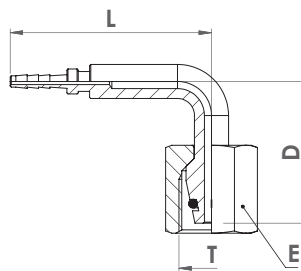

Codice Part Number	Diametro tubo Hose Size			Filetto Thread	Codolo Pipe	Dimensioni Dimensions (mm)		
	inch	mm	size	T		L	D	E
RTSF901415DIN	1/12"	2.1	-	M14x1.5	6	25	25	17
RTSF901615DIN	1/12"	2.1	-	M16x1.5	8	25	25	19
RTSF90181510DIN	1/12"	2.1	-	M18x1.5	10	42	40	22
RPF90DKOS1415DN3	1/8"	3.0	02	M14x1.5	6	39	25	17
RPF90DKOS1615DN3	1/8"	3.0	02	M16x1.5	8	41	36	19
RPF90DKOS1815DN3	1/8"	3.0	02	M18x1.5	10	47	40	22
RPF90DKOS1415486	5/32"	4.0	02.5	M14x1.5	6	39	25	17
RPF90DKOS1615488	5/32"	4.0	02.5	M16x1.5	8	46	36	19
RPF90DKOS18154810	5/32"	4.0	02.5	M18x1.5	10	47	40	22
RPF90DKOS20154812	5/32"	4.0	02.5	M20x1.5	12	47	40	24

RACCORDO OCCHIO BANJO FITTING

Materiale Material	Finitura superficiale Surface Finishing
Acciaio AVP Carbon Steel	Zincatura trivalente Zinc Plating

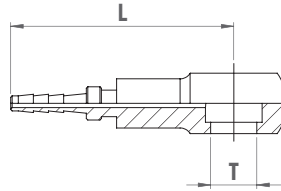

Codice Part Number	Diametro tubo Hose Size			Foro Hole	Dimensioni Dimensions (mm)	
	inch	mm	size		L	
OP8M112	1/12"	2.1	-	8	30	
OP18112	1/12"	2.1	-	1/8"	32	
OP10M112	1/12"	2.1	-	10	32	
OP8MDN3	1/8"	3.0	02	8	37	
OP18DN3	1/8"	3.0	02	1/8"	32	
OP10MDN3	1/8"	3.0	02	10	32	
OP8M48	5/32"	4.0	02.5	8	35	
OP1848	5/32"	4.0	02.5	1/8"	37	
OP10M48	5/32"	4.0	02.5	10	37	

RACCORDO OCCHIO A 90° 90° BANJO FITTING

Materiale Material	Finitura superficiale Surface Finishing
Acciaio AVP Carbon Steel	Zincatura trivalente Zinc Plating

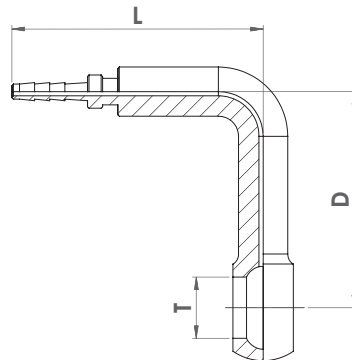

Codice Part Number	Diametro tubo Hose Size			Foro Hole	Dimensioni Dimensions (mm)	
	inch	mm	size		L	D
OP908M112	1/12"	2.1	-	8	36	26
OP9018112	1/12"	2.1	-	1/8"	34	36
OP908MDN3	1/8"	3.0	02	8	41	26
OP9018DN3	1/8"	3.0	02	1/8"	39	28
OP908M48	5/32"	4.0	02.5	8	41	26
OP901848	5/32"	4.0	02.5	1/8"	40	36

BULLONE FORATO BORED BOLT

Materiale Material	Finitura superficiale Surface Finishing
Acciaio AVP Carbon Steel	Zincatura trivalente Zinc Plating

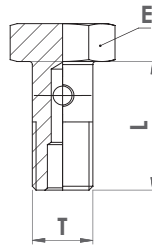

Codice Part Number	Filetto Thread	Dimensioni Dimensions (mm)	
		L	E
VC81	M8x1	17	12
VC101	M10x1	20	14
VC18	1/8"-28	18	14

FEMMINA ORFS O-RING FACE SEAL ORFS FEMALE O-RING FACE SEAL

Materiale Material	Finitura superficiale Surface Finishing
Acciaio AVP Carbon Steel	Zincatura trivalente Zinc Plating

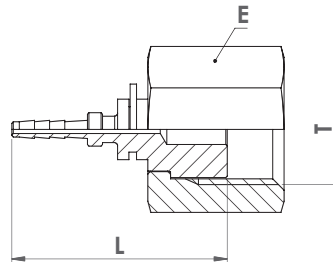

Codice Part Number	Diametro tubo Hose Size			Filetto Thread	Dimensioni Dimensions (mm)		
	inch	mm	size		T	L	E
RTSFD916ORFS	1/12"	2.1	-	9/16"-18	25		19
RTSFD1116ORFS	1/12"	2.1	-	11/16"-16	33		22
RPF916ORFSDN3	1/8"	3.0	02	9/16"-18	27		19
RPF1116ORFSDN3	1/8"	3.0	02	11/16"-16	35		22
RPF916ORFS48	5/32"	4.0	02.5	9/16"-18	31		19

FEMMINA 90° ORFS O-RING FACE SEAL 90° ORFS FEMALE O-RING FACE SEAL

Materiale Material	Finitura superficiale Surface Finishing
Acciaio AVP Carbon Steel	Zincatura trivalente Zinc Plating

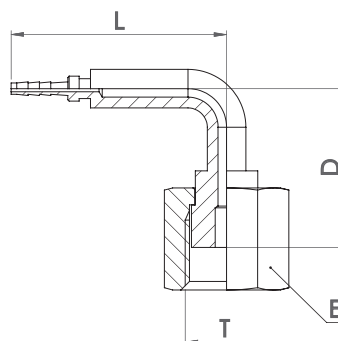

Codice Part Number	Diametro tubo Hose Size			Filetto Thread	Dimensioni Dimensions (mm)			
	inch	mm	size		T	L	D	E
RTSF90916ORFS	1/12"	2.1	-	9/16"-18	40	24		19
RPF90916ORFSDN3	1/8"	3.0	02	9/16"-18	40	24		19
RPF90916ORFS48	5/32"	4.0	02.5	9/16"-18	40	24		19

FEMMINA GIREVOLE A SPINA PER RACCORDO DI CONTROLLO CON ZIGRINATURA KNURLED SWIVEL PIN FEMALE TEST COUPLING FITTING

Materiale Material	Finitura superficiale Surface Finishing
Acciaio AVP Carbon Steel	Zincatura trivalente Zinc Plating

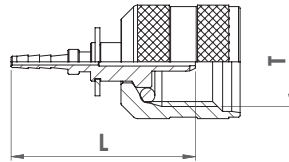

Codice Part Number	Diametro tubo Hose Size			Filetto Thread	Dimensioni Dimensions (mm)
	inch	mm	size	T	L
RTSFD162SPZ	1/12"	2.1	-	M16x2	33
RTSFD1615SPZ	1/12"	2.1	-	M16x1.5	33
RTSFD162SPZDN3	1/8"	3.0	02	M16x2	37
RTSFD1615SPZDN3	1/8"	3.0	02	M16x1.5	37
RTSFD162SPZ48	5/32"	4.0	02.5	M16x2	37
RTSFD1615SPZ48	5/32"	4.0	02.5	M16x1.5	37

FEMMINA GIREVOLE A SPINA PER RACCORDO DI CONTROLLO CON ESAGONO SWIVEL PIN FEMALE TEST COUPLING FITTING WITH HEXAGON

Materiale Material	Finitura superficiale Surface Finishing
Acciaio AVP Carbon Steel	Zincatura trivalente Zinc Plating

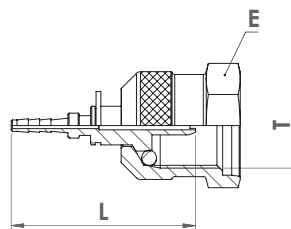

Codice Part Number	Diametro tubo Hose Size			Filetto Thread	Dimensioni Dimensions (mm)	
	inch	mm	size	T	L	E
RTSFD162SP	1/12"	2.1	-	M16x2	33	19
RTSFD1615SP	1/12"	2.1	-	M16x1.5	33	19
RTSFD162SPDN3	1/8"	3.0	02	M16x2	37	19
RTSFD1615SPDN3	1/8"	3.0	02	M16x1.5	37	19
RTSFD162SP48	5/32"	4.0	02.5	M16x2	37	19
RTSFD1615SP48	5/32"	4.0	02.5	M16x1.5	37	19

CODOLO LISCIO DIRITTO STRAIGHT STANDPIPE

Materiale Material	Finitura superficiale Surface Finishing
Acciaio AVP Carbon Steel	Zincatura trivalente Zinc Plating

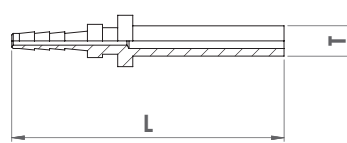

Codice Part Number	Diametro tubo Hose Size			Codolo Pipe	Dimensioni Dimensions (mm)
	inch	mm	size	T	L
RTSEP4	1/12"	2.1	-	4	36
RTSEP6	1/12"	2.1	-	6	35
RTSEP8	1/12"	2.1	-	8	35
EP4DN3	1/8"	3.0	02	4	41
EP6DN3	1/8"	3.0	02	6	36
EP8DN3	1/8"	3.0	02	8	38
EP448	5/32"	4.0	02.5	4	44
EP648	5/32"	4.0	02.5	6	46
EP848	5/32"	4.0	02.5	8	41

CODOLO LISCIO A 90° ELBOW 90° STANDPIPE

Materiale Material	Finitura superficiale Surface Finishing
Acciaio AVP Carbon Steel	Zincatura trivalente Zinc Plating

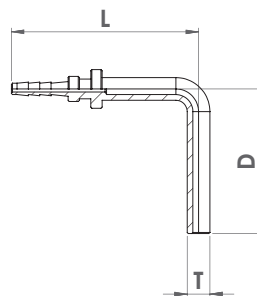

Codice Part Number	Diametro tubo Hose Size			Codolo Pipe	Dimensioni Dimensions (mm)	
	inch	mm	size	T	L	D
RTSEP904	1/12"	2.1	-	4	25	28
RTSEP906	1/12"	2.1	-	6	25	28
RTSEP908	1/12"	2.1	-	8	25	28
EP904DN3	1/8"	3.0	02	4	33	26
EP906DN3	1/8"	3.0	02	6	32	28
EP908DN3	1/8"	3.0	02	8	41	37
EP90448	5/32"	4.0	02.5	4	41	32
EP90648	5/32"	4.0	02.5	6	41	32
EP90848	5/32"	4.0	02.5	8	46	37

CODOLO LISCIO A 45° ELBOW 45° STANDPIPE

Materiale Material	Finitura superficiale Surface Finishing
Acciaio AVP Carbon Steel	Zincatura trivalente Zinc Plating

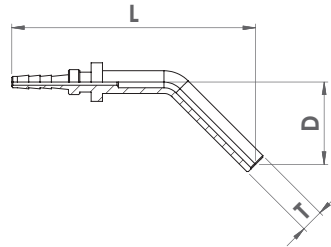

Codice Part Number	Diametro tubo Hose Size			Codolo Pipe	Dimensioni Dimensions (mm)	
	inch	mm	size		T	L
RTSEP454	1/12"	2.1	-	4	43	15
RTSEP456	1/12"	2.1	-	6	44	17
RTSEP458	1/12"	2.1	-	8	52	20
EP454DN3	1/8"	3.0	02	4	43	15
EP456DN3	1/8"	3.0	02	6	44	17
EP458DN3	1/8"	3.0	02	8	52	20
EP45448	5/32"	4.0	02.5	4	48	20
EP45648	5/32"	4.0	02.5	6	49	20
EP45848	5/32"	4.0	02.5	8	57	20

CAPPUCCIO PARAPOLVERE DUST PROTECTION CAP

Codice Part Number
RTSPARAPOLVERE

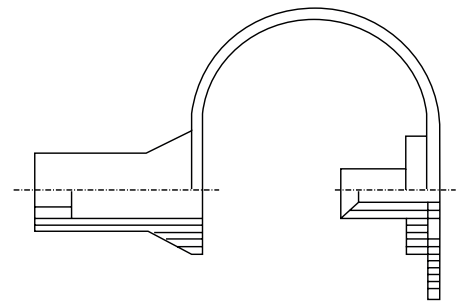

MINIPRESA M16X2 MASCHIO FILETTATURA CILINDRICA - TENUTA O-RING SOTTOTESTA
TEST COUPLING M16X2 MALE PARALLEL THREAD - UNDER HEAD O-RING SEALING

Materiale Material	Finitura superficiale Surface Finishing
Acciaio AVP Carbon Steel	Zincatura trivalente Zinc Plating

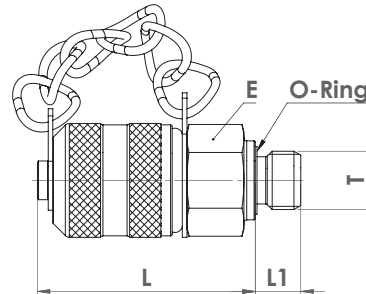

Codice Part Number	Filetto Thread	Dimensioni Dimensions (mm)			
		T	L	L1	E
RTSMM180R	1/8"-28		37	8	17
RTSMM140R	1/4"-19		37	12	19
RTSMM380R	3/8"-19		37	12	22
RTSMM120R	1/2"-14		37	14	27
RTSMM101SOR	M10x1		37	8	17
RTSMM12150R	M12x1.5		37	12	17
RTSMM14150R	M14x1.5		37	12	19

MINIPRESA M16X2 FEMMINA - TENUTA DKO 24° O-RING
TEST COUPLING M16X2 FEMALE - DKO 24° O-RING SEALING

Materiale Material	Finitura superficiale Surface Finishing
Acciaio AVP Carbon Steel	Zincatura trivalente Zinc Plating

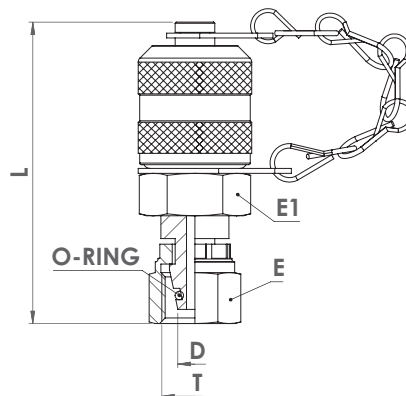

Codice Part Number	Filetto Thread	Tipo Type	Dimensioni Dimensions (mm)			
			D	L	E	E1
RTSMF12156DIN	M12x1.5	L	6	53	14	17
RTSMF14158DIN	M14x1.5	L	8	55	17	17
RTSMF161510DIN	M16x1.5	L	10	56	19	19
RTSMF181512DIN	M18x1.5	L	12	57	22	19
RTSMF221515DIN	M22x1,5	L	15	59	27	22
RTSMF261518DIN	M26x1.5	L	18	59	32	22
RTSMF30222DIN	M30x2	L	22	59	36	27
RTSMF14156DIN	M14x1.5	S	6	54	17	17
RTSMF16158DIN	M16x1.5	S	8	56	19	17
RTSMF181510DIN	M18x1.5	S	10	57	22	19
RTSMF201512DIN	M20x1.5	S	12	58	24	19
RTSMF241516DIN	M24x1.5	S	16	56	30	22
RTSMF30220DIN	M30x2	S	20	57	36	27

MINIPRESA M16X2 FEMMINA INTERMEDIA - TENUTA CEL-S 24°
TEST COUPLING M16X2 INTERMEDIATE FEMALE - CEL-S 24° SEALING

Materiale Material	Finitura superficiale Surface Finishing
Acciaio AVP Carbon Steel	Zincatura trivalente Zinc Plating

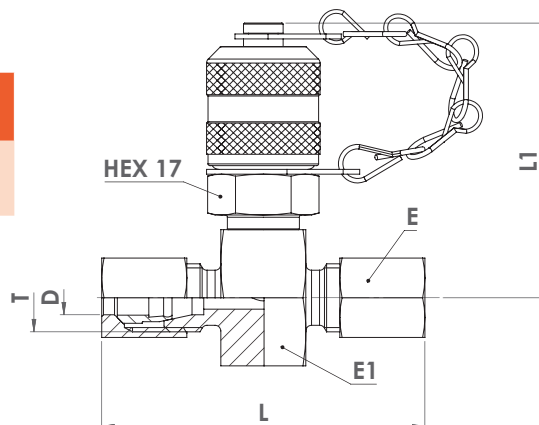

Codice Part Number	Filetto Thread	Tipo Type	Dimensioni Dimensions (mm)				
	T		D	L	L1	E	E1
RTSMFF12156DIN	M12x1.5	L	6	57	49	14	24
RTSMFF14158DIN	M14x1.5	L	8	51	49	17	24
RTSMFF161510DIN	M16x1.5	L	10	53	49	19	24
RTSMFF181512DIN	M18x1.5	L	12	53	49	22	24
RTSMFF221515DIN	M22x1.5	L	15	55	51	27	27
RTSMFF261518DIN	M26x1.5	L	18	57	53	32	32
RTSMFF30222DIN	M30x2	L	22	61	53	36	32
RTSMFF14156DIN	M14x1.5	S	6	55	49	17	24
RTSMFF16158DIN	M16x1.5	S	8	55	49	19	24
RTSMFF181510DIN	M18x1.5	S	10	57	49	22	24
RTSMFF201512DIN	M20x1.5	S	12	57	49	24	24
RTSMFF241516DIN	M24x1.5	S	16	63	52	30	27
RTSMFF30220DIN	M30x2	S	20	69	53	36	32

MINIPRESA M16X2 MASCHIO FILETTATURA CONICA - TENUTA SUL FILETTO
TEST COUPLING M16X2 MALE TAPER THREAD - THREAD SEALING

Materiale Material	Finitura superficiale Surface Finishing
Acciaio AVP Carbon Steel	Zincatura trivalente Zinc Plating

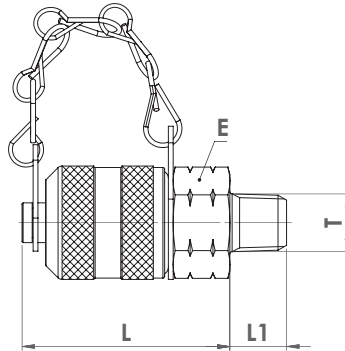

Codice Part Number	Filetto Thread		Dimensioni Dimensions (mm)		
	T		L	L1	E
RTSMMR18K	1/8"-28	R-ISO 7/1	37	10	17
RTSMMR14K	1/4"-19	R-ISO 7/1	37	12	19
RTSMMR38K	3/8"-19	R-ISO 7/1	37	14	22
RTSMM18NPT	1/8"-27	NPTF	37	10	17
RTSMM14NPT	1/4"-18	NPTF	37	17	17
RTSMM38NPT	3/8"-18	NPTF	37	16	22
RTSMM12NPT	1/2"-14	NPTF	37	17	24

MINIPRESA M16X2 MASCHIO FILETTATURA CILINDRICA - TENUTA O-RING RADIALE
TEST COUPLING M16X2 MALE PARALLEL THREAD - RADIAL O-RING SEALING

Materiale Material	Finitura superficiale Surface Finishing
Acciaio AVP Carbon Steel	Zincatura trivalente Zinc Plating

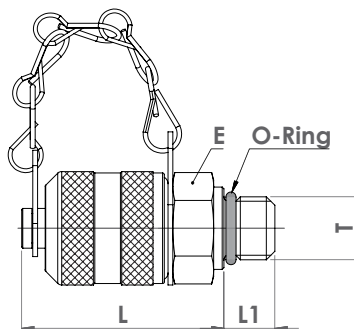

Codice Part Number	Filetto Thread		Dimensioni Dimensions (mm)		
	T		L	L1	E
RTSMM81OR	M8x1		37	8.5	17
RTSMM101OR	M10x1		37	8.5	17
RTSMM716OR	7/16"-20		37	9	17
RTSMM120RU	1/2"-20		37	10	17
RTSMM916OR	9/16"-18		37	10	19

MINIPRESA M16X2 CODOLO LISCIO TEST COUPLING M16X2 STANDPIPE

Materiale Material	Finitura superficiale Surface Finishing
Acciaio AVP Carbon Steel	Zincatura trivalente Zinc Plating

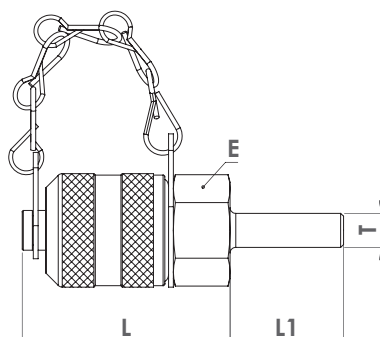

Codice Part Number	Codolo Pipe	Dimensioni Dimensions (mm)		
		L	L1	E
RTSME6	6	37	20	17
RTSME8	8	37	20	17
RTSME10	10	37	20	17
RTSME12	12	37	20	17
RTSME14	14	37	20	17
RTSME15	15	37	20	17
RTSME16	16	37	20	17

NIPLES PER COLLEGAMENTO MANOMETRO M16X2 NIPPLE FOR PRESSURE GAUGE CONNECTION M16X2

Materiale Material	Finitura superficiale Surface Finishing
Acciaio AVP Carbon Steel	Zincatura trivalente Zinc Plating

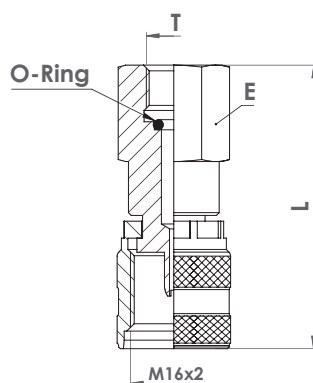

Codice Part Number	Filetto Thread	Dimensioni Dimensions (mm)		
		T	L	E
RTSN14	1/4"-19		50	19
RTSN12	1/2"-14		55	27
RTSN1418NPTF	1/4"-18		50	19

ACCESSORI

SPIRALI DI PROTEZIONE / PROTECTION SPIRALS

Accessorio per montaggio spirali / Confezione / Packaging Assembly Kit



Specifiche tecniche:

- Realizzate in polietilene ad alta densità
- Pratiche, rapide e semplici nel montaggio
- Indicate per la protezione o il contenimento di uno o più tubi
- Eccellente resistenza alle crepe da stress ambientali
- Resistenti ai raggi UV e all'abrasione
- Chimicamente compatibili con la maggior parte degli oli, polioli, emulsioni e solventi

Technical Features:

- Made of high-density polyethylene
- Practical, quick and simple to fit
- Suitable for protection or bundling of one or more hoses
- Excellent for environmental stress crack resistance
- UV and abrasion resistant
- Chemically compatible with most oils, polyols, emulsions and solvents

Temperatura di esercizio:

- Da -50°C a +100°C
- Da -58°F a +212°F

Working temperature:

- From -50°C to +100°C
- From -58°F to +212°F

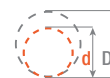

Codice articolo Article Code	Diametro Interno Internal Diameter	Diametro Esterno Outside Diameter	Spessore medio Wall Thickness	Larghezza bandella Strip width	Peso Weight	Diametri dei tubi Hose diameter range	Pezatura Length
	mm	mm	mm	mm	g/m	mm	m
GS0907	7	9	1.0	6.5	22	8÷10	150
GS128	9.5	12	1.7	10	46	10÷17	50
GS1612	12.5	16	1.8	12	76	13÷22	50
GS2016	16	20	1.8	14.5	86	16÷27	50
GS2520	21	25	2	21	112	21÷35	50
GS3227	27	32	2	24	177	27÷44	50
GS4036	34	40	2.5	30	217	34÷55	50

ACCESSORIES

GUAINE TESSILI DI PROTEZIONE GT / GT TEXTILE PROTECTION SHEATHS



Codice articolo Article Code	Larghezza Width	Diametro Diameter	Peso Weight	Pezatura Lenght
	mm	mm	g/m	mt
GT35	35	20	27	100
GT40	40	22	32	100
GT45	45	25	34	100
GT50	50	28	38	100
GT55	55	32	42	100
GT60	60	35	45	100
GT65	65	38	48	100
GT80	80	45	60	100

COLORE: ■ NERO* standard.

Altri colori disponibili su richiesta*

R = Rosso G = Giallo
B = Blu V = Verde

OPZIONI*:

- Marcatura personalizzata
- Certificazione MSHA IC332-08

*quantitativi minimi richiesti

COLOUR: ■ BLACK* standard.

Other colours available on request*

R = Red G = Yellow
B = Blue V = Green

OPTIONS*:

- Customized branding
- MSHA IC332-08 certification

*minimum order quantities required

Caratteristiche Tecniche:

- adatte per la protezione o il raggruppamento di uno o più tubi
- schermatura contro i getti d'olio e contenimento dell'olio secondo ISO 3457
- realizzate in fibra di poliestere ad alta tenacità
- ottima resistenza all'abrasione e alle sollecitazioni meccaniche
- ottima resistenza al calore e bassa conducibilità termica
- adatte per applicazioni in esterno grazie all'ottima resistenza ai raggi UV e agli agenti climatici
- chimicamente compatibili con una vasta gamma di oli, prodotti organici e solventi

Temperature di esercizio:

- Da -40°C a +100°C
- Da -40°F a +212°F

Technical Features:

- suitable for protection or bundling of one or more hoses
- burst shielding against oil jets and oil containment according to ISO 3457
- made of high-tenacity polyester fiber
- excellent resistance against abrasion and mechanical stress
- excellent heat resistance and low thermal conductivity
- suitable for outdoor applications thanks to excellent resistance against UV rays and climatic agents
- chemically compatible with a huge range of oils and organic products and solvents

Working Temperature:

- From -40°C to +100°C
- From -40°F to +212°F

PINZE TAGLIA TUBO / HOSE AND TUBING CUTTER



Codice / Part Nr.	Descrizione / Description
PZG1	Pinza in grado di tagliare tubi di diametro esterno massimo sino a 28.0 mm. / Cutter for tubing and textile braided hoses with OD max 28mm.
PZP1	Pinza in grado di tagliare tubi di diametro esterno massimo sino a 12 mm. / Cutter for tubing and textile braided hoses with OD max 12mm.
LMG1	Lame di ricambio per tagliatubo PZG1. / Replacement blades for hose Cutter PZG1.
LMP1	Lame di ricambio per tagliatubo PZP1. / Replacement blades for hose Cutter PZP1.

ACCESSORI

PRESSE MANUALI E PNEUMATICHE / MANUAL AND PNEUMATIC CRIMPING MACHINES



PRESSA MANUALE PMZ47 / MANUAL PRESS PMZ47



PRESSA PNEUMATICA PPZ47 / PNEUMATIC PRESS PPZ47

DATI TECNICI / TECHNICAL DATA	CODICE / CODE	
	PMZ47	PPZ47
FORZA DI PRESSATURA / CRIMPING FORCE	100 TONS (110 US TONS)	100 TONS (110 US TONS)
CAPACITÀ / CAPACITY UP TO	1"	1"
Ø MASSIMO / MAX Ø	46 mm* (1.811")	46 mm* (1.811")
APERTURA MORSETTI / DIE OPENING	Ø + 20 mm (Ø + 0.788")	Ø + 20 mm (Ø + 0.788")
RACCORDI A 90° / 90° FITTINGS UP TO	3/8"	3/8"
DIMENSIONI PRESSA LxPxH / DIMENSIONS LxWxH	390x510x300 mm (15.3"x20.7"x11.8")	380x430x400 mm (14.9"x16.9"x15.7")
PESO / WEIGHT	32 kg (71 Lbs)	38 kg (84 Lbs)
SFORZO SULLA LEVA / REQUIRED FORCE ON THE LEVER	30 kg (66 Lbs)	-
ALIMENTAZIONE PNEUMATICA / PNEUMATIC POWER SUPPLY	-	max 7 bar (100 Psi)
CILINDRO / CYLINDER	SEMPLICE EFFETTO / SINGLE ACTING	SEMPLICE EFFETTO / SINGLE ACTING
ACCESSORI INCLUSI / INCLUDED ACCESSORIES		



CASSETTO PORTA MORSETTI / DIE HOLDER BOX

OLIO 2,5 LT. (per PRESSA PNEUMATICA) / 2,5 LT. OIL (for PNEUMATIC PRESS)

MORSETTI / DIES#	PMZ47 - PPZ47										
 DIAMETRO MORSETTI / DIE SET DIAMETER	6	8	10	12	14	16	19	22	25	29	39*
 LUNGHEZZA MORSETTI / DIE LENGTH	55	55	55	55	55	55	55	55	65	65	64
CODICE / PART N. MPRESSA-	PPZ476	PPZ478	PPZ4710	PPZ4712	PPZ4714	PPZ4716	PPZ4719	PPZ4722	PPZ4725	PPZ4729	-

*Porta morsetti - Die holder

#Un diametro di morsetti a scelta compreso nella fornitura della pressa - One die set chosen by customer included with the press

ACCESSORI / OPTIONAL



UTENSILE CAMBIO MORSETTI / TOOL FOR DIE CHANGE
Part. N.: MPZ47UCM

ACCESSORIES

TAPPI DI SERVIZIO / SERVICE PLUGS



SERVICE PLUG è un innovativo sistema per operazioni di manutenzione, evita la fuoriuscita di fluidi e la contaminazione dei tubi durante le operazioni di manutenzione.

SERVICE PLUG is an innovative system for maintenance operations, preventing fluids leakage and contamination of hoses and systems during maintenance operations.

Caratteristiche

- Temperatura di esercizio: da -25° C a +90° C
- Resistente ai maggiori oli e sostanze chimiche
- Per sistemi non pressurizzati
- Non contengono silicone
- I tappi sono solidi, ma è possibile tagliarli se necessario
- Sono riutilizzabili

Features

- Temperature range: -25° C to +90° C
- Resistant to most oils and chemicals
- For non-pressurised systems only
- Does not contain silicone
- Plugs are solid but can be cut if necessary
- Reusable

Tappo Plug	MICRO
Diametro tubo Hose diameter	Ø from 1 to 10 mm



Descrizione Description	20 MICRO
Codice / Code	TAPPOSPMICRO

20x 

Istruzioni / Instructions

1. Inserire / Insert



2. Spingere / Push



3. Spingere e girare / Push and Twist



INDICAZIONI DI MONTAGGIO

INSTALLATION INSTRUCTIONS (SAE J1273 - ISO 8331)

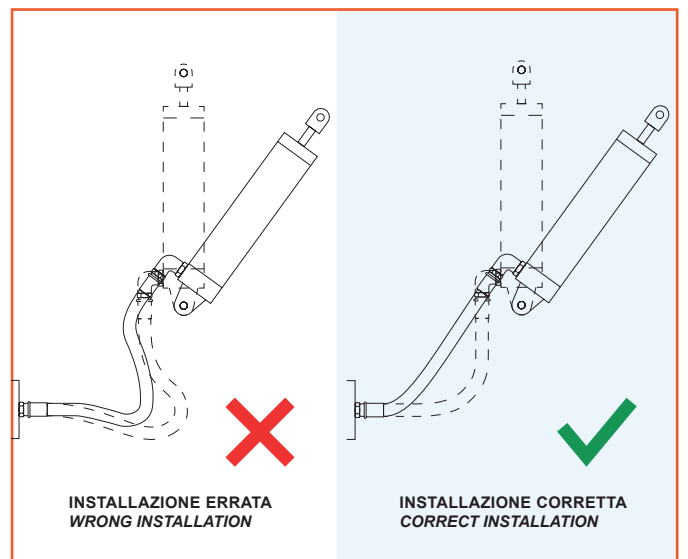
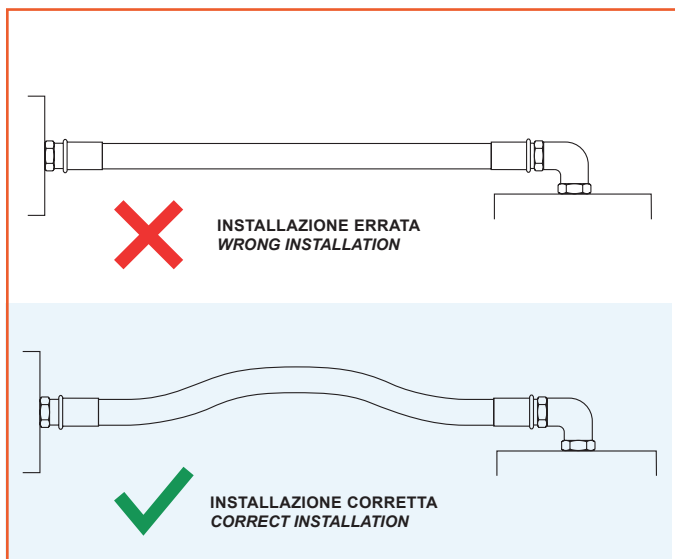
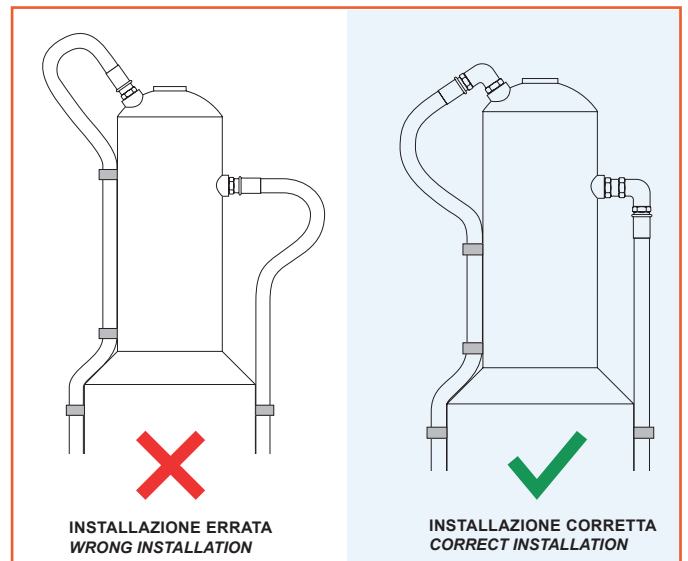
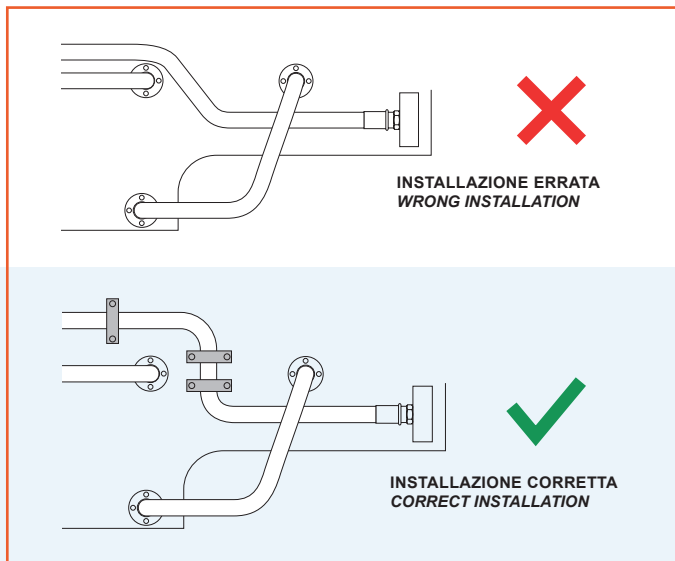
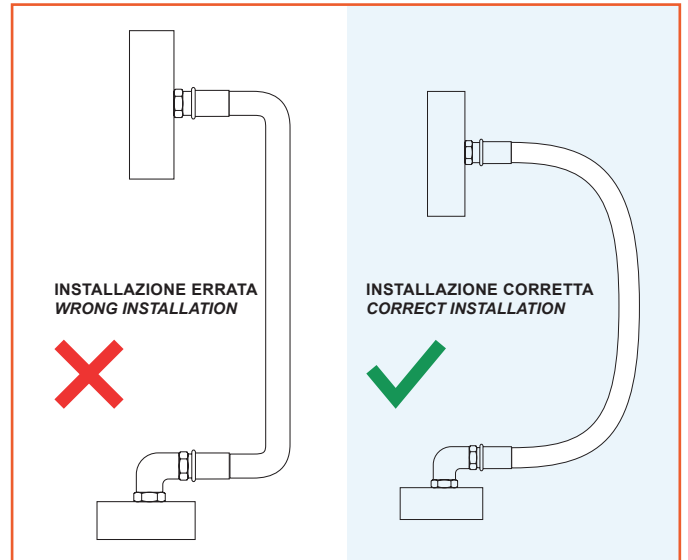
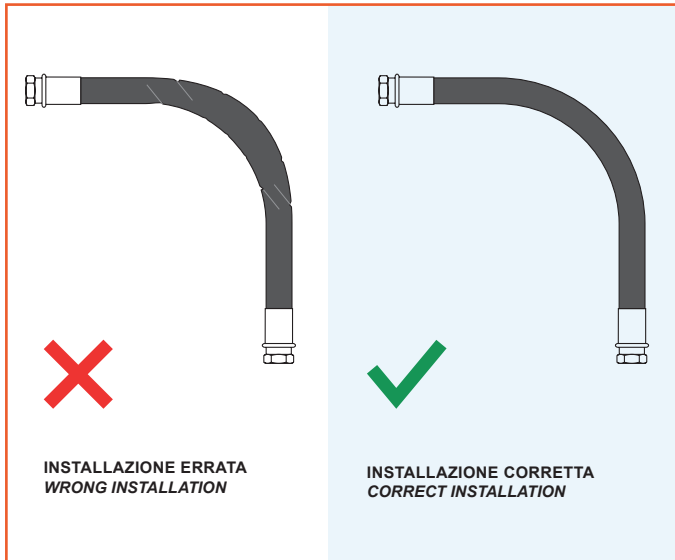

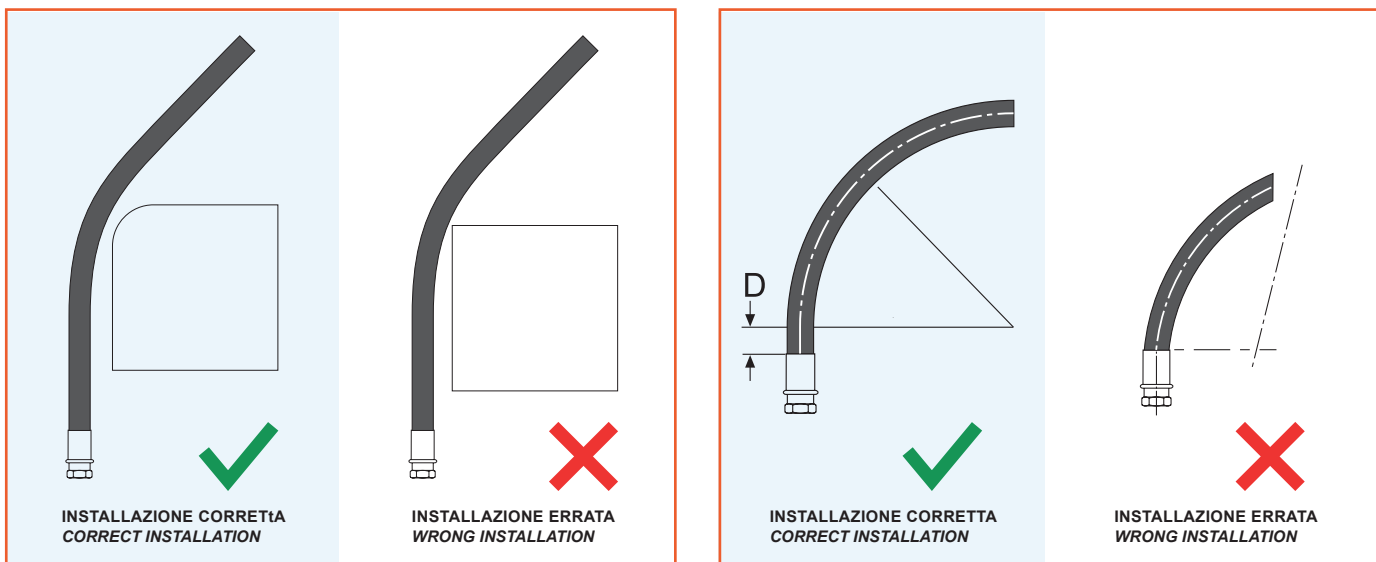

ISTRUZIONI E DATI DI RACCORDATURA CRIMPING DATA AND INSTRUCTIONS

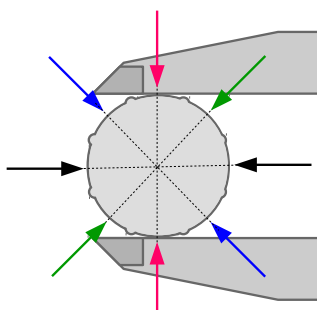

Per una corretta e sicura operazione di raccordatura raccomandiamo l'uso di raccordi e boccole ZEC; istruzioni e diametri di pressatura sono disponibili e sempre aggiornati in Area Riservata sul sito ZEC: www.zecspa.com/it/area-riservata

For a correct and safe crimping operation, we recommend the use of ZEC ferrules and fittings; proper instructions and crimping diameters are available and always updated into Restricted Area on ZEC's web page: www.zecspa.com/en/reserved-area

Le immagini e i valori menzionati in questo documento sono forniti a titolo puramente indicativo al fine di consentire una prima valutazione sulle possibilità di impiego dei prodotti. La Nostra produzione potrà essere variata senza impegno di alcun preavviso alla Nostra clientela.

Si raccomanda di verificare sul sito www.zecspa.com la presenza di possibili adeguamenti per scaricare le schede tecniche di prodotto aggiornate.

È responsabilità del cliente verificare che i tubi e i raccordi siano adatti alla propria applicazione e soddisfino le specifiche e gli standard richiesti.

Per condizioni di vendita: www.zecspa.com/it/condizioni-general-di-vendita

The images and values indicated in the present document are to be intended only as an indication, with the purpose of permitting the customer a first evaluation of the products application possibilities. Our production can be modified without any obligation of prior notice to our customers.

Therefore we recommend to consult our website www.zecspa.com for the latest version of the technical data sheets.

It's the Customer's responsibility to check that hoses and fittings are suitable for his application and meet the required specifications and standards.

For Terms of Sale please refer to www.zecspa.com/en/general-conditions-of-sale

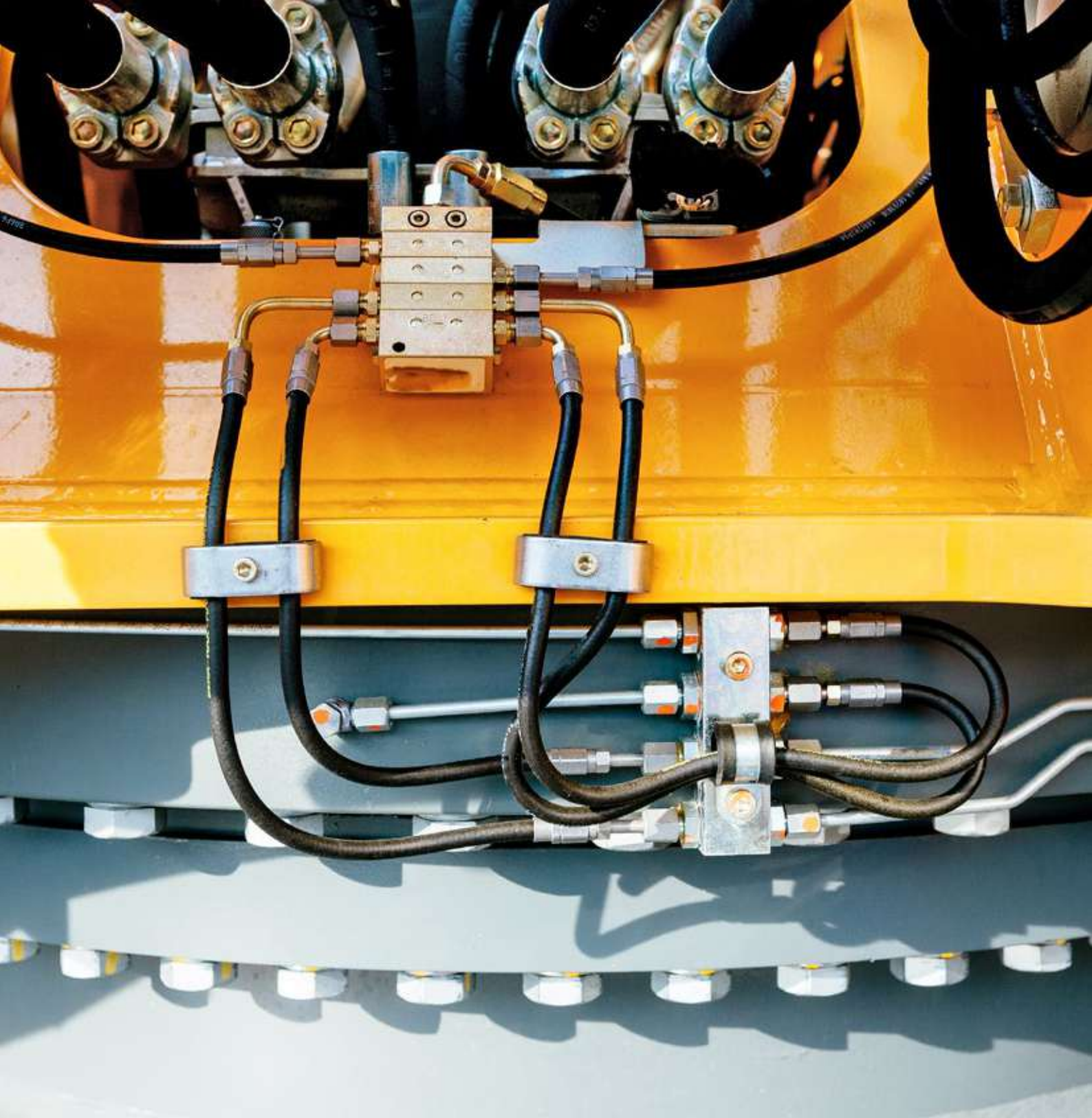

ZEC S.p.A.
Via Lungolorno 11, 43052 Colorno (PR) - Italy
Tel. +39 0521 816631 - Fax +039 0521 816772

www.zecspa.com
info@zecspa.com



THERMOPLASTIC TUBING AND HOSES



LubeTeam Hydraulic S.r.l.

Administration and Headquarter:

Via Tufara Scautieri, 6

83018 - San Martino Valle Caudina (AV)

Office and Warehouse:

S.S. 7 Appia, Km. 237,00

82011 - Airola BN

ITALY

Tel. +39 0823 950 994

Fax +39 0823 412 546

www.lubeteam.it info@lubeteam.it

Italian VAT / C.F. e P.IVA: 01251720627

Follow us



This document is the property of LubeTeam Hydraulic S.r.l. All data reported here are for the exclusive use of the Receiver. Reproduction is not authorized without writing permission, in all or in part of the content of this document, in accordance to Law 633 art. 171, dated April 22, 1941.

Il presente documento è di proprietà della LubeTeam Hydraulic S.r.l. I dati riportati sono per esclusivo del destinatario. La riproduzione, di tutto o in parte, non è autorizzata senza permesso scritto secondo l'art. 171 della L. 633 del 22 Aprile 1941.