

OLEODINAMICA GECO

Motori orbitali

Serie OFM



 HYDRAULIC  
COMPONENTS  
& FLUID CONTAMINATION  
CONTROL



All trademarks belong to their respective owners; third party trademarks, product names, trade names, corporate names and company names mentioned may be trademarks of their respective owners or registered trademarks of other companies and are used for instructional purposes and for the benefit of the owner, without any end of Copyright infringement in force.

Tutti i marchi riportati appartengono ai legittimi proprietari; marchi di terzi, nomi di prodotti, nomi commerciali, nomi corporativi e società citati possono essere di proprietà dei rispettivi titolari o registrati da altre società e sono stati utilizzati a puro scopo esplicativo e a beneficio del possessore, senza alcun fine di violazione dei diritti di Copyright vigenti.



**Motore a distribuzione lineare  
e albero a sostentamento  
idrodinamico**  
*Spool valve motor and  
hydrodynamic slide bearing  
supported shaft*

Albero scanalato B17 x 14 DIN 5482  
Splined shaft B17 x 14 DIN 5482

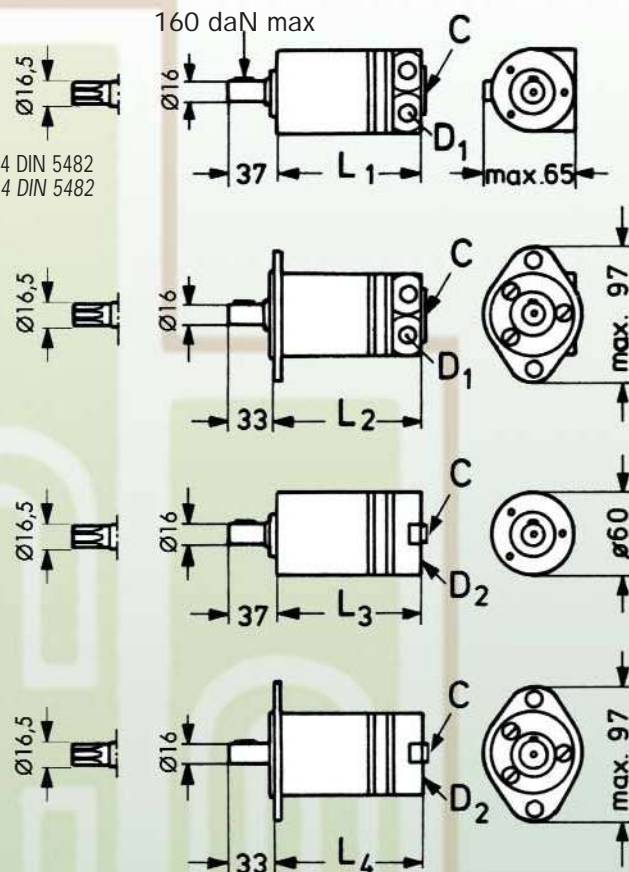

C : connessioni di drenaggio: G1/8  
*drain ports: G1/8*

D<sub>1</sub>: connessioni laterali: G3/8  
*side ports: G3/8*

D<sub>2</sub>: connessioni posteriori: G3/8  
*back ports: G3/8*

		OFM 8	OFM 12,5	OFM 20	OFM 32	OFM 50
Cilindrata / <i>Displacement (cm<sup>3</sup>)</i>		8,2	12,9	20	31,8	50
Velocità max (RPM)	cont.	1950	1550	1000	630	400
Max speed (RPM)	int.	2440	1940	1250	790	500
Coppia max (daNm)	cont.	1,1	1,6	2,5	4	4,5
Max torque (daNm)	int.	1,5	2,3	3,5	5,7	8
Potenza max (kW)	cont.	1,8	2,4	2,4	2,4	1,7
Max output (kW)	int.	2,6	3,2	3,2	3,2	2,1
Caduta pressione max (bar)	cont.	130	130	130	130	100
Max pressure drop (bar)	int.	150	150	150	150	140
Portata max (l/min)	cont.	16	20	20	20	20
Max oil flow (l/min)	int.	20	25	25	25	25
L <sub>1</sub> (mm)		109	111	114	119	122,5
L <sub>2</sub> (mm)		112,5	114,5	117,5	122,5	126
L <sub>3</sub> (mm)		104	106	109	114	121,5
L <sub>4</sub> (mm)		107,5	109,5	115,5	117,5	125





## LubeTeam Hydraulic S.r.l.

*Administration and Headquarter:*

Via Tufara Scautieri, 6  
83018 - San Martino Valle Caudina (AV)

*Office and Warehouse:*

S.S. 7 Appia, Km. 237,00

82011 - Airola BN

ITALY

Tel. +39 0823 950 994

Fax +39 0823 412 546

[www.lubeteam.it](http://www.lubeteam.it) [info@lubeteam.it](mailto:info@lubeteam.it)

Italian VAT / C.F. e P.IVA: 01251720627

Follow us



This document is the property of LubeTeam Hydraulic S.r.l. All data reported here are for the exclusive use of the Receiver. Reproduction is not authorized without writing permission, in all or in part of the content of this document, in accordance to Law 633 art. 171, dated April 22, 1941.

Il presente documento è di proprietà della LubeTeam Hydraulic S.r.l. I dati riportati sono per esclusivo del destinatario. La riproduzione, di tutto o in parte, non è autorizzata senza permesso scritto secondo l'art. 171 della L. 633 del 22 Aprile 1941.