

Tierre
Serie XVR
Innesti rapidi



 HYDRAULIC
COMPONENTS
& FLUID CONTAMINATION
CONTROL



All trademarks belong to their respective owners; third party trademarks, product names, trade names, corporate names and company names mentioned may be trademarks of their respective owners or registered trademarks of other companies and are used for instructional purposes and for the benefit of the owner, without any end of Copyright infringement in force.

Tutti i marchi riportati appartengono ai legittimi proprietari; marchi di terzi, nomi di prodotti, nomi commerciali, nomi corporativi e società citati possono essere di proprietà dei rispettivi titolari o registrati da altre società e sono stati utilizzati a puro scopo esplicativo e a beneficio del possessore, senza alcun fine di violazione dei diritti di Copyright vigenti.

 **TierreFittings**[®]

SERIE XVR

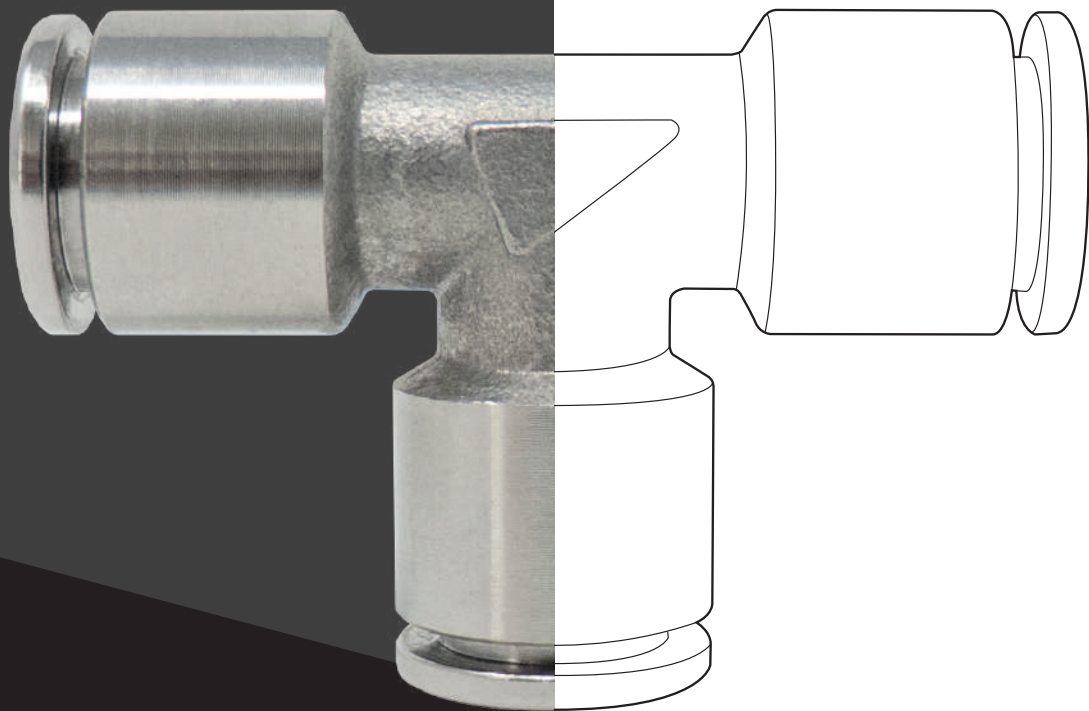

 **TierreGroup**[®]





 **TierreGroup**[®]

 **TierreFittings**[®]

 **F-Line**[®].PRO

 **NET.Fit**[®]

 **INOX.Fit**[®]



SERIE XVR INOX AISI 316L



PLUS

Adatti per essere utilizzati in **AMBIENTI AGGRESSIVI** e in **CONDIZIONI D'IMPIEGO CRITICHE**

Adatti per **APPLICAZIONI A CONTATTO CON ALIMENTI**

DESIGN OTTIMIZZATO DALLE DIMENSIONI COMPATTE

Possibilità di sviluppo di **PRODOTTI PERSONALIZZATI SU SPECIFICA RICHIESTA**



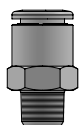

p. 8 / **XVRC-R**



p. 8 / **XVRC-G**



p. 8 / **XVROC-G**

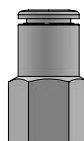

p. 9 / **XVRCF-G**

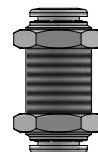

p. 9 / **XVRMM**

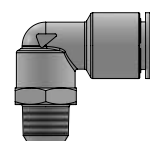

p. 9 / **XVRL-R**

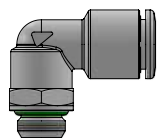

p. 10 / **XVRL-G**

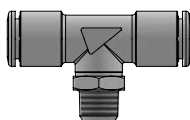

p. 10 / **XVRT-R**

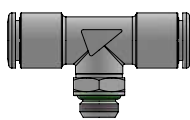

p. 10 / **XVRT-G**

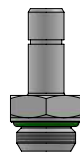

p. 11 / **XVRA-G**



p. 11 / **XVRUC**

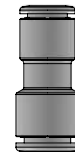

p. 11 / **XVRG**

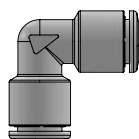

p. 12 / **XVRUL**

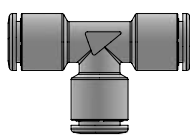

p. 12 / **XVRUT**



p. 12 / **XVRGJ**



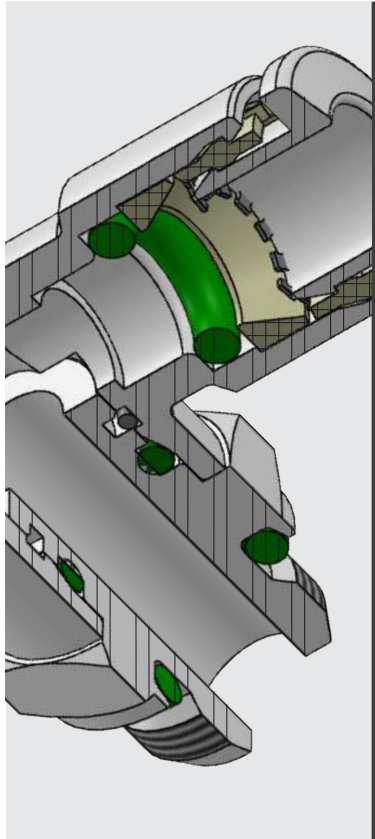

-20°C ÷ 150°C



Pressione d'esercizio:

20 Bar

Pressione negativa:

- 0,95 Bar (- 99 Kpa)



Aria compressa, vuoto, acqua e fluidi adatti con i materiali costruttivi



- Conica gas BSPT ISO 7
R1/8" - R1/2"

- Cilindrica gas BSPP ISO 228
G1/8" - G1/2"

- Metrica ISO 262
M5 - M7



Tubo in poliammide PA,
polietilene PE, FEP, PTFE e
inox con scanalatura (vedi
tabella)

Corpo: Acciaio inox AISI 316L

Colletto: Acciaio inox AISI 316L

Distanziale: PVDF-UHM conforme alla direttiva FDA

O-ring: FKM certificato NSF/ANSI 61 conforme alla direttiva FDA

Guarnizione: FKM certificato NSF/ANSI 61 conforme alla direttiva FDA

Pinza: Acciaio inox AISI 301

Collare: PVDF-UHM conforme alla direttiva FDA

Anello di sgancio per sistemi girevoli: Acciaio inox AISI 302



NSF/ANSI 169



MOCA
EC 1935/2004



D.M. 174/2004



Prodotto certificato ICIM
materiali a contatto con
alimenti



Prodotto certificato ICIM
materiali a contatto con
acqua

SILICONE FREE



Prodotti conformi alla
direttiva 1907/2006



Prodotti conformi alla
direttiva EU 2015/863

UTILIZZO CON TUBI IN MATERIALI DURI

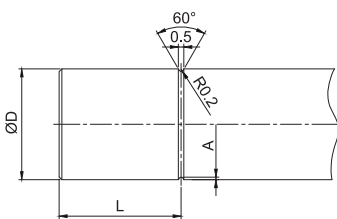

Qualora si utilizzino tubi metallici è necessario sbavare le parti terminali del tubo al fine di evitare tagli o altri danni agli o-ring.

ØD (mm)	L	A
4	7,6	0,23
6	8,0	0,23
8	9,0	0,23
10	11,0	0,23
12	12,7	0,23

DETTAGLI COSTRUTTIVI

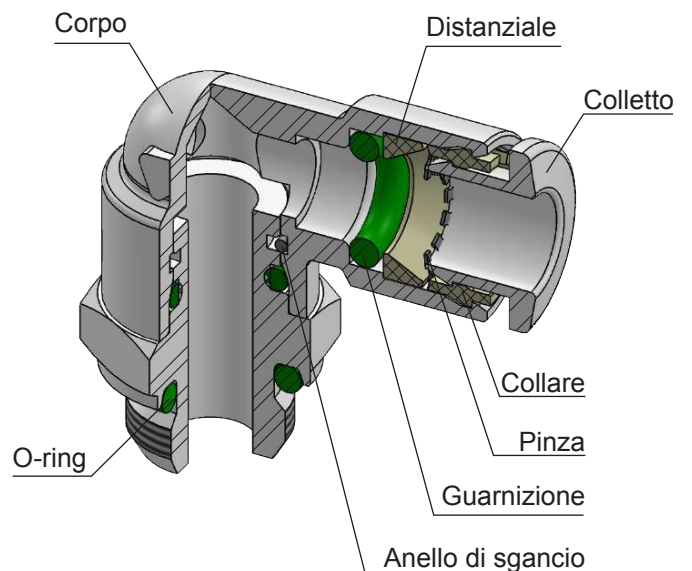

CONNESSIONE DEL TUBO AL RACCORDO

- Assicurarsi che il tubo sia sempre inserito completamente fino a battuta.
- Tagliare il tubo a 90° mediante l'utilizzo di un apposito cutter, inserirlo fino a battuta e tirarlo con accortezza per accertare il corretto inserimento.
- Se ci sono danni o imperfezioni sulla superficie del tubo o se lo stesso risulta ovalizzato si possono verificare delle perdite d'aria od una imprevista disconnessione. Verificare il tutto scrupolosamente.
- Il diametro esterno del tubo in poliuretano si espande in base alla pressione applicata. Pertanto il reinserimento nel raccordo potrebbe non essere più possibile.
- Tagliare la parte di tubo agganciata al raccordo per poterlo riutilizzare.

DISCONNESSIONE DEL TUBO DAL RACCORDO

- Accertarsi che il tubo non sia in pressione prima di disconnettere lo stesso dal raccordo.
- Per sganciare il tubo premere l'anello di sgancio (1), tirare ed estrarre il tubo (2) contemporaneamente.
- Tagliare la parte di tubo agganciata al raccordo per poterlo riutilizzare.

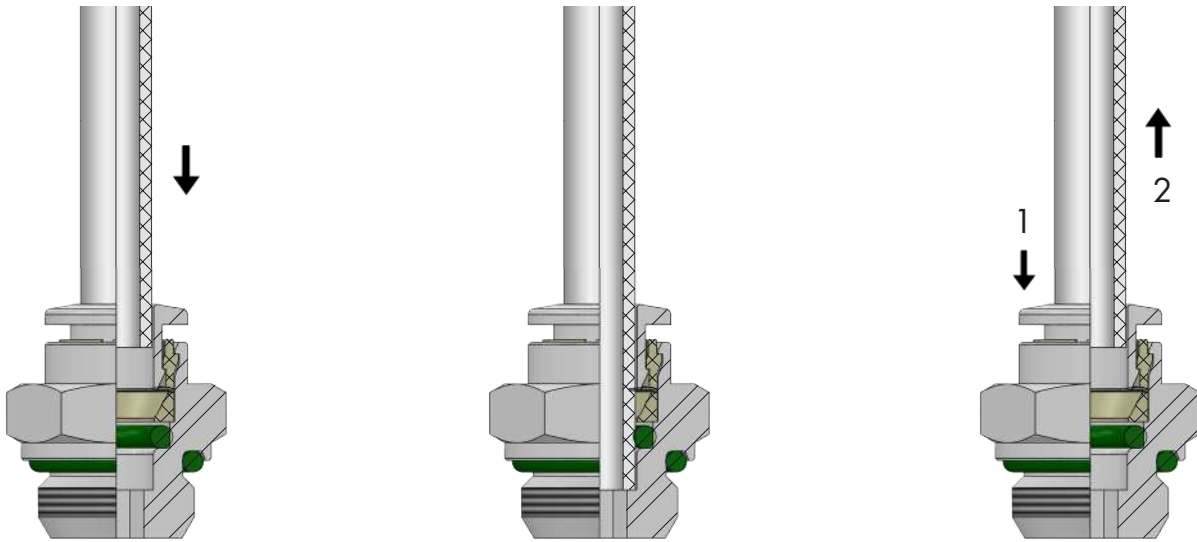

TOLLERANZA - TUBO METRICO

Ø TUBO (mm)	4	6	8	10	12
TOLLERANZA (mm)	± 0,1	± 0,1	± 0,1	± 0,15	± 0,15

INSERIMENTO - TUBO METRICO

Ø TUBO (mm)	4	6	8	10	12
LUNGHEZZA DI INSERIMENTO TUBO (mm)	14	15,5	17,5	19	21

COPPIA DI SERRAGGIO CONICA GAS BSPT ISO 7

FILETTO	1/8"	1/4"	3/8"	1/2"
Nm	2,5	3,5	6	12

COPPIA DI SERRAGGIO CILINDRICA GAS BSPP ISO 228 & METRICA ISO 262

FILETTO	M5x0,8	M7x1	1/8"	1/4"	3/8"	1/2"
Nm	0,8	0,8	1,2	1,5	2,5	3,5



XVRC-R

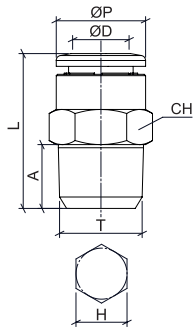
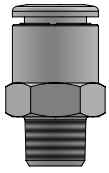

Diritto maschio conico BSPT

CODICE	ØD	T	ØP	A	L	CH	H
XVRC04R01	4	R 1/8"	10	8	18,5	10	3
XVRC04R02		R 1/4"	10	10	20	14	3
XVRC06R01	6	R 1/8"	12	8	21	12	4
XVRC06R02		R 1/4"	12	10	20,5	14	4
XVRC08R01	8	R 1/8"	14	8	26	14	5
XVRC08R02		R 1/4"	14	10	24	14	6
XVRC08R03		R 3/8"	14	11	22	17	6
XVRC10R02	10	R 1/4"	16	10	31	16	7
XVRC10R03		R 3/8"	16	11	26	17	8
XVRC12R02	12	R 1/4"	19	10	33	19	7
XVRC12R03		R 3/8"	19	11	29,5	19	10
XVRC12R04		R 1/2"	19	14	27	22	10

XVRC-G

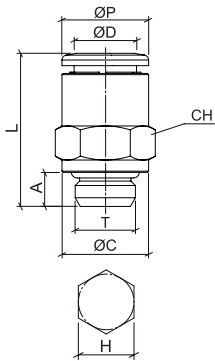
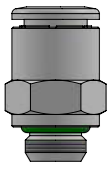

Diritto maschio cilindrico BSPP & metrico

CODICE	ØD	T	ØP	ØC	A	L	CH	H
XVRC04M5	4	M5x0,8	10	7	4	19	10	2,5
XVRC04G01		G 1/8"	10	13	5,5	18	13	3
XVRC04G02		G 1/4"	10	16	6,5	18	16	3
XVRC06M5	6	M5x0,8	12	7	5	21	12	2,5
XVRC06G01		G 1/8"	12	13	5,5	19,5	13	4
XVRC06G02		G 1/4"	12	16	6,5	19,5	16	4
XVRC08G01	8	G 1/8"	14	14	5,5	24,5	14	5
XVRC08G02		G 1/4"	14	16	6,5	21,5	16	6
XVRC08G03		G 3/8"	14	20	7,5	21,5	20	6
XVRC10G02	10	G 1/4"	16	16	6,5	27,5	16	7
XVRC10G03		G 3/8"	16	20	7,5	25	20	8
XVRC12G02	12	G 1/4"	19	16	6,5	30	19	7
XVRC12G03		G 3/8"	19	22	7,5	29,5	22	10
XVRC12G04		G 1/2"	19	25	9	28	25	10

XVROC-G

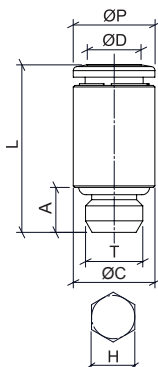

Diritto maschio tondo cilindrico BSPP & metrico

CODICE	ØD	T	ØP	ØC	A	L	H
XVROC04M5	4	M5x0,8	10	10	4	19	2,5
XVROC04M7		M7x1	10	10	5,5	20,5	2,5
XVROC06M7C	6	M7x1	10	10	5,5	20,5	4
XVROC06G01		G 1/8"	12	14	5,5	19,5	4
XVROC08G01	8	G 1/8"	14	14	5,5	24,5	5



XVRCF-G



Diritto femmina cilindrico BSPP

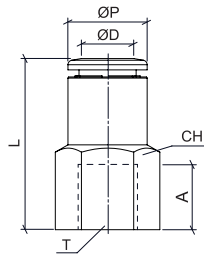
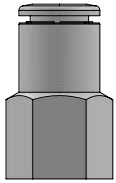

CODICE	ØD	T	ØP	A	L	CH
XVRCF04G01	4	G 1/8"	10	7,5	24,5	13
XVRCF06G01	6	G 1/8"	12	7,5	26	13
XVRCF08G02	8	G 1/4"	14	11	30	16

XVRMM



Passaparete

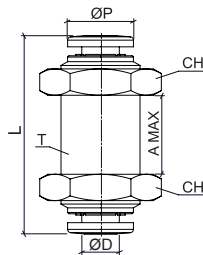
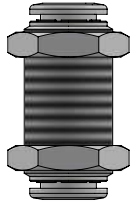

CODICE	ØD	T	ØP	A (MAX)	L	CH
XVRMM04	4	M12x1	10	12	30	16
XVRMM06	6	M14x1	12	15	35,5	17
XVRMM08	8	M16x1	14	16	36,5	19
XVRMM10	10	M20x1	16	19	43	24
XVRMM12	12	M22x1,5	19	20	44	25

XVRL-R



Gomito maschio girevole conico BSPT

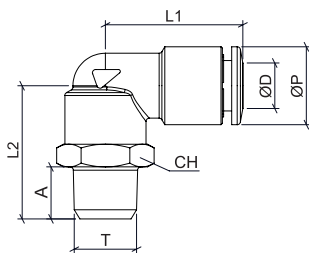
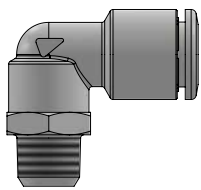

CODICE	ØD	T	ØP	A	L1	L2	CH
XVRL04R01	4	R 1/8"	10	8	19,5	20,5	13
XVRL04R02		R 1/4"	10	10	19,5	23	14
XVRL06R01	6	R 1/8"	12	8	21	20,5	13
XVRL06R02		R 1/4"	12	10	21	23	14
XVRL08R01	8	R 1/8"	14	8	23	20,5	14
XVRL08R02		R 1/4"	14	10	23	23	14
XVRL08R03		R 3/8"	14	11	23	24,5	17
XVRL10R02	10	R 1/4"	16	10	26	25,5	16
XVRL10R03		R 3/8"	16	11	26	27	17
XVRL12R02	12	R 1/4"	19	10	31	28	20
XVRL12R03		R 3/8"	19	11	31	28,5	20
XVRL12R04		R 1/2"	19	14	31	31,5	22



XVRL-G

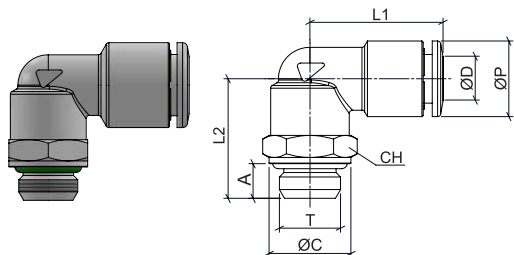

Gomito maschio girevole cilindrico BSPP & metrico

CODICE	ØD	T	ØP	ØC	A	L1	L2	CH
XVRL04M5	4	M5x0,8	10	7	4	18	16,5	8
XVRL04G01		G 1/8"	10	13	5,5	19,5	19	13
XVRL04G02		G 1/4"	10	16	6,5	19,5	21,5	16
XVRL06M5	6	M5x0,8	12	7	4	21	16,5	8
XVRL06G01		G 1/8"	12	13	5,5	21	19	13
XVRL06G02		G 1/4"	12	16	6,5	21	21	16
XVRL08G01	8	G 1/8"	14	13	5,5	23	19	13
XVRL08G02		G 1/4"	14	16	6,5	23	21	16
XVRL08G03		G 3/8"	14	20	7,5	23	23	20
XVRL10G02	10	G 1/4"	16	16	6,5	26	23	16
XVRL10G03		G 3/8"	16	20	7,5	26	26	20
XVRL12G02	12	G 1/4"	19	16	6,5	31	-	-
XVRL12G03		G 3/8"	19	20	7,5	31	29	20
XVRL12G04		G 1/2"	19	25	9	31	29	25

XVRT-R

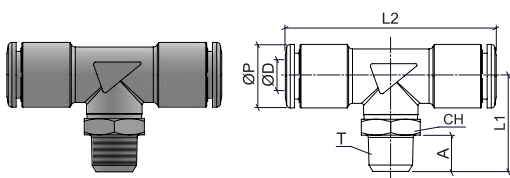

T centrale maschio girevole conico BSPT

CODICE	ØD	T	ØP	A	L1	L2	CH
XVRT04R01	4	R 1/8"	10	8	21	39	13
XVRT06R01	6	R 1/8"	12	8	21	42	13
XVRT06R02		R 1/4"	12	10	23,5	42	14
XVRT08R01	8	R 1/8"	14	8	21	46,5	13
XVRT08R02		R 1/4"	14	10	23,5	46,5	14

XVRT-G

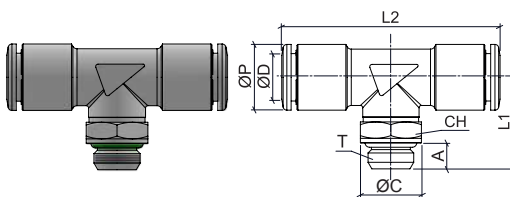

T centrale maschio girevole BSPP & metrico

CODICE	ØD	T	ØP	ØC	A	L1	L2	CH
XVRT04M5	4	M5x0,8	10	7	4	17	32	8
XVRT04G01		G 1/8"	10	13	5,5	19,5	39	13
XVRT06M5	6	M5x0,8	12	7	4	17	40	8
XVRT06G01		G 1/8"	12	13	5,5	19,5	42	13
XVRT06G02		G 1/4"	12	16	6,5	22	42	16
XVRT08G01	8	G 1/8"	14	13	5,5	19,5	46,5	13
XVRT08G02		G 1/4"	14	16	6,5	22	46,5	16
XVRT10G02	10	G 1/4"	16	16	6,5	23	52	16
XVRT10G03		G 3/8"	16	20	7,5	26	52	20
XVRT12G03	12	G 3/8"	19	20	7,5	26,5	62	20
XVRT12G04		G 1/2"	19	25	9	29	62	25



XVRA-G



Adattatore cilindrico BSPP

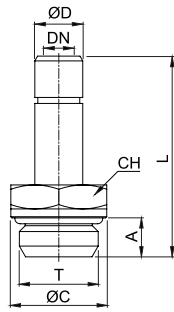
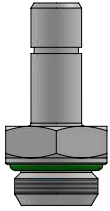

CODICE	ØD	T	ØC	A	L	DN	CH
XVRA04G01	4	G 1/8"	13	5,5	27,0	2	13
XVRA06G01	6	G 1/8"	13	5,5	28,0	4	13
XVRA06G02		G 1/4"	16	6,5	30,5	4	16
XVRA08G01	8	G 1/8"	13	5,5	29,5	6	13
XVRA08G02		G 1/4"	16	6,5	32,0	6	16
XVRA10G02	10	G 1/4"	16	6,5	36,5	8	16
XVRA12G03	12	G 3/8"	20	7,5	38,5	10	20

XVRUC



Intermedio diritto

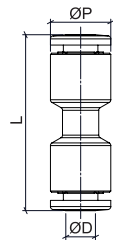
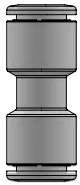

CODICE	ØD	ØP	L
XVRUC04	4	10	29
XVRUC06	6	12	32
XVRUC08	8	14	35,5
XVRUC10	10	16	39,5
XVRUC12	12	19	44

XVRG



Intermedio diritto ridotto

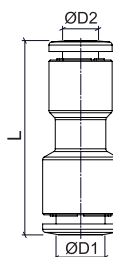
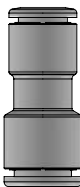

CODICE	ØD1	ØD2	L
XVRG0604	6	4	30,5
XVRG0806	8	6	34
XVRG1008	10	8	37
XVRG1210	12	10	41,5



XVRUL



Intermedio a gomito

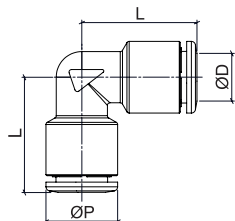
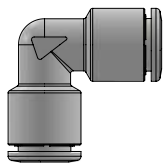

CODICE	ØD	ØP	L
XVRUL04	4	10	16,5
XVRUL06	6	12	20,5
XVRUL08	8	14	22,5
XVRUL10	10	16	25
XVRUL12	12	19	29

XVRUT



Intermedio a T

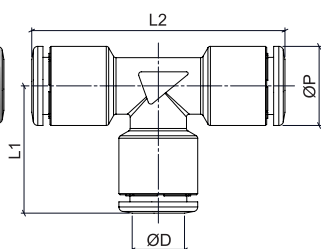
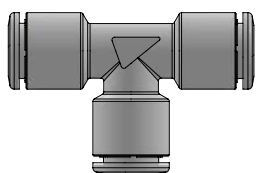

CODICE	ØD	ØP	L1	L2
XVRUT04	4	10	16,5	33
XVRUT06	6	12	20,5	41
XVRUT08	8	14	22,5	45
XVRUT10	10	16	25	50,5
XVRUT12	12	19	29	58

XVRGJ



Riduzione codolo tubo

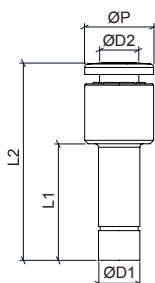
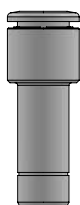

CODICE	ØD1	ØD2	ØP	L1	L2
XVRGJ0604	6	4	10	17	28,5
XVRGJ0806	8	6	12	19,5	32,5
XVRGJ1008	10	8	14	24	38





CERTIFICAZIONE NSF

NSF International

789 N. Dixboro Road, Ann Arbor, MI 48105 USA

RECOGNIZES

Tierre Group S.p.A.
Italy

AS COMPLYING WITH NSF/ANSI 169 AND ALL APPLICABLE REQUIREMENTS.
PRODUCTS APPEARING IN THE NSF OFFICIAL LISTING ARE
AUTHORIZED TO BEAR THE NSF MARK.



Certification Program
Accredited by the
American National
Standards Institute



Certification Program
Accredited by the
Standards Council
of Canada

This certificate is the property of NSF International and must be returned upon request. This certificate remains valid as long as this client has products in NSF's Official Listings for the referenced standards. For the most current and complete Listing information, please access NSF's website (www.nsf.org).

July 10, 2019
Certificate# C0484626 - 01

A handwritten signature in black ink, appearing to read "S Krol", written over a horizontal line.

Sarah Krol
Global Managing Director, Food Safety Product Certification



CERTIFICAZIONE MOCA - EC 1935/2004*

* Certificazione completa scaricabile dal nostro sito (www.tierrefittings.com) o su richiesta.



Tierre Group S.p.a.
 Sede: Via Dell'Industria 18 – 20032 Cormano (MI) – Italia
 Magazzino: Via Dell'Artigianato 2 – 20032 Cormano (MI) – Italia
 Produzione: Via Marco Biagi 1 – 25045 Castagnato (BS) – Italia
 C.F. e P.IVA IT 12437570158 – Cap. Soc. €120.000,00 i.v.
 REA MI-1558390



Tel. +39 02 663088.1 – Fax +39 02 66304172
www.tierregroup.com – info@tierregroup.com

DICHIARAZIONE DI CONFORMITA'
MOCA



Materiale e Oggetti a Contatto con Alimenti

TIERRE GROUP S.p.a.

DICHIARA

che gli articoli appartenenti alle seguenti gamme di prodotto:

FOOD GRADE SERIE HFR - *Raccordi ad innesto rapido in ottone con trattamento TEA⁺*

SERIE XVR INOX AISI 316 L - *Raccordi ad innesto rapido in acciaio inox AISI 316L*

SONO CONFORMI

Al regolamento **CE 1935/2004** del Parlamento Europeo e del Consiglio del 27 ottobre 2004 riguardante i materiali e gli oggetti destinati a venire a contatto con i prodotti alimentari e che abroga le direttive 80/590/CEE e 89/109/CEE

Al regolamento **CE 2023/2006** della Commissione, del 22 dicembre 2006, sulle buone pratiche di fabbricazione dei materiali e degli oggetti destinati a venire a contatto con prodotti alimentari.

Gli articoli delle suddette serie sono stati prodotti con i seguenti materiali:

FOOD GRADE SERIE HFR:

Ottone UNI EN 12164 CW 614 L - Ottone UNI EN 12164 CW 617 L
 Viton - EPDM (opzionale)
 Trattamento superficiale TEA⁺
 AISI 302

SERIE XVR INOX AISI 316 L:

AISI 316 L
 Viton - EPDM (opzionale)
 AISI 302



CERTIFICAZIONE D.M. 174/2004

* Certificazione completa scaricabile dal nostro sito (www.tierrefittings.com) o su richiesta.



Tierre Group S.p.a.
Sede: Via Dell'Industria 18 – 20032 Cormano (MI) – Italia
Magazzino: Via Dell'Artigianato 2 – 20032 Cormano (MI) – Italia
Produzione: Via Marco Biagi 1 – 25045 Castegnato (BS) – Italia
C.F. e P.IVA IT 12437570158 – Cap. Soc. €120.000,00 i.v.
REA MI-1558390



Tel. +39 02 663088.1 – Fax +39 02 66304172
www.tierregroup.com – info@tierregroup.com

**DICHIARAZIONE DI CONFORMITA'
D.M. 174/2004**



Regolamento concernente i materiali e gli oggetti che possono essere utilizzati negli impianti fissi di captazione, trattamento, adduzione e distribuzione delle acque destinate al consumo umano.

TIERRE GROUP S.p.a.

DICHIARA

che gli articoli appartenenti alle seguenti gamme di prodotto:

SERIE XVR INOX AISI 316 L - Raccordi ad innesto rapido in acciaio inox AISI 316 L

SONO CONFORMI

al Decreto 6 aprile 2004, n. 174 del Ministero della Salute. Regolamento concernente i materiali e gli oggetti che possono essere utilizzati negli impianti fissi di captazione, trattamento, adduzione e distribuzione delle acque destinate al consumo umano (G.U. n. 166 del 17-7-2004)

Gli articoli delle suddette serie sono stati prodotti con i seguenti materiali:

SERIE XVR INOX AISI 316 L:

AISI 316 L
Viton - EPDM (opzionale)
AISI 302



CERTIFICAZIONE ICIM: CONTATTO CON ALIMENTI (DISPOSIZIONI MOCA)

 <p>PRD N° 004 B</p> <p>Membro degli Accordi di Mutuo Riconoscimento EA, IAF e ILAC Signatory of EA, IAF and ILAC Mutual Recognition Agreements</p>		
<p>Certificazione di Prodotto <i>Product Certification</i></p>		
<hr/> <p>Certificato N. ICIM-MOC-009809-00 Certificate No.</p> <hr/>		
<p>ALL'AZIENDA / TO THE FIRM</p> <p>TIERRE GROUP S.P.A. Via dell'Industria, 18 – 20032 Cormano (MI) Italia</p> <hr/>		
<p>PER I SEGUENTI PRODOTTI / FOR THE FOLLOWING PRODUCTS</p> <p>Raccordi ad innesto rapido in acciaio inox AISI 316L. Raccordi ad innesto rapido in ottone con trattamento T.E.A. AISI 316L stainless steel push-in fittings. Brass push-in fittings with T.E.A. plating</p> <hr/>		
<p>CON DENOMINAZIONE COMMERCIALE / WITH TRADE NAME/S</p> <p>Serie XVR INOX AISI 316L / XVR SERIES INOX AISI 316L Food grade serie HFR / Food grade HFR SERIES</p>		
<p><small>(Utilizzo limitato ai fluidi per i quali sono previste prove con i simulanti A, C e D come definito dal DM n.338 del 22 luglio 1998, All. I, Cap. I) (Use limited to fluids for which tests are provided for simulants A, C and D as defined by Ministerial Decree no. 388 of 22 July 1998, Annex I, Chap. I.)</small></p> <hr/> <p>CONFORMEMENTE AL DOCUMENTO NORMATIVO ICIM / IN COMPLIANCE WITH ICIM NORMATIVE DOCUMENT</p> <p>0445CS</p> <hr/> <p>PRODOTTI E COMPONENTI A CONTATTO CON ALIMENTI SECONDO DISPOSIZIONI MOCA PRODUCTS AND COMPONENTS IN CONTACT WITH FOOD ACCORDING TO FCM REGULATIONS</p> <hr/>		
<p> ICIM S.p.A.</p> <hr/>		
<p>PRIMA EMISSIONE <i>FIRST ISSUE</i></p> <p>13/02/2020</p>	<p>EMISSIONE CORRENTE <i>CURRENT ISSUE</i></p> <p>13/02/2020</p>	<p>DATA DI SCADENZA <i>EXPIRING DATE</i></p> <p>12/02/2025</p>
<p><small>ICIM S.p.A. - Piazza Don Enrico Mapelli, 75 - 20099 Sesto San Giovanni (MI)</small></p>		

0549CIM_00_IT



CERTIFICAZIONE ICIM: CONTATTO CON ACQUA POTABILE

			
PRO N° 004 B Membro degli Accordi di Mutuo Riconoscimento EA, IAF e ILAC Signatory of EA, IAF and ILAC Mutual Recognition Agreements			
Certificazione di Prodotto <i>Product Certification</i>			
Certificato N. <i>Certificate No.</i>		ICIM-CAP-009810-00	
<small>ALL'AZIENDA / TO THE FIRM</small>			
TIERRE GROUP S.P.A. Via dell'Industria, 18 – 20032 Cormano (MI) Italia			
<small>UNITÀ OPERATIVE / OPERATIVE UNITS</small>			
Via dell'Industria, 18 – 20032 Cormano (MI) Italia			
<small>PER I SEGUENTI PRODOTTI / FOR THE FOLLOWING PRODUCTS</small>			
Raccordi ad innesto rapido in acciaio inox AISI 316L. <i>AISI 316L stainless steel push-in fittings.</i>			
<small>CON DENOMINAZIONE COMMERCIALE / WITH TRADE NAME/S</small>			
Serie XVR INOX AISI 316L / XVR SERIES INOX AISI 316L			
<small>CONFORMEMENTE AL DOCUMENTO NORMATIVO ICIM / IN COMPLIANCE WITH ICIM NORMATIVE DOCUMENT</small>			
0415CS Prodotti e componenti utilizzati a contatto con acqua destinata al consumo umano (acqua potabile) <i>0415CS Products and components in contact with water intendend for human consumption (drinking water)</i>			
 ICIM S.p.A.			
<small>PRIMA EMISSIONE FIRST ISSUE</small> 13/02/2020	<small>EMISSIONE CORRENTE CURRENT ISSUE</small> 13/02/2020	<small>DATA DI SCADENZA EXPIRING DATE</small> 12/02/2025	
<small>ICIM S.p.A. - Piazza Don Enrico Mapelli, 75 - 20099 Sesto San Giovanni (MI)</small>			

DS49CM_00_IT





Tierre Group S.p.a.

via dell'Industria, 18 - 20032 Cormano (MI)

Tel. +39 02 663088.1 - Fax +39 02 66304172

www.tierregroup.com - info@tierregroup.com

C.F. e P.IVA 12437570158

Cap. Soc. Euro 120.000,00 i.v. - REA MI-1558390

Serie XVR Inox AISI 316L - Ed. 1.2 - 08/20

LubeTeam Hydraulic S.r.l.

Administration and Headquarter:

Via Tufara Scautieri, 6

83018 - San Martino Valle Caudina (AV)

Office and Warehouse:

S.S. 7 Appia, Km. 237,00

82011 - Airola BN

ITALY

Tel. +39 0823 950 994

Fax +39 0823 412 546

www.lubeteam.it info@lubeteam.it

Italian VAT / C.F. e P.IVA: 01251720627

Follow us



This document is the property of LubeTeam Hydraulic S.r.l. All data reported here are for the exclusive use of the Receiver. Reproduction is not authorized without writing permission, in all or in part of the content of this document, in accordance to Law 633 art. 171, dated April 22, 1941.

Il presente documento è di proprietà della LubeTeam Hydraulic S.r.l. I dati riportati sono per esclusivo del destinatario. La riproduzione, di tutto o in parte, non è autorizzata senza permesso scritto secondo l'art. 171 della L. 633 del 22 Aprile 1941.