

CBF  
Valvole overcenter  
Cartucce



 HYDRAULIC  
COMPONENTS  
& FLUID CONTAMINATION  
CONTROL



All trademarks belong to their respective owners; third party trademarks, product names, trade names, corporate names and company names mentioned may be trademarks of their respective owners or registered trademarks of other companies and are used for instructional purposes and for the benefit of the owner, without any end of Copyright infringement in force.

Tutti i marchi riportati appartengono ai legittimi proprietari; marchi di terzi, nomi di prodotti, nomi commerciali, nomi corporativi e società citati possono essere di proprietà dei rispettivi titolari o registrati da altre società e sono stati utilizzati a puro scopo esplicativo e a beneficio del possessore, senza alcun fine di violazione dei diritti di Copyright vigenti.

Valvola OVERCENTER a cartuccia  
 Pilot assisted COUNTERBALANCE valve – cartridge type  
 mod. OVC60-C

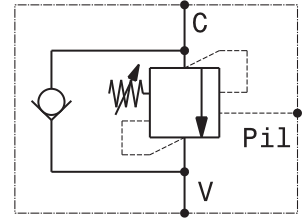
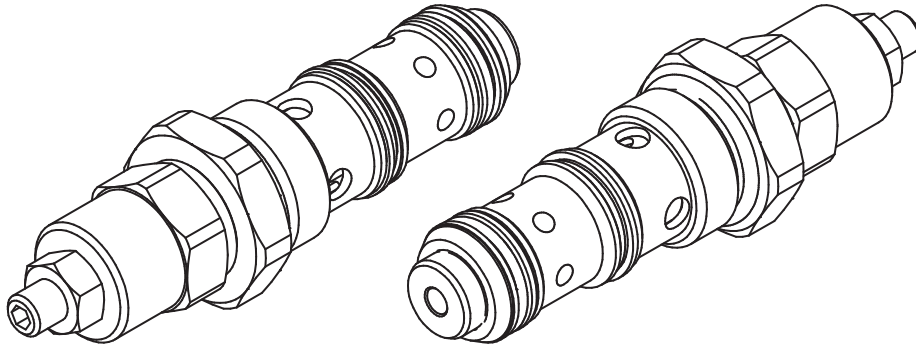

Portata massima Max flow	60 l/min 16 gpm
Pressione massima Max pressure	350 bar 5000 psi
Rapporto di pilotaggio standard Standard pilot ratio	4,25:1
Rapporto di pilotaggio a richiesta Pilot ratio upon request	3:1 8:1 10:1
Coppia di serraggio Installation torque	110 ÷ 120 Nm 82 ÷ 90 lb ft
Dati e tarature ottenuti usando olio con viscosità 30 cSt a 50°C Performances and calibrations are carried out by using hydraulic oil with 30 cSt viscosity at 50°C	
Viscosità consigliate Recommended viscosity	10 ÷ 420 cSt
Temperature di lavoro Working temperature	-20 ÷ +90 °C
Filtrazione assoluta Absolute filtration	25 µ

<b>Taratura Setting</b>	La valvola deve essere tarata almeno 1.3 volte la massima pressione indotta dal carico The valve must be set at least 1.3 times maximum load induced pressure		
Codice Code	Taratura standard Standard setting (Q=5 l/min)	Campo di taratura Adj. Pressure range	Colore molla Spring color
01	100 bar 1450 psi	20÷200 bar 290÷2900 psi	Bianco White
02	280 bar 4000 psi	50÷350 bar 725÷5000 psi	Nero Black

**Regolazioni - Adjustments**

 Vite esterna esagono incassato Leakproof hex socket screw	 Piombatura Sealing cap	 Cappello Cap
--	-------------------------------	---------------------

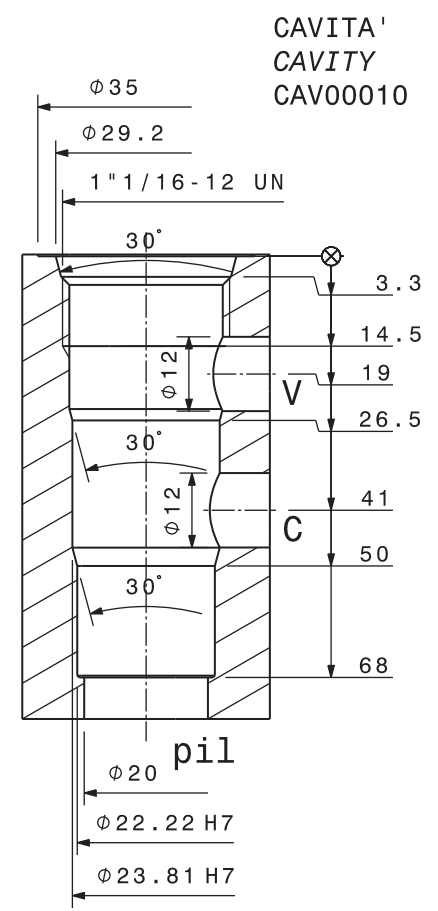
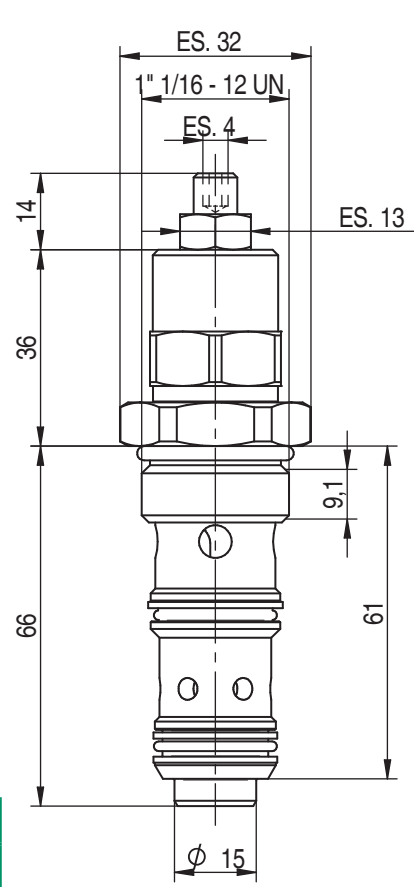

**Sigla di ordinazione / Ordering code**

OVC60-C - 02 -

Modello Type	Codice taratura Setting code 01, 02	Codice regolazione Adjustment code -, C, D
--------------	-------------------------------------	--

For flow diagram see PRESSURE DROP OVERCENTER VALVES (3)

I dati non sono impegnativi, CBF si riserva di apportare modifiche senza preavviso.  
 The specifications are not binding, CBF reserves the right to introduce modifications without notice.

Valvola OVERCENTER a cartuccia compensata in pressione  
 Pressure compensated, pilot assisted COUNTERBALANCE valve – cartridge type  
 mod. OVC60CC-C

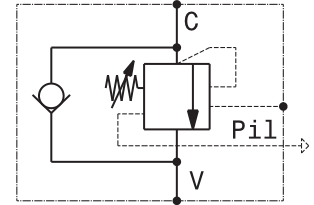
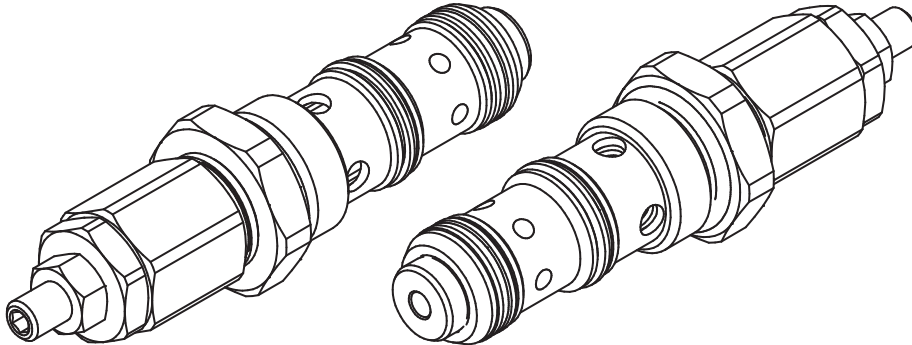

Portata massima Max flow	60 l/min 16 gpm
Pressione massima Max pressure	350 bar 5000 psi
Rapporto di pilotaggio standard Standard pilot ratio	4,25:1
Rapporto di pilotaggio a richiesta Pilot ratio upon request	3:1 8:1 10:1
Coppia di serraggio Installation torque	110 ÷ 120 Nm 82 ÷ 90 lb ft
Dati e tarature ottenuti usando olio con viscosità 30 cSt a 50°C Performances and calibrations are carried out by using hydraulic oil with 30 cSt viscosity at 50°C	
Viscosità consigliate Recommended viscosity	10 ÷ 420 cSt
Temperature di lavoro Working temperature	-20 ÷ +90 °C
Filtrazione assoluta Absolute filtration	25 µ

<b>Taratura Setting</b>	La valvola deve essere tarata almeno 1.3 volte la massima pressione indotta dal carico The valve must be set at least 1.3 times maximum load induced pressure		
Codice Code	Taratura standard Standard setting (Q=5 l/min)	Campo di taratura Adj. Pressure range	Colore molla Spring color
01	100 bar 1450 psi	20÷200 bar 290÷2900 psi	Bianco White
02	280 bar 4000 psi	50÷350 bar 725÷5000 psi	Nero Black

**Regolazioni - Adjustments**

Vite esterna esagono incassato Leakproof hex socket screw	Piombatura Sealing cap	Cappellotto Cap
--	---------------------------	--------------------

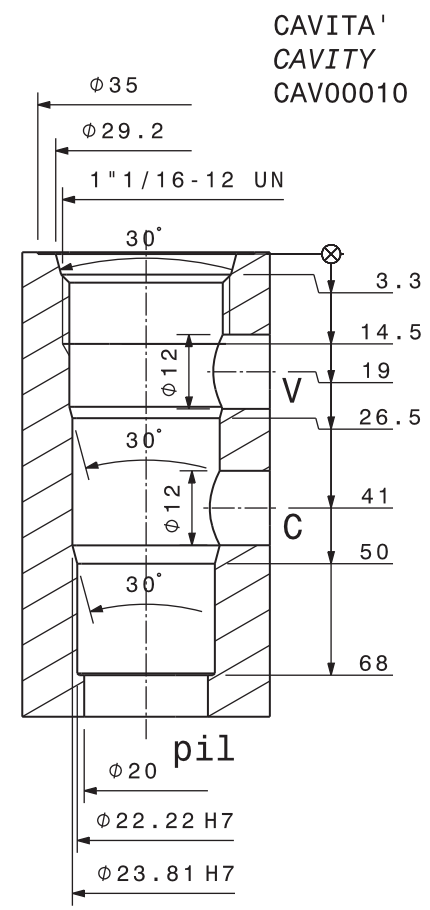
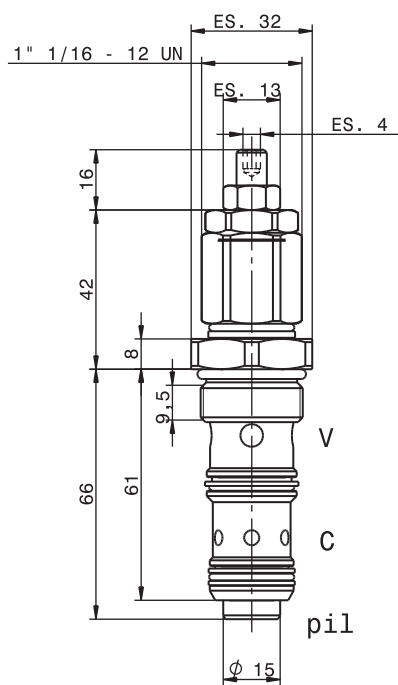

**Sigla di ordinazione / Ordering code**

OVC60CC-C — 02 — -

Modello Type	Codice taratura Setting code 01, 02	Codice regolazione Adjustment code -, C, D
-----------------	---	--

For flow diagram see PRESSURE DROP OVERCENTER VALVES (3)

I dati non sono impegnativi, CBF si riserva di apportare modifiche senza preavviso.  
 The specifications are not binding, CBF reserves the right to introduce modifications without notice.



Valvola OVERCENTER a cartuccia  
Pilot assisted COUNTERBALANCE valve – cartridge type  
mod. OVC150-C

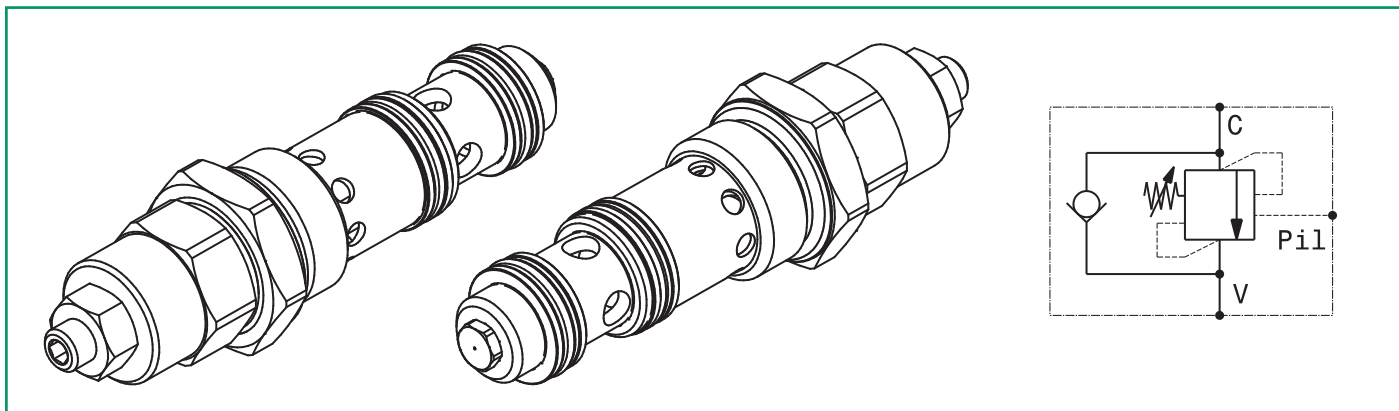

Portata massima Max flow	150 l/min 40 gpm
Pressione massima Max pressure	350 bar 5000 psi
Rapporto di pilotaggio standard Standard pilot ratio	4:1
Rapporto di pilotaggio a richiesta Pilot ratio upon request	3:1 8:1 10:1
Coppia di serraggio Installation torque	180 ÷ 210 Nm 135 ÷ 157 lb ft

<b>Taratura Setting</b>	La valvola deve essere tarata almeno 1.3 volte la massima pressione indotta dal carico The valve must be set at least 1.3 times maximum load induced pressure		
Codice Code	Taratura standard Standard setting (Q=5 l/min)	Campo di taratura Adj. Pressure range	Colore molla Spring color
01	100 bar 1450 psi	20÷200 bar 290÷2900 psi	Bianco White
02	280 bar 4000 psi	50÷350 bar 725÷5000 psi	Nero Black

**Regolazioni - Adjustments**

-	C	D
Vite esterna esagono incassato Leakproof hex socket screw	Piomatura Sealing cap	Cappello Cap

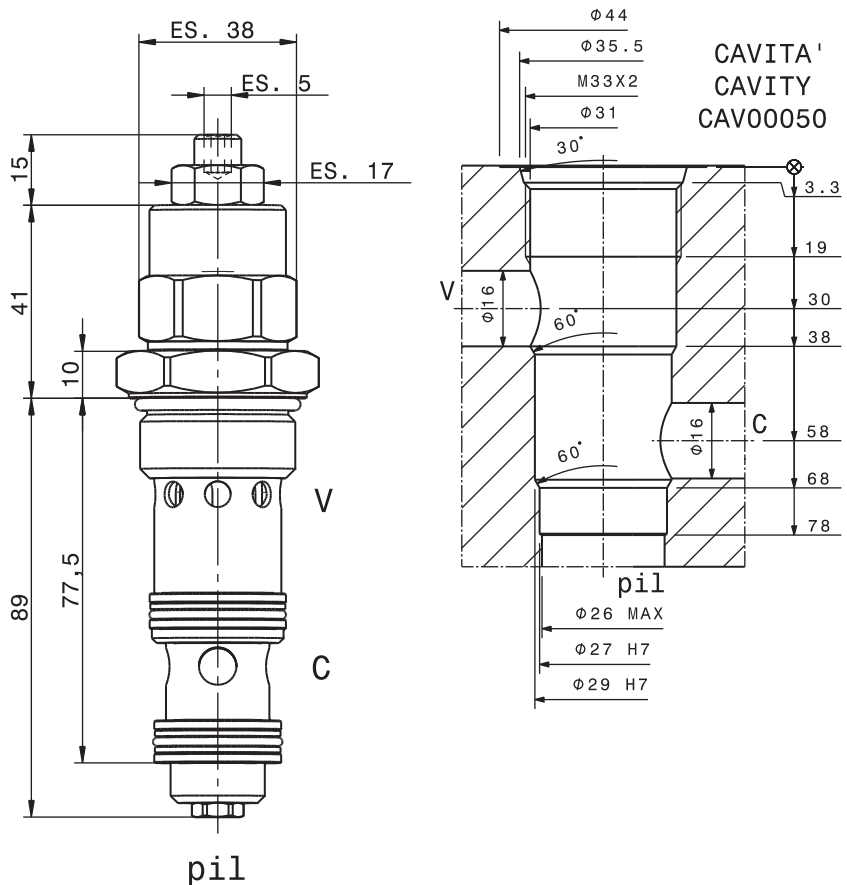

Sigla di ordinazione / Ordering code

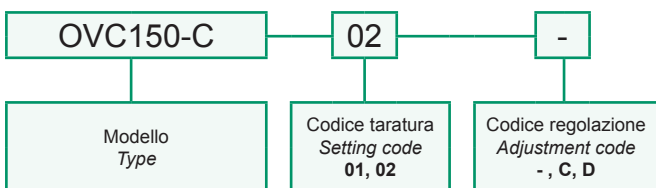

For flow diagram see  
PRESSURE DROP OVERCENTER VALVES (4)

Dati e tarature ottenuti usando olio con viscosità 30 cSt a 50°C Performances and calibrations are carried out by using hydraulic oil with 30 cSt viscosity at 50°C	
Viscosità consigliate Recommended viscosity	10 ÷ 420 cSt
Temperature di lavoro Working temperature	-20 ÷ +90 °C
Filtrazione assoluta Absolute filtration	25 µ

I dati non sono impegnativi, CBF si riserva di apportare modifiche senza preavviso.  
The specifications are not binding, CBF reserves the right to introduce modifications without notice.



Valvola OVERCENTER a cartuccia  
 Pilot assisted COUNTERBALANCE valve – cartridge type  
 mod. OVC200-C

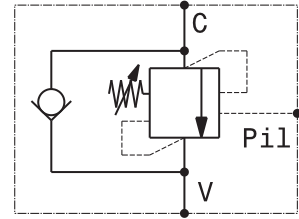
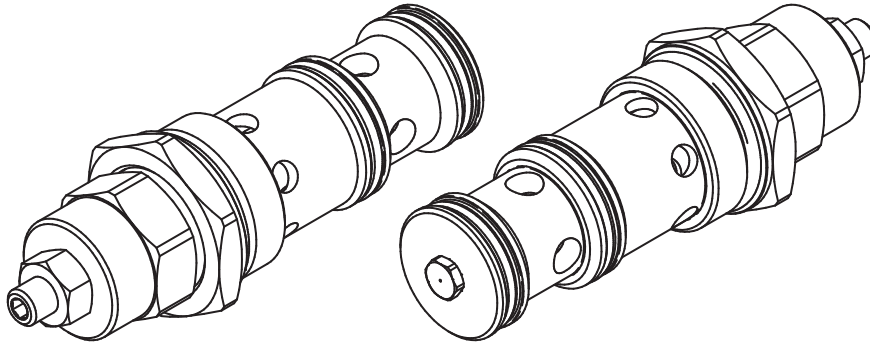

Portata massima Max flow	200 l/min 53 gpm
Pressione massima Max pressure	350 bar 5000 psi
Rapporto di pilotaggio standard Standard pilot ratio	4:1
Rapporto di pilotaggio a richiesta Pilot ratio upon request	3:1 8:1 10:1
Coppia di serraggio Installation torque	240 ÷ 260 Nm 180 ÷ 195 lb ft
Dati e tarature ottenuti usando olio con viscosità 30 cSt a 50°C Performances and calibrations are carried out by using hydraulic oil with 30 cSt viscosity at 50°C	
Viscosità consigliate Recommended viscosity	10 ÷ 420 cSt
Temperature di lavoro Working temperature	-20 ÷ +90 °C
Filtrazione assoluta Absolute filtration	25 µ

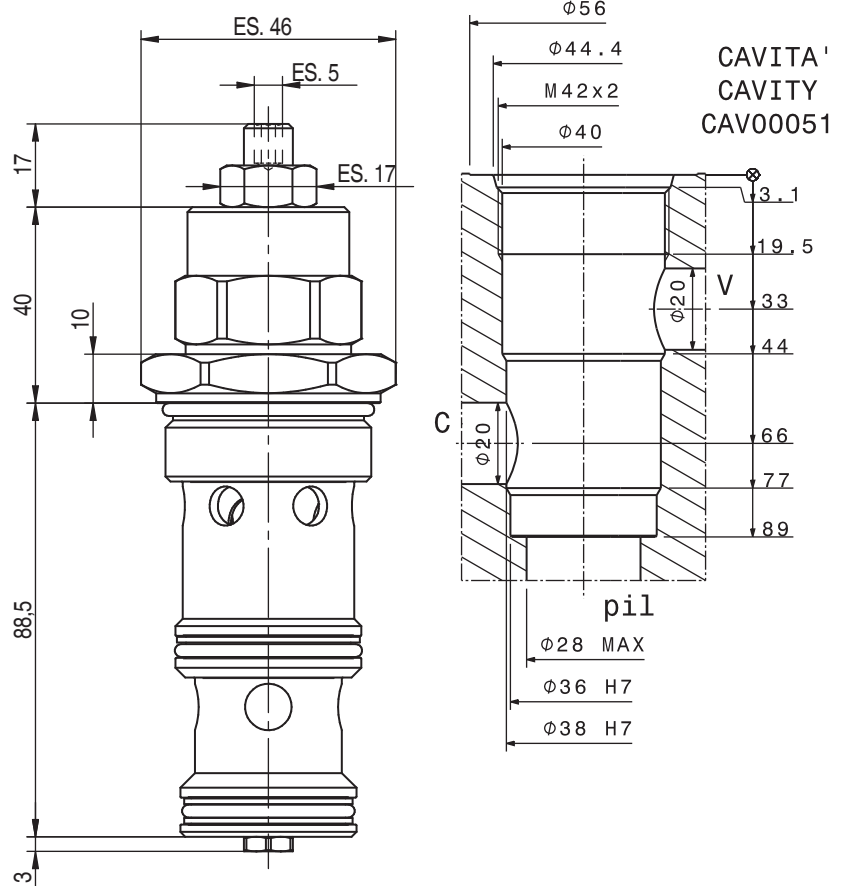

<b>Taratura Setting</b>	La valvola deve essere tarata almeno 1.3 volte la massima pressione indotta dal carico The valve must be set at least 1.3 times maximum load induced pressure		
Codice Code	Taratura standard Standard setting (Q=5 l/min)	Campo di taratura Adj. Pressure range	Colore molla Spring color
01	100 bar 1450 psi	20÷200 bar 290÷2900 psi	Bianco White
02	280 bar 4000 psi	50÷350 bar 725÷5000 psi	Nero Black

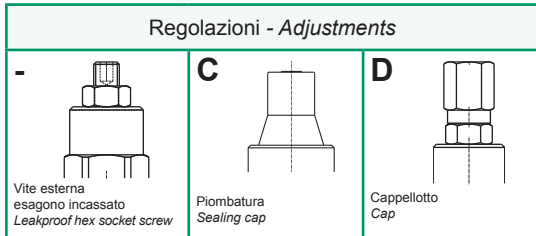

**Sigla di ordinazione / Ordering code**

OVC200-C — 02 — -

Modello Type	Codice taratura Setting code	Codice regolazione Adjustment code
OVC200-C	01, 02	-, C, D

For flow diagram see PRESSURE DROP OVERCENTER VALVES (5)

I dati non sono impegnativi, CBF si riserva di apportare modifiche senza preavviso.  
 The specifications are not binding, CBF reserves the right to introduce modifications without notice.

Valvola OVERCENTER a cartuccia compensata in pressione  
Pressure compensated, pilot assisted COUNTERBALANCE valve – cartridge type  
mod. OVC200CC-C

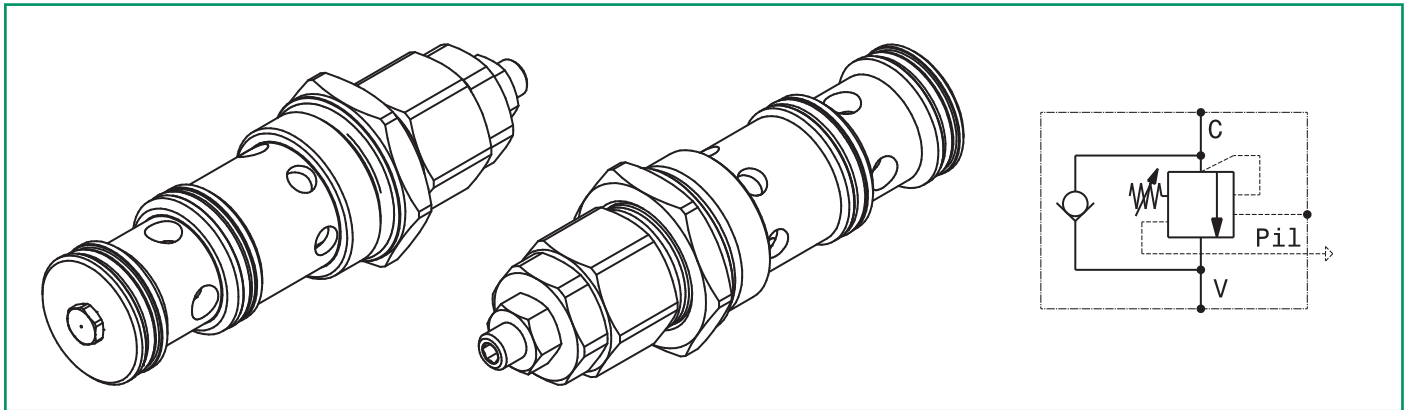

Portata massima Max flow	200 l/min 53 gpm
Pressione massima Max pressure	350 bar 5000 psi
Rapporto di pilotaggio standard Standard pilot ratio	4:1
Rapporto di pilotaggio a richiesta Pilot ratio upon request	3:1 8:1 10:1
Coppia di serraggio Installation torque	240 ÷ 260 Nm 180 ÷ 195 lb ft

<b>Taratura Setting</b>	La valvola deve essere tarata almeno 1.3 volte la massima pressione indotta dal carico The valve must be set at least 1.3 times maximum load induced pressure		
Codice Code	Taratura standard Standard setting (Q=5 l/min)	Campo di taratura Adj. Pressure range	Colore molla Spring color
01	100 bar 1450 psi	20÷200 bar 290÷2900 psi	Bianco White
02	280 bar 4000 psi	50÷350 bar 725÷5000 psi	Nero Black

**Regolazioni  
Adjustments**

 Vite esterna esagono incassato Leakproof hex socket screw	 Piombatura Sealing cap	 Cappello Cap
--	-------------------------------	---------------------

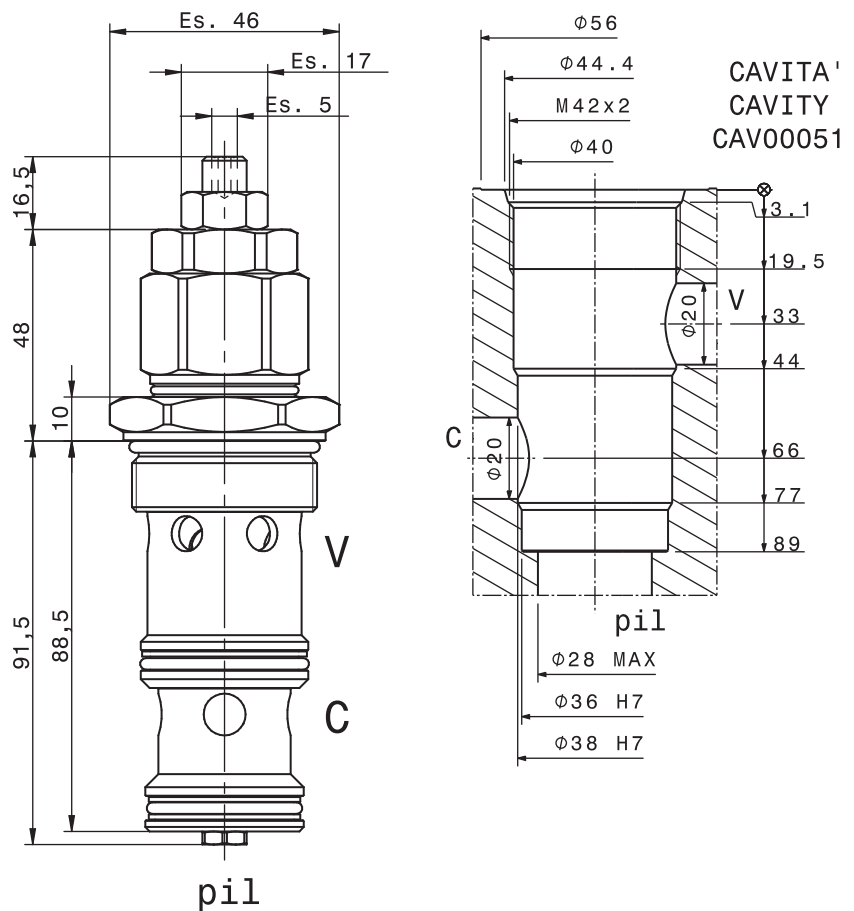

For flow diagram see  
PRESSURE DROP OVERCENTER VALVES (5)

**Sigla di ordinazione / Ordering code**

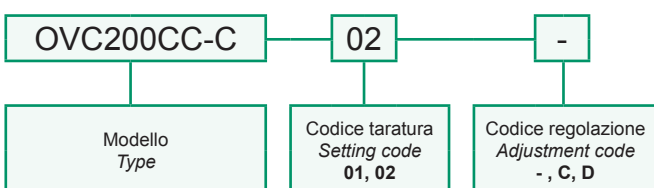

Dati e tarature ottenuti usando olio con viscosità 30 cSt a 50°C  
Performances and calibrations are carried out by using hydraulic oil with 30 cSt viscosity at 50°C

Viscosità consigliate Recommended viscosity	10 ÷ 420 cSt
Temperature di lavoro Working temperature	-20 ÷ +90 °C
Filtrazione assoluta Absolute filtration	25 µ

I dati non sono impegnativi, **CBF** si riserva di apportare modifiche senza preavviso.  
The specifications are not binding, **CBF** reserves the right to introduce modifications without notice.

Valvola OVERCENTER a cartuccia  
Pilot assisted COUNTERBALANCE valve – cartridge type  
mod. OVC6012-C

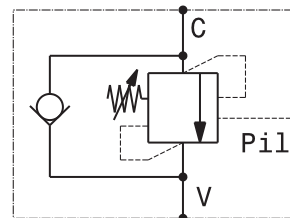
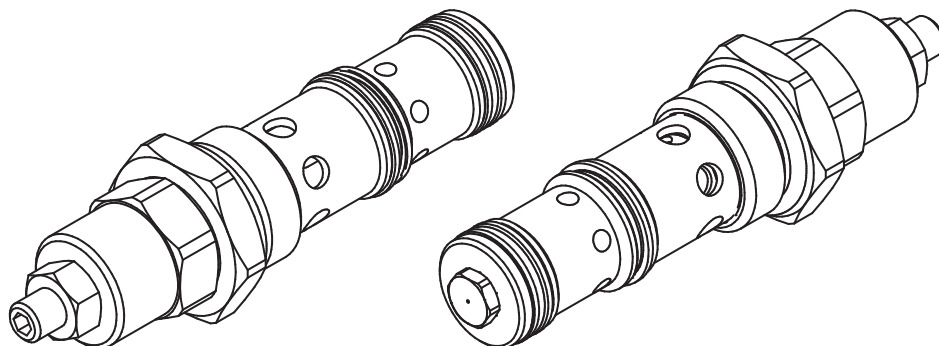

Portata massima Max flow	60 l/min 16 gpm
Pressione massima Max pressure	350 bar 5000 psi
Rapporto di pilotaggio standard Standard pilot ratio	4,25:1
Rapporto di pilotaggio a richiesta Pilot ratio upon request	3:1 8:1 10:1
Coppia di serraggio Installation torque	110 ÷ 120 Nm 82 ÷ 90 lb ft
Dati e tarature ottenuti usando olio con viscosità 30 cSt a 50°C Performances and calibrations are carried out by using hydraulic oil with 30 cSt viscosity at 50°C	
Viscosità consigliate Recommended viscosity	10 ÷ 420 cSt
Temperature di lavoro Working temperature	-20 ÷ +90 °C
Filtrazione assoluta Absolute filtration	25 µ

<b>Taratura Setting</b>	La valvola deve essere tarata almeno 1.3 volte la massima pressione indotta dal carico The valve must be set at least 1.3 times maximum load induced pressure		
Codice Code	Taratura standard Standard setting (Q=5 l/min)	Campo di taratura Adj. Pressure range	Colore molla Spring color
01	100 bar 1450 psi	20÷200 bar 290÷2900 psi	Bianco White
02	280 bar 4000 psi	50÷350 bar 725÷5000 psi	Nero Black

**Regolazioni - Adjustments**

-  Vite esterna esagono incassato Leakproof hex socket screw	C  Piombatura Sealing cap	D  Cappellotto Cap
---	------------------------------------	-----------------------------

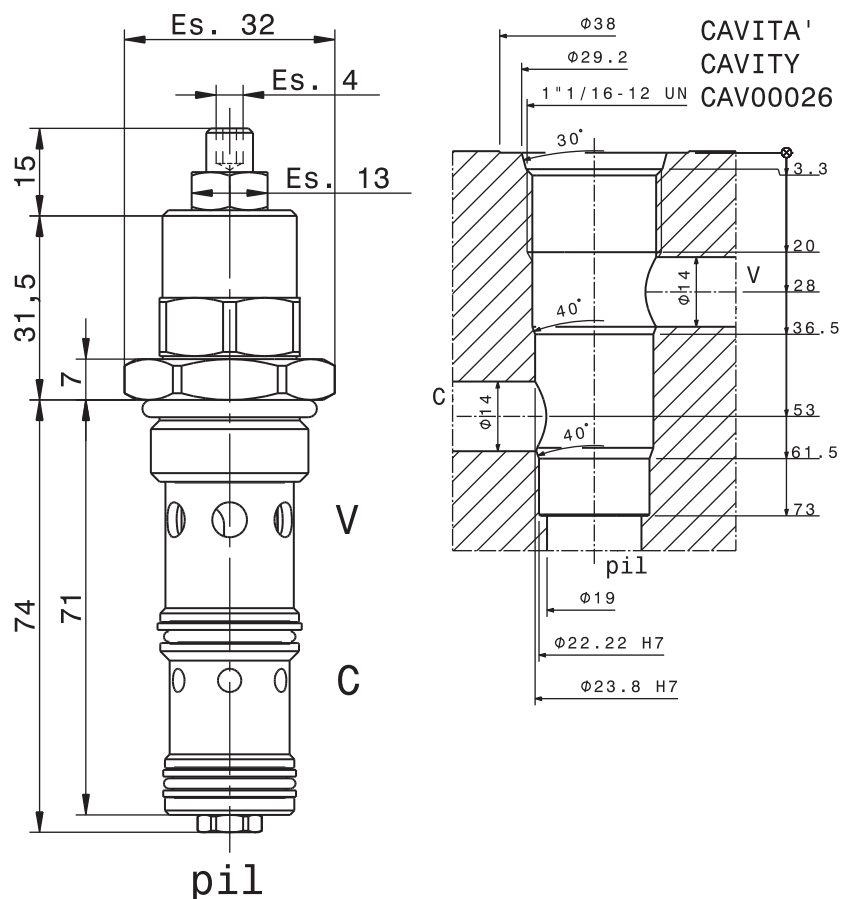

**Sigla di ordinazione / Ordering code**

OVC6012-C — 02 — -

Modello Type	Codice taratura Setting code 01, 02	Codice regolazione Adjustment code -, C, D
-----------------	---	--

For flow diagram see  
PRESSURE DROP OVERCENTER VALVES (3)

I dati non sono impegnativi, CBF si riserva di apportare modifiche senza preavviso.  
The specifications are not binding, CBF reserves the right to introduce modifications without notice.



Valvola OVERCENTER a cartuccia compensata in pressione  
 Pressure compensated, pilot assisted COUNTERBALANCE valve – cartridge type

mod. OVC6012CC-C

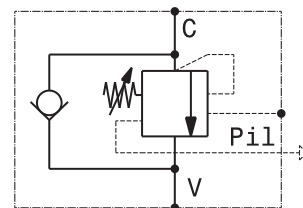
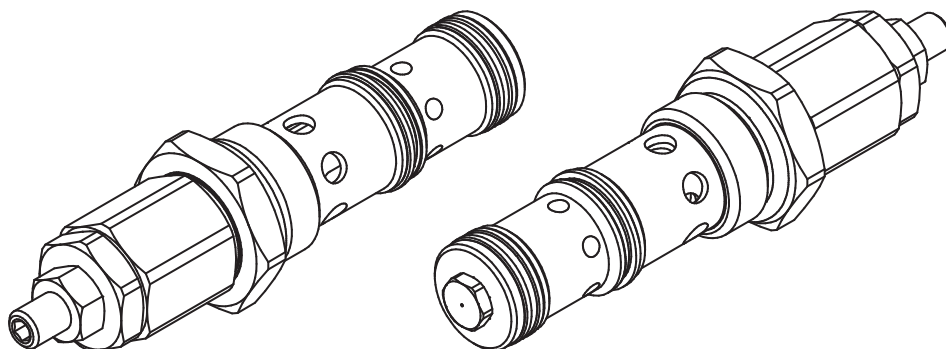

Portata massima Max flow	60 l/min 16 gpm
Pressione massima Max pressure	350 bar 5000 psi
Rapporto di pilotaggio standard Standard pilot ratio	4,25:1
Rapporto di pilotaggio a richiesta Pilot ratio upon request	3:1 8:1 10:1
Coppia di serraggio Installation torque	110 ÷ 120 Nm 82 ÷ 90 lb ft
Dati e tarature ottenuti usando olio con viscosità 30 cSt a 50°C Performances and calibrations are carried out by using hydraulic oil with 30 cSt viscosity at 50°C	
Viscosità consigliate Recommended viscosity	10 ÷ 420 cSt
Temperature di lavoro Working temperature	-20 ÷ +90 °C
Filtrazione assoluta Absolute filtration	25 µ

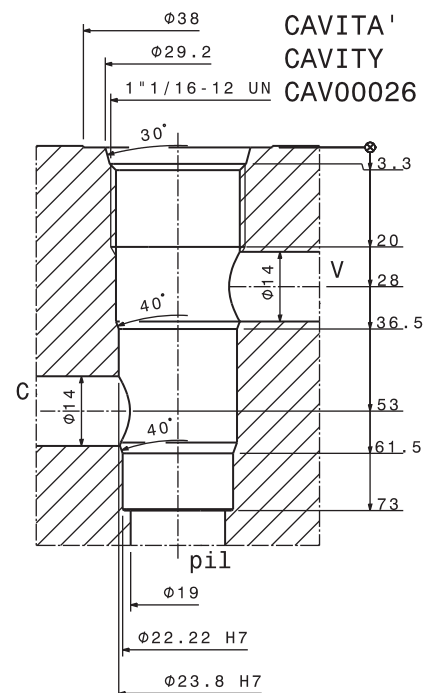
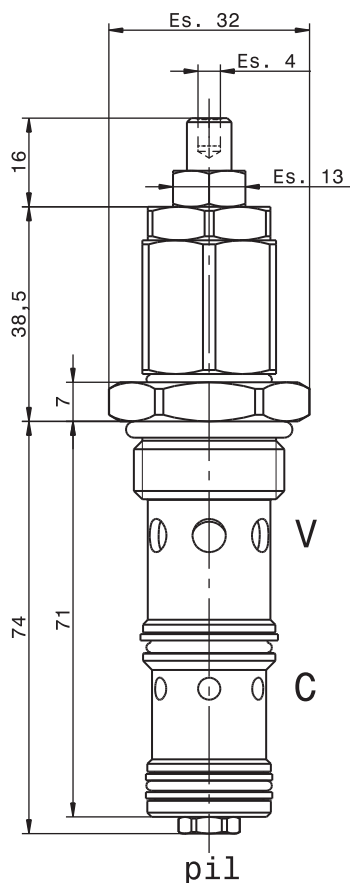

Taratura Setting	La valvola deve essere tarata almeno 1.3 volte la massima pressione indotta dal carico The valve must be set at least 1.3 times maximum load induced pressure		
Codice Code	Taratura standard Standard setting (Q=5 l/min)	Campo di taratura Adj. Pressure range	Colore molla Spring color
01	100 bar 1450 psi	20÷200 bar 290÷2900 psi	Bianco White
02	280 bar 4000 psi	50÷350 bar 725÷5000 psi	Nero Black

Regolazioni - Adjustments

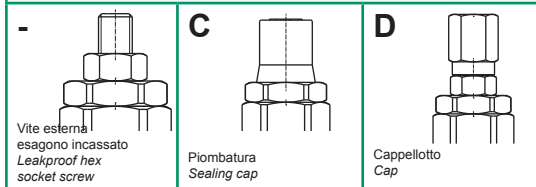

Sigla di ordinazione / Ordering code

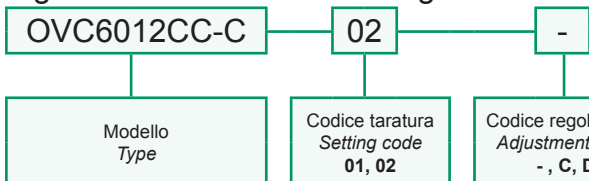

For flow diagram see PRESSURE DROP OVERCENTER VALVES (3)

I dati non sono impegnativi, CBF si riserva di apportare modifiche senza preavviso.  
 The specifications are not binding, CBF reserves the right to introduce modifications without notice.



Valvola OVERCENTER a cartuccia compensata in pressione  
Pressure compensated, pilot assisted COUNTERBALANCE valve – cartridge type  
mod. OVC15016CC-C

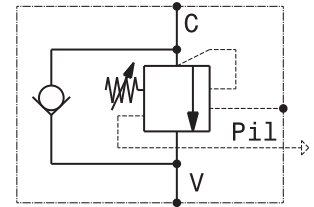
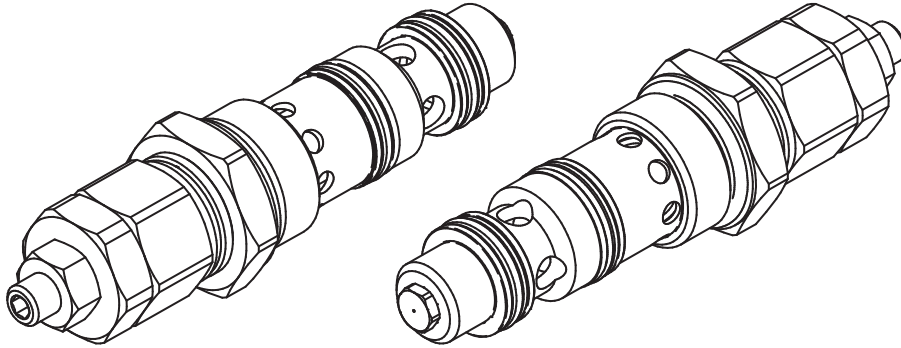

Portata massima Max flow	150 l/min 40 gpm
Pressione massima Max pressure	350 bar 5000 psi
Rapporto di pilotaggio standard Standard pilot ratio	4:1
Rapporto di pilotaggio a richiesta Pilot ratio upon request	3:1 8:1 10:1
Coppia di serraggio Installation torque	180 ÷ 210 Nm 135 ÷ 157 lb ft
Dati e tarature ottenuti usando olio con viscosità 30 cSt a 50°C Performances and calibrations are carried out by using hydraulic oil with 30 cSt viscosity at 50°C	
Viscosità consigliate Recommended viscosity	10 ÷ 420 cSt
Temperature di lavoro Working temperature	-20 ÷ +90 °C
Filtrazione assoluta Absolute filtration	25 µ

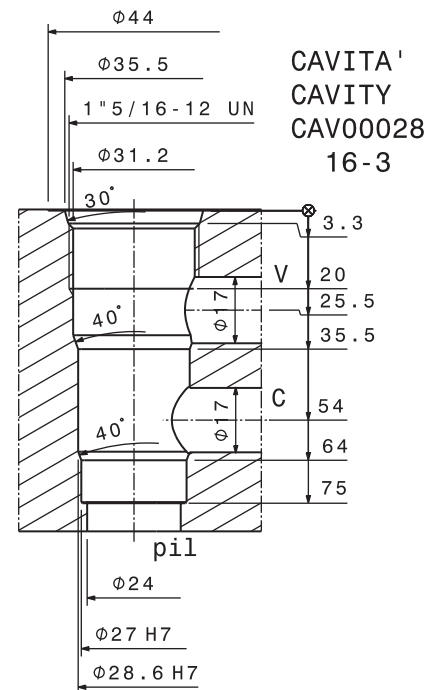
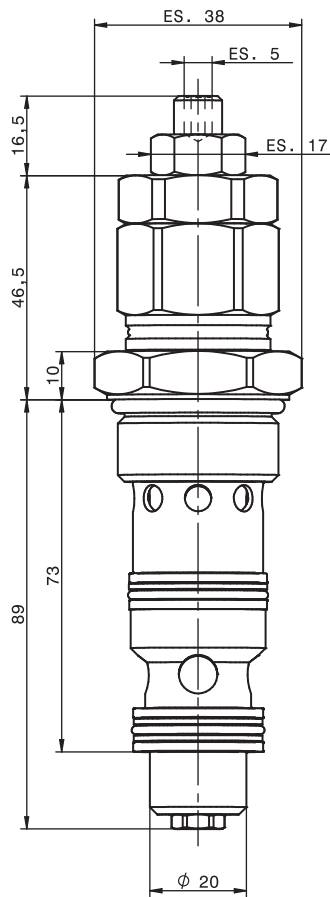

<b>Taratura Setting</b>	La valvola deve essere tarata almeno 1.3 volte la massima pressione indotta dal carico The valve must be set at least 1.3 times maximum load induced pressure		
Codice Code	Taratura standard Standard setting (Q=5 l/min)	Campo di taratura Adj. Pressure range	Colore molla Spring color
01	100 bar 1450 psi	20÷200 bar 290÷2900 psi	Bianco White
02	280 bar 4000 psi	50÷350 bar 725÷5000 psi	Nero Black

Regolazioni - Adjustments

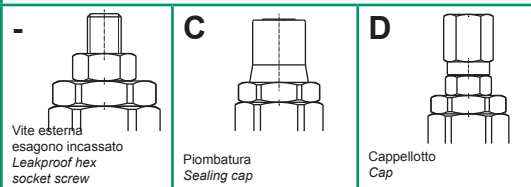

Sigla di ordinazione / Ordering code

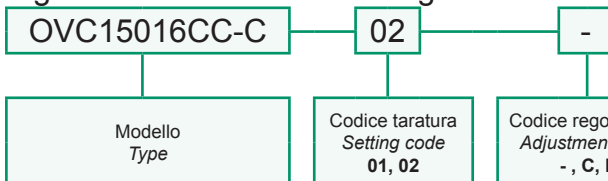

For flow diagram see PRESSURE DROP OVERCENTER VALVES (4)

I dati non sono impegnativi, CBF si riserva di apportare modifiche senza preavviso.  
The specifications are not binding, CBF reserves the right to introduce modifications without notice.

Valvola OVERCENTER a cartuccia compensata in pressione  
Pressure compensated, pilot assisted COUNTERBALANCE valve – cartridge type

mod. OVC20020CC-C

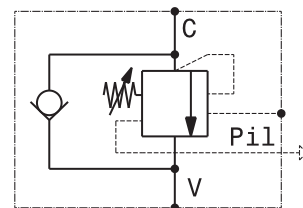
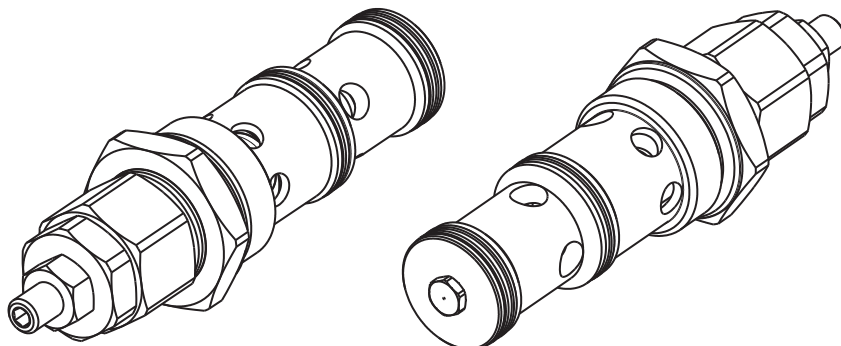

Portata massima Max flow	200 l/min 53 gpm
Pressione massima Max pressure	350 bar 5000 psi
Rapporto di pilotaggio standard Standard pilot ratio	4:1
Rapporto di pilotaggio a richiesta Pilot ratio upon request	3:1 8:1 10:1
Coppia di serraggio Installation torque	240 ÷ 260 Nm 180 ÷ 195 lb ft

Dati e tarature ottenuti usando olio con viscosità 30 cSt a 50°C  
Performances and calibrations are carried out by using hydraulic oil with 30 cSt viscosity at 50°C

Viscosità consigliate Recommended viscosity	10 ÷ 420 cSt
Temperature di lavoro Working temperature	-20 ÷ +90 °C
Filtrazione assoluta Absolute filtration	25 µ

<b>Taratura Setting</b>	La valvola deve essere tarata almeno 1.3 volte la massima pressione indotta dal carico The valve must be set at least 1.3 times maximum load induced pressure		
Codice Code	Taratura standard Standard setting (Q=5 l/min)	Campo di taratura Adj. Pressure range	Colore molla Spring color
01	100 bar 1450 psi	20÷200 bar 290÷2900 psi	Bianco White
02	280 bar 4000 psi	50÷350 bar 725÷5000 psi	Nero Black

Regolazioni - Adjustments

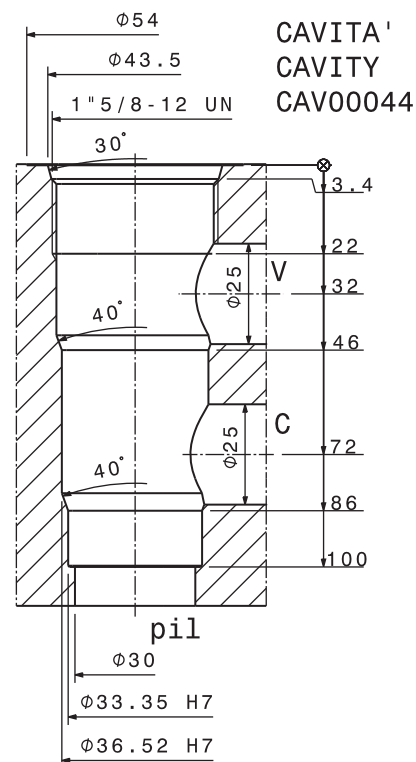
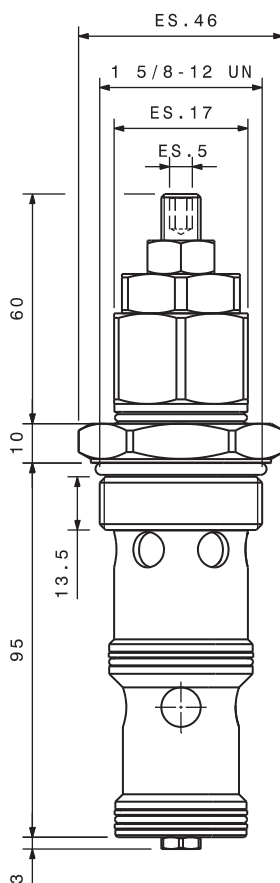
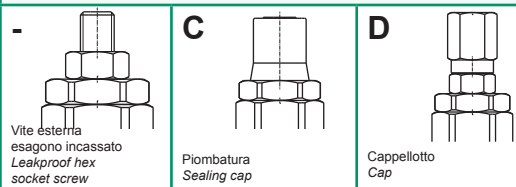

Sigla di ordinazione / Ordering code

OVC20020CC-C — 02 — -

Modello Type	Codice taratura Setting code 01, 02	Codice regolazione Adjustment code -, C, D
-----------------	---	--

For flow diagram see  
PRESSURE DROP OVERCENTER VALVES (5)

I dati non sono impegnativi, CBF si riserva di apportare modifiche senza preavviso.  
The specifications are not binding, CBF reserves the right to introduce modifications without notice.

Valvola OVERCENTER a cartuccia  
Pilot assisted COUNTERBALANCE valve – cartridge type  
mod. OVC20020-C

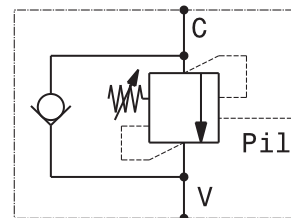
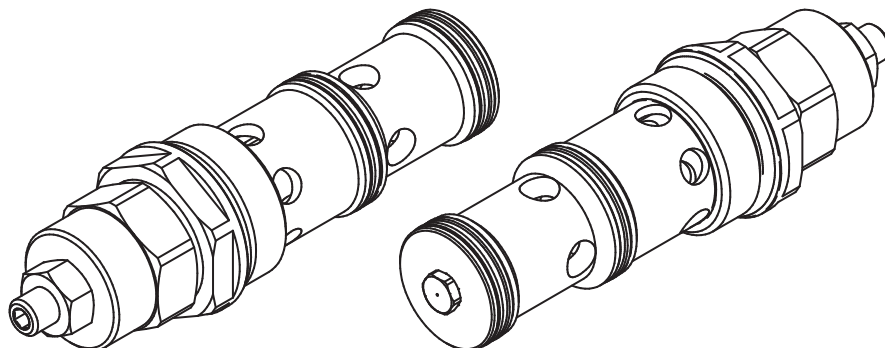

Portata massima Max flow	200 l/min 53 gpm
Pressione massima Max pressure	350 bar 5000 psi
Rapporto di pilotaggio standard Standard pilot ratio	4:1
Rapporto di pilotaggio a richiesta Pilot ratio upon request	3:1 8:1 10:1
Coppia di serraggio Installation torque	240 ÷ 260 Nm 180 ÷ 195 lb ft
Dati e tarature ottenuti usando olio con viscosità 30 cSt a 50°C Performances and calibrations are carried out by using hydraulic oil with 30 cSt viscosity at 50°C	
Viscosità consigliate Recommended viscosity	10 ÷ 420 cSt
Temperature di lavoro Working temperature	-20 ÷ +90 °C
Filtrazione assoluta Absolute filtration	25 µ

<b>Taratura Setting</b>	La valvola deve essere tarata almeno 1.3 volte la massima pressione indotta dal carico. The valve must be set at least 1.3 times maximum load induced pressure		
Codice Code	Taratura standard Standard setting (Q=5 l/min)	Campo di taratura Adj. Pressure range	Colore molla Spring color
01	100 bar 1450 psi	20÷200 bar 290÷2900 psi	Bianco White
02	280 bar 4000 psi	50÷350 bar 725÷5000 psi	Nero Black

**Regolazioni - Adjustments**

-	<b>C</b>	<b>D</b>
Vite esterna esagono incassato Leakproof hex socket screw	Piombatura Sealing cap	Cappello Cap

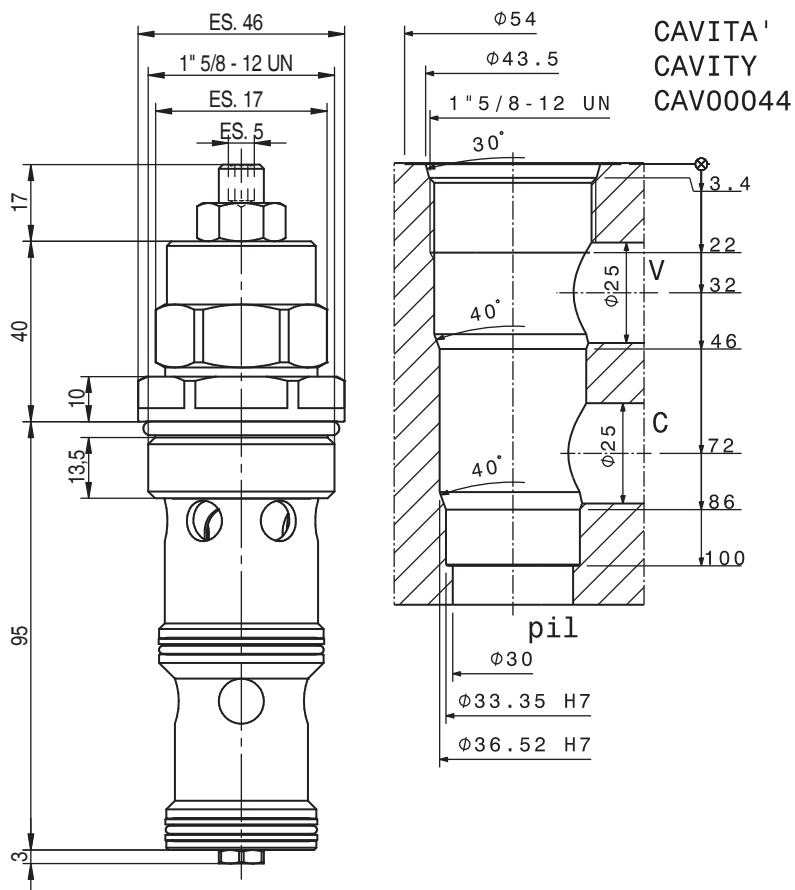

**Sigla di ordinazione / Ordering code**

OVC20020-C — 02 — -

Modello Type	Codice taratura Setting code 01, 02	Codice regolazione Adjustment code -, C, D
-----------------	---	--

For flow diagram see  
PRESSURE DROP OVERCENTER VALVES (5)

I dati non sono impegnativi, CBF si riserva di apportare modifiche senza preavviso.  
The specifications are not binding, CBF reserves the right to introduce modifications without notice.



Valvola OVERCENTER a cartuccia  
 Pilot assisted COUNTERBALANCE valve – cartridge type  
 mod. OVC2008-C

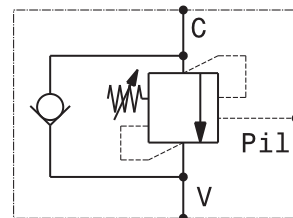
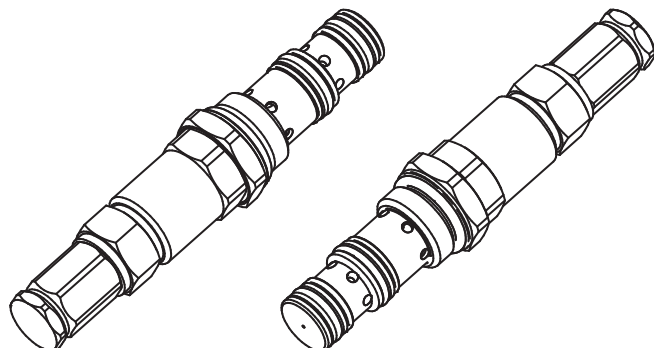

Portata massima Max flow	30 l/min 7.9 gpm
Pressione massima Max pressure	350 bar 5000 psi
Rapporto di pilotaggio standard Standard pilot ratio	4:1
Rapporto di pilotaggio a richiesta Pilot ratio upon request	3:1 8:1 10:1
Coppia di serraggio Installation torque	30 ÷ 35 Nm 22.5 ÷ 26 lb ft

Dati e tarature ottenuti usando olio con viscosità 30 cSt a 50°C Performances and calibrations are carried out by using hydraulic oil with 30 cSt viscosity at 50°C	
Viscosità consigliate Recommended viscosity	10 ÷ 420 cSt
Temperature di lavoro Working temperature	-20 ÷ +90 °C
Filtrazione assoluta Absolute filtration	25 µ

<b>Taratura Setting</b>	La valvola deve essere tarata almeno 1.3 volte la massima pressione indotta dal carico The valve must be set at least 1.3 times maximum load induced pressure		
Codice Code	Taratura standard Standard setting (Q=5 l/min)	Campo di taratura Adj. Pressure range	Colore molla Spring color
01	100 bar 1450 psi	20÷200 bar 290÷2900 psi	Bianco White
02	280 bar 4000 psi	50÷350 bar 725÷5000 psi	Nero Black

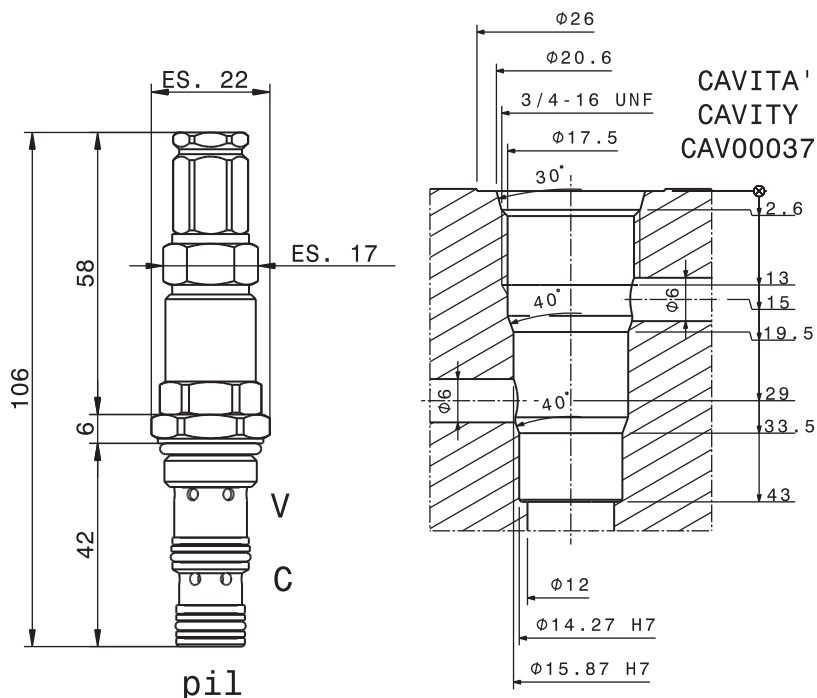

Sigla di ordinazione / Ordering code

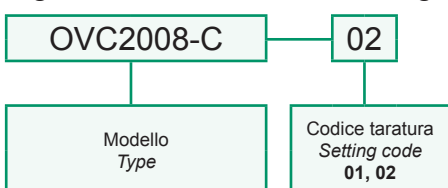

For flow diagram see  
 PRESSURE DROP OVERCENTER VALVES (1)

I dati non sono impegnativi, CBF si riserva di apportare modifiche senza preavviso.  
 The specifications are not binding, CBF reserves the right to introduce modifications without notice.

Valvola OVERCENTER a cartuccia compensata in pressione  
 Pressure compensated, pilot assisted COUNTERBALANCE valve – cartridge type

mod. OVC2008CC-C

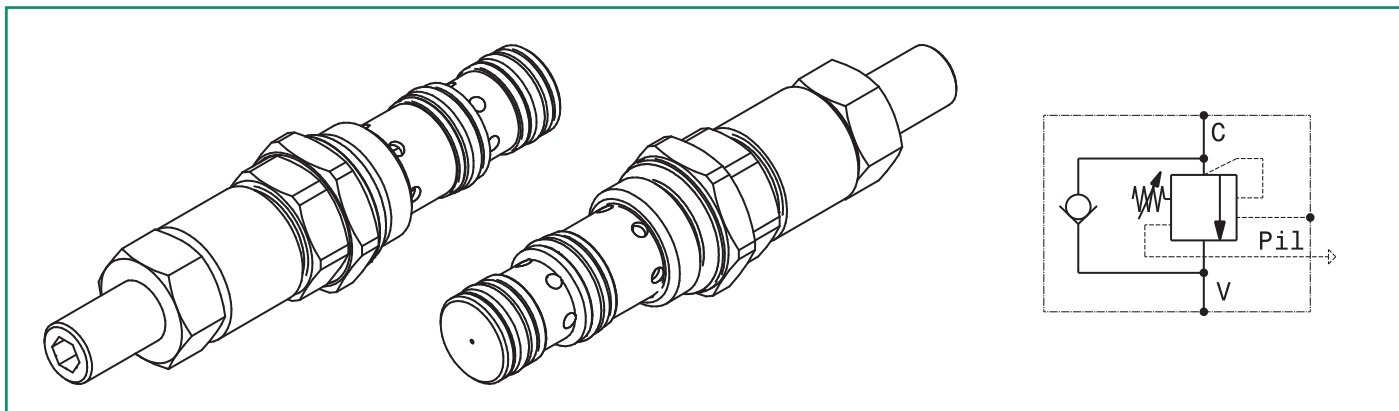

Portata massima Max flow	20 l/min 5.5 gpm
Pressione massima Max pressure	350 bar 5000 psi
Rapporto di pilotaggio standard Standard pilot ratio	4:1
Rapporto di pilotaggio a richiesta Pilot ratio upon request	3:1 8:1 10:1
Coppia di serraggio Installation torque	30 ÷ 35 Nm 22.5 ÷ 26 lb ft

Dati e tarature ottenuti usando olio con viscosità 30 cSt a 50°C  
 Performances and calibrations are carried out by using hydraulic oil with 30 cSt viscosity at 50°C

Viscosità consigliate Recommended viscosity	10 ÷ 420 cSt
Temperature di lavoro Working temperature	-20 ÷ +90 °C
Filtrazione assoluta Absolute filtration	25 µ

<b>Taratura Setting</b>	La valvola deve essere tarata almeno 1.3 volte la massima pressione indotta dal carico The valve must be set at least 1.3 times maximum load induced pressure		
Codice Code	Taratura standard Standard setting (Q=5 l/min)	Campo di taratura Adj. Pressure range	Colore molla Spring color
01	100 bar 1450 psi	20÷200 bar 290÷2900 psi	Bianco White
02	280 bar 4000 psi	50÷350 bar 725÷5000 psi	Nero Black

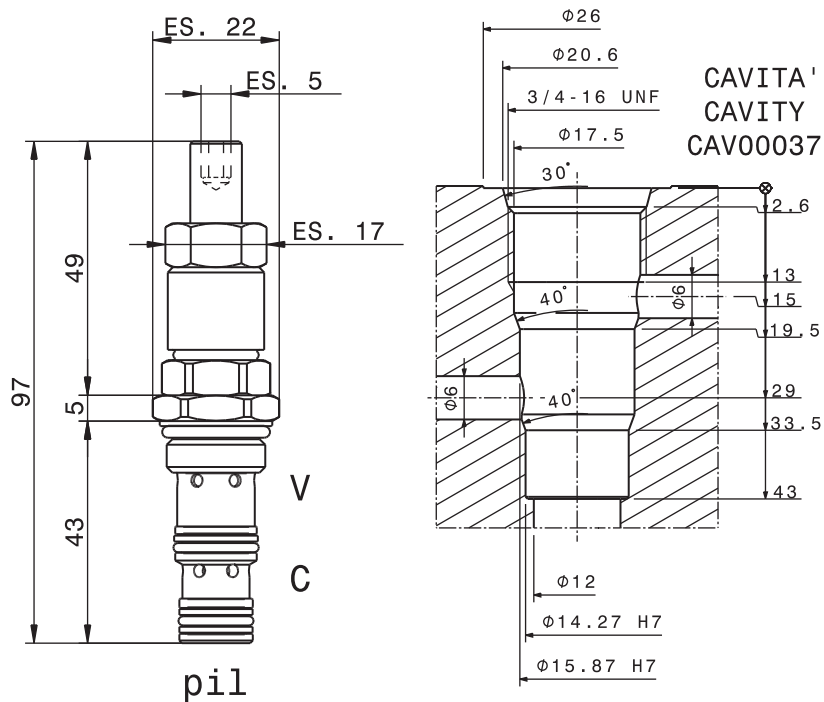

Sigla di ordinazione / Ordering code

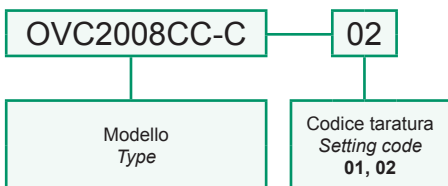

For flow diagram see  
 PRESSURE DROP OVERCENTER VALVES (1)

I dati non sono impegnativi, CBF si riserva di apportare modifiche senza preavviso.  
 The specifications are not binding, CBF reserves the right to introduce modifications without notice.

Valvola OVERCENTER a cartuccia  
 Pilot assisted COUNTERBALANCE valve – cartridge type  
 mod. OVC4010-C

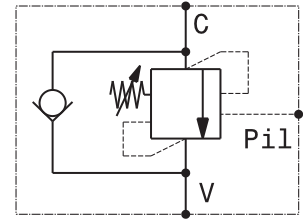
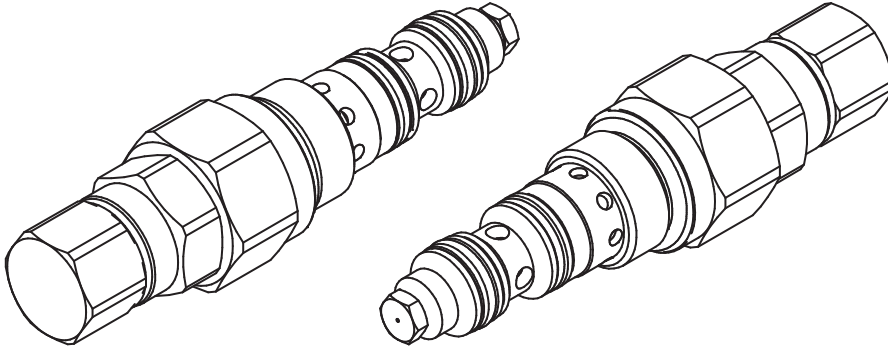

Portata massima Max flow	50 l/min 13.2 gpm
Pressione massima Max pressure	350 bar 5000 psi
Rapporto di pilotaggio standard Standard pilot ratio	4:1
Rapporto di pilotaggio a richiesta Pilot ratio upon request	3:1 8:1 10:1
Coppia di serraggio Installation torque	50 ÷ 60 Nm 38 ÷ 45 lb ft

Dati e tarature ottenuti usando olio con viscosità 30 cSt a 50°C Performances and calibrations are carried out by using hydraulic oil with 30 cSt viscosity at 50°C	
Viscosità consigliate Recommended viscosity	10 ÷ 420 cSt
Temperature di lavoro Working temperature	-20 ÷ +90 °C
Filtrazione assoluta Absolute filtration	25 µ

<b>Taratura Setting</b>	La valvola deve essere tarata almeno 1.3 volte la massima pressione indotta dal carico. The valve must be set at least 1.3 times maximum load induced pressure		
Codice Code	Taratura standard Standard setting (Q=5 l/min)	Campo di taratura Adj. Pressure range	Colore molla Spring color
01	100 bar 1450 psi	20÷200 bar 290÷2900 psi	Bianco White
02	280 bar 4000 psi	50÷350 bar 725÷5000 psi	Nero Black

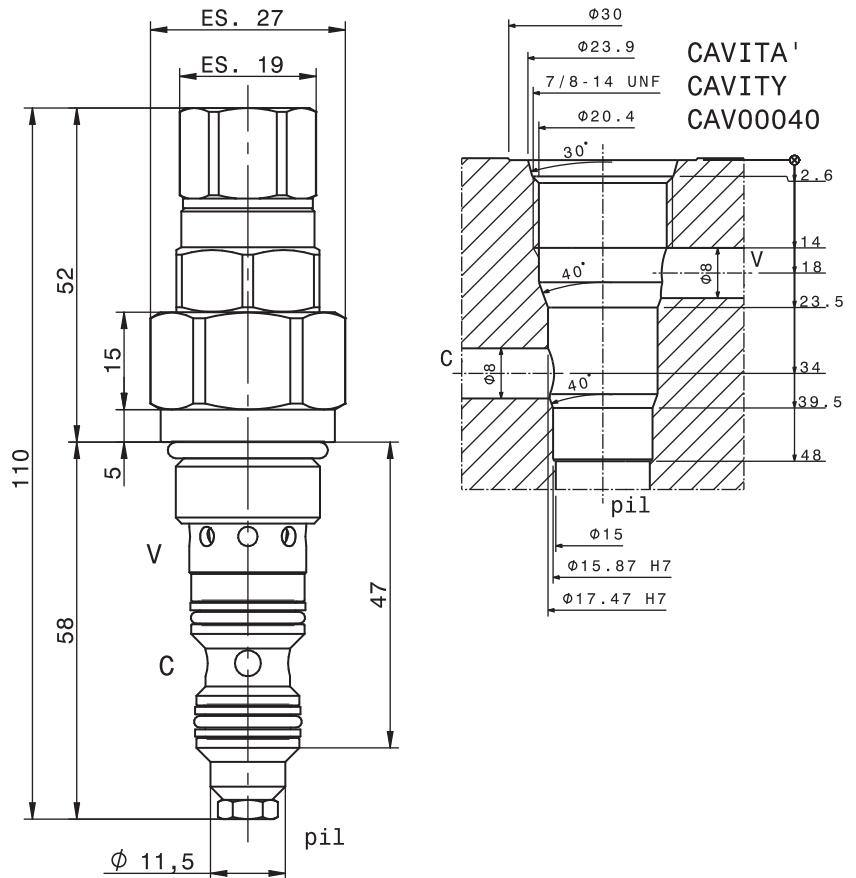

Sigla di ordinazione / Ordering code

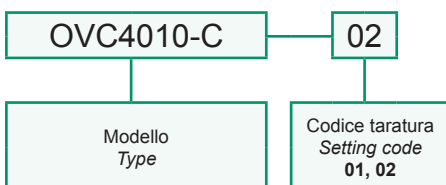

For flow diagram see  
 PRESSURE DROP OVERCENTER VALVES (2)

I dati non sono impegnativi, CBF si riserva di apportare modifiche senza preavviso.  
 The specifications are not binding, CBF reserves the right to introduce modifications without notice.

Valvola OVERCENTER a cartuccia compensata in pressione  
 Pressure compensated, pilot assisted COUNTERBALANCE valve – cartridge type  
 mod. OVC4010CC-C

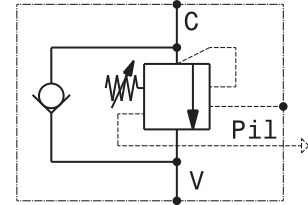
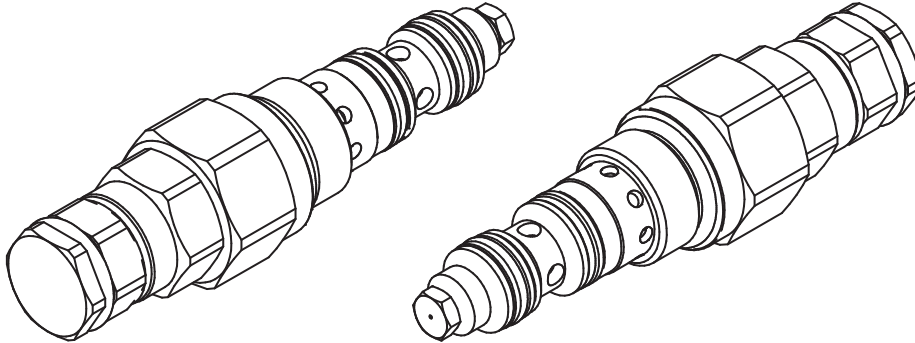

Portata massima Max flow	40 l/min 10.5 gpm
Pressione massima Max pressure	350 bar 5000 psi
Rapporto di pilotaggio standard Standard pilot ratio	4:1
Rapporto di pilotaggio a richiesta Pilot ratio upon request	3:1 8:1 10:1
Coppia di serraggio Installation torque	50 ÷ 60 Nm 38 ÷ 45 lb ft

Dati e tarature ottenuti usando olio con viscosità 30 cSt a 50°C Performances and calibrations are carried out by using hydraulic oil with 30 cSt viscosity at 50°C	
Viscosità consigliate Recommended viscosity	10 ÷ 420 cSt
Temperature di lavoro Working temperature	-20 ÷ +90 °C
Filtrazione assoluta Absolute filtration	25 µ

Taratura Setting	La valvola deve essere tarata almeno 1.3 volte la massima pressione indotta dal carico The valve must be set at least 1.3 times maximum load induced pressure		
Codice Code	Taratura standard Standard setting (Q=5 l/min)	Campo di taratura Adj. Pressure range	Colore molla Spring color
01	100 bar 1450 psi	20÷200 bar 290÷2900 psi	Bianco White
02	280 bar 4000 psi	50÷350 bar 725÷5000 psi	Nero Black

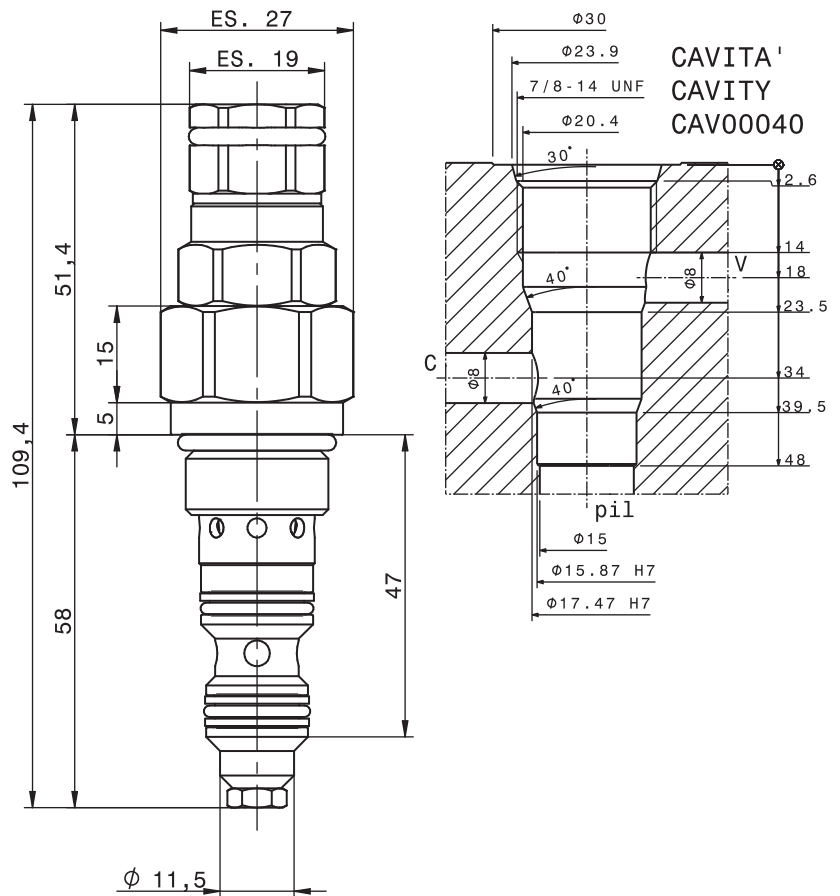

Sigla di ordinazione / Ordering code

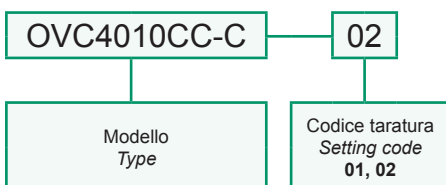

For flow diagram see  
 PRESSURE DROP OVERCENTER VALVES (2)

I dati non sono impegnativi, CBF si riserva di apportare modifiche senza preavviso.  
 The specifications are not binding, CBF reserves the right to introduce modifications without notice.

Valvola OVERCENTER a cartuccia  
 Pilot assisted COUNTERBALANCE valve – cartridge type  
 mod. OVC3008-C-3P

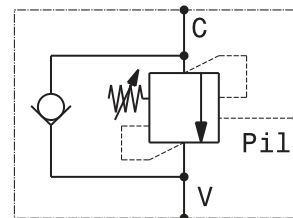
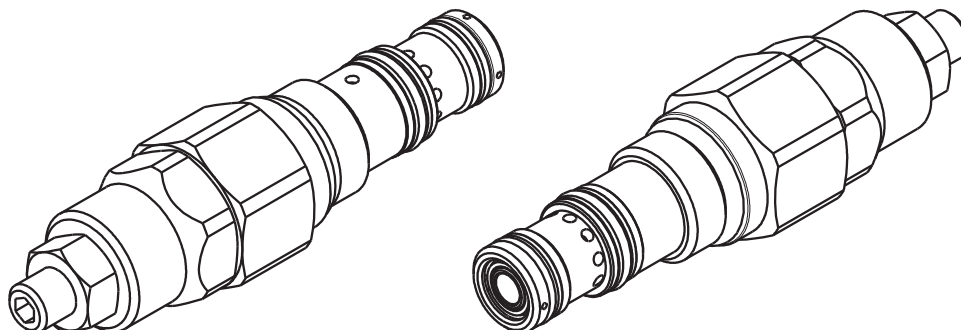

Portata massima Max flow	30 l/min 7.9 gpm
Pressione massima Max pressure	350 bar 5000 psi
Rapporto di pilotaggio standard Standard pilot ratio	4:1
Rapporto di pilotaggio a richiesta Pilot ratio upon request	3:1
Coppia di serraggio Installation torque	30 ÷ 35 Nm 22.5 ÷ 26 lb ft

Dati e tarature ottenuti usando olio con viscosità 30 cSt a 50°C Performances and calibrations are carried out by using hydraulic oil with 30 cSt viscosity at 50°C	
Viscosità consigliate Recommended viscosity	10 ÷ 420 cSt
Temperature di lavoro Working temperature	-20 ÷ +90 °C
Filtrazione assoluta Absolute filtration	25 µ

<b>Taratura Setting</b>	La valvola deve essere tarata almeno 1.3 volte la massima pressione indotta dal carico The valve must be set at least 1.3 times maximum load induced pressure	
Codice Code	Taratura standard Standard setting (Q=5 l/min)	Campo di taratura Adj. Pressure range
01	100 bar 1450 psi	20÷200 bar 290÷2900 psi
02	280 bar 4000 psi	50÷350 bar 725÷5000 psi

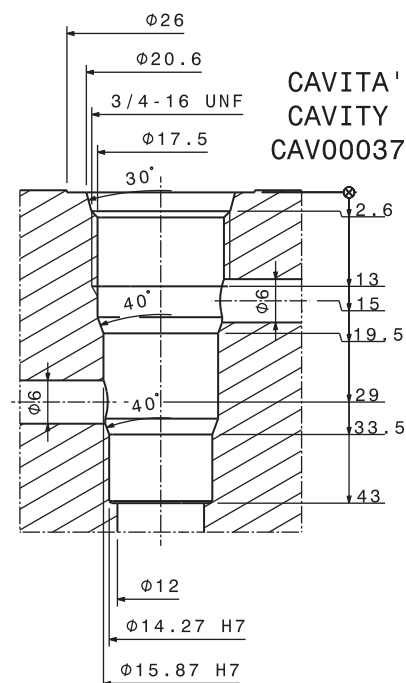
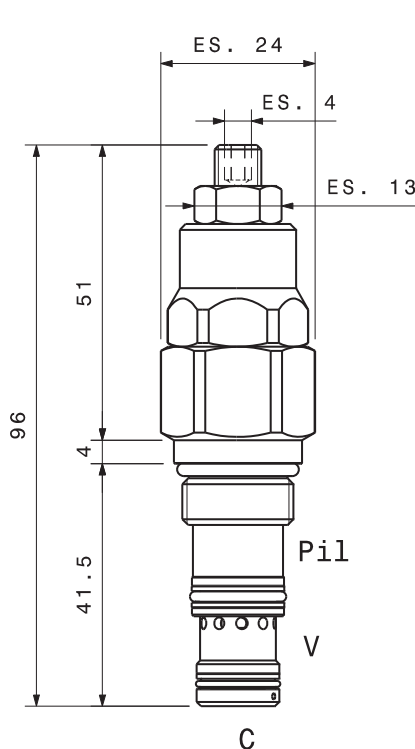

Sigla di ordinazione / Ordering code

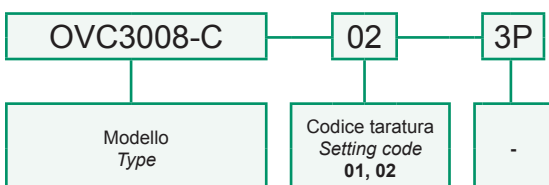

I dati non sono impegnativi, CBF si riserva di apportare modifiche senza preavviso.  
 The specifications are not binding, CBF reserves the right to introduce modifications without notice.





## LubeTeam Hydraulic S.r.l.

*Administration and Headquarter:*

Via Tufara Scautieri, 6

83018 - San Martino Valle Caudina (AV)

*Office and Warehouse:*

S.S. 7 Appia, Km. 237,00

82011 - Airola BN

ITALY

Tel. +39 0823 950 994

Fax +39 0823 412 546

[www.lubeteam.it](http://www.lubeteam.it) [info@lubeteam.it](mailto:info@lubeteam.it)

Italian VAT / C.F. e P.IVA: 01251720627

Follow us



This document is the property of LubeTeam Hydraulic S.r.l. All data reported here are for the exclusive use of the Receiver. Reproduction is not authorized without writing permission, in all or in part of the content of this document, in accordance to Law 633 art. 171, dated April 22, 1941.

Il presente documento è di proprietà della LubeTeam Hydraulic S.r.l. I dati riportati sono per esclusivo del destinatario. La riproduzione, di tutto o in parte, non è autorizzata senza permesso scritto secondo l'art. 171 della L. 633 del 22 Aprile 1941.