

CBF
Valvole per motori
Parker



 HYDRAULIC
COMPONENTS
& FLUID CONTAMINATION
CONTROL



All trademarks belong to their respective owners; third party trademarks, product names, trade names, corporate names and company names mentioned may be trademarks of their respective owners or registered trademarks of other companies and are used for instructional purposes and for the benefit of the owner, without any end of Copyright infringement in force.

Tutti i marchi riportati appartengono ai legittimi proprietari; marchi di terzi, nomi di prodotti, nomi commerciali, nomi corporativi e società citati possono essere di proprietà dei rispettivi titolari o registrati da altre società e sono stati utilizzati a puro scopo esplicativo e a beneficio del possessore, senza alcun fine di violazione dei diritti di Copyright vigenti.

Valvola OVERCENTER doppio effetto con sblocco freno flangiabile su motori PARKER, serie TE-TJ
Double effect OVERCENTER valve with brake unclamping, flangeable to PARKER motors, TE-TJ series

mod. OVC-DE-FMP-SF-VC-12

Corpo in alluminio
Aluminium body

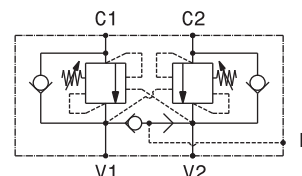
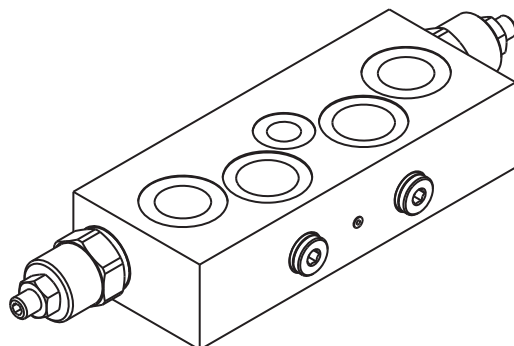

Portata massima Max flow	60 l/min 16 gpm
Pressione massima Max pressure	350 bar 5000 psi
Rapporto di pilotaggio standard Standard pilot ratio	4,25:1
Rapporto di pilotaggio a richiesta Pilot ratio upon request	3:1 8:1 10:1

Taratura Setting	La valvola deve essere tarata almeno 1.3 volte la massima pressione indotta dal carico The valve must be set at least 1.3 times maximum load induced pressure			
	Codice Code	Taratura standard Standard setting (Q=5 l/min)	Campo di taratura Adj. Pressure range	Colore molla Spring color
	01	100 bar 1450 psi	20+200 bar 290+2900 psi	Bianco White
	02	280 bar 4000 psi	50+350 bar 725+5000 psi	Nero Black

Regolazioni Adjustments		
-	C	D
Vite esterna esagono incassato Leakproof hex socket screw	Piombatura Sealing cap	Cappello Cap

Dati e tarature ottenuti usando olio con viscosità 30 cSt a 50°C Performances and calibrations are carried out by using hydraulic oil with 30 cSt viscosity at 50°C	
Viscosità consigliate Recommended viscosity	10 ÷ 420 cSt
Temperature di lavoro Working temperature	-20 ÷ +90 °C
Filtrazione assoluta Absolute filtration	25 µ

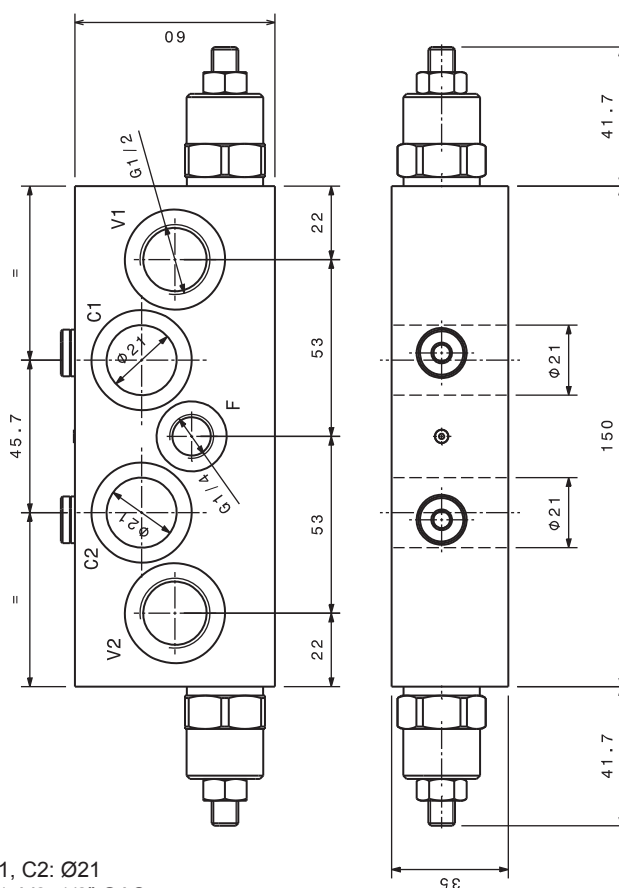

C1, C2: Ø21
V1, V2: 1/2" GAS
F: 1/4" GAS

Sigla di ordinazione / Ordering code

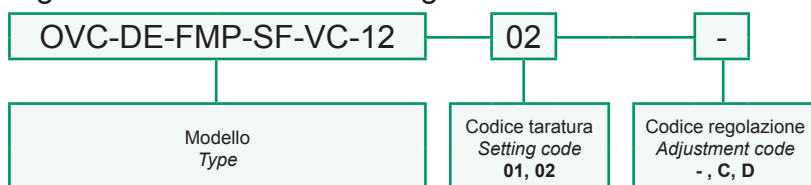

Vite cava disponibile a richiesta Nipple screw available upon request	Codice di ordinazione Ordering Code KITV0003
--	---

I dati non sono impegnativi, CBF si riserva di apportare modifiche senza preavviso.
The specifications are not binding, CBF reserves the right to introduce modifications without notice.

LubeTeam Hydraulic S.r.l.

Administration and Headquarter:

Via Tufara Scautieri, 6

83018 - San Martino Valle Caudina (AV)

Office and Warehouse:

S.S. 7 Appia, Km. 237,00

82011 - Airola BN

ITALY

Tel. +39 0823 950 994

Fax +39 0823 412 546

www.lubeteam.it info@lubeteam.it

Italian VAT / C.F. e P.IVA: 01251720627

Follow us



This document is the property of LubeTeam Hydraulic S.r.l. All data reported here are for the exclusive use of the Receiver. Reproduction is not authorized without writing permission, in all or in part of the content of this document, in accordance to Law 633 art. 171, dated April 22, 1941.

Il presente documento è di proprietà della LubeTeam Hydraulic S.r.l. I dati riportati sono per esclusivo del destinatario. La riproduzione, di tutto o in parte, non è autorizzata senza permesso scritto secondo l'art. 171 della L. 633 del 22 Aprile 1941.