

CBF

Valvole per motori
Samhydraulik



 HYDRAULIC
COMPONENTS
& FLUID CONTAMINATION
CONTROL



All trademarks belong to their respective owners; third party trademarks, product names, trade names, corporate names and company names mentioned may be trademarks of their respective owners or registered trademarks of other companies and are used for instructional purposes and for the benefit of the owner, without any end of Copyright infringement in force.

Tutti i marchi riportati appartengono ai legittimi proprietari; marchi di terzi, nomi di prodotti, nomi commerciali, nomi corporativi e società citati possono essere di proprietà dei rispettivi titolari o registrati da altre società e sono stati utilizzati a puro scopo esplicativo e a beneficio del possessore, senza alcun fine di violazione dei diritti di Copyright vigenti.

Valvola OVERCENTER doppio effetto con sblocco freno flangiabile su motori SAMHYDRAULIK AG-AR
 Double effect OVERCENTER valve with brake unclamping, flangeable to SAMHYDRAULIK motors AG-AR

mod. OVC-DE-FMSH-SF-VC-12

Corpo in alluminio

Aluminium body

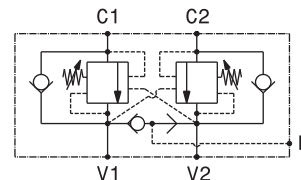
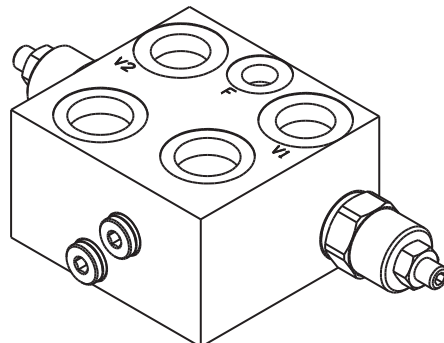

Portata massima Max flow	60 l/min 16 gpm
Pressione massima Max pressure	350 bar 5000 psi
Rapporto di pilotaggio standard Standard pilot ratio	4,25:1
Rapporto di pilotaggio a richiesta Pilot ratio upon request	3:1 8:1 10:1

Taratura Setting
 La valvola deve essere tarata almeno 1.3 volte la massima pressione indotta dal carico
 The valve must be set at least 1.3 times maximum load induced pressure

Codice Code	Taratura standard Standard setting (Q=5 l/min)	Campo di taratura Adj. Pressure range	Colore molla Spring color
01	100 bar 1450 psi	20+200 bar 290+2900 psi	Bianco White
02	280 bar 4000 psi	50+350 bar 725+5000 psi	Nero Black

Regolazioni Adjustments

 Vite esterna esagono incassato Leakproof hex socket screw	 Piombatura Sealing cap	 Cappellotto Cap
--	-------------------------------	------------------------

Dati e tarature ottenuti usando olio con viscosità 30 cSt a 50°C
 Performances and calibrations are carried out by using hydraulic oil with 30 cSt viscosity at 50°C

Viscosità consigliate Recommended viscosity	10 ÷ 420 cSt
Temperature di lavoro Working temperature	-20 ÷ +90 °C
Filtrazione assoluta Absolute filtration	25 µ

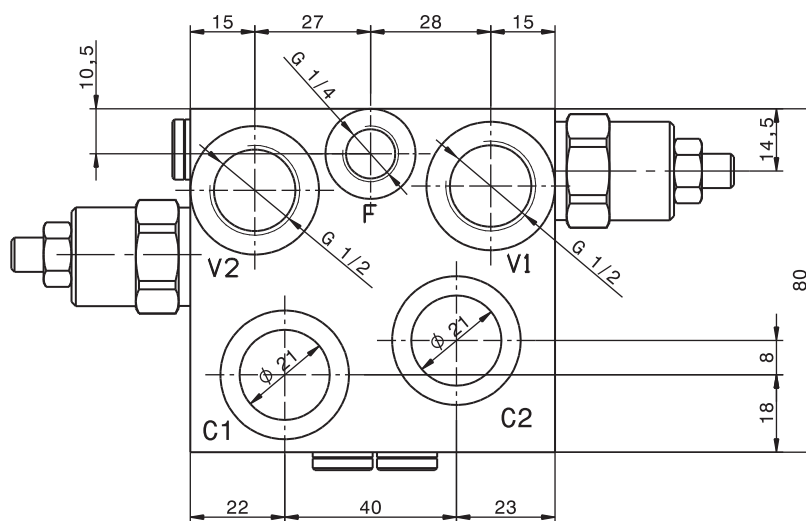
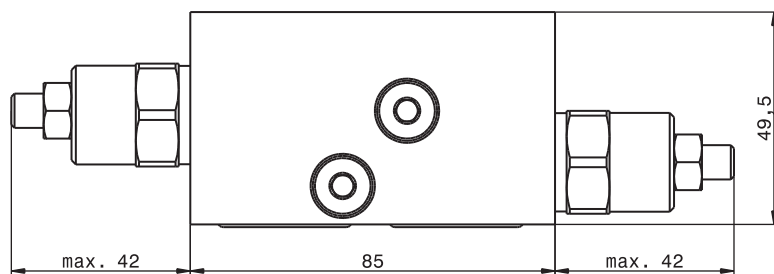

Vite cava disponibile a richiesta Nipple screw available upon request	Codice di ordinazione Ordering Code KITV0005
--	---

Sigla di ordinazione / Ordering code

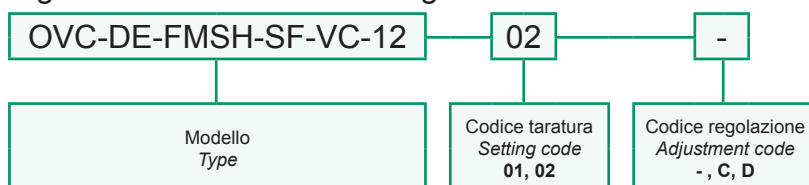

I dati non sono impegnativi, CBF si riserva di apportare modifiche senza preavviso.
 The specifications are not binding, CBF reserves the right to introduce modifications without notice.

Valvola OVERCENTER semplice effetto con sblocco freno flangiabile su motori SAMHYDRAULIK AG-AR
 Single effect OVERCENTER valve with brake unclamping, flangeable to SAMHYDRAULIK motors AG-AR
 mod. OVC-SE-FMSH-SF-VC-12

Corpo in alluminio
 Aluminium body

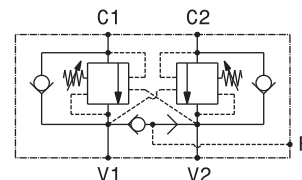
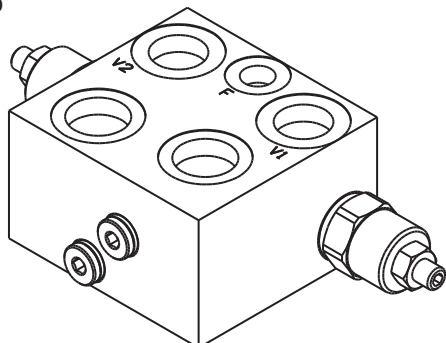

Portata massima Max flow	60 l/min 16 gpm
Pressione massima Max pressure	350 bar 5000 psi
Rapporto di pilotaggio standard Standard pilot ratio	4,25:1
Rapporto di pilotaggio a richiesta Pilot ratio upon request	3:1 8:1 10:1

Taratura Setting
 La valvola deve essere tarata almeno 1.3 volte la massima pressione indotta dal carico
 The valve must be set at least 1.3 times maximum load induced pressure

Codice Code	Taratura standard Standard setting (Q=5 l/min)	Campo di taratura Adj. Pressure range	Colore molla Spring color
01	100 bar 1450 psi	20+200 bar 290+2900 psi	Bianco White
02	280 bar 4000 psi	50+350 bar 725+5000 psi	Nero Black

Regolazioni Adjustments

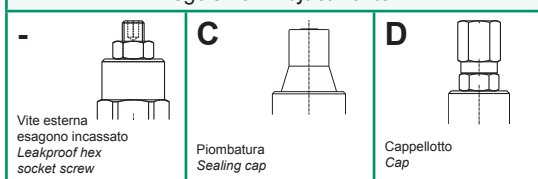

Dati e tarature ottenuti usando olio con viscosità 30 cSt a 50°C
 Performances and calibrations are carried out by using hydraulic oil with 30 cSt viscosity at 50°C

Viscosità consigliate Recommended viscosity	10 ÷ 420 cSt
Temperature di lavoro Working temperature	-20 ÷ +90 °C
Filtrazione assoluta Absolute filtration	25 µ

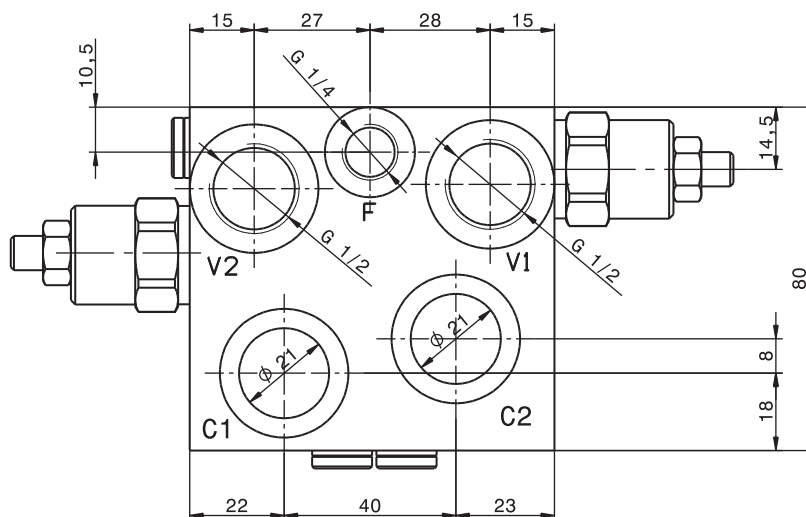
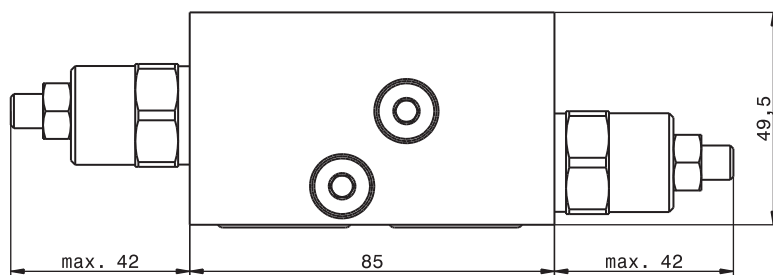

Vite cava disponibile a richiesta Nipple screw available upon request	Codice di ordinazione Ordering Code KITV0005
--	---

Sigla di ordinazione / Ordering code

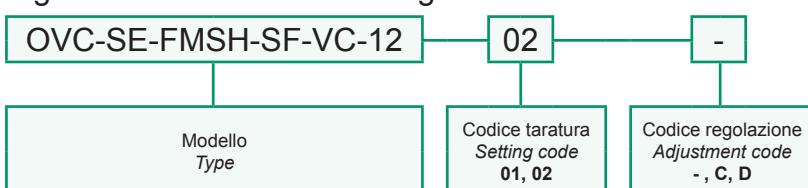

I dati non sono impegnativi, **CBF** si riserva di apportare modifiche senza preavviso.
 The specifications are not binding, **CBF** reserves the right to introduce modifications without notice.

Valvola regolatrice di flusso a tre vie prioritaria flangiabile su motori SAMHYDRAULIK AG-AR
Three ways priority flow regulator, flangeable to SAMHYDRAULIK AG-AR motors
 mod. RFP50-FMSH-VC

Corpo in alluminio
 Aluminium body

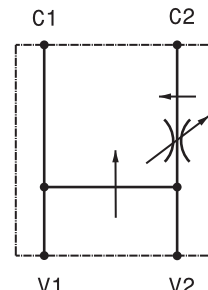
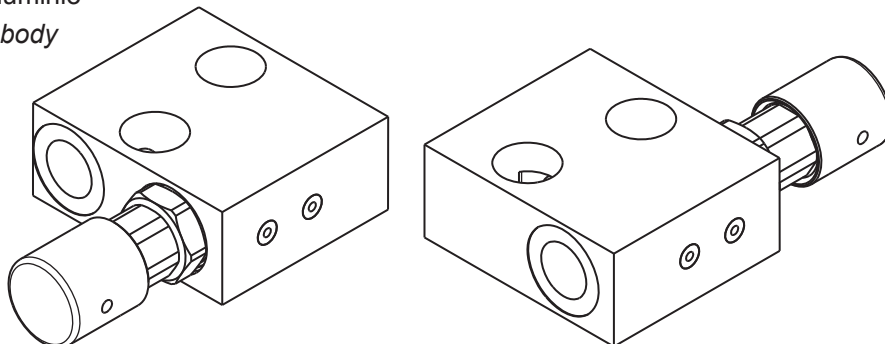

Portata massima <i>Max flow</i>	40 l/min <i>10.5 gpm</i>
Pressione massima <i>Max pressure</i>	300 bar <i>4300 psi</i>
Portata regolata <i>Regulated flow</i>	0 ÷ 25 l/min <i>0 ÷ 6.6 gpm</i>

Dati e tarature ottenuti usando olio con viscosità 30 cSt a 50°C
Performances and calibrations are carried out by using hydraulic oil with 30 cSt viscosity at 50°C

Viscosità consigliate <i>Recommended viscosity</i>	10 ÷ 420 cSt
Temperature di lavoro <i>Working temperature</i>	-20 ÷ +90 °C
Filtrazione assoluta <i>Absolute filtration</i>	25 µ

Vite cava disponibile a richiesta <i>Nipple screw available upon request</i>	Codice di ordinazione <i>Ordering Code</i>
	KITV0006

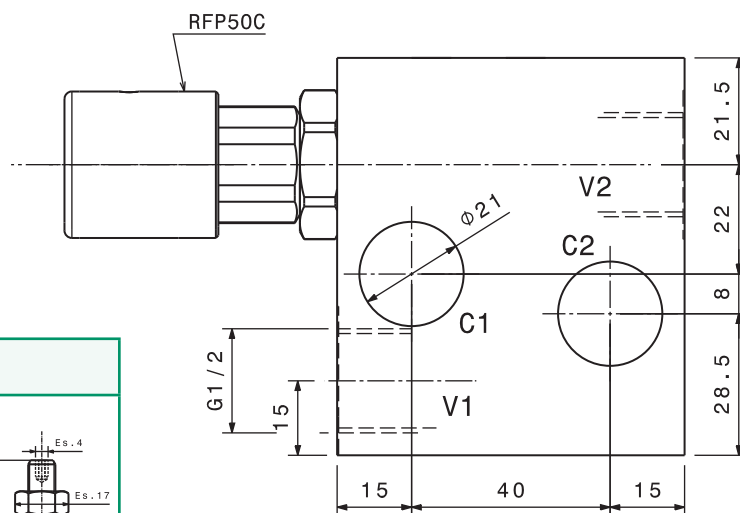
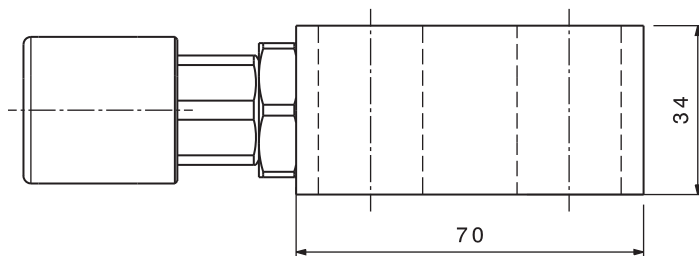

Regolazioni
Adjustments

<p>A</p> <p>Manopola con vite di bloccaggio <i>Handknob with locking screw</i></p>	<p>B</p> <p>Manopola <i>Handknob</i></p>	<p>Su richiesta <i>On request</i></p> <p>Manopola con vite di bloccaggio <i>Handknob with locking screw</i></p>
--	--	---

Sigla di ordinazione / Ordering code

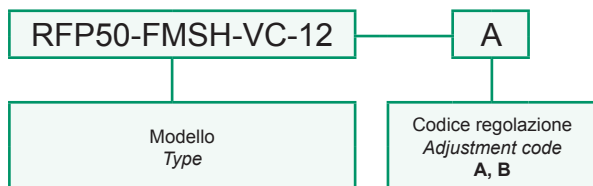

I dati non sono impegnativi, CBF si riserva di apportare modifiche senza preavviso.
The specifications are not binding, CBF reserves the right to introduce modifications without notice.

Rotodeviatore flangiabile su motori SAMHYDRAULIK AG-AR
 Rotating distributor, flangeable to SAMHYDRAULIK AG-AR motors
 mod. RTD-FMSH-VC-12

Corpo in alluminio
 Aluminium body

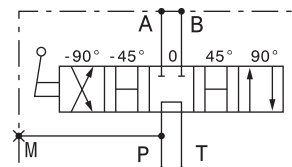
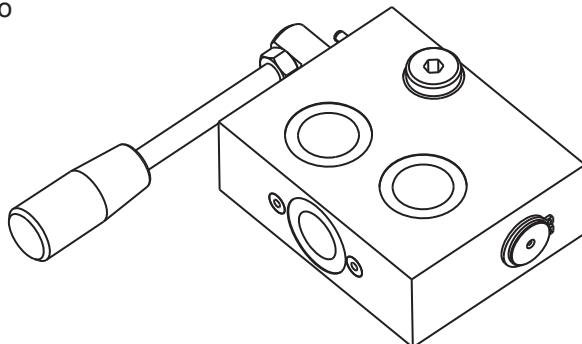

Portata massima Max flow	60 l/min 16 gpm
Pressione massima Max pressure	300 bar 4300 psi

Dati e tarature ottenuti usando olio con viscosità 30 cSt a 50°C
 Performances and calibrations are carried out by using hydraulic oil with 30 cSt viscosity at 50°C

Viscosità consigliate Recommended viscosity	10 ÷ 420 cSt
Temperature di lavoro Working temperature	-20 ÷ +90 °C
Filtrazione assoluta Absolute filtration	25 µ

Vite cava disponibile a richiesta Nipple screw available upon request	Codice di ordinazione Ordering Code
	KITV0006

Coppia di serraggio Installation torque	65 ÷ 70 Nm 49 ÷ 53 lb ft
--	-----------------------------

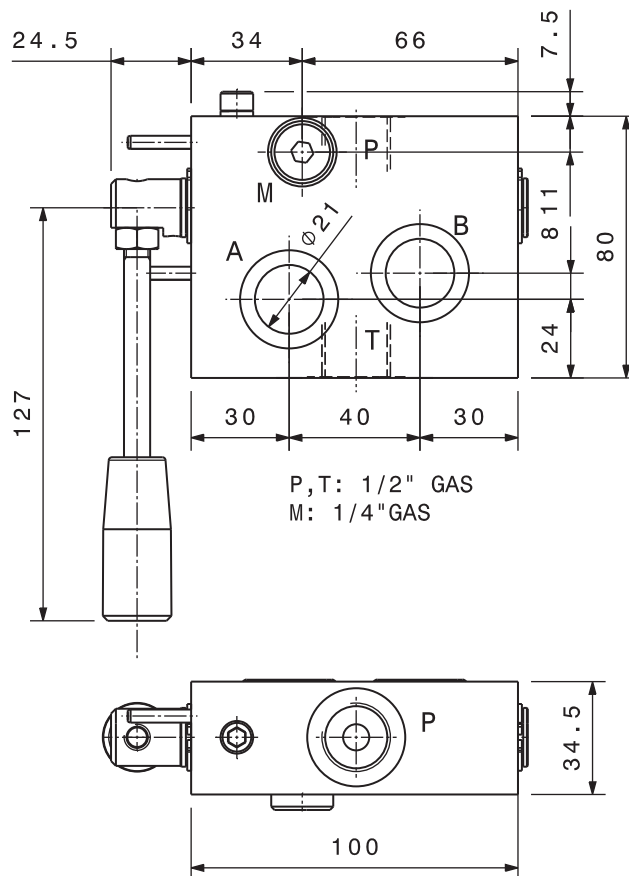

Sigla di ordinazione / Ordering code

RTD-FMSH-VC-12

Modello
Type

I dati non sono impegnativi, **CBF** si riserva di apportare modifiche senza preavviso.
 The specifications are not binding, **CBF** reserves the right to introduce modifications without notice.

Rotodeviatore con valvola limitatrice di pressione flangiabile su motori SAMHYDRAULIK AG-AR
 Rotating distributor with relief valve, flangeable to SAMHYDRAULIK AG-AR motors
 mod. RTD-FMSH-VC-VLP40-12

Corpo in alluminio
 Aluminium body

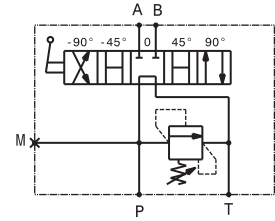
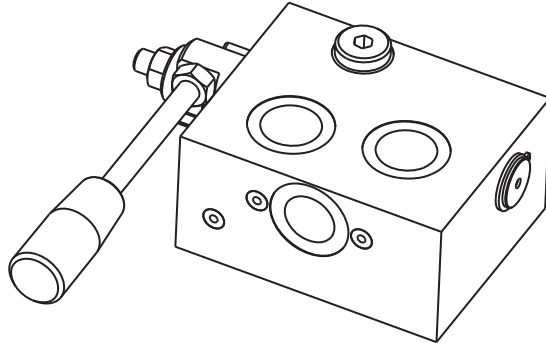

Portata massima Max flow	60 l/min 16 gpm
Pressione massima Max pressure	300 bar 4300 psi

Vite cava disponibile a richiesta Nipple screw available upon request	Codice di ordinazione Ordering Code KITV0005
---	---

Taratura Setting		
Codice Code	Taratura standard Standard setting (Q=5 l/min)	Campo di taratura Adj. Pressure range
00	40 bar 580 psi	5÷40 bar 72.5÷580 psi
01	80 bar 1160 psi	20÷100 bar 290÷1450 psi
02	180 bar 2600 psi	40÷250 bar 580÷3600 psi
03	250 bar 3600 psi	60÷350 bar 870÷5000 psi

Dati e tarature ottenuti usando olio con viscosità 30 cSt a 50°C Performances and calibrations are carried out by using hydraulic oil with 30 cSt viscosity at 50°C	
Viscosità consigliate Recommended viscosity	10 ÷ 420 cSt
Temperature di lavoro Working temperature	-20 ÷ +90 °C
Filtrazione assoluta Absolute filtration	25 µ

Regolazioni Adjustments			
A 	B 	C 	D
Vite esterna esagono incassato Leakproof hex socket screw	Volantino e dado Handknob and locknut	Piombatura Sealing cap	Cappellino Cap

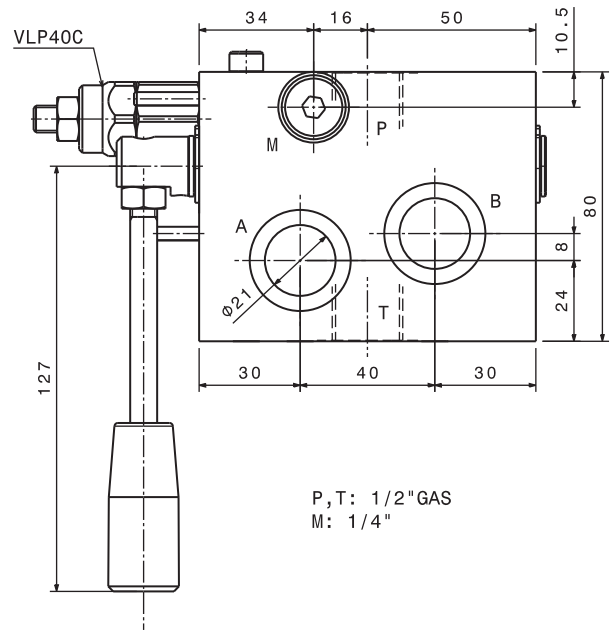

P, T: 1/2" GAS
 M: 1/4"

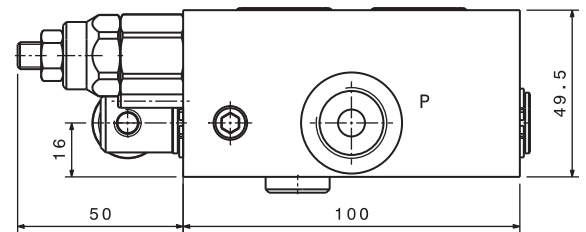

Sigla di ordinazione / Ordering code

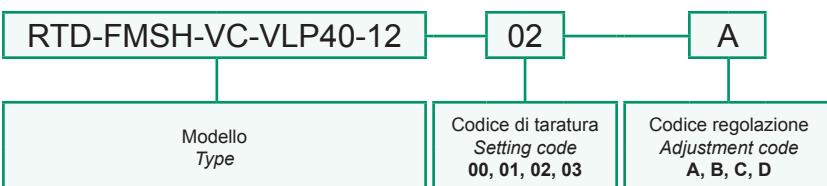

Coppia di serraggio Installation torque	80 ÷ 90 Nm 60 ÷ 67 lb ft
--	-----------------------------

I dati non sono impegnativi, **CBF** si riserva di apportare modifiche senza preavviso.
 The specifications are not binding, **CBF** reserves the right to introduce modifications without notice.

Valvola antiurto doppio effetto flangiabile su motori SAMHYDRAULIK AG-AR
Double effect antishock valve, flangeable to SAMHYDRAULIK AG-AR motors
mod. VLP40-D-FMSH-VC

Corpo in alluminio
Aluminium body

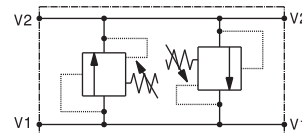
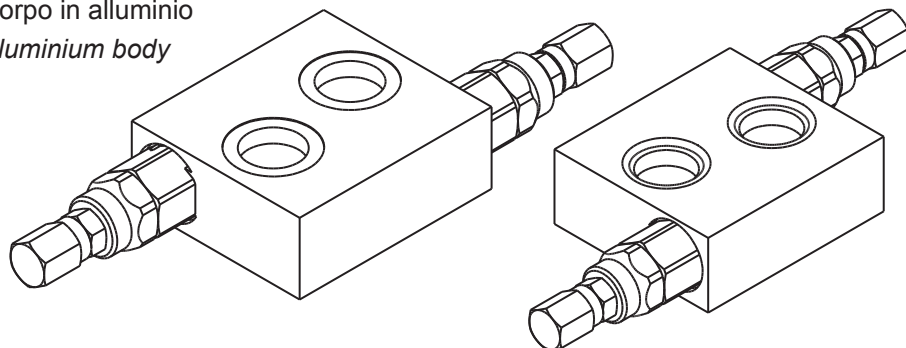

Portata massima Max flow	40 l/min 10.5 gpm
Pressione massima Max pressure	300 bar 4350 psi

Taratura Setting		
Codice Code	Taratura standard Standard setting (Q=5 l/min)	Campo di taratura Adj. Pressure range
00	40 bar 580 psi	5÷40 bar 72.5÷580 psi
01	80 bar 1160 psi	20÷100 bar 290÷1450 psi
02	180 bar 2600 psi	40÷250 bar 580÷3600 psi
03	250 bar 3600 psi	60÷350 bar 870÷5000 psi

Dati e tarature ottenuti usando olio con viscosità 30 cSt a 50°C Performances and calibrations are carried out by using hydraulic oil with 30 cSt viscosity at 50°C	
Viscosità consigliate Recommended viscosity	10 ÷ 420 cSt
Temperature di lavoro Working temperature	-20 ÷ +90 °C
Filtrazione assoluta Absolute filtration	25 µ

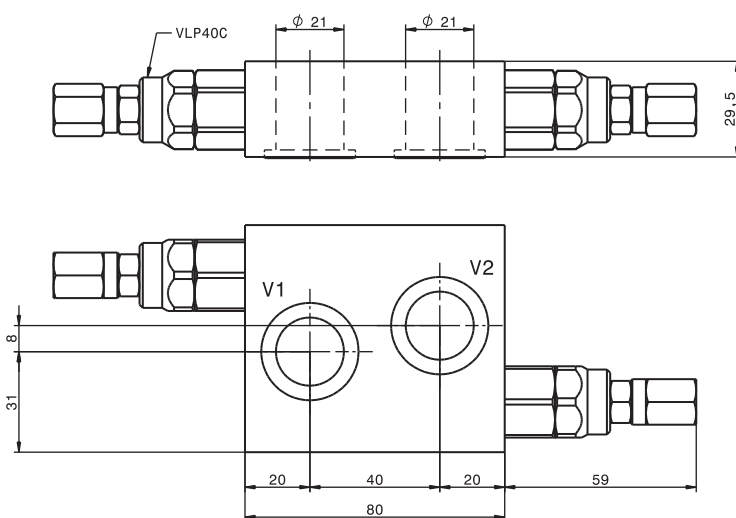

Regolazioni Adjustments			
A 	B 	C 	D
Vite esterna esagono incassato Leakproof hex socket screw	Volantino e dado Handknob and locknut	Piombatura Sealing cap	Cappello Cap

Vite cava disponibile a richiesta Nipple screw available upon request	Codice di ordinazione Ordering Code KITV0004
--	---

Sigla di ordinazione / Ordering code

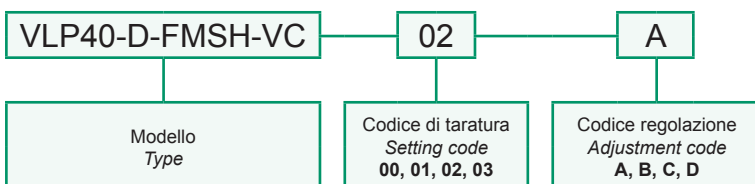

I dati non sono impegnativi, CBF si riserva di apportare modifiche senza preavviso.
The specifications are not binding, CBF reserves the right to introduce modifications without notice.

Valvola antiurto semplice effetto flangiabile su motori SAMHYDRAULIK AG-AR
Single effect antishock valve, flangeable to SAMHYDRAULIK AG-AR motors

mod. VLP40-S-FMSH-VC

Corpo in alluminio
Aluminium body

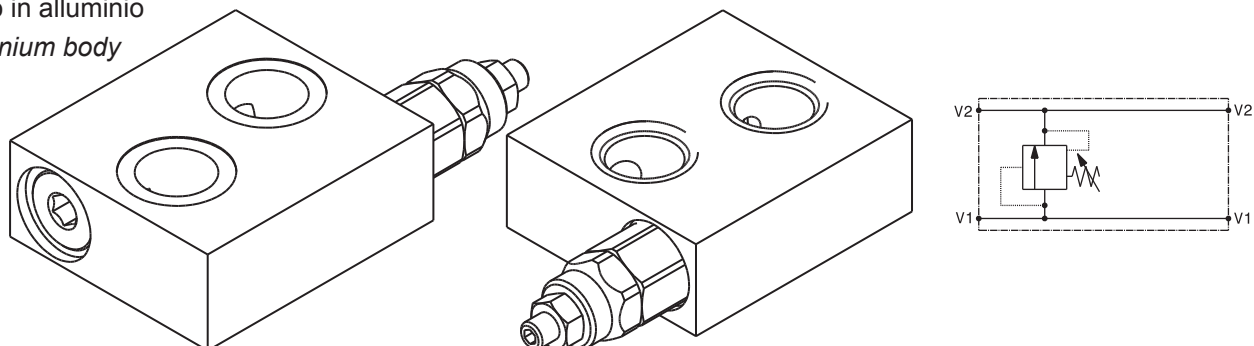

Portata massima Max flow	40 l/min 10.5 gpm
Pressione massima Max pressure	300 bar 4300 psi

Taratura Setting		
Codice Code	Taratura standard Standard setting (Q=5 l/min)	Campo di taratura Adj. Pressure range
00	40 bar 580 psi	5÷40 bar 72.5÷580 psi
01	80 bar 1160 psi	20÷100 bar 290÷1450 psi
02	180 bar 2600 psi	40÷250 bar 580÷3600 psi
03	250 bar 3600 psi	60÷350 bar 870÷5000 psi

Dati e tarature ottenuti usando olio con viscosità 30 cSt a 50°C
Performances and calibrations are carried out by using hydraulic oil with 30 cSt viscosity at 50°C

Viscosità consigliate Recommended viscosity	10 ÷ 420 cSt
Temperature di lavoro Working temperature	-20 ÷ +90 °C
Filtrazione assoluta Absolute filtration	25 µ

Regolazioni Adjustments			
A 	B 	C 	D
Vite esterna esagono incassato Leakproof hex socket screw	Volantino e dado Handknob and locknut	Piombatura Sealing cap	Cappellotto Cap

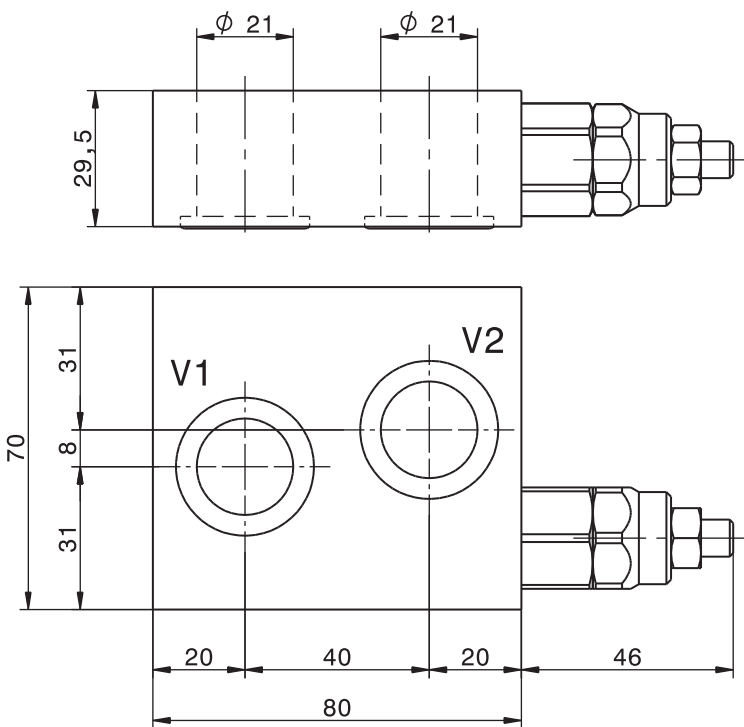

Vite cava disponibile a richiesta Nipple screw available upon request	Codice di ordinazione Ordering Code KITV0004
--	---

Sigla di ordinazione / Ordering code

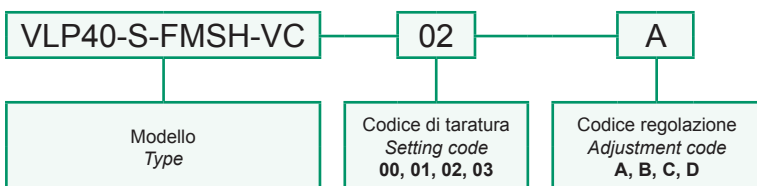

I dati non sono impegnativi, CBF si riserva di apportare modifiche senza preavviso.
The specifications are not binding, CBF reserves the right to introduce modifications without notice.

Valvola antiurto doppio effetto flangiabile su motori SAMHYDRAULIK AG-AR con sblocco freno
Double effect antishock valve with brake unclamping, flangeable to SAMHYDRAULIK AG-AR motors
mod. VLP40-D-FMSH-SF-VC

Corpo in alluminio

Aluminium body

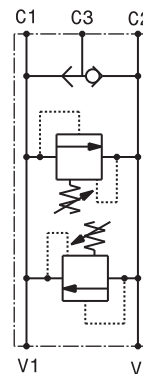
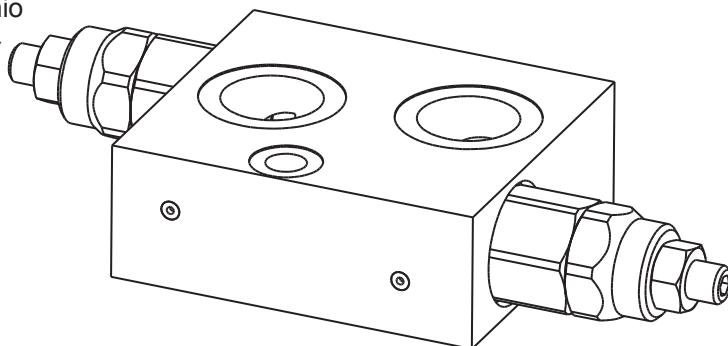

Portata massima Max flow	40 l/min 10.5 gpm
Pressione massima Max pressure	300 bar 4350 psi

Taratura Setting		
Codice Code	Taratura standard Standard setting (Q=5 l/min)	Campo di taratura Adj. Pressure range
00	40 bar 580 psi	5÷40 bar 72.5÷580 psi
01	80 bar 1160 psi	20÷100 bar 290÷1450 psi
02	180 bar 2600 psi	40÷250 bar 580÷3600 psi
03	250 bar 3600 psi	60÷350 bar 870÷5000 psi

Dati e tarature ottenuti usando olio con viscosità 30 cSt a 50°C Performances and calibrations are carried out by using hydraulic oil with 30 cSt viscosity at 50°C	
Viscosità consigliate Recommended viscosity	10 ÷ 420 cSt
Temperature di lavoro Working temperature	-20 ÷ +90 °C
Filtrazione assoluta Absolute filtration	25 µ

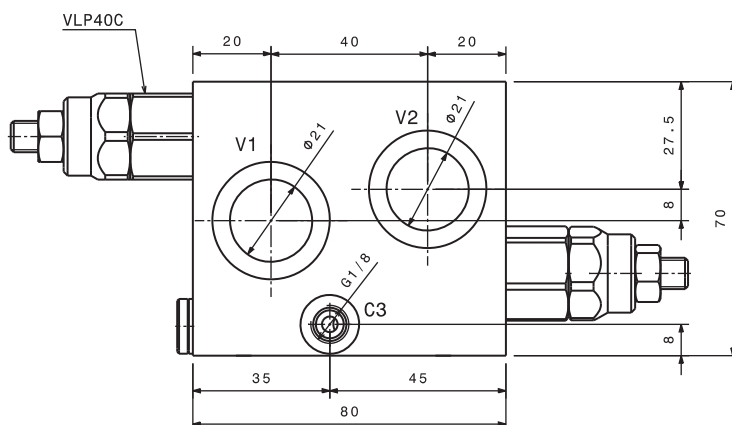
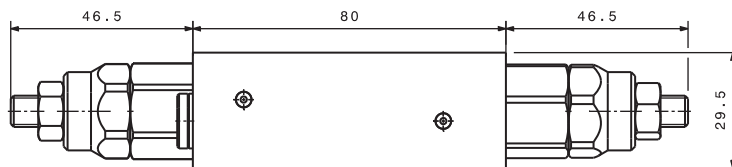

Regolazioni Adjustments			
A 	B 	C 	D
Vite esterna esagono incassato Leakproof hex socket screw	Volantino e dado Handknob and locknut	Piombatura Sealing cap	Cappello Cap

Vite cava disponibile a richiesta Nipple screw available upon request	Codice di ordinazione Ordering Code KITV0004
--	---

Sigla di ordinazione / Ordering code

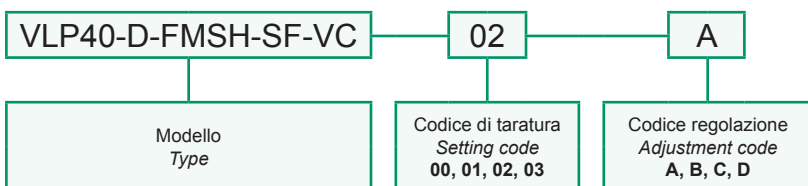

I dati non sono impegnativi, CBF si riserva di apportare modifiche senza preavviso.
The specifications are not binding, CBF reserves the right to introduce modifications without notice.

Rotodeviatore con valvola limitatrice di pressione e strozzatore flangiabile su motori SAMHYDRAULIK AG-AR
 Rotating distributor with relief and needle valve, flangeable to SAMHYDRAULIK AG-AR motors
 mod. RTD-FMSH-VC-VLP40-ST-12

Corpo in alluminio
 Aluminium body

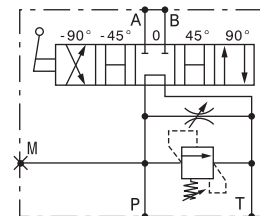
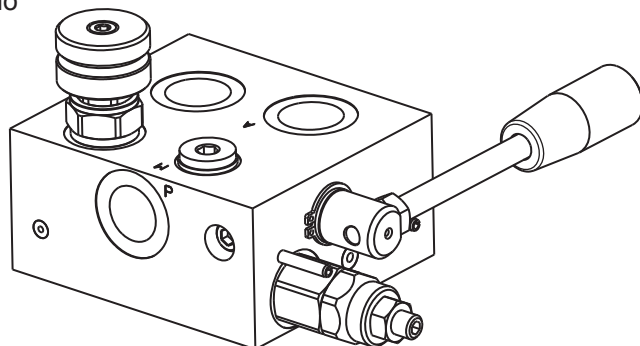

Portata massima Max flow	60 l/min 16 gpm
Pressione massima Max pressure	300 bar 4300 psi

Vite cava disponibile a richiesta Nipple screw available upon request	Codice di ordinazione Ordering Code KITV0005
--	---

Taratura Setting		
Codice Code	Taratura standard Standard setting (Q=5 l/min)	Campo di taratura Adj. Pressure range
00	40 bar 580 psi	5÷40 bar 72.5÷580 psi
01	80 bar 1160 psi	20÷100 bar 290÷1450 psi
02	180 bar 2600 psi	40÷250 bar 580÷3600 psi
03	250 bar 3600 psi	60÷350 bar 870÷5000 psi

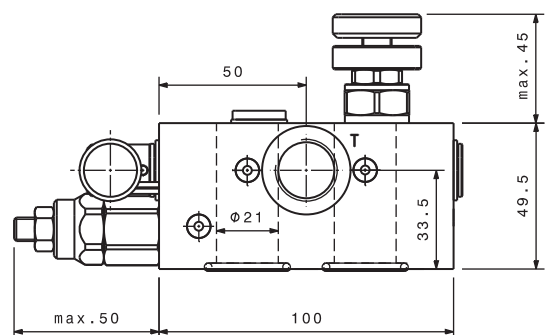

Dati e tarature ottenuti usando olio con viscosità 30 cSt a 50°C Performances and calibrations are carried out by using hydraulic oil with 30 cSt viscosity at 50°C	
Viscosità consigliate Recommended viscosity	10 ÷ 420 cSt
Temperature di lavoro Working temperature	-20 ÷ +90 °C
Filtrazione assoluta Absolute filtration	25 µ

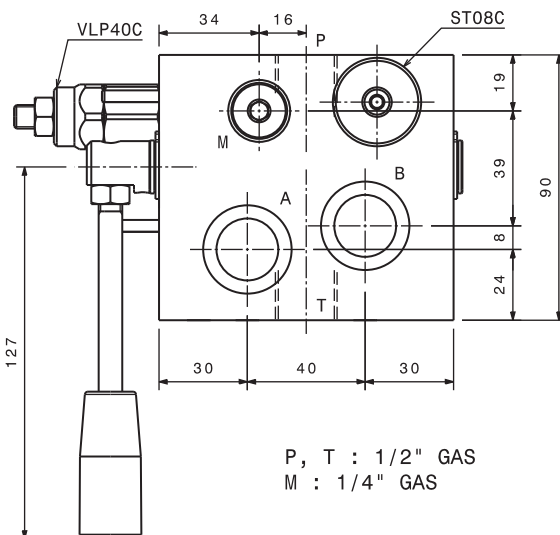

Regolazioni Adjustments			
A Vite esterna esagono incassato Leakproof hex socket screw	B Volantino e dado Handknob and locknut	C Piombatura Sealing cap	D Cappello Cap

Sigla di ordinazione / Ordering code

RTD-FMSH-VC-VLP40-ST-12 — 02 — A

Modello Type	Codice di taratura Setting code 00, 01, 02, 03	Codice regolazione Adjustment code A, B, C, D
-----------------	--	---

Coppia di serraggio Installation torque	80 ÷ 90 Nm 60 ÷ 67 lb ft
--	-----------------------------

I dati non sono impegnativi, CBF si riserva di apportare modifiche senza preavviso.
 The specifications are not binding, CBF reserves the right to introduce modifications without notice.

LubeTeam Hydraulic S.r.l.

Administration and Headquarter:

Via Tufara Scautieri, 6
83018 - San Martino Valle Caudina (AV)

Office and Warehouse:

S.S. 7 Appia, Km. 237,00

82011 - Airola BN

ITALY

Tel. +39 0823 950 994

Fax +39 0823 412 546

www.lubeteam.it info@lubeteam.it

Italian VAT / C.F. e P.IVA: 01251720627

Follow us



This document is the property of LubeTeam Hydraulic S.r.l. All data reported here are for the exclusive use of the Receiver. Reproduction is not authorized without writing permission, in all or in part of the content of this document, in accordance to Law 633 art. 171, dated April 22, 1941.

Il presente documento è di proprietà della LubeTeam Hydraulic S.r.l. I dati riportati sono per esclusivo del destinatario. La riproduzione, di tutto o in parte, non è autorizzata senza permesso scritto secondo l'art. 171 della L. 633 del 22 Aprile 1941.