



EMMEGI

Scambiatori di calore Aria/Olio
Serie 2000 KBV



 HYDRAULIC
COMPONENTS
& FLUID CONTAMINATION
CONTROL



All trademarks belong to their respective owners; third party trademarks, product names, trade names, corporate names and company names mentioned may be trademarks of their respective owners or registered trademarks of other companies and are used for instructional purposes and for the benefit of the owner, without any end of Copyright infringement in force.

Tutti i marchi riportati appartengono ai legittimi proprietari; marchi di terzi, nomi di prodotti, nomi commerciali, nomi corporativi e società citati possono essere di proprietà dei rispettivi titolari o registrati da altre società e sono stati utilizzati a puro scopo esplicativo e a beneficio del possessore, senza alcun fine di violazione dei diritti di Copyright vigenti.

Scambiatori Aria-olio Serie 2000KBV

*Air-oil heat-exchangers
2000KBV Series*

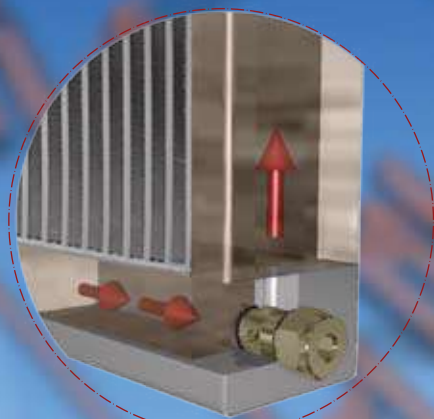

ENNECI

Gli scambiatori di calore aria-olio EMMEGI, sono impiegati per il raffreddamento di circuiti oleodinamici usando, come fluido raffreddante, l'aria ambiente convogliata sulla radiante da una ventola azionata da un motore elettrico o idraulico. La massa radiante, in lega d'alluminio ad alta resistenza, è ottenuta mediante un processo costruttivo di saldobrasatura sottovuoto. La particolare configurazione dei condotti aumenta la turbolenza del fluido e di conseguenza la capacità di scambio; inoltre la presenza di speciali turbolatori sull'alettatura del pacco radiante, migliora ulteriormente il coefficiente di trasmissione totale. Il risultato è un prodotto tecnologicamente avanzato di dimensioni contenute, leggero e robusto. Gli scambiatori aria-olio serie KBV- nascono dalle esigenze applicative ad ampio raggio espresse dal mercato. Punto di forza di questi prodotti è rappresentato dal by-pass integrato che ne amplifica la semplicità d'uso, eliminando la necessità di dovere aggiungere da parte del cliente una valvola autonoma, assicurando così elevata funzionalità.

Fluidi compatibili

- . OIL MINERALI, HL, HLP.
- . EMULSIONI ACQUA-OLIO
- . ACQUA-GLICOLE
- . Per altri fluidi consultare EMMEGI.

Specifiche tecniche Masse Radianti

- . Materiale: alluminio "long life".
- . Pressione d'esercizio: 20 bar.
- . Pressione di collaudo: 35 bar.
- . Temperatura max d'esercizio: 120°C
- . Per particolari atmosfere aggressive consultare l'EMMEGI.

Installazione

Lo scambiatore può essere montato in posizione orizzontale o verticale, rispettando la distanza minima dalla parete (vedi fig. 1), in modo da assicurare un naturale afflusso e deflusso dell'aria di raffreddamento.

Lo scambiatore è installato di norma, sulle tubazioni di ritorno dell'olio del serbatoio; deve inoltre essere protetto da urti e vibrazioni meccaniche mediante supporti e collegato all'impianto con tubazioni flessibili. È necessario evitare che sia sottoposto a brusche variazioni di portata, colpi d'ariete e pulsazioni continue che danneggiano in modo irreversibile la radiante.

Per preservare lo scambiatore dalla sovrappressione che si genera all'avviamento dell'impianto per elevata viscosità dell'olio, si suggerisce l'inserimento di una valvola di by-pass (vedi fig.2).

EMMEGI air-oil heat exchangers are used for cooling oil hydraulic systems using as the coolant ambient air that passes over the radiant by means of a fan operated by an electric or hydraulic motor. The cooler element, in high resistance aluminium alloy, is obtained by means of a braze-welding process carried out under vacuum.

The particular configuration of the cooling pipes increase the turbulence of the fluid consequently of the exchange capacity; moreover, the presence of special jets on the cooler finning further improves the total transmission coefficient.

The result is a very small, light and robust technologically advanced product.

The air-oil heat-exchangers KBV Series were born to answer the large application needs of the market. The main characteristic of this new products is the integrated by-pass valve that will simplify their employ and will avoid the customers to add an external and independent valve. This will guarantee a very high efficiency.

Compatible fluids

- . MINERAL OILS; HL; HLP.
- . WATER-OIL EMULSION.
- . WATER-GLYCOL.
- . Consults EMMEGI for other fluids.

Technical specification of Cooler Element

- . Material: "long life" aluminium.
- . Operating pressure: 20 bar
- . Test pressure: 35 bar.
- . Max operating temperature: 120°C.
- . For specially "aggressive" atmospheres contact EMMEGI.

Installation

The exchangers can be fitted in a horizontal position, respecting the minimum distance from the wall (see fig.1) so as to ensure a natural flow of cooling air.

The exchangers is usually installed on oil tank return piping; it must also be protected from impacts and mechanical vibrations by supports and must be connected to the plant with flexible pipes.

Avoid subjecting the exchanger to sudden changes in flow, hammering and pulsations that can cause irreversible damage to the element.

We recommend installing a by-pass valve (see fig.2) to protect the exchanger from over-pressure generated when the plants is started up due to high oil viscosity.

Manutenzione

È buona norma prestare particolare attenzione alla pulizia della massa radiante per garantire un naturale ricambio d'aria, ed evitare una diminuzione dell'efficienza termica.

Pulizia lato olio

Per eseguire la pulizia lato olio, lo scambiatore dovrà essere smontato. Lo sporco può essere rimosso flussando in controcorrente un prodotto sgrassante, compatibile con alluminio. Effettuate un lavaggio con olio idraulico prima di ricollegare il prodotto all'impianto.

Pulizia lato aria

La pulizia lato aria può essere effettuata con aria compressa o acqua, con direzione del getto parallelo alle alette per non danneggiare. Lo sporco oleoso o grasso può essere rimosso con getto di vapore o acqua calda. Durante questa operazione, il motore elettrico non deve essere collegato alla tensione, e dovrà essere adeguatamente protetto.

Esempio di scelta dello scambiatore

Per effettuare la scelta dello scambiatore si procede come segue:

Potenza da dissipare : 8,7 [KW]
Portata olio ISO VG 32 : 90 [lpm]
Temperatura ingresso olio : 60 [°C]
Temperatura ambiente : 30 [°C]
Ventola azionata da motore elettrico 230/400V-50Hz.

Si calcola la potenza specificata di scambio espressa in $KW/°C$, conoscendo la potenza da dissipare e il ΔT (differenza tra la temperatura olio ingresso e la temperatura ambiente).

$$P = \frac{8.7 \text{ KW}}{60^\circ - 30^\circ} = 0.29 \text{ KW}/^\circ\text{C}$$

Nota la portata olio (90 lpm) e la potenza specifica di scambio ($0.29 \text{ KW}/^\circ\text{C}$) si procede alla ricerca del prodotto avvalendosi dei grafici riportati a catalogo, relativi ai singoli modelli.

Maintenance

You should be particularly carefully in cleaning the cooler element to guarantee a natural exchange of air, in order to prevent a reduction in thermal efficiency

Cleaning oil side

The exchanger should be dismantled to clean on the oil side. The dirt can be removed by flushing, in counter-current, de-greasing substance, compatible with aluminium. Wash with hydraulic oil before re-connecting the product to the plant.

Cleaning air side

Cleaning on the air side can be done using compressed air or water, directing the jet parallel to the fins so as not to damage them. Oily dirt or grease can be removed with a jet of steam or hot water. During this operation, the electric motor must be disconnected from the voltage supply, and must be adequately protected.

Example of how to choose a heat exchanger

Proceed with sizing the exchanger, with a knowledge of the data as the example below shows:

Power to dissipate : 8,7 [KW]
ISO VG 32 oil flow : 90 [lpm]
Oil input temperature : 60 [°C]
Ambient temperature : 30 [°C]
Fan operating with an electric motor 230/400V-50Hz.

You can then calculate the specific heat exchange power $KW/°C$ if you know the power to dissipate and the ΔT (the difference between the oil input temperature and the ambient temperature).

$$P = \frac{8.7 \text{ KW}}{60^\circ - 30^\circ} = 0.29 \text{ KW}/^\circ\text{C}$$

Note the oil flow (90 lpm) and specific exchange power ($0.29 \text{ KW}/^\circ\text{C}$), product research is made by referring to the graph in the catalogue which is relevant to each model.

P/N	V	Hz	kW(±10%)	A (±10%)	rpm	ø Fan	dB(A)	(m³/h)	IP	lt	Kg
2W3001 ###	230AC	50/60	0,23 - 0,35	1,1 - 1,55	2700/3000	300	78	2220	44	1,6	15
2W3003 ###	230-400 AC	50	0,21	0,62 - 0,36	2580	300	76	2500	44		15
	230-400 AC	60	0,30	0,84 - 0,48	2750						15
2W3004 ###	230-400 AC B14	50	0,37	2,1 - 1,1	1370	300	70	1850	55		20
	265-460 AC B14	60	0,43	2,1 - 1,1	1650						20
2W3012 ###	12 DC	/	0,16	13,3	2660	305	80	1675	67		14
2W3024 ###	24 DC	/	0,18	7,4	2870	305	83	1880	67	14	
2W3056 ###	Prepared for Gr.2 hydraulic motor					300			/	15	

Contattare EMMEGI Contact EMMEGI

Diagramma rendimento Performance diagram

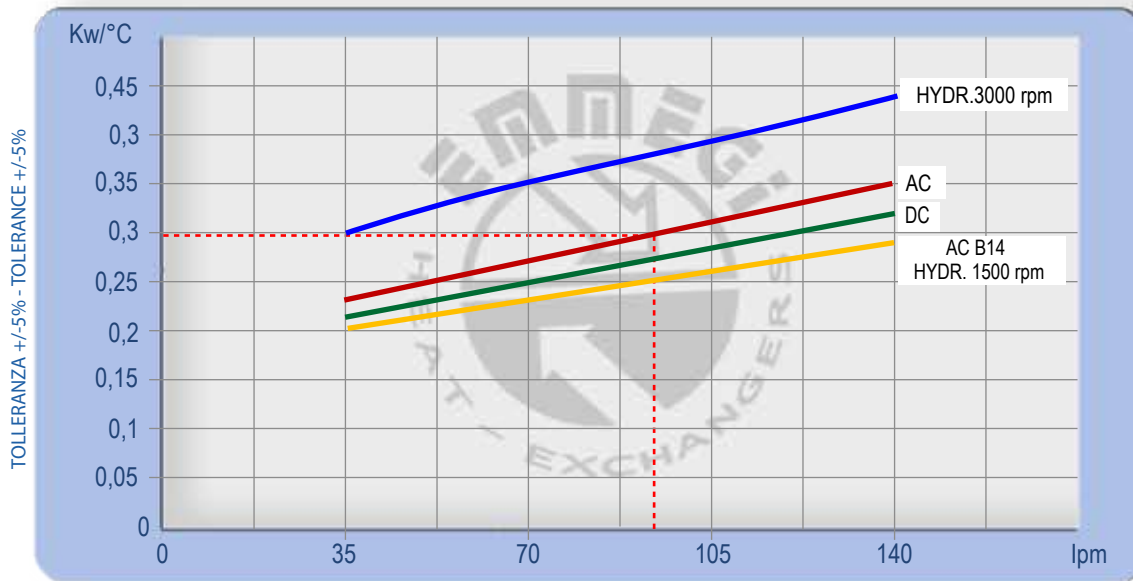

Lo scambiatore selezionato risulta il modello:
MG AIR 2030KBV - 230/400 - 50Hz
cod. 2W3003###.

The exchanger selected is the following model:
MG AIR 2030KBV - 230/400V - 50Hz
cod. 2W3003###.

Per la completa identificazione dello scambiatore consultare la pagina "DENOMINAZIONE CODICE PRODOTTO". Nel caso non siano conosciuti tutti i dati, per la scelta prendere contatto **EMMEGI**.

For a complete description of the exchanger consult the "PRODUCT ORDERING CODE" page. If you do not know all the data required for selecting the model, contact **EMMEGI**.

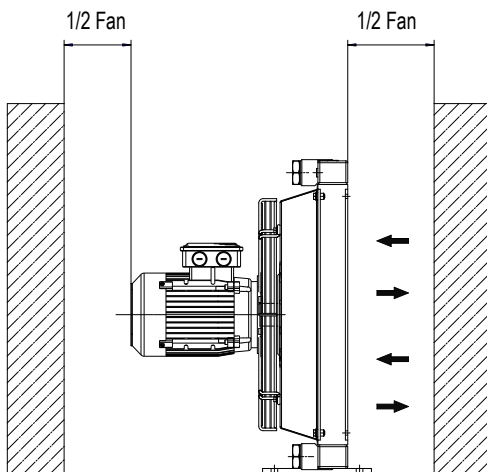

Fig.1

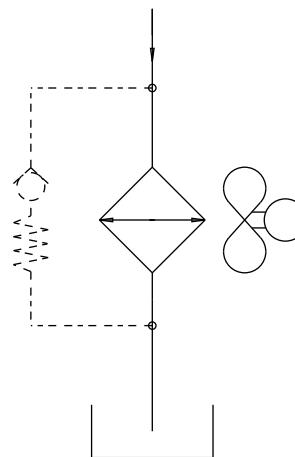
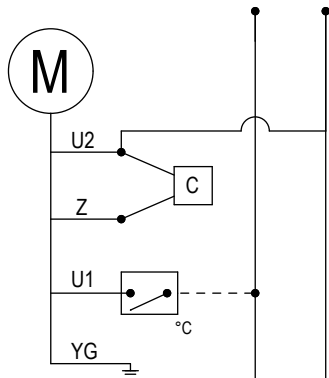

Fig.2

Collegamenti elettrici

Electric Wiring

COLLEGAMENTO ELETTRICO 230V MON. AC
230V AC MON. ELECTRIC WIRING



YG=TERRA/GROUND
 U1= BLU/BLUE
 U2= NERO/BLACK
 Z = MARRONE/BROWN
 C = CONDENSATORE/CAPACITOR
 °C= TERMOSTATO/THERMOSTAT

COLORAZIONE CAVI SOLO PER ELETTROVENTOLE EBM-PAPST
WIRES COLORS ONLY FOR EBM-PAPST AXIAL MOTOR FANS

COLLEGAMENTO ELETTRICO 12-24V DC
12-24V DC ELECTRIC WIRING

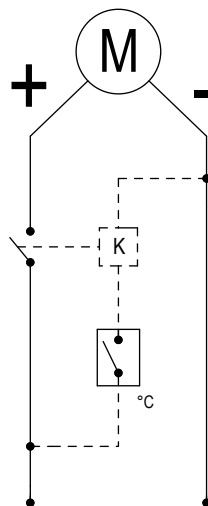

K= RELE'/RELAY
 °C TERMOSTATO/THERMOSTAT

COLLEGAMENTO ELETTRICO 230V AC TRIF.
230V AC THREEPHASE ELECTRIC WIRING

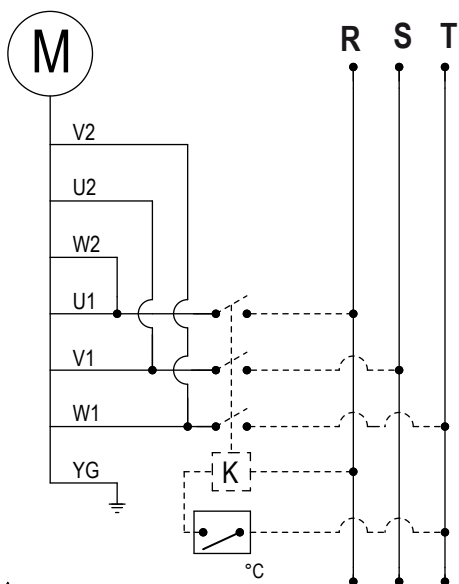

△ 230V AC 3 PHASE

U1= NERO/BLACK U2= VERDE/GREEN
 V1= BLU/BLUE V2= BIANCO/WHITE
 W1= MARRONE/BROWN W2= GIALLO/YELLOW
 YG= TERRA/GROUND K= RELE'/RELAY
 °C TERMOSTATO/THERMOSTAT

COLORAZIONE CAVI SOLO PER ELETTROVENTOLE EBM-PAPST
WIRES COLORS ONLY FOR EBM-PAPST AXIAL MOTOR FANS

COLLEGAMENTO ELETTRICO 400V AC TRIF.
400V AC THREEPHASE ELECTRIC WIRING

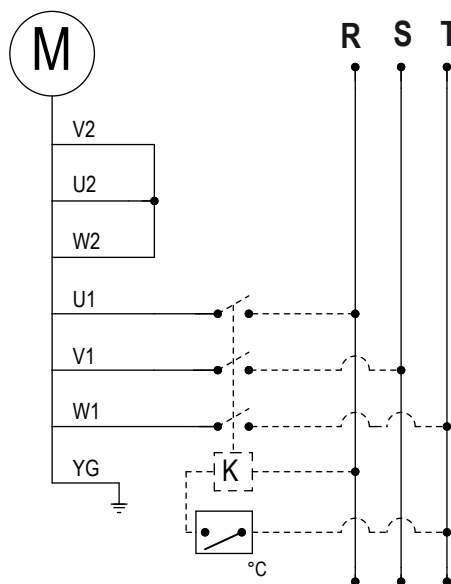

△ 400V AC 3 PHASE

U1= NERO/BLACK U2= VERDE/GREEN
 V1= BLU/BLUE V2= BIANCO/WHITE
 W1= MARRONE/BROWN W2= GIALLO/YELLOW
 YG= TERRA/GROUND K= RELE'/RELAY
 °C TERMOSTATO/THERMOSTAT

COLORAZIONE CAVI SOLO PER ELETTROVENTOLE EBM-PAPST
WIRES COLORS ONLY FOR EBM-PAPST AXIAL MOTOR FANS

Modulo richiesta dati

Sheet for cooler selection



CLIENTE COMPANY	
RICHIEDENTE NAME	

ARIA-OLIO AIR-OIL

PORTATA OLIO OIL FLOW RATE	lpm	
POTENZA INSTALLATA TOTAL POWER	KW	
POTENZA DA DISSIPARE POWER TO BE DISSIPATED	KW	
TEMPERATURA INGRESSO OLIO OIL TEMPERATURE INLET	°C	
TEMPERATURA ARIA MAX MAX AMBIENT TEMPERATURE	°C	
VISCOSITÀ OLIO OIL VISCOSITY	cst	
PRESSIONE DI LAVORO WORKING PRESSURE	bar	

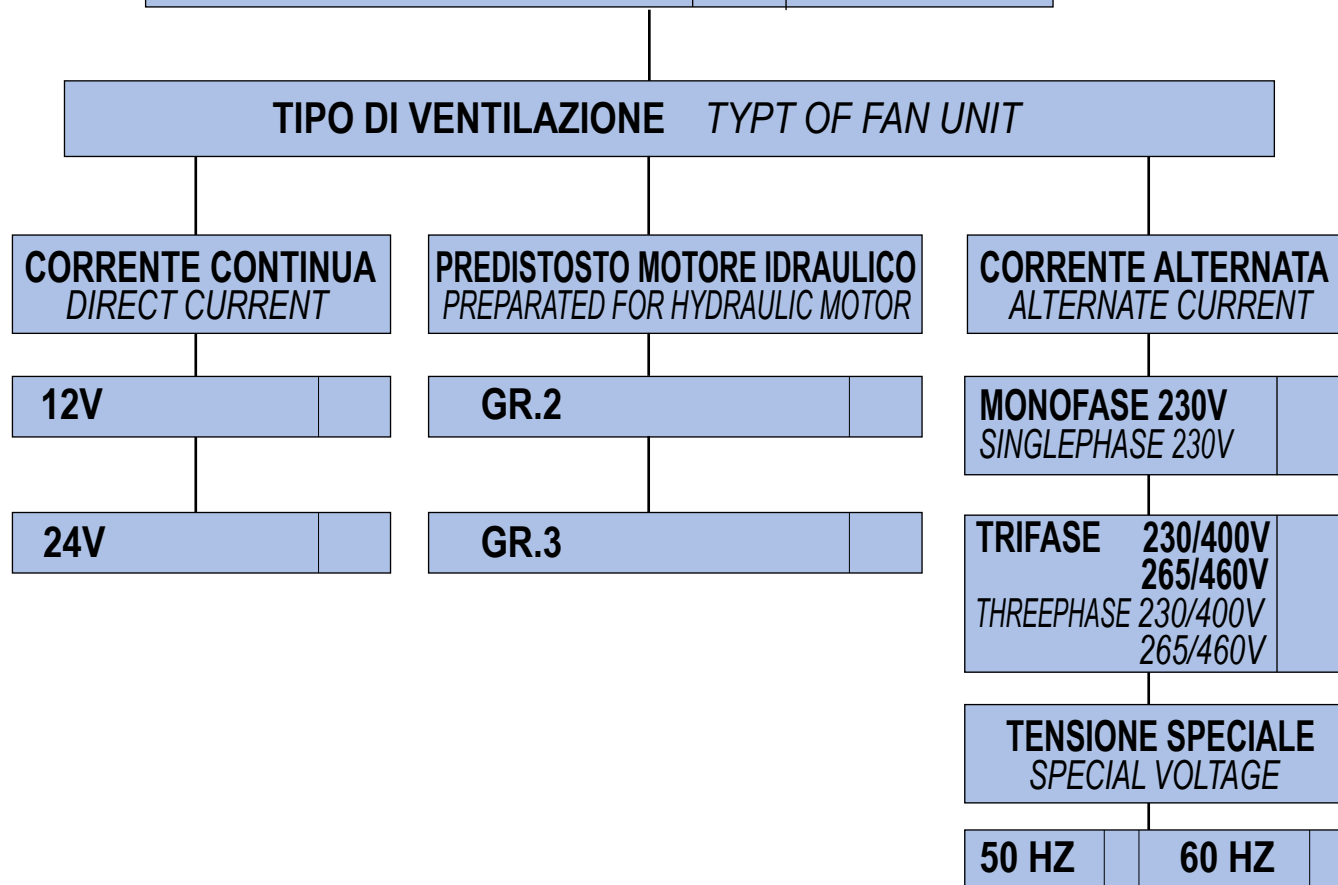

2

W24

03

2

01

TIPO DI SISTEMA COOLER SERIES

W24 (MG AIR 2024KBV)

TIPO DI MOTORIZZAZIONE FAN MOTOR TYPE

- 01 AC 230V 50 Hz
- 03 AC 230V-400V-50Hz / AC 230-400V-60Hz
- 04 AC 230V-400V-50Hz (B14) / AC 265V-460V- 60Hz (B14)
- 12 DC 12V
- 24 DC 24V
- 56 Pred. per mot. idr. gr. 2 Prep. for hydr. mot. gr. 2

TERMOSTATI THERMOSTATS

- | | | | |
|---|---------------------------------|---------------------------------|--------------|
| 1 | Termostato fisso | Fixed thermostat | 40-28° |
| 2 | Termostato fisso | Fixed thermostat | 50-38° |
| 3 | Termostato fisso | Fixed thermostat | 60-48° |
| 4 | Termostato fisso | Fixed thermostat | 70-58° |
| 5 | Termostato fisso | Fixed thermostat | 80-68° |
| 6 | Termostato fisso | Fixed thermostat | 90-78° |
| 8 | Termostato regolabile | Adjustable thermostat | 0-90° (TC2) |
| 9 | Termostato regolabile collegato | Connected adjustable thermostat | 0-120° (TC2) |

TIPO DI VENTILAZIONE VENTILATING TYPE

- 01 Aspirante Suction air flow
- 02 Soffiante Blowing air flow

Dati tecnici valvola by-pass Technical data by-pass valve - (1.5 bar)

Valvola cartuccia tipo 2 / Cartridge valve type 2 - (1.5 bar)

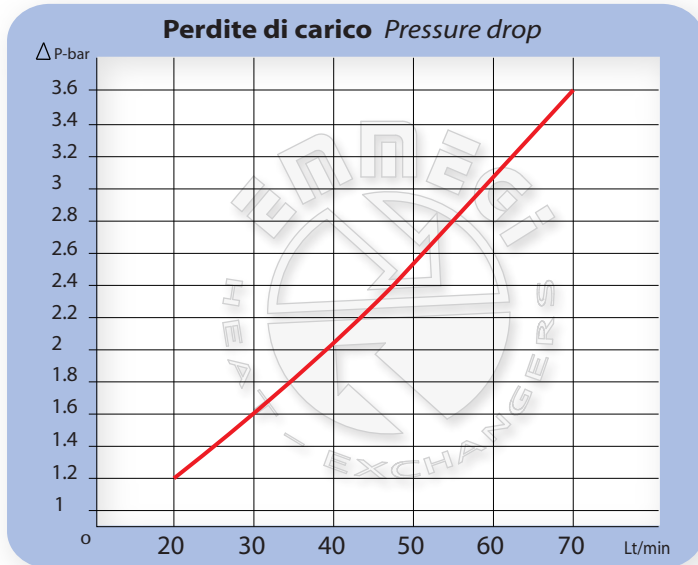

Schema idraulico Hydraulic circuit

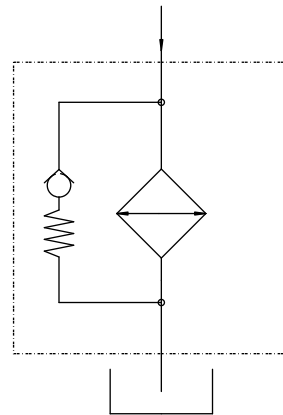

Gli scambiatori aria-olio serie KBV- nascono dalle esigenze applicative ad ampio raggio espresse dal mercato. Punto di forza di questi prodotti é rappresentato dal by-pass integrato che ne amplifica la semplicità d' uso, eliminando la necessità di dovere aggiungere da parte del cliente una valvola autonoma, assicurando così elevata funzionalità.

The air-oil heat-exchangers KBV Series were born to answer the large application needs of the market. The main characteristic of this new products is the integrated by-pass valve that will simplify their employ and will avoid the customers to add an external and independent valve. This will guarantee a very high efficiency.

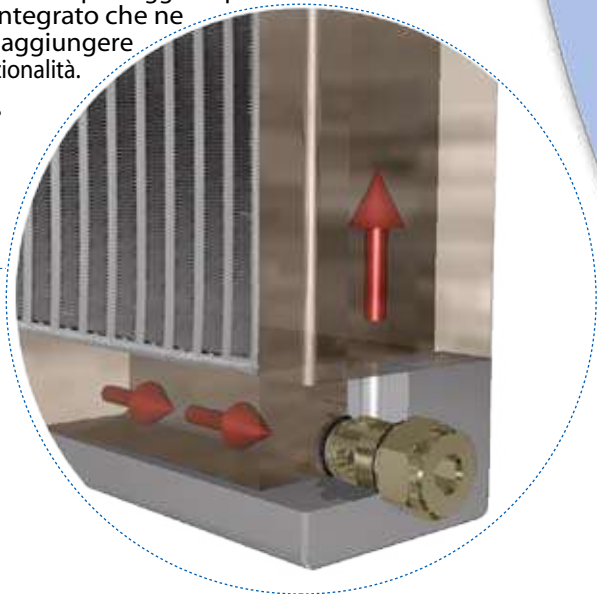

Detail



Dimensioni Dimensions

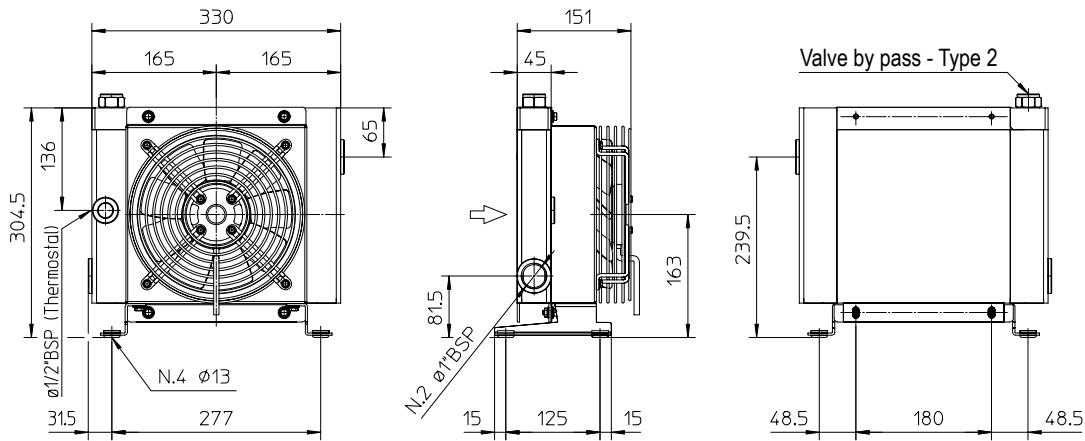

P/N 2W1501###
P/N 2W1503###

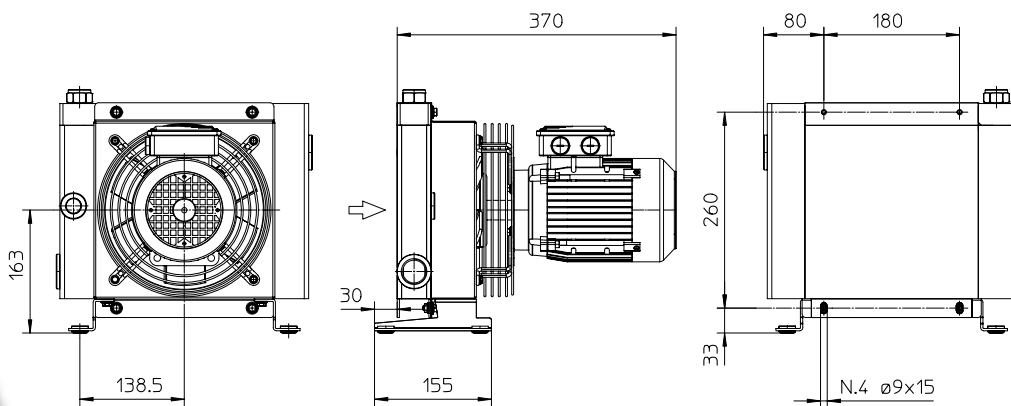

P/N 2W1504###

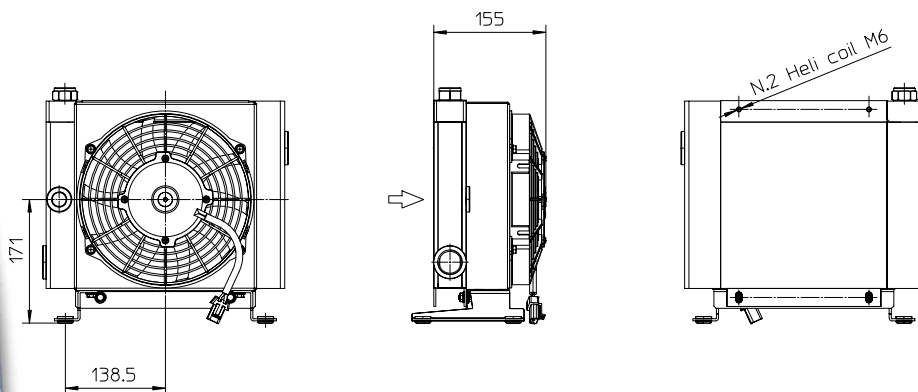

P/N 2W1512###
P/N 2W1524###

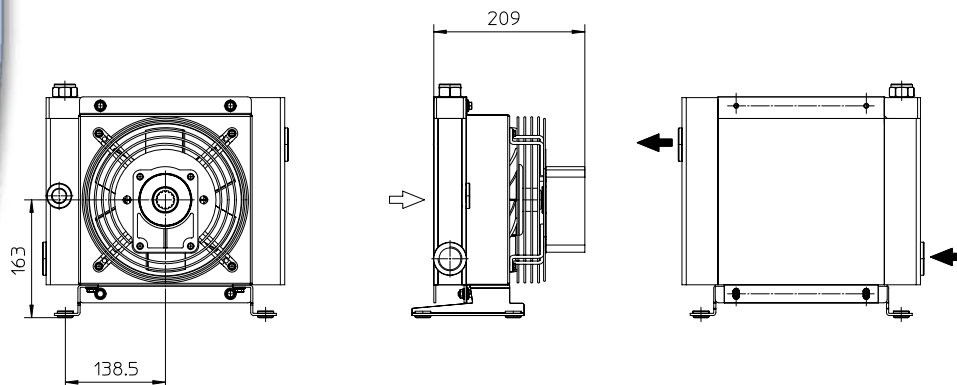

P/N 2W1556###

Le dimensioni di ingombro e le caratteristiche tecniche non sono impegnative
Over-all dimensions and technical characteristic are not binding

MG2015KBV

Dati tecnici Technical Data



P/N	V	Hz	kW(±10%)	A (±10%)	rpm	ø Fan	dB(A)	(m³/h)	IP	lt	Kg
2W1501 ###	230AC	50/60	0,050/0,061	0,24 - 0,28	2740/3120	200	68	700	44	0,5	7
2W1503 ###	230-400 AC	50	0,068	0,29 - 0,17	2500	200	69	720	44		7
	230-400 AC	60	0,070	0,23 - 0,13	2650						7
2W1504 ###	230-400 AC B14	50	0,25	1,7 - 1	1350	200	61	415	55		10
	265-460 AC B14	60	0,29	1,7 - 1	1620						10
2W1512 ###	12 DC	/	0,08	6,4	2770	225	72	790	67		6,5
2W1524 ###	24 DC	/	0,09	3,9	2900	225	73	865	67		6,5
2W1556 ###	Prepared for Gr.2 hydraulic motor					200			/	6	

Contattare EMMEGI Contact EMMEGI

Diagramma rendimento Performance diagram

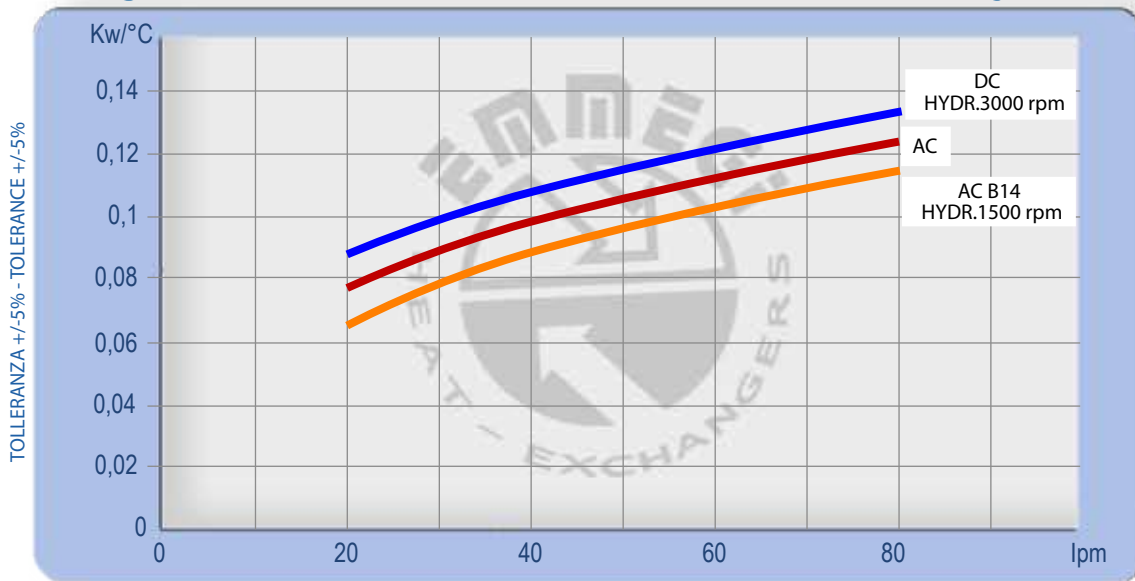

Perdite di carico Pressure drop (ISO VG 32)

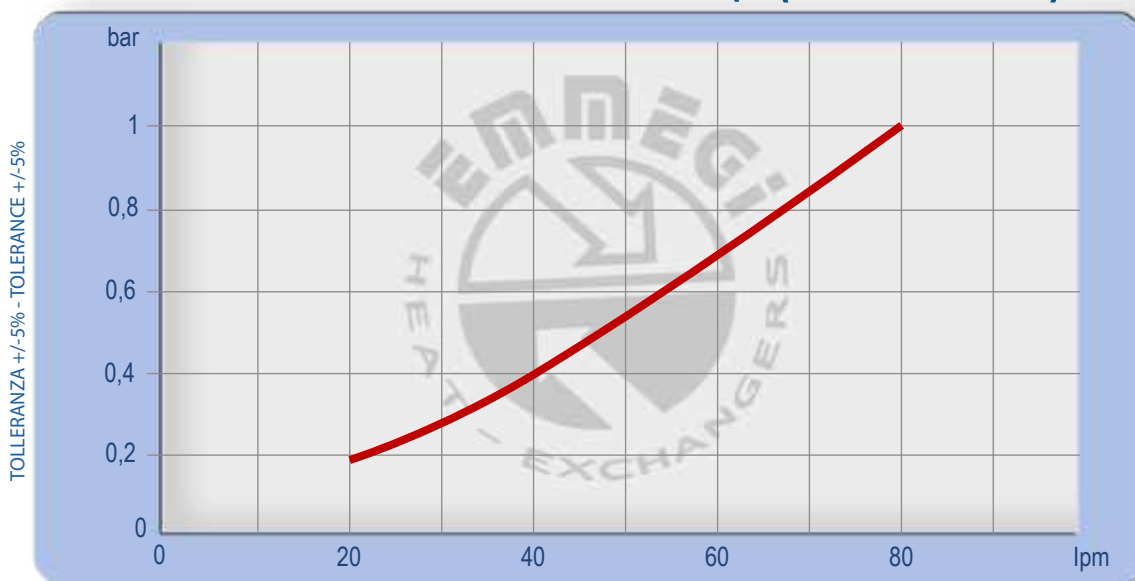

Fattore di correzione - F - (perdite di carico) Correction factor - F - (Pressure drop)

cst	10	15	20	30	40	50	60	80	100	200	300
F	0,5	0,65	0,77	1	1,2	1,4	1,6	1,9	2,1	3,3	4,3

Dimensioni Dimensions

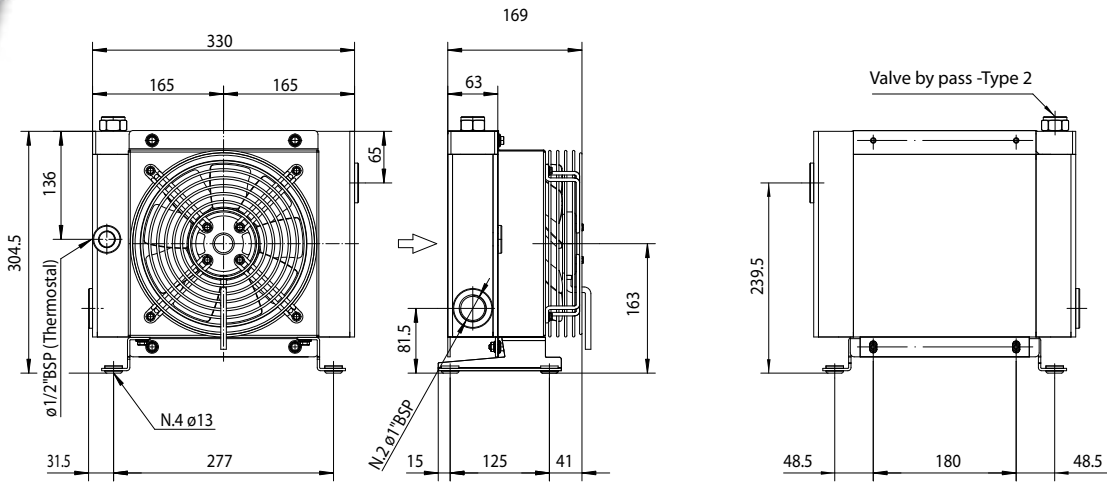

P/N 2W2001###
P/N 2W2003###

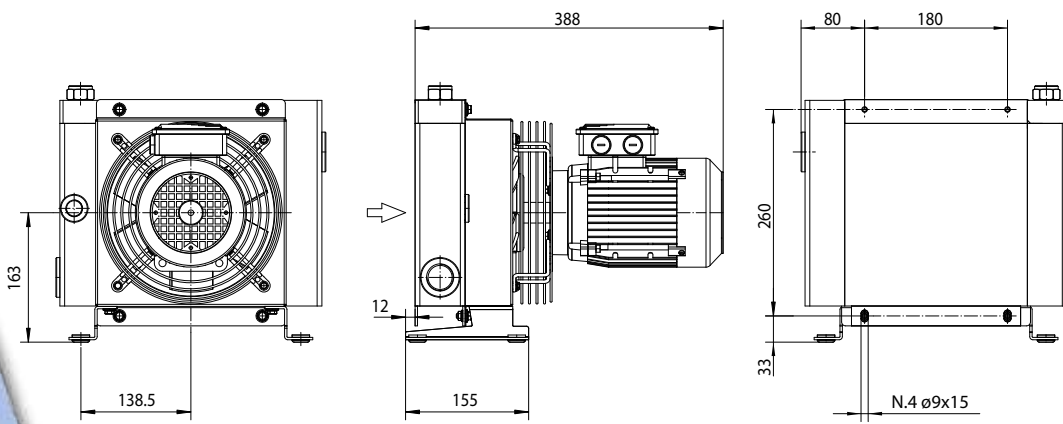

P/N 2W2004###

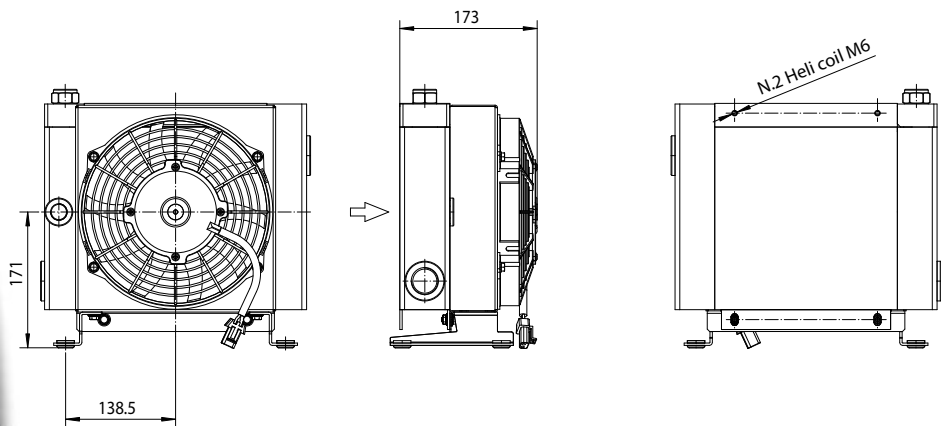

P/N 2W2012###
P/N 2W2024###

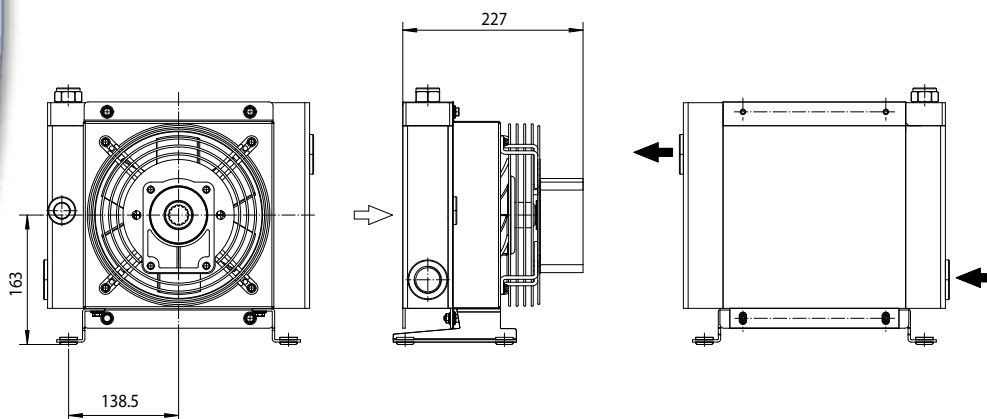

P/N 2W2056###

Le dimensioni di ingombro e le caratteristiche tecniche non sono impegnative
Over-all dimensions and technical characteristic are not binding

MG2020KBV

Dati tecnici Technical Data



P/N	V	Hz	kW(±10%)	A (±10%)	rpm	ø Fan	dB(A)	(m³/h)	IP	lt	Kg
2W2001 ###	230AC	50/60	0,050 - 0,061	0,24 - 0,28	2740/3120	200	68	675	44	0,7	8
2W2003 ###	230-400 AC	50	0,068	0,29 - 0,17	2500	200	68	645	44		8
	230-400 AC	60	0,070	0,23 - 0,13	2650						
2W2004 ###	230-400 AC B14	50	0,25	1,7 - 1	1350	200	64	390	55		11
	265-460 AC B14	60	0,29	1,7 - 1	1620						
2W2012 ###	12 DC	/	0,08	6,4	2770	225	72	720	67		7
2W2024 ###	24 DC	/	0,09	3,9	2900	225	72	750	67		7
2W2056 ###	Prepared for Gr.2 hydraulic motor					200			/	7	

Contattare EMMEGI Contact EMMEGI

Diagramma rendimento Performance diagram

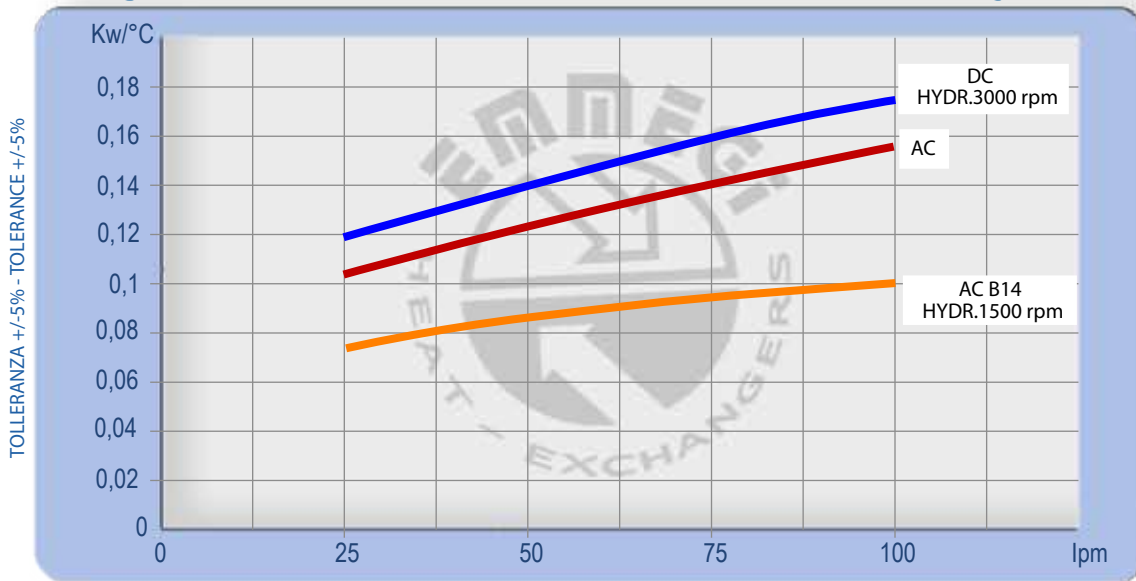

Perdite di carico Pressure drop (ISO VG 32)



Fattore di correzione - F - (perdite di carico) Correction factor - F - (Pressure drop)

cst	10	15	20	30	40	50	60	80	100	200	300
F	0,5	0,65	0,77	1	1,2	1,4	1,6	1,9	2,1	3,3	4,3

Dimensioni Dimensions

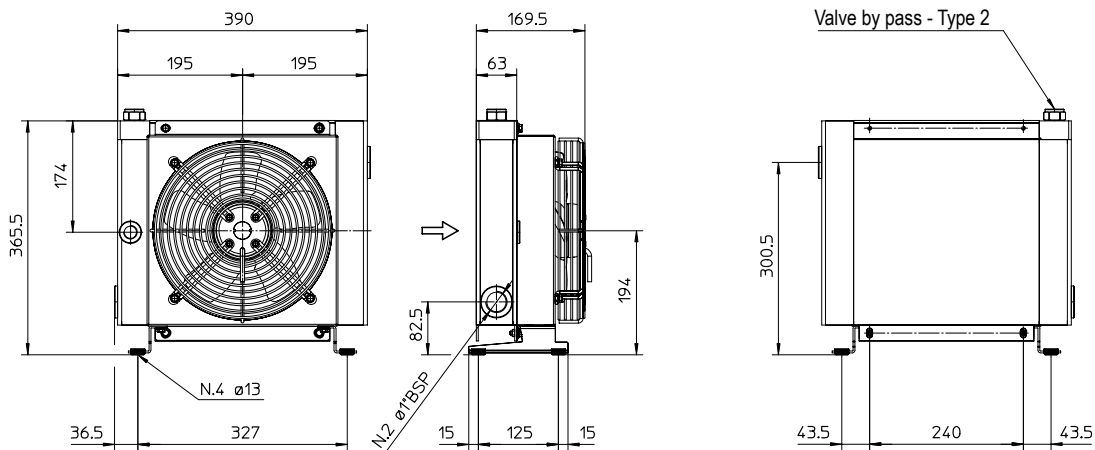

P/N 2W2401###
P/N 2W2403###

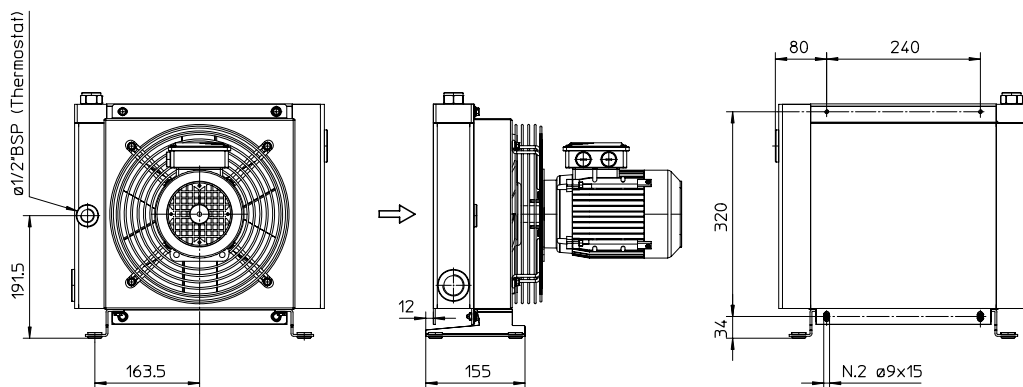

P/N 2W2404###

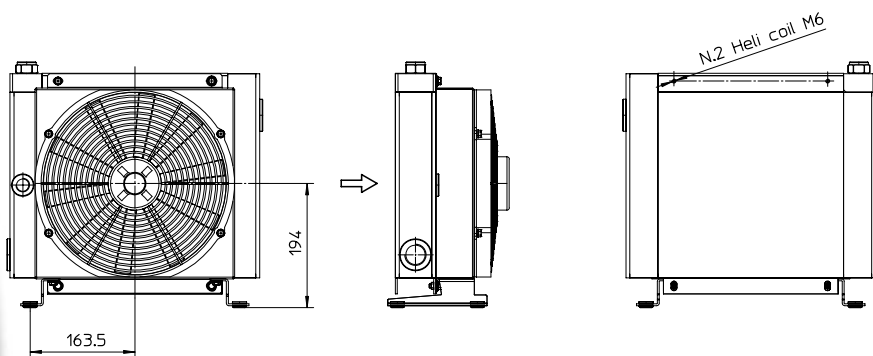

P/N 2W2412###
P/N 2W2424###

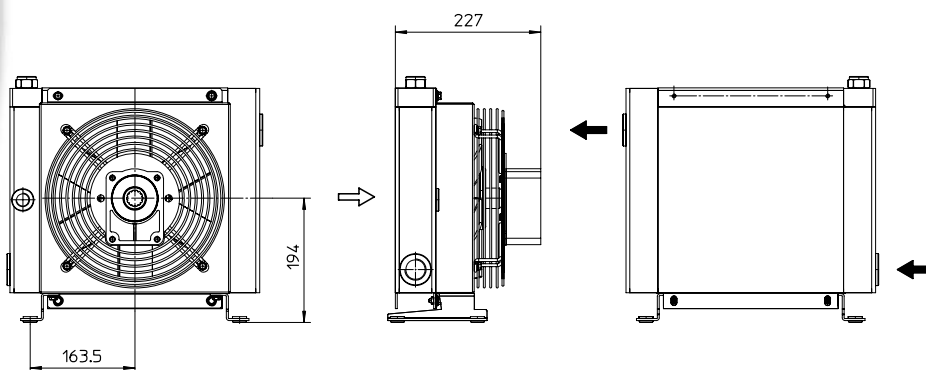

P/N 2W2456###

Le dimensioni di ingombro e le caratteristiche tecniche non sono impegnative
Over-all dimensions and technical characteristic are not binding

MG2024KBV

Dati tecnici Technical Data



P/N	V	Hz	kW(±10%)	A (±10%)	rpm	∅ Fan	dB(A)	(m³/h)	IP	lt	Kg
2W2401 ###	230AC	50/60	0,115/0,150	0,51 - 0,66	2450/2600	250	72	1350	44		11
2W2403 ###	230-400 AC	50	0,105	0,33 - 0,19	2600	250	72	1300	44		11
	230-400 AC	60	0,145	0,39 - 0,23	2900						
2W2404 ###	230-400 AC B14	50	0,25	1,7 - 1	1350	250	64	1000	55	1	16
	265-460 AC B14	60	0,29	1,7 - 1	1620						
2W2412 ###	12 DC	/	0,09	7,5	2710	280	72	950	67		10
2W2424 ###	24 DC	/	0,10	4,3	2765	280	74	1030	67		10
2W2456 ###	Prepared for Gr.2 hydraulic motor					250			/		10

Contattare EMMEGI Contact EMMEGI

Diagramma rendimento Performance diagram

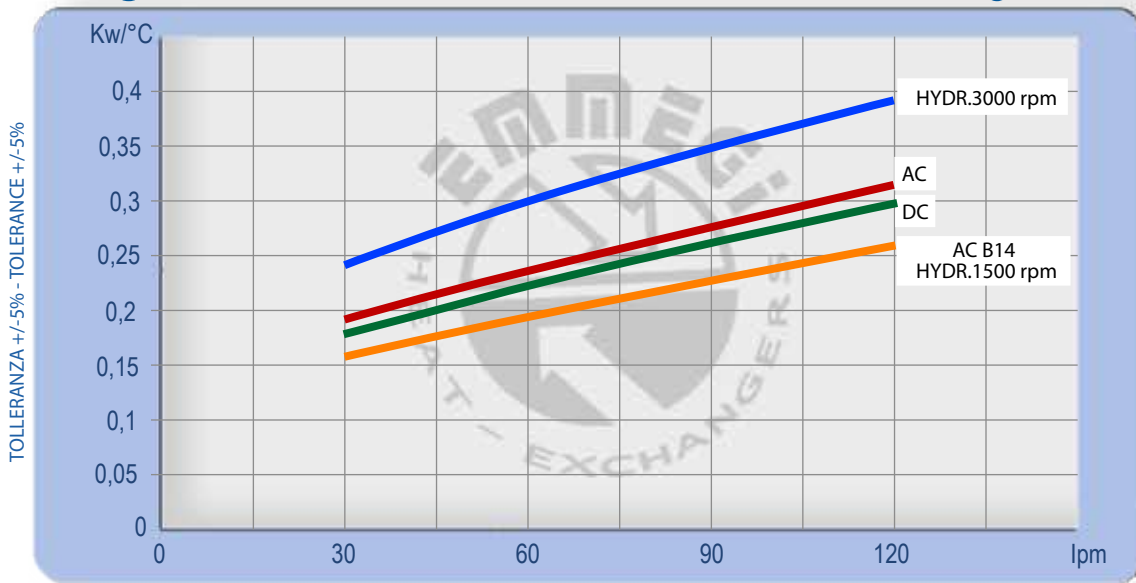

Perdite di carico Pressure drop (ISO VG 32)

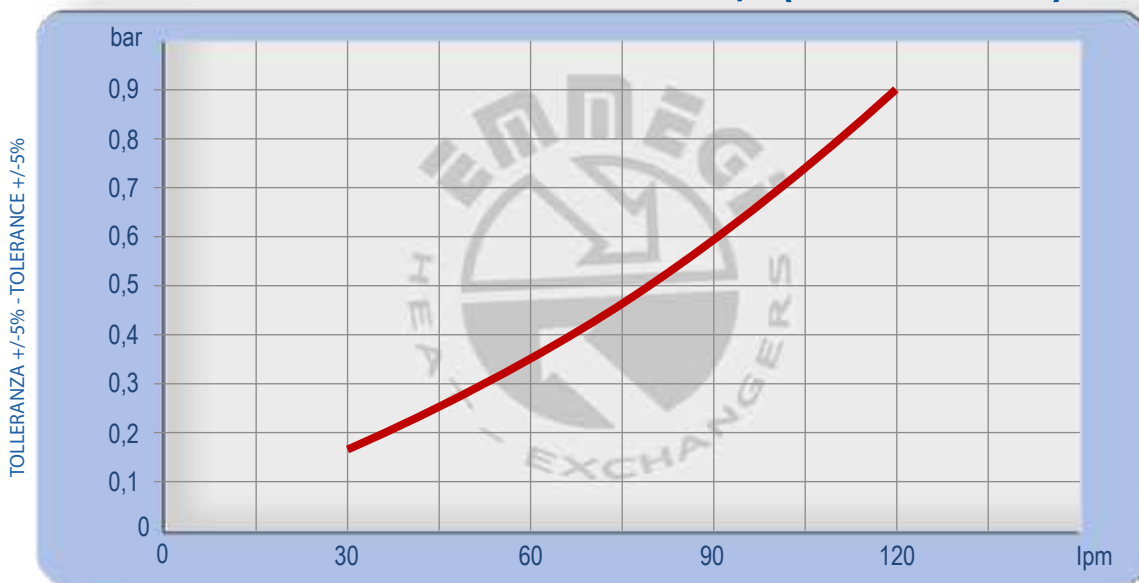

Fattore di correzione - F - (perdite di carico) Correction factor - F - (Pressure drop)

cst	10	15	20	30	40	50	60	80	100	200	300
F	0,5	0,65	0,77	1	1,2	1,4	1,6	1,9	2,1	3,3	4,3

MG2024K1BV

Dimensioni Dimensions

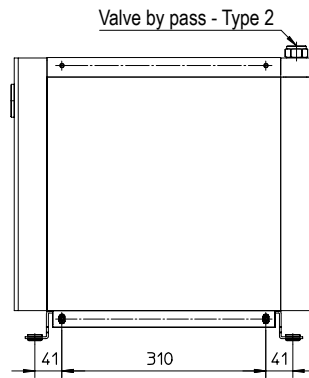
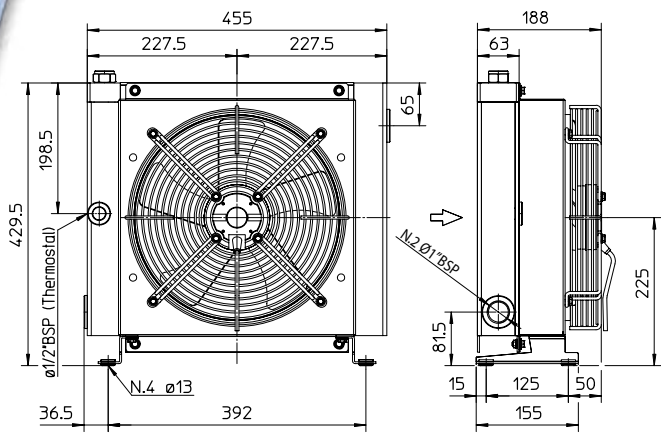

P/N 2W3001###
P/N 2W3003###

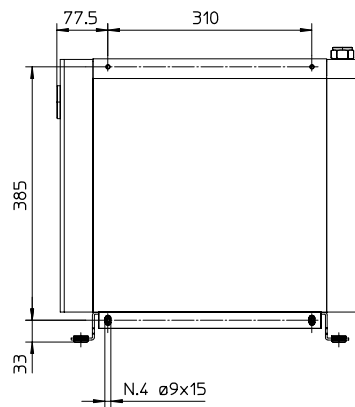
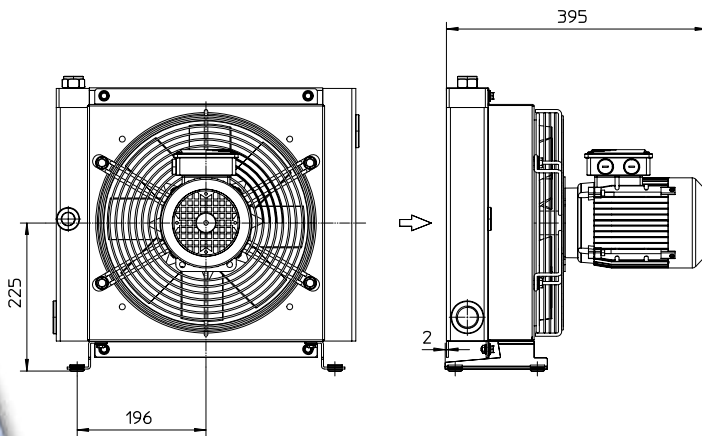

P/N 2W3004###

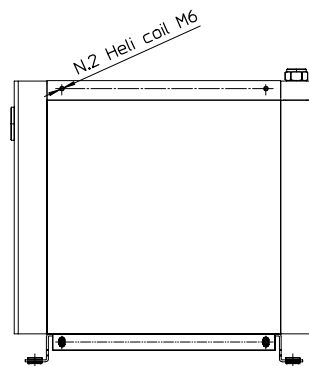
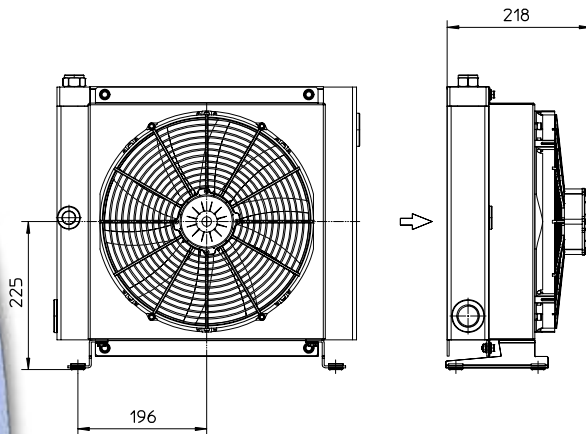

P/N 2W3012###
P/N 2W3024###

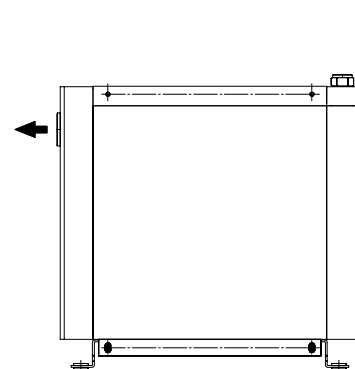
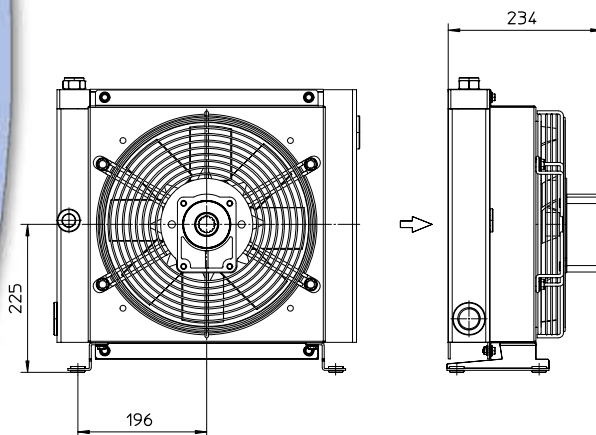

P/N 2W3056###

Le dimensioni di ingombro e le caratteristiche tecniche non sono impegnative
Over-all dimensions and technical characteristic are not binding

MG2030KBV

Dati tecnici Technical Data



P/N	V	Hz	kW(±10%)	A (±10%)	rpm	∅ Fan	dB(A)	(m³/h)	IP	lt	Kg
2W3001 ###	230AC	50/60	0,23 - 0,35	1,1 - 1,55	2700/3000	300	78	2220	44	1,6	15
2W3003 ###	230-400 AC	50	0,21	0,62 - 0,36	2580	300	76	2500	44		15
	230-400 AC	60	0,30	0,84 - 0,48	2750						15
2W3004 ###	230-400 AC B14	50	0,37	2,1 - 1,1	1370	300	70	1850	55		20
	265-460 AC B14	60	0,43	2,1 - 1,1	1650						20
2W3012 ###	12 DC	/	0,16	13,3	2660	305	80	1675	67		14
2W3024 ###	24 DC	/	0,18	7,4	2870	305	83	1880	67	14	
2W3056 ###	Prepared for Gr.2 hydraulic motor					300			/	15	

Contattare EMMEGI Contact EMMEGI

Diagramma rendimento Performance diagram

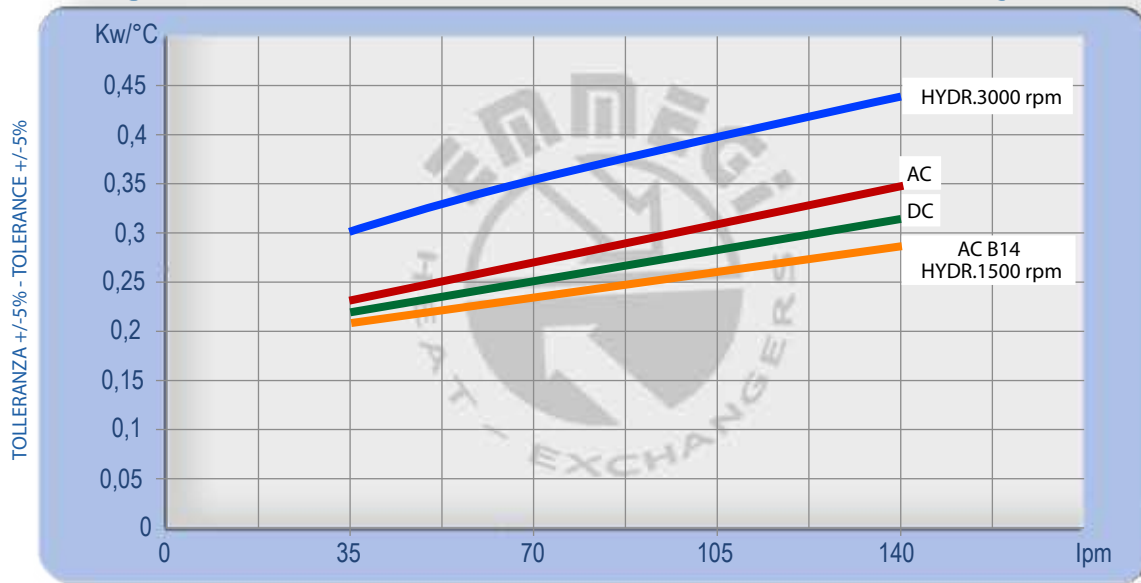

Perdite di carico Pressure drop (ISO VG 32)

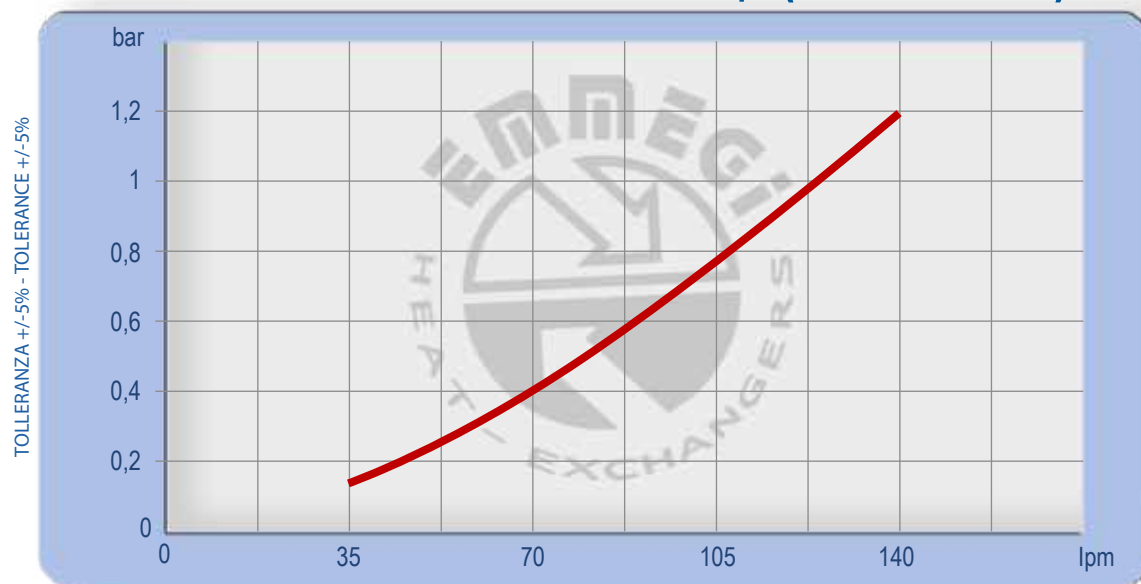

Fattore di correzione - F - (perdite di carico) Correction factor - F - (Pressure drop)

cst	10	15	20	30	40	50	60	80	100	200	300
F	0,5	0,65	0,77	1	1,2	1,4	1,6	1,9	2,1	3,3	4,3

Dimensioni Dimensions

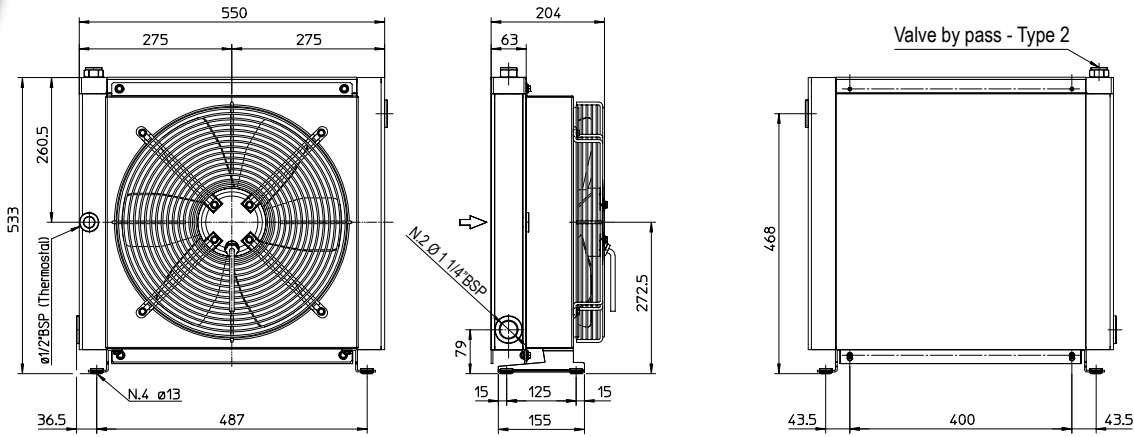

Valve by pass - Type 2



P/N 2W4001###
P/N 2W4003###

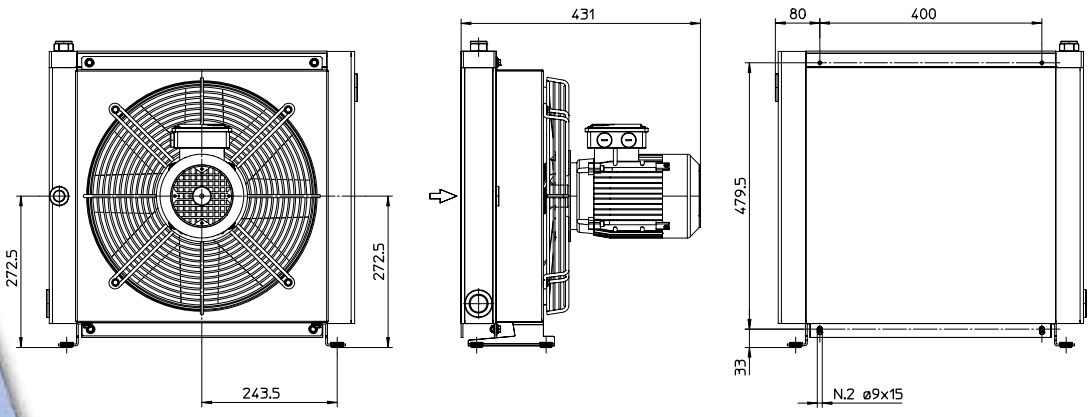

P/N 2W4004###

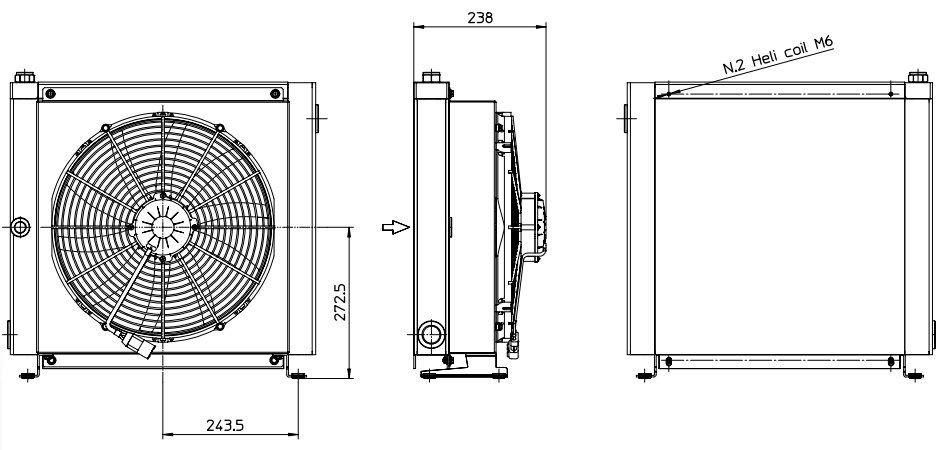

P/N 2W4012###
P/N 2W4024###

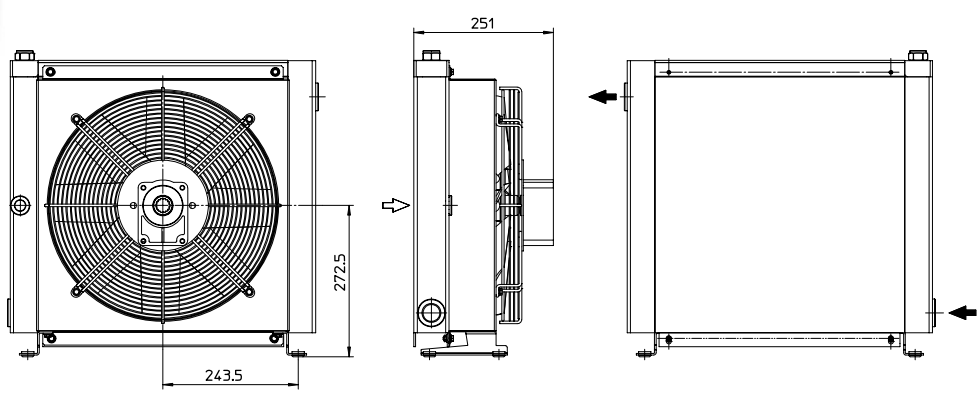

P/N 2W4056###

Le dimensioni di ingombro e le caratteristiche tecniche non sono impegnative
Over-all dimensions and technical characteristic are not binding

MG2040KBV

Dati tecnici Technical Data



P/N	V	Hz	kW(±10%)	A (±10%)	rpm	ø Fan	dB(A)	(m³/h)	IP	lt	Kg
2W4001 ###	230 AC	50	0,16/0,24	0,73 - 1,06	1430/1700	400	71	3200	54	2,7	21
2W4003 ###	230-400 AC	50	0,135	0,76 - 0,44	1450	400	71	3200	54		21
	230-400 AC	60	0,185	0,68 - 0,39	1690						21
2W4004 ###	230-400 AC B14	50	0,55	2,9-1,7	1320	400	77	3740	55		25
	265-460 AC B14	60	0,63	2,9-1,7	1690						25
2W4012 ###	12 DC	/	0,22	19,2	2310	385	76	2770	67		20
2W4024 ###	24 DC	/	0,23	9,3	2380	385	79	2910	67		20
2W4056 ###	Prepared for Gr.2 hydraulic motor					400			/	19	

Contattare EMMEGI Contact EMMEGI

Diagramma rendimento Performance diagram

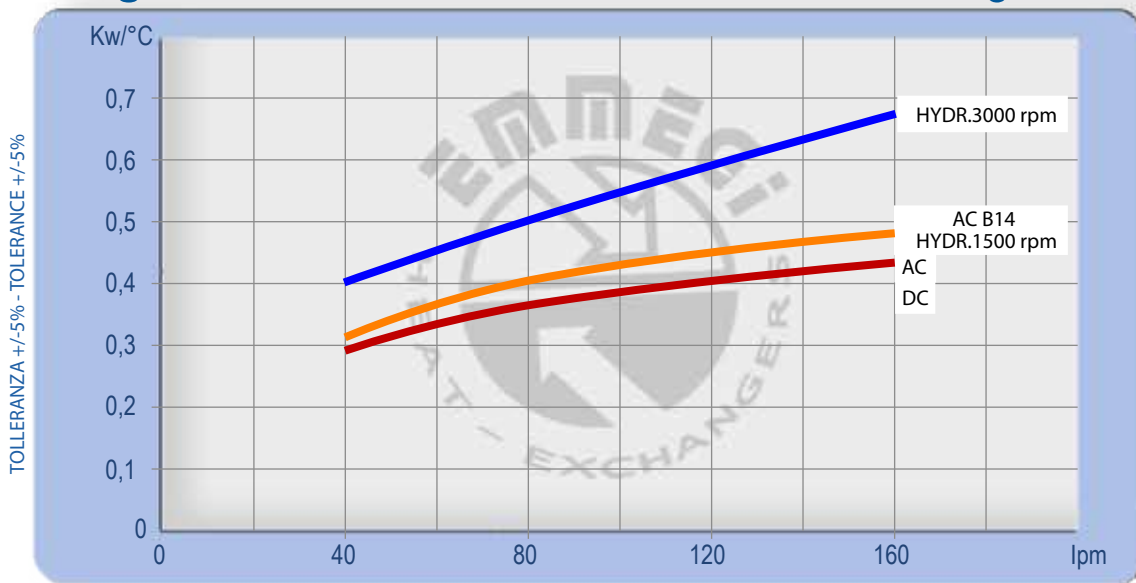

Perdite di carico Pressure drop (ISO VG 32)

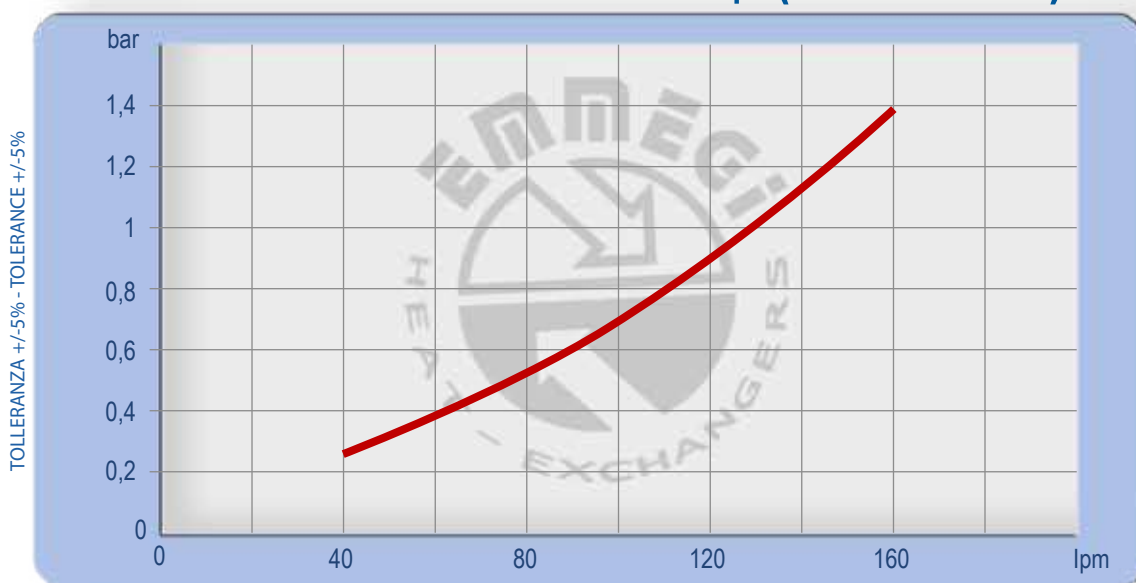

Fattore di correzione - F - (perdite di carico) Correction factor - F - (Pressure drop)

cst	10	15	20	30	40	50	60	80	100	200	300
F	0,5	0,65	0,77	1	1,2	1,4	1,6	1,9	2,1	3,3	4,3

MG2040K1BV

Dimensioni Dimensions

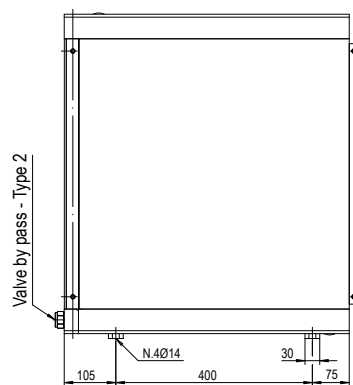
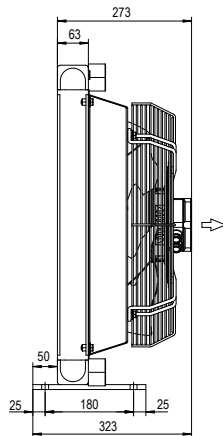
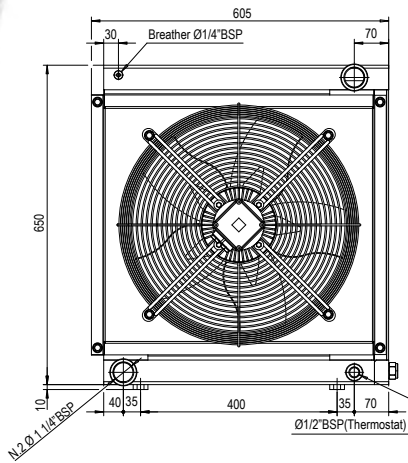

P/N 2W5003###

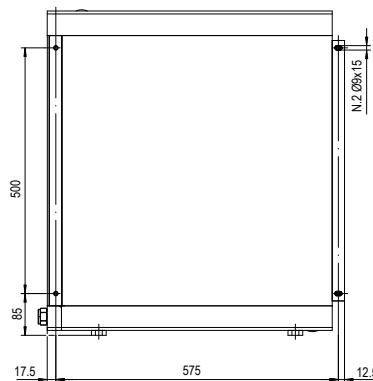
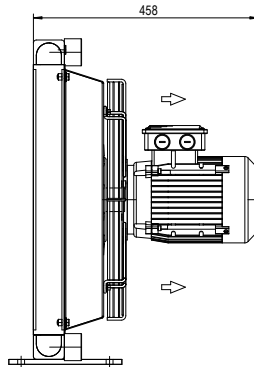
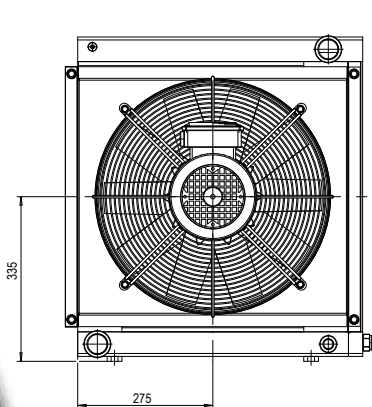

P/N 2W5004###

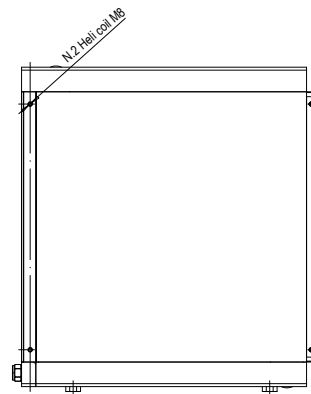
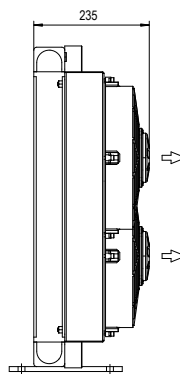
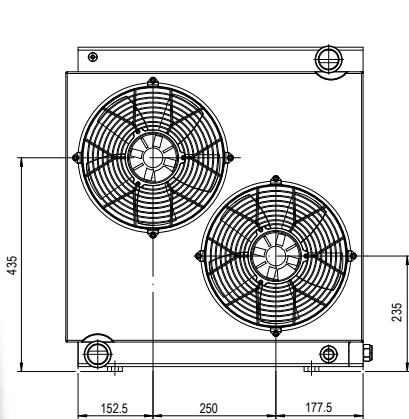

P/N 2W5012###
P/N 2W5024###

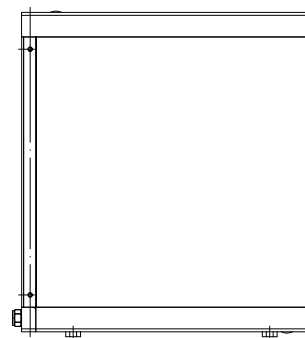
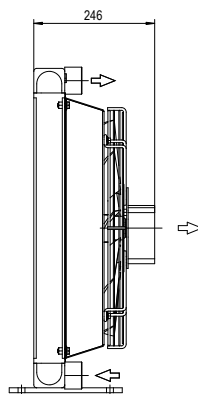
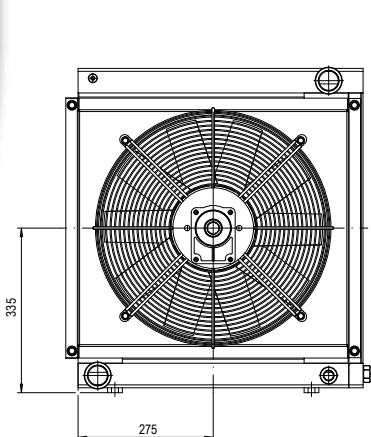

P/N 2W5056###

Le dimensioni di ingombro e le caratteristiche tecniche non sono impegnative
Over-all dimensions and technical characteristic are not binding

Dati tecnici Technical Data



P/N	V	Hz	kW(±10%)	A (±10%)	rpm	∅ Fan	dB(A)	(m³/h)	IP	lt	Kg
2W5003 ###	230-400 AC	50	0,52	1,9 - 1,1	1450	450	76	5000	54	5	27
	230-400 AC	60	0,66	2 - 1,2	1690						
2W5004 ###	230-400 AC B14	50	0,75	3,0 - 1,7	1440	450	79	5200	55	5	30
	265-460 AC B14	60	0,86	3,0 - 1,7	1750						
2W5012 ###	12 DC	/	0,13 (2x)	11,0 (2x)	2340	280	76	1720(2x)	67		24
2W5024 ###	24 DC	/	0,15 (2x)	6,2 (2x)	2600	280	79	1750(2x)	67		24
2W5056 ###	Prepared for Gr.2 hydraulic motor					450			/		23

Per il 12-24V i dati sono riferiti al singolo ventilatore For 12-24V the data refers to each ventilator

Contattare EMMEGI Contact EMMEGI

Diagramma rendimento Performance diagram

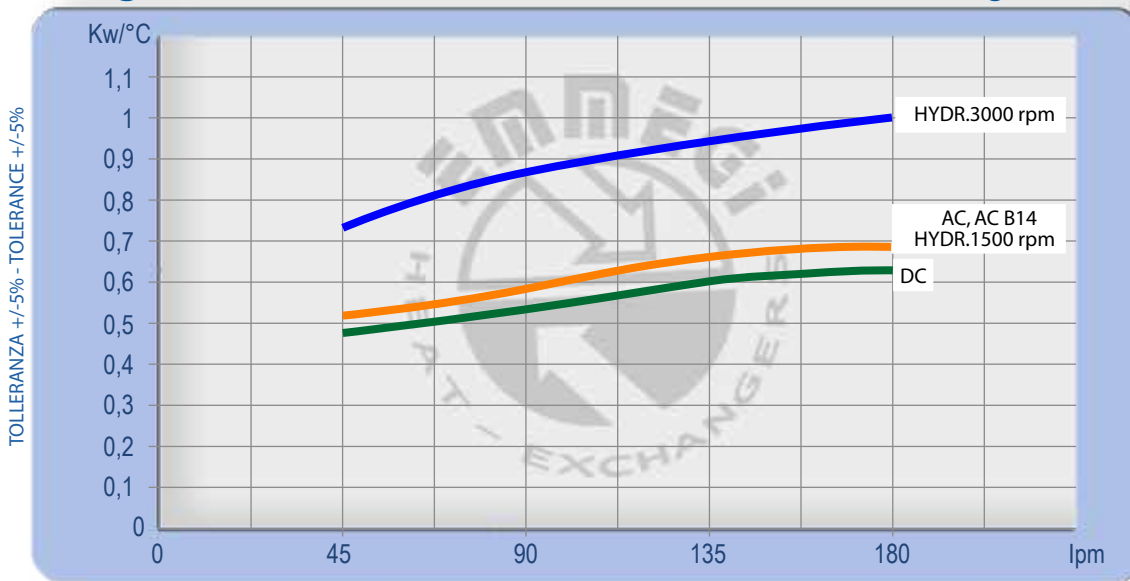

Perdite di carico Pressure drop (ISO VG 32)

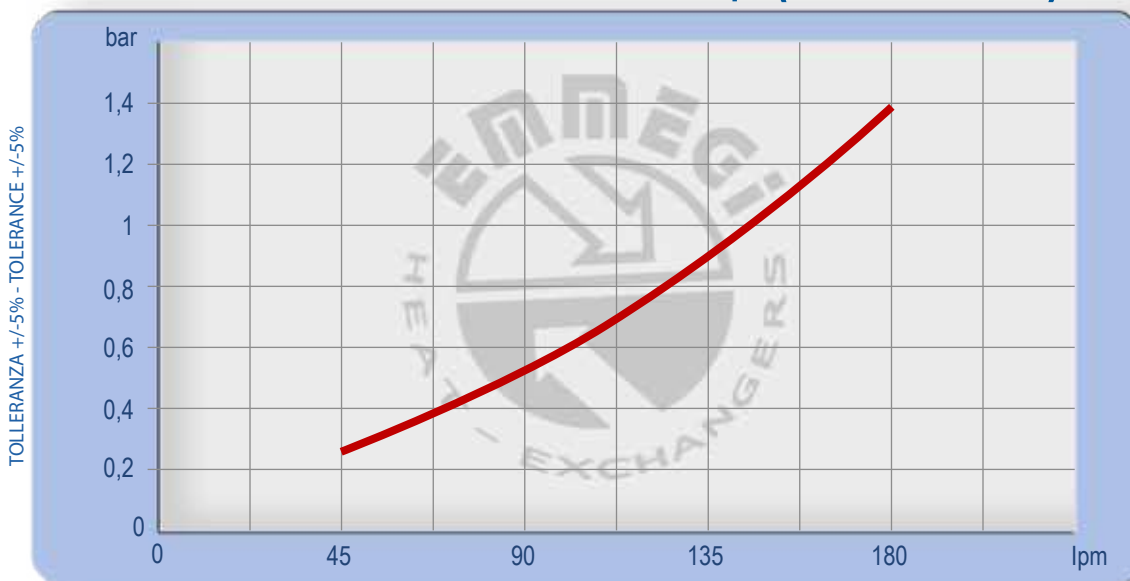

Fattore di correzione - F - (perdite di carico) Correction factor - F - (Pressure drop)

cst	10	15	20	30	40	50	60	80	100	200	300
F	0,5	0,65	0,77	1	1,2	1,4	1,6	1,9	2,1	3,3	4,3

MG2050K1BV

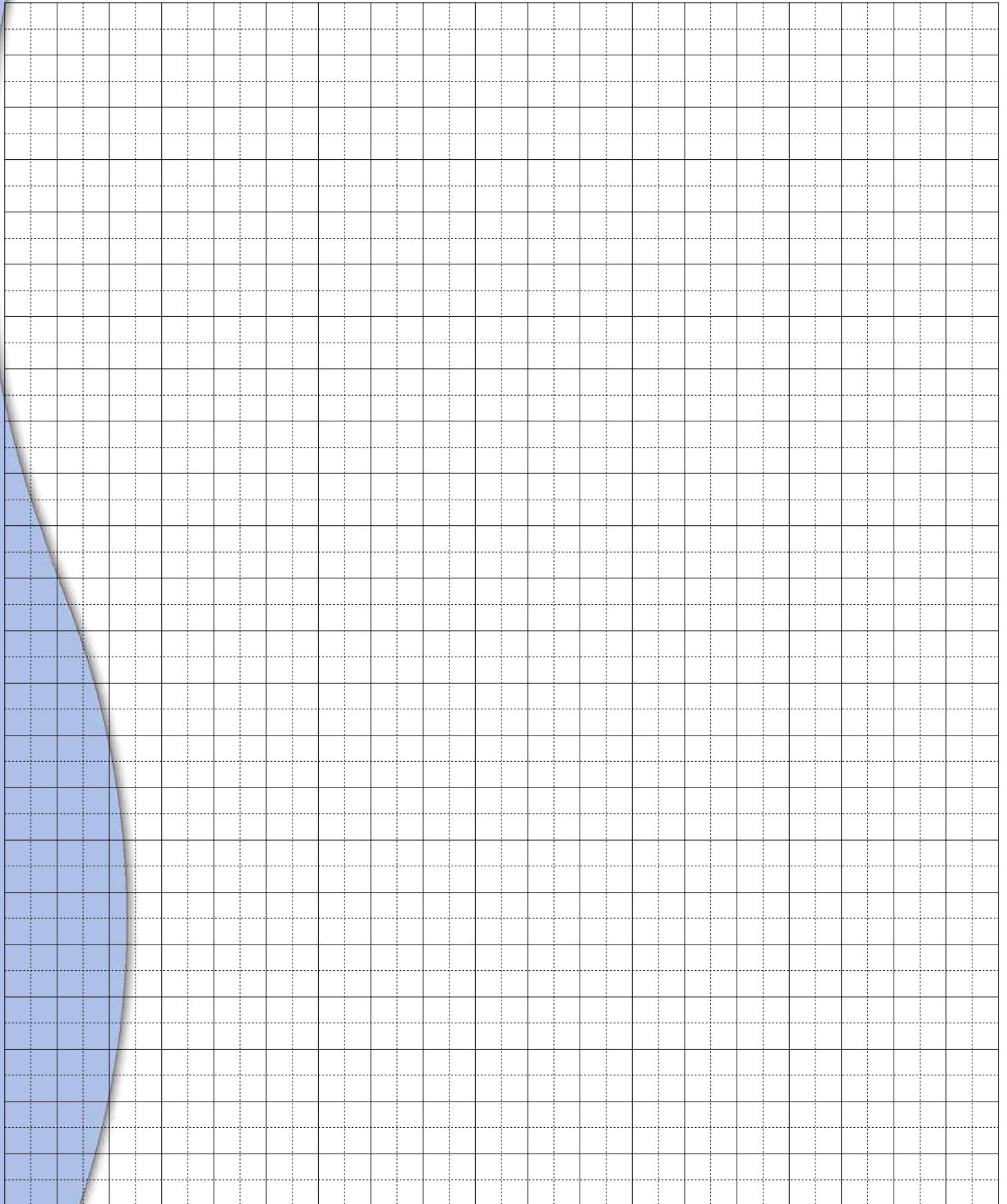

The page contains a large grid of graph paper. The grid is composed of 20 columns and 30 rows of small squares. A blue decorative border is visible on the left side of the page, curving from the top to the bottom. The grid is intended for taking notes or drawing technical diagrams.

Alla ricerca di un continuo miglioramento del prodotto, EMMEGI S.p.A. si riserva il diritto di approntare modifiche ai dati e alle caratteristiche illustrate nel catalogo.

La riproduzione, anche parziale, del presente catalogo è vietata ai termini di legge.

Questo catalogo sostituisce tutti i precedenti.

As EMMEGI S.p.A. are always investigating methods of improving products and introducing new technology, we reserve the right to modify without notice the data features shown in this catalogue.

The reproduction, even partial of this catalogue is forbidden by law.

This catalogue replace all the previous one.

USA

EMMEGI HEAT EXCHANGERS inc.
(Main Office and Manufacturing)
3606 E.Southern Ave. Suite.2
85040 Phoenix AZ
Ph. +1 602 438 7101
Fax +1 602 438 7127
sales@emmegiinc.com
www.emmegiinc.com

SLOVAKIA

EMMEGI HEAT EXCHANGERS s.r.o
Ul. M. Razusa, 1
95514 Topolcany
Ph. +421 385320739
Fax +421 385320742
sro@emmegi-heat-exchangers.com

GERMANY

EMMEGI GmbH
Philipp - Reis - Str.2
D-41516 Grevenbroich-Kapellen
Germany
Ph. +49 - 2182 - 570 180
Fax. +49 - 2182 - 570 1829
vertrieb@emmegi-gmbh.de
www.emmegi-gmbh.de

TURKEY

EMMEGI HEAT EXCHANGERS
Termal Sistemler Sanayi ve Ticaret Ltd. Őti
8229/2 Sok. No: 12 Odin iŐ Merkezi
ÇiĐli - izmir / Turkey
Ph. +90 232 449 4244
Fax. +90 530 392 7636
kudret@emmegi-turkey.com
www.emmegi-turkey.com

EMMEGI U.K.

Unit 19C Coln Park
Andoversford Industrial Estate
Cheltenham
Gloucestershire
GL54 4HJ
Ph. +44 01452 540130
Mob. +44 07825 278394
jquigley@emmegi.co.uk
www.emmegi.co.uk

NORDIC AB.

EMMEGI HEAT EXCHANGERS NORDIC AB.
Viadukgatan 8
SE 341 32 Ljungby
Ph. +46 372 86490
www.emmeginordic.se
info@emmeginordic.se

ITALIA

EMMEGI S.p.A
Via Newton 52 - Zona Industriale
20062 Cassano D' Adda (MI) - Italy
Tel. +39 0363 360236 - Fax +39 0363 360230
info@emmegi-heat-exchangers.com
www.emmegi-heat-exchangers.com



LubeTeam Hydraulic S.r.l.

Administration and Headquarter:

Via Tufara Scautieri, 6

83018 - San Martino Valle Caudina (AV)

Office and Warehouse:

S.S. 7 Appia, Km. 237,00

82011 - Airola BN

ITALY

Tel. +39 0823 950 994

Fax +39 0823 412 546

www.lubeteam.it info@lubeteam.it

Italian VAT / C.F. e P.IVA: 01251720627

Follow us



This document is the property of LubeTeam Hydraulic S.r.l. All data reported here are for the exclusive use of the Receiver. Reproduction is not authorized without writing permission, in all or in part of the content of this document, in accordance to Law 633 art. 171, dated April 22, 1941.

Il presente documento è di proprietà della LubeTeam Hydraulic S.r.l. I dati riportati sono per esclusivo del destinatario. La riproduzione, di tutto o in parte, non è autorizzata senza permesso scritto secondo l'art. 171 della L. 633 del 22 Aprile 1941.