



MP Filter
LMP 430-431
Series



 HYDRAULIC
COMPONENTS
& FLUID CONTAMINATION
CONTROL

LMP 430-431 series

Maximum working pressure up to 5 MPa (50 bar) - Flow rate up to 780 l/min



Description

Low & Medium Pressure filters

Maximum working pressure up to 5 MPa (50 bar)
Flow rate up to 780 l/min

LMP431-431 is a range of low pressure filter with large filtration surface mainly suitable for lubrication, off-line filtration of the reservoirs and filtration equipment.

They are directly connected to the lines of the system through the hydraulic fittings.

Available features:

- Female threaded connections up to 2" and flanged connections up to 2 1/2", for a maximum flow rate of 780 l/min
- In line or 90° connections, to meet any type of application
- Base-mounting design also available, for ease of the replacement of the filter element
- Fine filtration rating, to get a good cleanliness level into the system
- Water removal elements, to remove the free water from the hydraulic fluid. For further information, see the Contamination Management document and the dedicate leaflet.
- Bypass valve, to relieve excessive pressure drop across the filter media
- Vent ports, to avoid air trapped into the filter going into the system
- Drain ports, to remove the fluid from the housing prior the maintenance work
- Visual, electrical and electronic differential clogging indicators

Common applications:

- Off-line filtration of reservoirs
- Filtration systems

Technical data

Filter housing materials

- Head: Anodized Aluminium
- Housing: Anodized Aluminium
- Bypass valve: Steel

Pressure LMP 430-431

- Test pressure: 7.5 MPa (75 bar)
- Min. Burst pressure: 15 MPa (150 bar)
- Pulse pressure fatigue test: 1 000 000 cycles with pressure from 0 to 5 MPa (50 bar)

Bypass valve

- Opening pressure 0.35 MPa (3.5 bar) ±10%
- Other opening pressures on request.

Filter element features

Filter LMP 430-431		Filter element CU	
Δp Element type			
Element media	Construction	Δp Series	Δp
A - Microfiber	Standard	N	20 bar
M - Wire mesh	Standard	N	20 bar
P - Paper	Standard	N	20 bar
<i>Please see ordering code tables to check element Δp series availability based on filter features.</i>			
Flow direction through the filter element: From OUT to IN			

Seals

- Standard NBR series A
- Optional FPM series V

Connections

LMP 400 - 430: In-line Inlet/Outlet
 LMP 401 - 431: 90° Inlet/Outlet

Temperature

From -25 °C to +110 °C

Note

LMP 400 filters are provided for vertical mounting

Weights [kg] and volumes [dm³]

Filter series	Length	Weights [kg]		Length	Volumes [dm ³]	
		5	6		5	6
LMP 430 - 431		11.90	14.40		9.50	13.50

Flow rates [l/min]

Filter series	Length	Filter element design - N Series							
		A03	A06	A10	A16	A25	M25 M60 M90	P10	P25
LMP 430	5	459	501	610	660	717	781	700	721
	6	504	575	676	689	728	783	708	727
LMP 431	5	423	456	544	582	626	674	613	629
	6	459	516	594	604	634	676	619	633

Maximum flow rate for a complete low and medium pressure filter with a pressure drop $\Delta p = 0.7$ bar.

The reference fluid has a kinematic viscosity of 30 mm²/s (cSt) and a density of 0.86 kg/dm³.

For different pressure drop or fluid viscosity we recommend to use our selection software available on www.mpfiltri.com.

You can also calculate the right size using the formulas present on the FILTER SIZING paragraph at the beginning of the full catalogue or at the beginning of the filter family brochure. Please, contact our Sales Department for further additional information.

LMP 430-431: execution P02

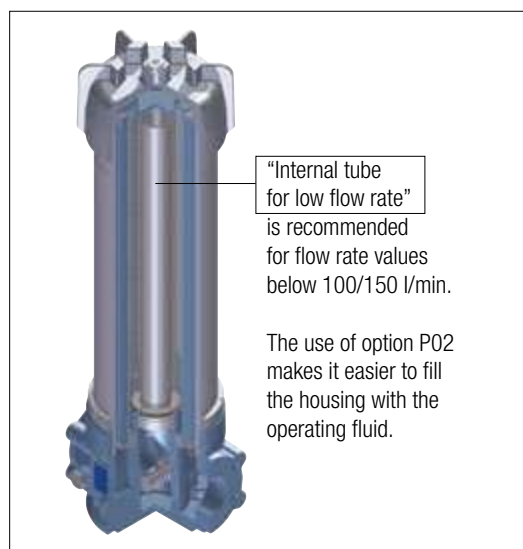

Hydraulic symbols

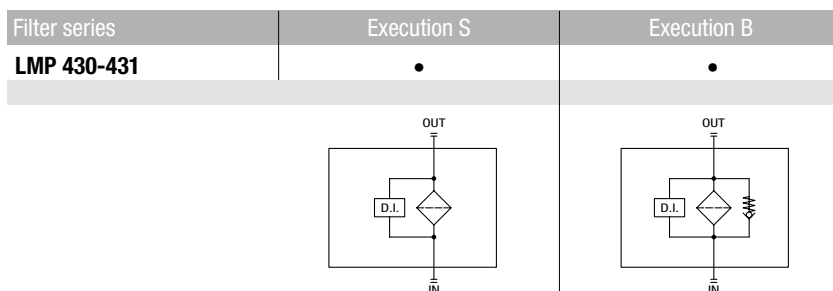

Pressure drop

Filter housings Δp pressure drop

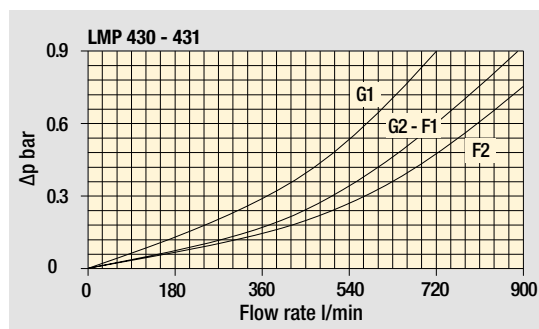

Bypass valve pressure drop

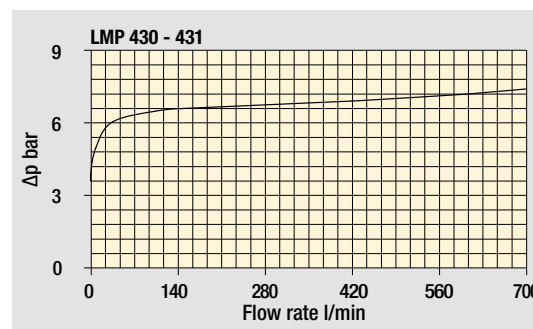

The curves are plotted using mineral oil with density of 0.86 kg/dm³ in compliance with ISO 3968. Δp varies proportionally with density.

LMP 430-431

Designation & Ordering code

COMPLETE FILTER

Series and size		Configuration example: LMP431 5 B A G1 A10 N P01									
LMP430 LMP431											
Length											
5 6											
Bypass valve											
S Without bypass		B With bypass 3.5 bar									
Seals and treatments		Filtration rating									
		Axx	Mxx	Pxx							
A NBR		•	•	•							
V FPM		•	•	•							
W NBR with surface-treatment on filter element's tube		•	•	-							
Connections											
G1 G 1 1/2"		F1 2" SAE 3000 psi/M									
G2 G 2"		F2 2 1/2" SAE 3000 psi/M									
G3 1 1/2" NPT		F3 2" SAE 3000 psi/UNC									
G4 2" NPT		F4 2 1/2" SAE 3000 psi/UNC									
G5 SAE 24 - 1 7/8" - 12 UN											
G6 SAE 32 - 2 1/2" - 12 UN											
Filtration rating (filter media)											
A03 Inorganic microfiber 3 µm		M25 Wire mesh 25 µm									
A06 Inorganic microfiber 6 µm		M60 Wire mesh 60 µm									
A10 Inorganic microfiber 10 µm		M90 Wire mesh 90 µm									
A16 Inorganic microfiber 16 µm		P10 Resin impregnated paper 10 µm									
A25 Inorganic microfiber 25 µm		P25 Resin impregnated paper 25 µm									
WA025 Water absorber inorganic microfiber 25 µm											
Element Δp		Execution									
N 20 bar		P01 MP Filtri standard									
		P02 With internal tube for low flow rate									
		Pxx Customized									

FILTER ELEMENT

Element series and size		Configuration example: CU400 5 A10 A N P01									
CU400											
Element length											
5 6											
Filtration rating (filter media)											
A03 Inorganic microfiber 3 µm		M25 Wire mesh 25 µm									
A06 Inorganic microfiber 6 µm		M60 Wire mesh 60 µm									
A10 Inorganic microfiber 10 µm		M90 Wire mesh 90 µm									
A16 Inorganic microfiber 16 µm		P10 Resin impregnated paper 10 µm									
A25 Inorganic microfiber 25 µm		P25 Resin impregnated paper 25 µm									
WA025 Water absorber inorganic microfiber 25 µm											
Seals		Filtration rating									
		Axx	Mxx	Pxx							
A NBR		•	•	•							
V FPM		•	•	•							
W NBR with surface-treatment on tube		•	•	-							
Element Δp		Execution									
N 20 bar		P01 MP Filtri standard									
		Pxx Customized									

CLOGGING INDICATORS

See page 720

DEA Electrical differential pressure indicator	DLE Electrical / visual differential pressure indicator
DEM Electrical differential pressure indicator	DTA Electronic differential pressure indicator
DEU Electrical differential pressure indicator	DVA Visual differential pressure indicator
DLA Electrical / visual differential pressure indicator	DVM Visual differential pressure indicator

PLUGS

See page 741

T2 Plug

LMP 430-431

Dimensions

LMP430		
Filter length	H [mm]	H2 [mm]
5	828	660
6	1158	690

Connections	R
G1-G2	M12
G3-G4-G5-G6	1/2" UNC
F1-F2	M12
F3-F4	1/2" UNC

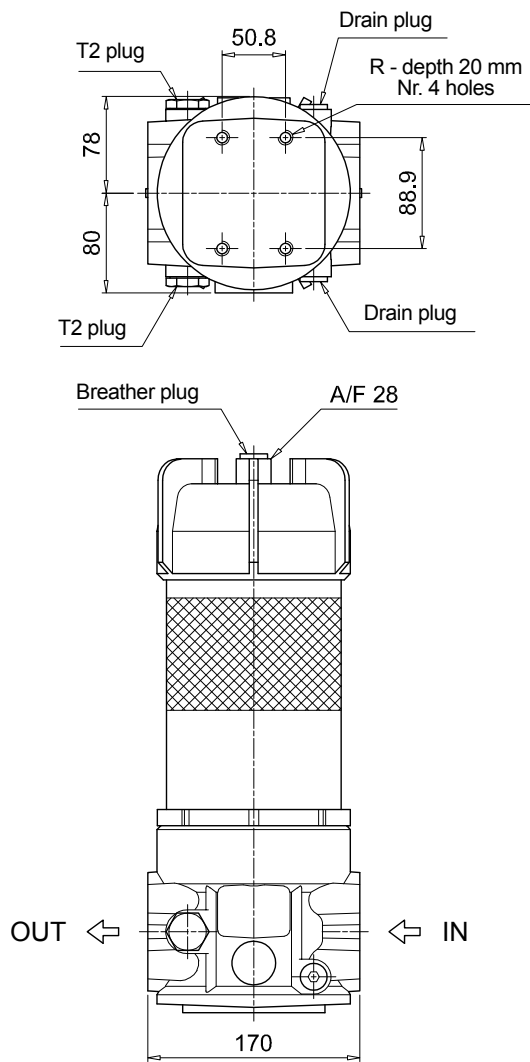

T2 plug =
connection for diff. pressure indicator

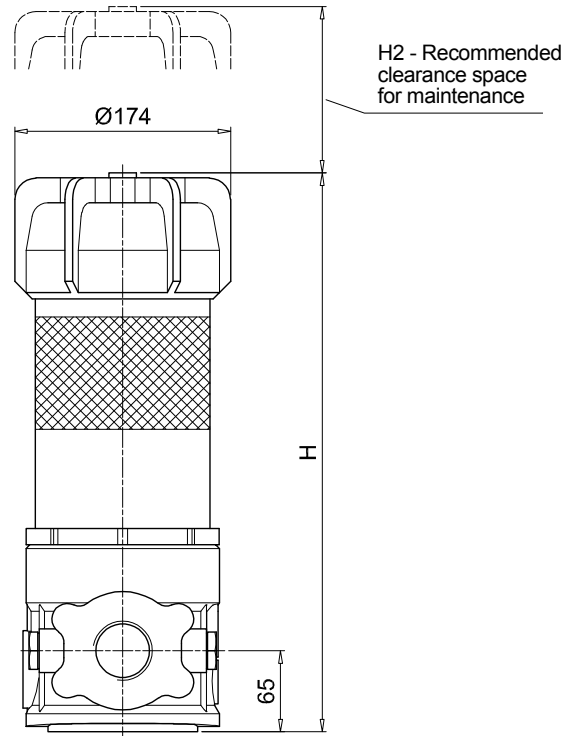

LMP 430-431

Dimensions

LMP431

Filter length	H [mm]	H2 [mm]
5	828	660
6	1158	690

Connections	R
G1-G2	M12
G3-G4-G5-G6	1/2" UNC
F1-F2	M12
F3-F4	1/2" UNC

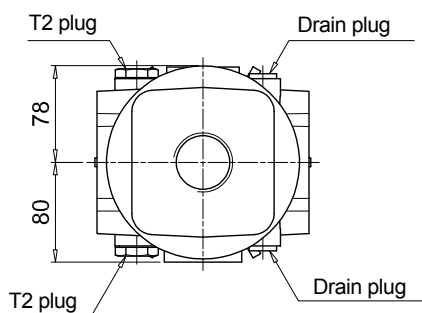

T2 plug =
connection for diff. pressure indicator

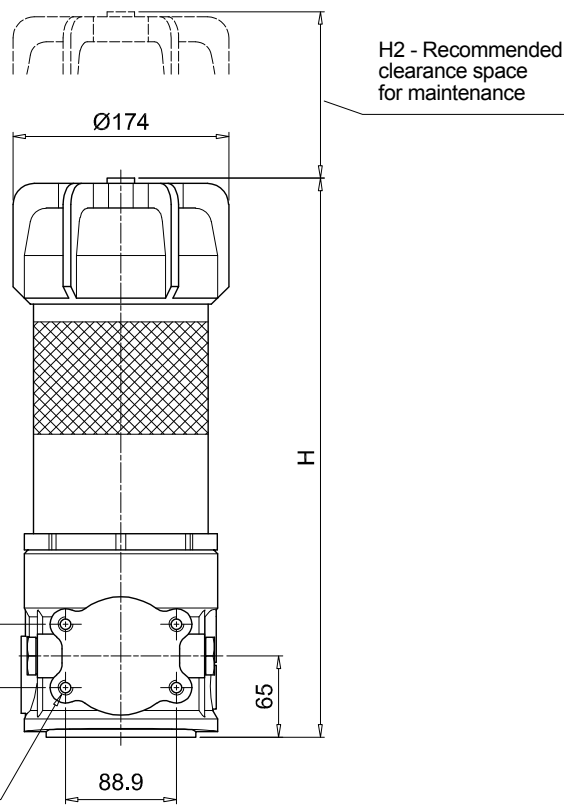
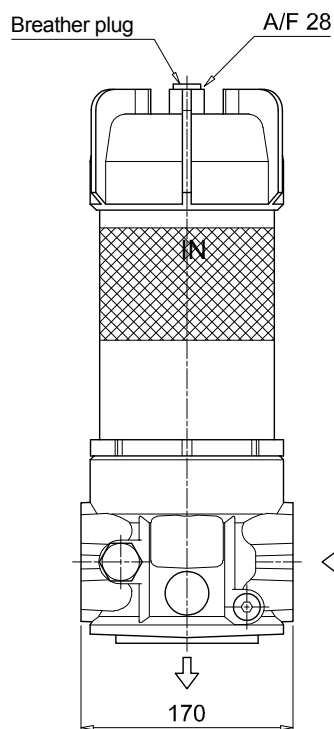

LMP 430 - 431

length 5 - 6

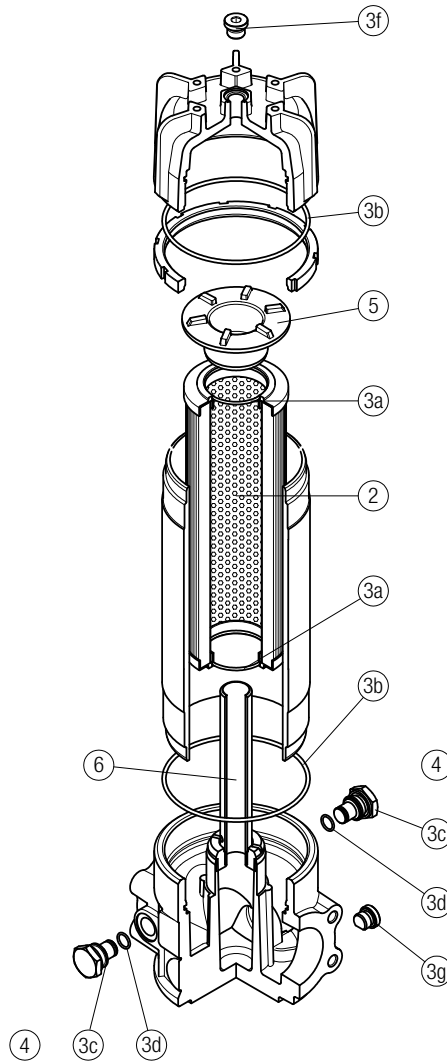

Item:	Q.ty: 1 pc.		Q.ty: 1 pc.		Q.ty: 2 pcs.		Q.ty: 2 pcs.		Q.ty: 1 pc.	
Filter series	Filter element	Seal Kit code number NBR	FPM	Indicator connection plug NBR	FPM	Housing spigot no bypass	with bypass	Internal tube for low flow rate, execution P02		
LMP 430-431 length 5-6	See order table	02050393	02050394	T2H	T2V	01044108	02001414	Length 5: 02025041	Length 6: 02025042	

LubeTeam Hydraulic S.r.l.

Administration and Headquarter:

Via Tufara Scautieri, 6

83018 - San Martino Valle Caudina (AV)

Office and Warehouse:

S.S. 7 Appia, Km. 237,00

82011 - Airola BN

ITALY

Tel. +39 0823 950 994

Fax +39 0823 412 546

www.lubeteam.it info@lubeteam.it

Italian VAT / C.F. e P.IVA: 01251720627

Follow us



This document is the property of LubeTeam Hydraulic S.r.l. All data reported here are for the exclusive use of the Receiver. Reproduction is not authorized without writing permission, in all or in part of the content of this document, in accordance to Law 633 art. 171, dated April 22, 1941.

Il presente documento è di proprietà della LubeTeam Hydraulic S.r.l. I dati riportati sono per esclusivo del destinatario. La riproduzione, di tutto o in parte, non è autorizzata senza permesso scritto secondo l'art. 171 della L. 633 del 22 Aprile 1941.