



MP Filter
LMP 952-953-954
Series



 HYDRAULIC
COMPONENTS
& FLUID CONTAMINATION
CONTROL

LMP 952-953-954 series

Maximum working pressure up to 2.5 MPa (25 bar) - Flow rate up to 4500 l/min



LMP 952-953-954 GENERAL INFORMATION

Description

Technical data

Low & Medium Pressure filters

Maximum working pressure up to 2.5 MPa (25 bar)
Flow rate up to 4500 l/min

LMP952, LMP953 and LMP954 are ranges of low pressure filter with large filtration surface mainly suitable for lubrication, off-line filtration of the reservoirs and filtration equipment.

Multiple LMP950 filters are connected to a manifold to reduce the pressure drop caused by the filter media and to increase the life time of the filter element.

They are directly connected to the lines of the system through the hydraulic fittings.

Available features:

- 4" flanged connections, for a maximum flow rate of 4500 l/min
- Base-mounting design, for ease of the replacement of the filter element
- Fine filtration rating, to get a good cleanliness level into the system
- Water removal elements, to remove the free water from the hydraulic fluid. For further information, see the Contamination Management document and the dedicate leaflet.
- Bypass valve, to relieve excessive pressure drop across the filter media
- Vent ports, to avoid air trapped into the filter going into the system
- Drain ports, to remove the fluid from the housing prior the maintenance work
- Visual, electrical and electronic differential clogging indicators

Common applications:

- Off-line filtration of reservoirs
- Filtration systems

Filter housing materials

- Head: Anodized Aluminium
- Housing: Anodized Aluminium
- Manifolds: Welded - Phosphatized Steel
- Bypass valve: Anodized Aluminium

Pressure

- Test pressure: 3.5 MPa (35 bar)
- Min. Burst pressure: 7.5 MPa (75 bar)
- Pulse pressure fatigue test: 1 000 000 cycles with pressure from 0 to 2.5 MPa (25 bar)

Bypass valve

- Opening pressure 0.35 MPa (3.5 bar) $\pm 10\%$
- Other opening pressures on request.

Number of filter elements

- LMP 952: 2 filter elements CU950-3
- LMP 953: 3 filter elements CU950-3
- LMP 954: 4 filter elements CU950-3

Filter element features

Filter	Filter element		
LMP 951-953-954	CU		
Δp Element type			
Element media	Construction	Δp Series	Δp
A - Microfiber	Standard	N	20 bar
M - Wire mesh	Standard	N	20 bar
P - Paper	Standard	N	20 bar
<i>Please see ordering code tables to check element Δp series availability based on filter features.</i>			
Flow direction through the filter element:			
From OUT to IN			

Seals

- Standard NBR series A
- Optional FPM series V

Temperature

From -25 °C to +110 °C

Connections

LMP 952-953-954:
In-line Inlet/Outlet

Note

LMP 952 - 953 - 954 filters are provided for vertical mounting

Weights [kg] and volumes [dm³]

Filter series	Weights [kg]		Volumes [dm ³]	
	Length	3	Length	3
LMP 952		96		66
LMP 953		138		99
LMP 954		192		132

Flow rates [l/min]

Filter series	Length	Filter element design - N Series					
		A03	A06	A10	A16	A25	M25 M60 M90
LMP 952	3	2172	2294	2766	3106	3256	3998
LMP 953	3	2842	2964	3403	3696	3820	4395
LMP 954	3	3259	3372	3770	4026	4133	4618

Maximum flow rate for a complete low and medium pressure filter with a pressure drop $\Delta p = 0.7$ bar.

The reference fluid has a kinematic viscosity of 30 mm²/s (cSt) and a density of 0.86 kg/dm³.

For different pressure drop or fluid viscosity we recommend to use our selection software available on www.mpfiltri.com.

You can also calculate the right size using the formulas present on the FILTER SIZING paragraph at the beginning of the full catalogue or at the beginning of the filter family brochure. Please, contact our Sales Department for further additional information.

Hydraulic symbols

Filter series	Execution S - Execution B	Execution S - Execution B	Execution S - Execution B
LMP 952	•	-	-
LMP 953	-	•	-
LMP 954	-	-	•

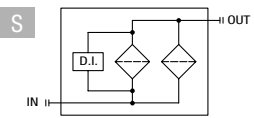
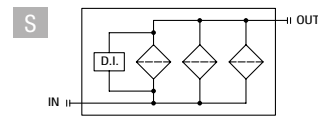
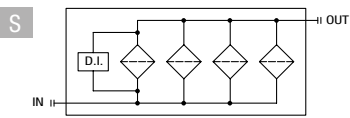
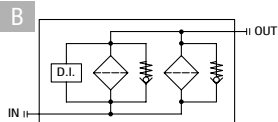
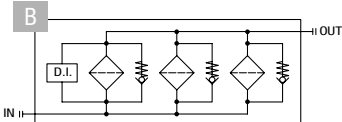
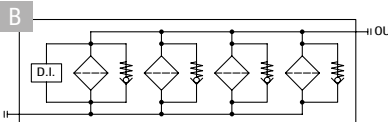
S		S		S	
B		B		B	

LMP 952-953-954 GENERAL INFORMATION

Pressure drop

Filter housings Δp pressure drop

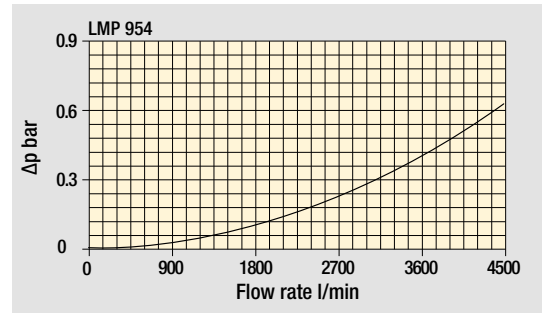
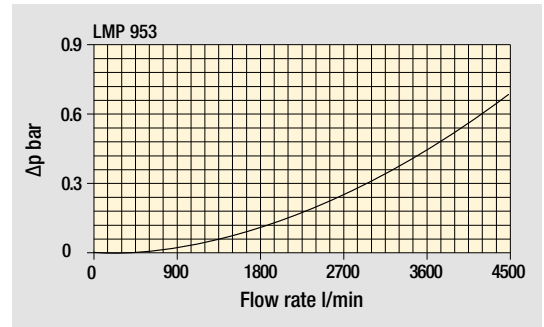
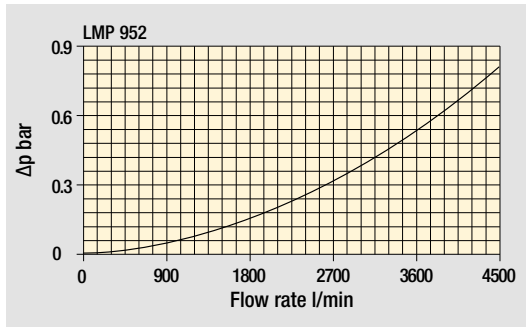

Pressure drop of filter complete with cartridge, oil viscosity 30 mm²/s (cSt)

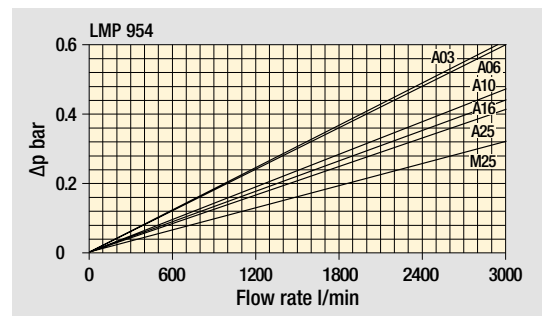
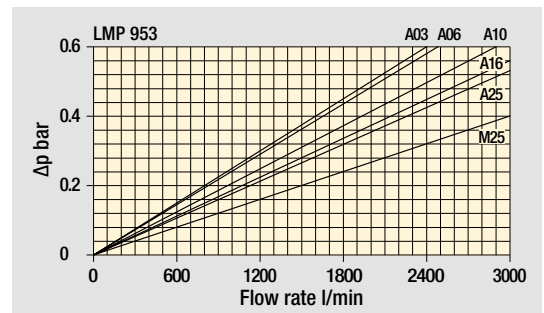
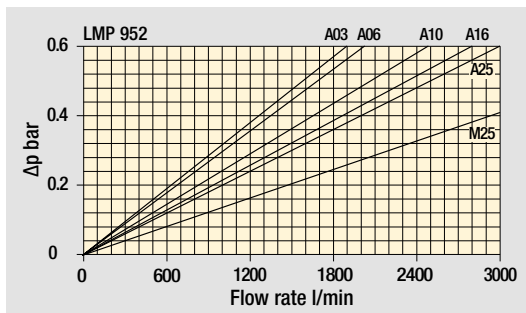

Bypass valve pressure drop

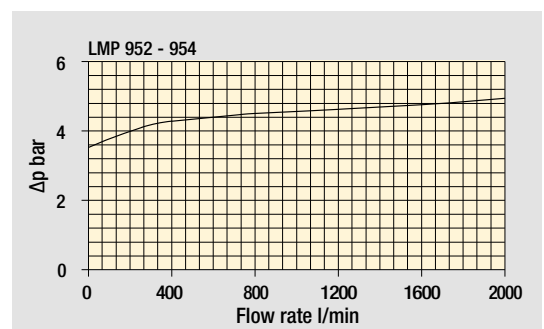

The curves are plotted using mineral oil with density of 0.86 kg/dm³ in compliance with ISO 3968. Δp varies proportionally with density.

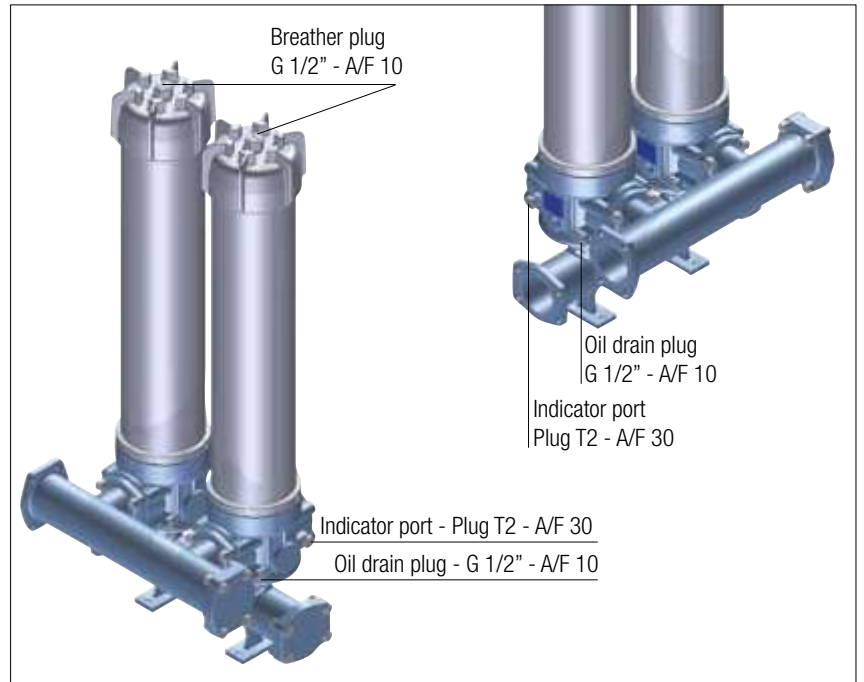
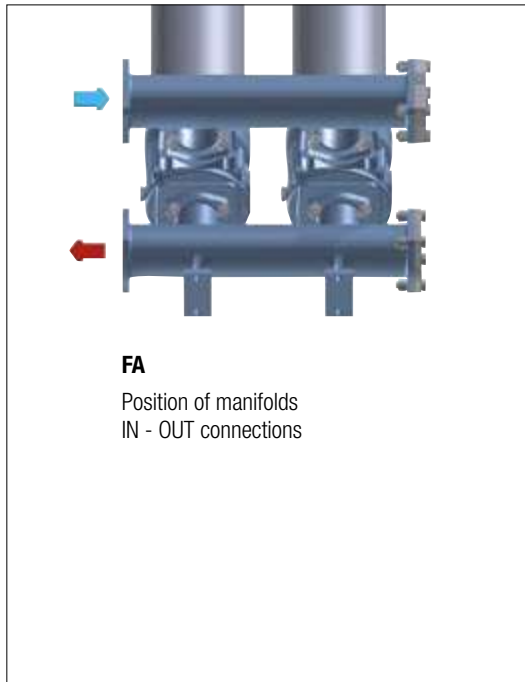

Execution P02

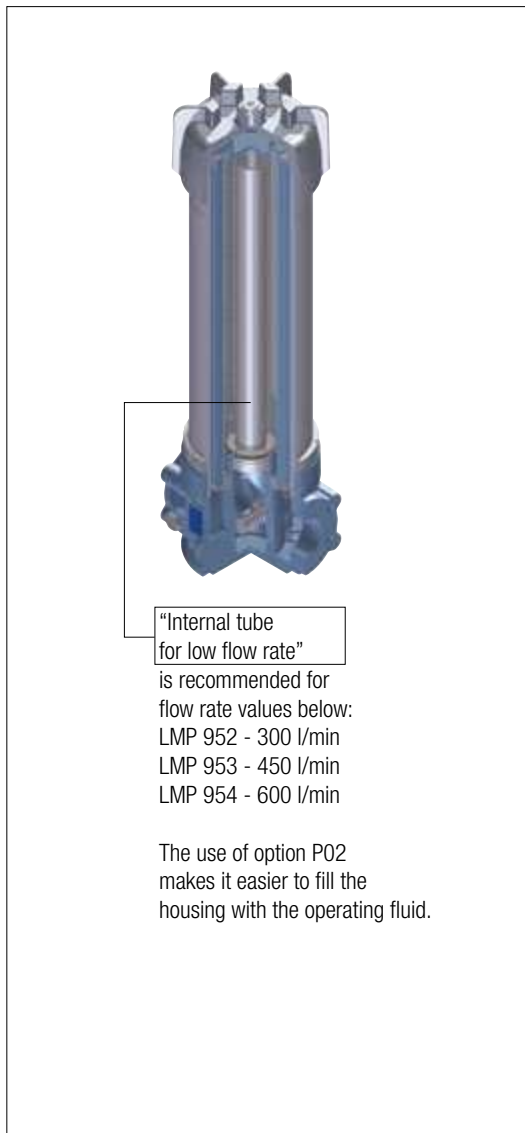

CMV4 & CUV4 Flange options

Code	Thread	Materials
CMV4	G 1 1/4"	1 - 4" SAE flange 2 - O-R 4437 (FPM) for flange 3 - Plug G 1-1/4" 4 - O-R 3168 for plug (FPM) 5 - No. 4 Hex bolt screws UNI-EN 24017 M16 x 65-10.9 6 - No. 4 Spring washers UNI 1751-B 16 7 - No. 4 Nuts UNI 5587 - M16
CUV4	SAE 20	1 - 4" SAE flange 2 - O-R 4437 (FPM) for flange 3 - Plug SAE 20 1 5/8" - 12 UN 4 - 1147 O-R for plug (FPM) 5 - No. 4 Hex bolt screws 5/8" UNC x 2 1/2" 6 - No. 4 Spring washers UNI 1751-B 16 7 - No. 4 Nuts 5/8" UNC

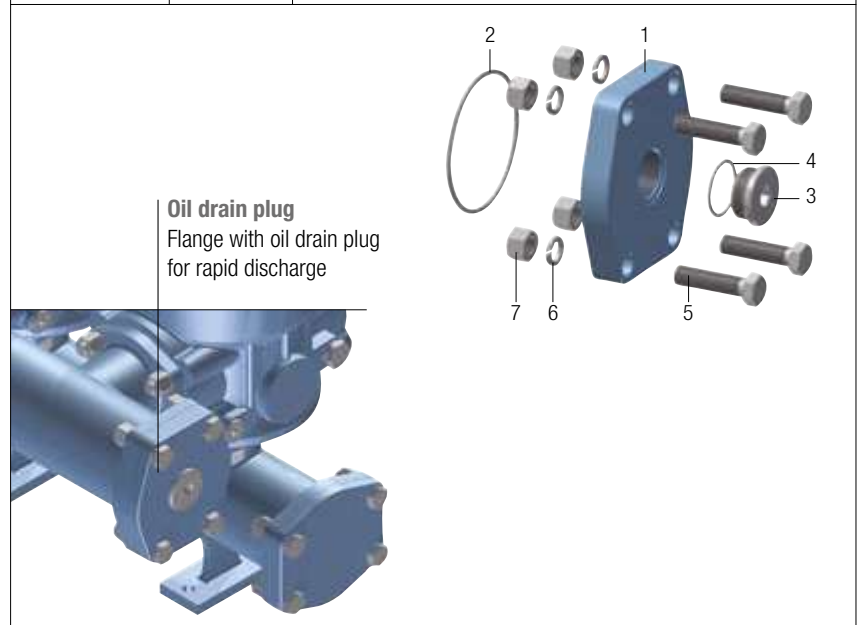

LMP 952-953-954

Designation & Ordering code

COMPLETE FILTER

Series and size **LMP952 | LMP953 | LMP954** Configuration example: **LMP952** **3** **B** **A** **FA** **A10** **N** **P01**

Length **3**

Bypass valve **S** Without bypass **B** With bypass 3.5 bar

Seals and treatments **A** NBR **V** FPM

Connections **FA** 4" SAE 3000 psi

Filtration rating (filter media)

A03 Inorganic microfiber 3 µm	M25 Wire mesh 25 µm
A06 Inorganic microfiber 6 µm	M60 Wire mesh 60 µm
A10 Inorganic microfiber 10 µm	M90 Wire mesh 90 µm
A16 Inorganic microfiber 16 µm	
A25 Inorganic microfiber 25 µm	

WA025 Water absorber inorganic microfiber 25 µm

Element Δp **N** 20 bar

Execution **P01** MP Filtri standard
P02 With internal tube for low flow rate
Pxx Customized

FILTER ELEMENT

Element series and size **CU950** Configuration example: **CU950** **3** **A10** **A** **N** **P01**

Element length **3**

Filter series and size

LMP952 Nr. 2 filter elements
LMP953 Nr. 3 filter elements
LMP954 Nr. 4 filter elements

Filtration rating (filter media)

A03 Inorganic microfiber 3 µm	M25 Wire mesh 25 µm
A06 Inorganic microfiber 6 µm	M60 Wire mesh 60 µm
A10 Inorganic microfiber 10 µm	M90 Wire mesh 90 µm
A16 Inorganic microfiber 16 µm	
A25 Inorganic microfiber 25 µm	

WA025 Water absorber inorganic microfiber 25 µm

Seals **A** NBR **V** FPM

Element Δp **N** 20 bar

Execution **P01** MP Filtri standard
Pxx Customized

CLOGGING INDICATORS

See page 720

DEA Electrical differential pressure indicator	DLE Electrical / visual differential pressure indicator
DEM Electrical differential pressure indicator	DTA Electronic differential pressure indicator
DEU Electrical differential pressure indicator	DVA Visual differential pressure indicator
DLA Electrical / visual differential pressure indicator	DVM Visual differential pressure indicator

PLUGS

See page 741

T2 Plug

LMP 952-953-954

Dimensions

LMP952

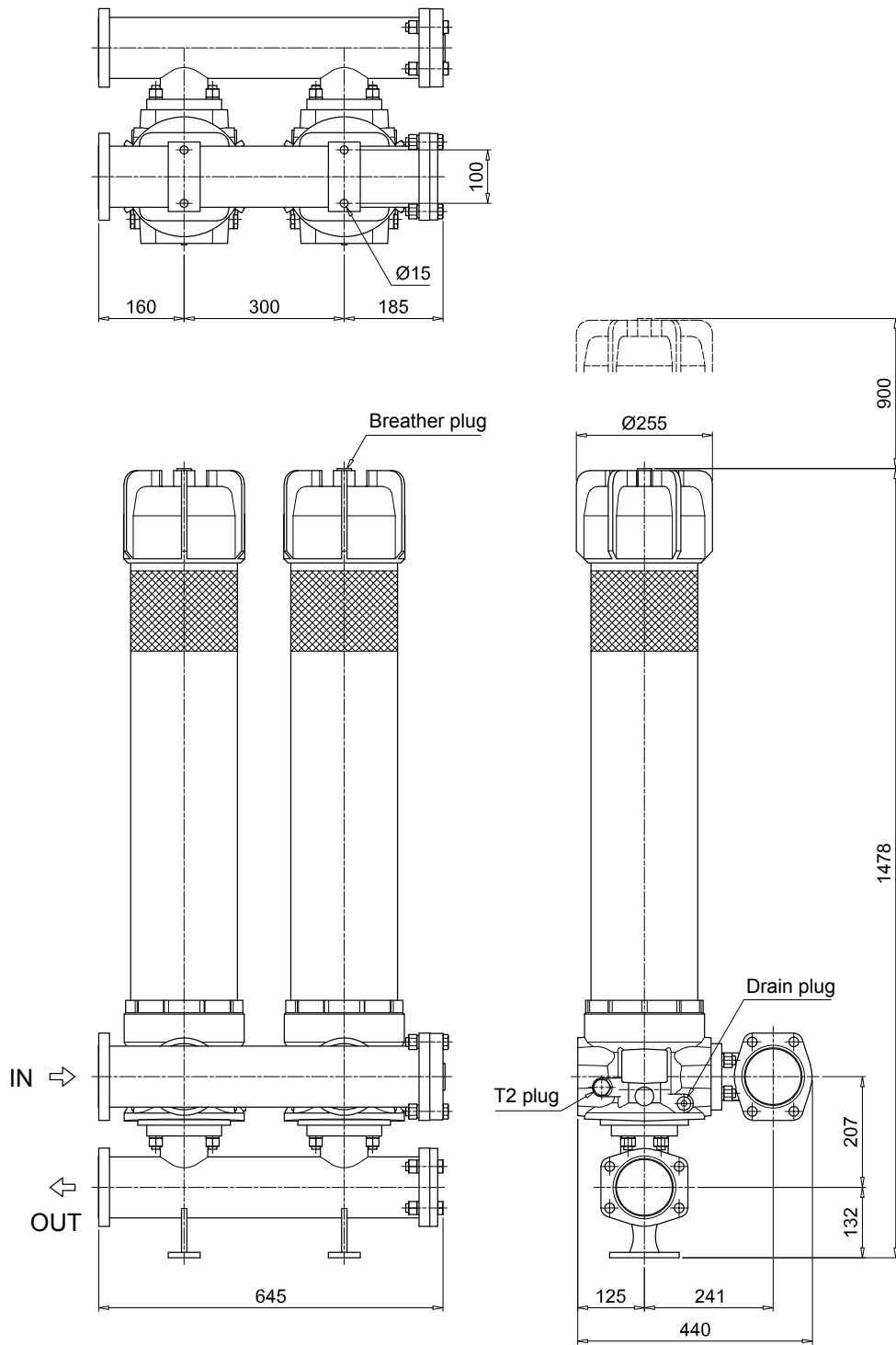

T2 plug = connection for differential pressure indicator

LMP 952-953-954

Dimensions

LMP953

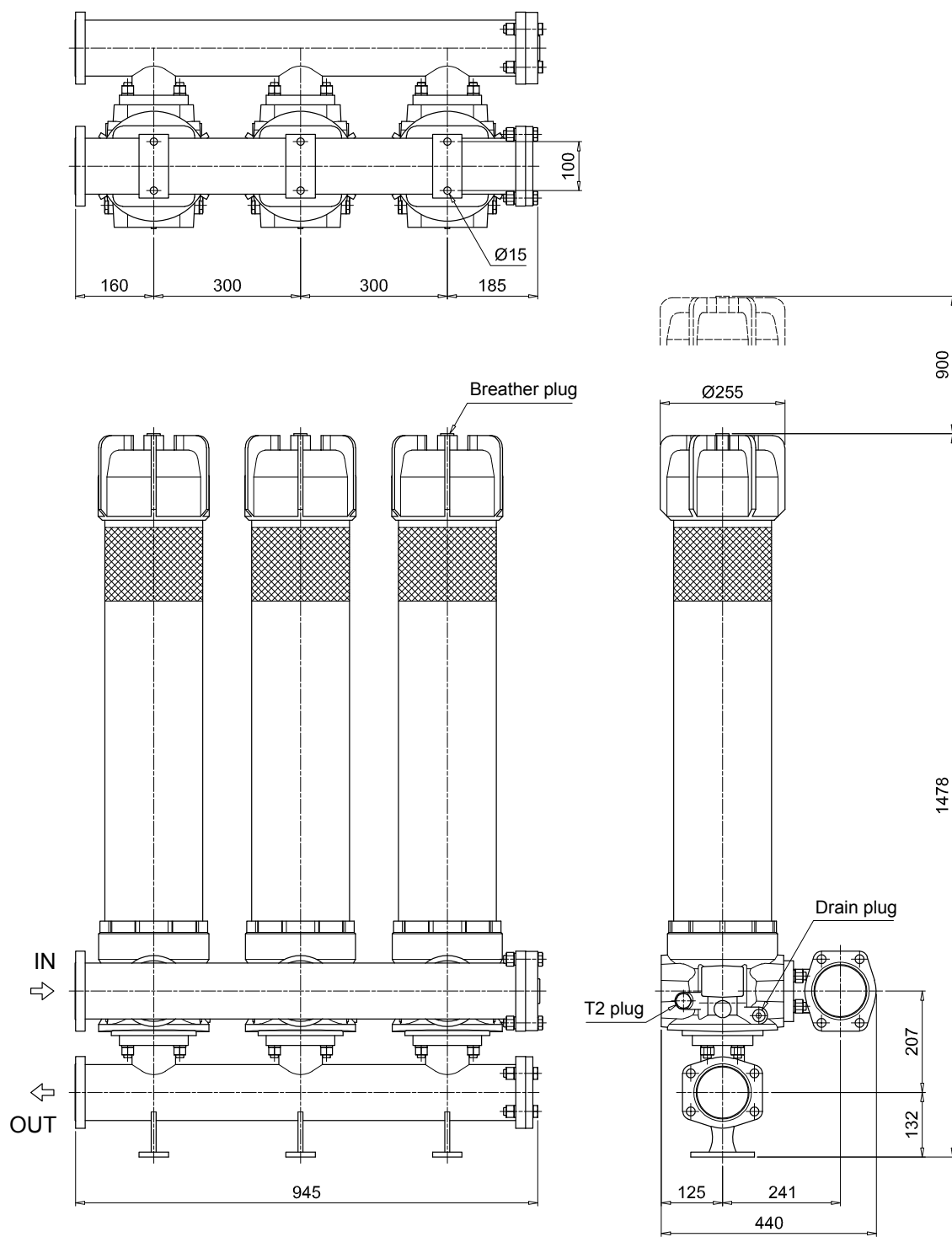

T2 plug = connection for differential pressure indicator

LMP 952-953-954

Dimensions

LMP954

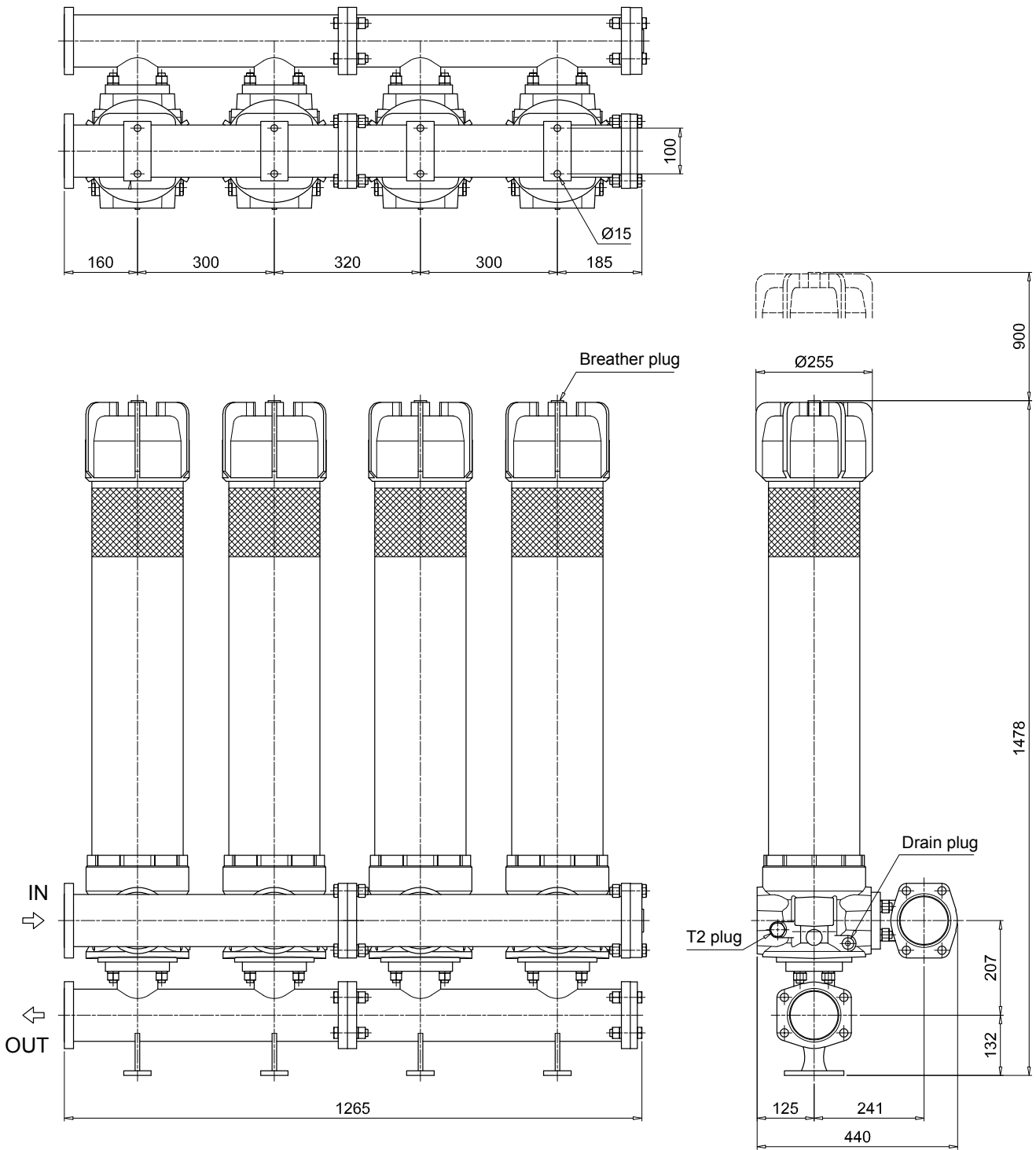

T2 plug = connection for differential pressure indicator

LMP 952-953-954 SPARE PARTS

Order number for spare parts

LMP 952 - 953 - 954

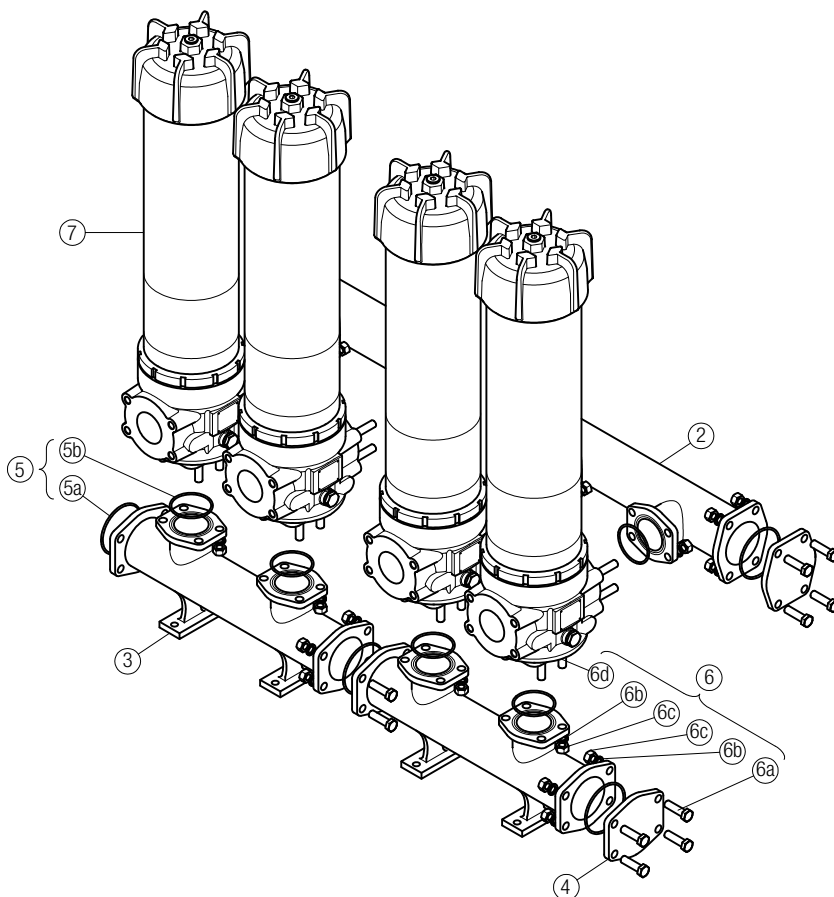

Item 7:
for complete filter code and
spare parts, see
LMP 950 - 951 series chapter

Quantity:
- filter spare parts:
LMP 952 - 2 pcs.
LMP 953 - 3 pcs.
LMP 954 - 4 pcs.

- filter seal kit:
LMP 952 - 2 pcs.
LMP 953 - 3 pcs.
LMP 954 - 4 pcs.

Item:	2		3		4		5 (5a-5b)		6 (6a ÷ 6d)		7	
Filter series	Q.ty	Manifold IN	OUT	4" SAE 3000 psi plugged flange Q.ty	Q.ty	Manifolds seal kit		Threaded fasteners kit		Q.ty	Filter	
						NBR	FPM					
LMP 952	1 pc.	01039270	01039271	2 pcs.	01042012	1 pc.	02050404	02050405	1 pc.	02049051	2 pcs.	LMP9513xxF1xxxNP0x
LMP 953	1 pc.	01039337	01039338	2 pcs.		1 pc.	02050404	02050405	1 pc.	02049052	3 pcs.	
LMP 954	2 pcs.	01039270	01039271	2 pcs.		1 pc.	02050406	02050407	1 pc.	02049053	4 pcs.	

LubeTeam Hydraulic S.r.l.

Administration and Headquarter:

Via Tufara Scautieri, 6

83018 - San Martino Valle Caudina (AV)

Office and Warehouse:

S.S. 7 Appia, Km. 237,00

82011 - Airola BN

ITALY

Tel. +39 0823 950 994

Fax +39 0823 412 546

www.lubeteam.it info@lubeteam.it

Italian VAT / C.F. e P.IVA: 01251720627

Follow us



This document is the property of LubeTeam Hydraulic S.r.l. All data reported here are for the exclusive use of the Receiver. Reproduction is not authorized without writing permission, in all or in part of the content of this document, in accordance to Law 633 art. 171, dated April 22, 1941.

Il presente documento è di proprietà della LubeTeam Hydraulic S.r.l. I dati riportati sono per esclusivo del destinatario. La riproduzione, di tutto o in parte, non è autorizzata senza permesso scritto secondo l'art. 171 della L. 633 del 22 Aprile 1941.