



Kit di Monitoraggio  
Prearica FOX Serie KIT-  
M - KIT-T - KIT-P



 HYDRAULIC  
COMPONENTS  
& FLUID CONTAMINATION  
CONTROL



All trademarks belong to their respective owners; third party trademarks, product names, trade names, corporate names and company names mentioned may be trademarks of their respective owners or registered trademarks of other companies and are used for instructional purposes and for the benefit of the owner, without any end of Copyright infringement in force.

Tutti i marchi riportati appartengono ai legittimi proprietari; marchi di terzi, nomi di prodotti, nomi commerciali, nomi corporativi e società citati possono essere di proprietà dei rispettivi titolari o registrati da altre società e sono stati utilizzati a puro scopo esplicativo e a beneficio del possessore, senza alcun fine di violazione dei diritti di Copyright vigenti.

## VG - VALVOLE DI SICUREZZA / PRESSURE SAFETY VALVE

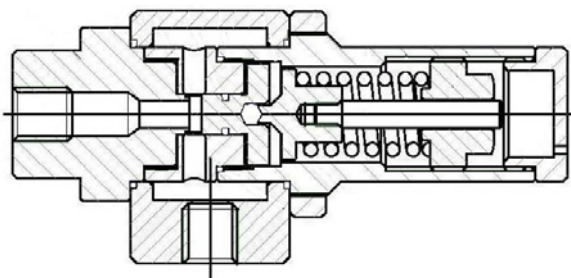

Caratteristiche tecniche:	Technical features:
<ul style="list-style-type: none"> <li>- Utili per salvaguardare l'integrità dell'accumulatore in caso di sovrappressione; in caso di sovrappressione scaricano l'azoto contenuto nell'accumulatore proteggendo il corpo dallo scoppio</li> <li>- Materiale corpo: A105</li> <li>- Connessione standard: 3/4" BSP-F</li> <li>- Pressione di taratura: secondo richiesta</li> <li>- Temperatura operativa: -20 / +150°C</li> <li>- Accuratezza: ±7%</li> <li>- Conforme a CE/PED</li> <li>- Disponibile con attacchi da 1/2" e 1"</li> <li>- Disponibile in AISI 316</li> </ul>	<ul style="list-style-type: none"> <li>- Useful for safeguarding the integrity of the accumulator in case of overpressure; in case of overpressure, that valve unload the nitrogen contained into the accumulator, protecting the body from bursting</li> <li>- Body Material: A105</li> <li>- Standard connection: 3/4" BSP-F</li> <li>- Setting pressure: as request</li> <li>- Operating temperature: -20 / +150°C</li> <li>- Accuracy: ±7%</li> <li>- According to CE/PE</li> <li>- Available connection 1/2" e 1"</li> <li>- Disponibile in AISI 316</li> </ul>

## DR - DISCO DI ROTTURA / RUPTURE BURST DISCK

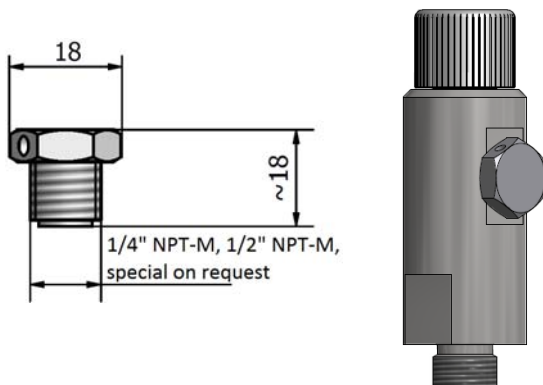

Caratteristiche tecniche:	Technical features:
<ul style="list-style-type: none"> <li>- Utili per salvaguardare l'integrità dell'accumulatore in caso di sovrappressione o sovratemperatura; in caso di sovrappressione o sovratemperatura scaricano l'azoto contenuto nell'accumulatore proteggendo il corpo dallo scoppio</li> <li>- Materiale corpo: ASTM A240 316L</li> <li>- Materiale disco: ASTM A240 316L</li> <li>- Materiale guarnizione: ASTM A240 316L</li> <li>- Connessione idraulica: come da disegno</li> <li>- Scarico radiale o frontale</li> <li>- Pressione di rottura: secondo richiesta</li> <li>- Temperatura di rottura: secondo richiesta</li> <li>- Accuratezza: ±10%</li> <li>- Conforme a CE/PED</li> </ul>	<ul style="list-style-type: none"> <li>- Useful for safeguarding the integrity of the accumulator in case of overpressure or overtemperature; in case of overpressure or overtemperature, that valve unload the nitrogen contained into the accumulator, protecting the body from bursting</li> <li>- Body material: ASTM A240 316L</li> <li>- Disc material: ASTM A240 316L</li> <li>- Seal material: ASTM A240 316L</li> <li>- Hydraulic connection: as per drawing</li> <li>- Radial or frontal discharge</li> <li>- Rupture pressure: as per request</li> <li>- Rupture temperature: as per request</li> <li>- Accuracy: ±10%</li> <li>- According to CE/PED</li> </ul>

## TFC - TAPPI DI FUSIONE PER SCARICO GAS / TEMPERATURE FUSE CAP FOR GAS UNLOAD

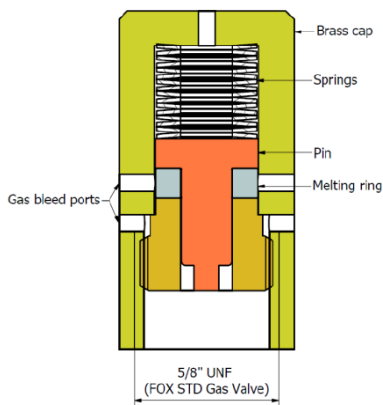

Caratteristiche tecniche:	Technical features:
<ul style="list-style-type: none"> <li>- Utili per salvaguardare l'integrità dell'accumulatore in caso di incendio o sovratemperatura; in caso di incendio, all'interno si scioglie una pastiglia termica, successivamente la molla di spinta preme sul pin di tenuta valvola scaricando l'azoto contenuto nell'accumulatore proteggendo il corpo dallo scoppio</li> <li>- Materiale corpo: A350LF2 o SS 316</li> <li>- Scarico perpendicolare</li> <li>- Temperatura di fusione: 135°C</li> <li>- Temperatura operativa: -40 / +100°C</li> <li>- Accuratezza: ±5°C</li> </ul>	<ul style="list-style-type: none"> <li>- Useful for safeguarding the integrity of the accumulator in case of fire or overtemperature; in case of fire, inside the cap, a thermal pad melts, then the thrust spring presses on the valve pin of the valve that unload the nitrogen contained into the accumulator, protecting the body from bursting</li> <li>- Body material: A350LF2 o SS 316</li> <li>- Perpendicular discharge</li> <li>- Fuse temperature: 135°C</li> <li>- Operating temperature: -40 / +100°C</li> <li>- Accuracy: ±5°C</li> </ul>

## KIT MONITORAGGIO PRECARICA / MONITORING PRECHARGE KIT



**KIT-M**  
Kit con manometro  
Kit with pressure gauge

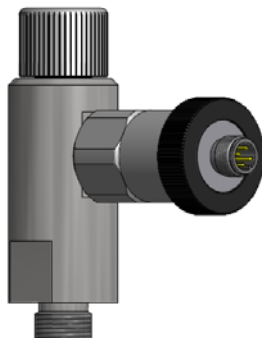

**KIT-T**  
Kit con trasduttore di pressione  
Kit with pressure transducer

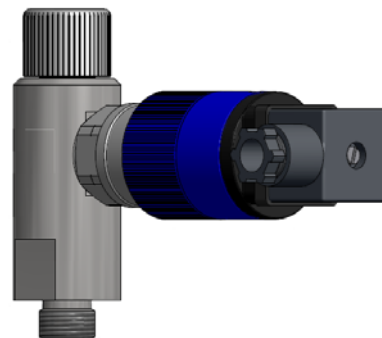

**KIT-P**  
Kit con pressostato  
Kit with pressure switch

Sono disponibili combinazioni speciali o con doppio controllo (combinando i vari controlli, es. manometro + trasduttore o trasduttore + disco di rottura, ecc...)  
Are also available special execution or with double control (combined some control, example pressure gauge + transducer or transducer + rupture disc, ecc...)



## LubeTeam Hydraulic S.r.l.

*Administration and Headquarter:*

Via Tufara Scautieri, 6

83018 - San Martino Valle Caudina (AV)

*Office and Warehouse:*

S.S. 7 Appia, Km. 237,00

82011 - Airola BN

ITALY

Tel. +39 0823 950 994

Fax +39 0823 412 546

[www.lubeteam.it](http://www.lubeteam.it) [info@lubeteam.it](mailto:info@lubeteam.it)

Italian VAT / C.F. e P.IVA: 01251720627

Follow us



This document is the property of LubeTeam Hydraulic S.r.l. All data reported here are for the exclusive use of the Receiver. Reproduction is not authorized without writing permission, in all or in part of the content of this document, in accordance to Law 633 art. 171, dated April 22, 1941.

Il presente documento è di proprietà della LubeTeam Hydraulic S.r.l. I dati riportati sono per esclusivo del destinatario. La riproduzione, di tutto o in parte, non è autorizzata senza permesso scritto secondo l'art. 171 della L. 633 del 22 Aprile 1941.